

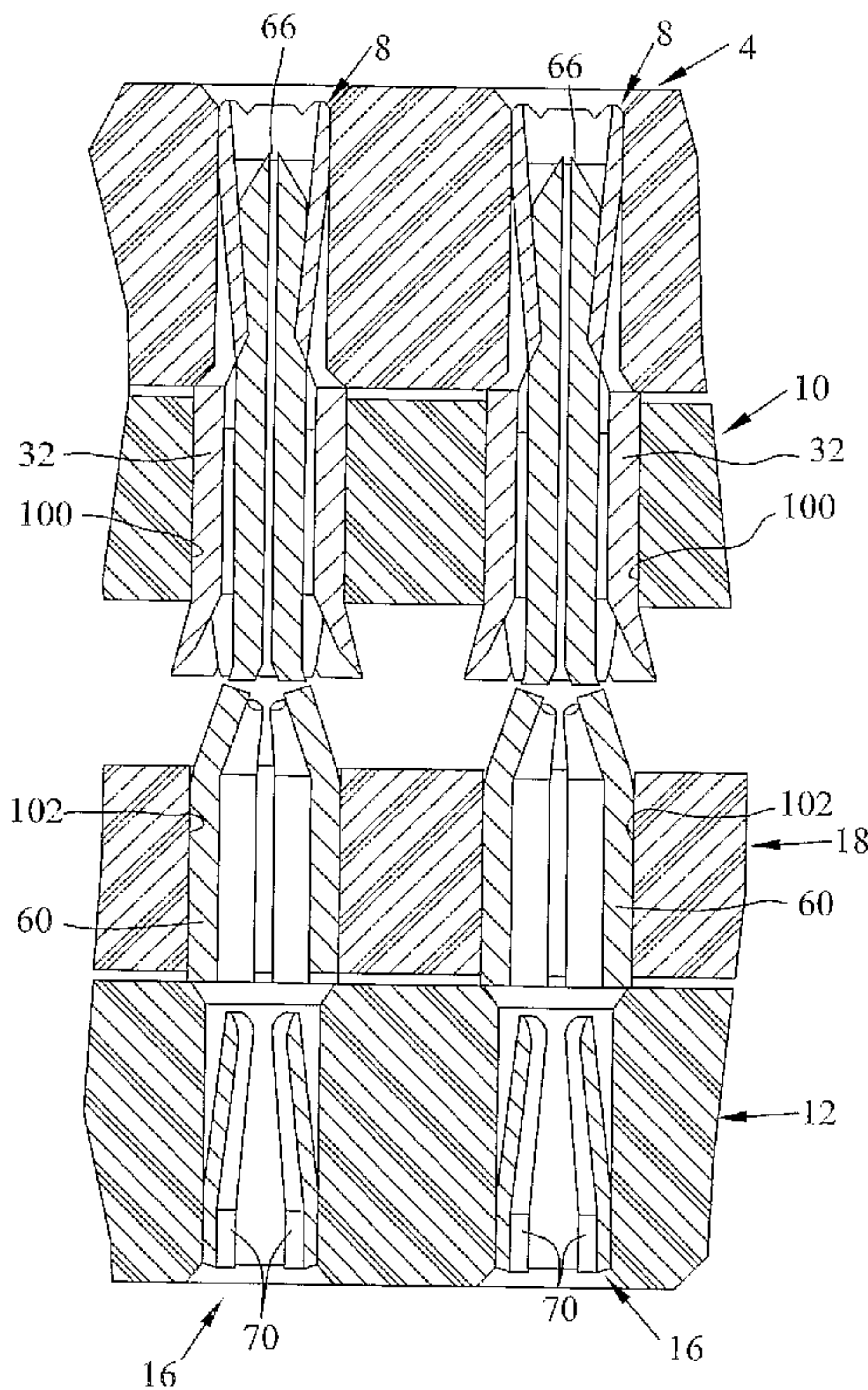

(86) Date de dépôt PCT/PCT Filing Date: 2006/11/06
 (87) Date publication PCT/PCT Publication Date: 2007/05/18
 (85) Entrée phase nationale/National Entry: 2008/04/22
 (86) N° demande PCT/PCT Application No.: US 2006/043204
 (87) N° publication PCT/PCT Publication No.: 2007/056291
 (30) Priorité/Priority: 2005/11/09 (US11/270,171)

(51) Cl.Int./Int.Cl. *H01R 12/04* (2006.01)
 (71) Demandeur/Applicant:
 TYCO ELECTRONICS CORPORATION, US
 (72) Inventeurs/Inventors:
 BREKOSKY, LAWRENCE JOHN, US;
 MILLER, KEITH EDWIN, US
 (74) Agent: SMART & BIGGAR

(54) Titre : **CONNECTEUR D'EMPILEMENT DE CARTES DE CIRCUIT IMPRIME A INTERFACE SEPARABLE**
 (54) Title: **PRINTED CIRCUIT BOARD STACKING CONNECTOR WITH SEPARABLE INTERFACE**



(57) **Abrégé/Abstract:**

A board to board interconnection is provided for interconnection of parallel stacked printed circuit boards, with a like array of plated through holes on each of the boards. One connector assembly is insertable from the outside of one of the stacked printed circuit

(57) **Abrégé(suite)/Abstract(continued):**

boards, and another electrical connector assembly is insertable from the opposite side of the stacked parallel boards. One of the connector assemblies includes a compliant portion connectible with a plated through hole and including a socket contact. The other connector includes terminals with compliant portions for interconnection with the other board, and includes a pin terminal extending from the compliant portion which is insertable through the printed circuit boards and into interconnection with the socket of the other electrical connector assembly.

(12) INTERNATIONAL APPLICATION PUBLISHED UNDER THE PATENT COOPERATION TREATY (PCT)

(19) World Intellectual Property Organization
International Bureau(43) International Publication Date
18 May 2007 (18.05.2007)

PCT

(10) International Publication Number
WO 2007/056291 A1(51) International Patent Classification:
H01R 12/04 (2006.01)

(21) International Application Number:

PCT/US2006/043204

(22) International Filing Date:

6 November 2006 (06.11.2006)

(25) Filing Language:

English

(26) Publication Language:

English

(30) Priority Data:

11/270,171 9 November 2005 (09.11.2005) US

(71) Applicant (for all designated States except US): **TYCO ELECTRONICS CORPORATION** [US/US]; 2901 FULLING MILL ROAD, Middletown, PA 17057 (US).

(72) Inventors; and

(75) Inventors/Applicants (for US only): **BREKOSKY, Lawrence, John** [US/US]; 147 FAIRWAY DRIVE, Dillsburg, PA 17019 (US). **MILLER, Keith, Edwin** [US/US]; 195 ROOT ROAD, Manheim, PA 17545 (US).(74) Agents: **WOLSTONCROFT, Helen, Odar et al.**; TYCO TECHNOLOGY RESOURCES, 4550 NEW LINDEN HILL ROAD, SUITE 140, Wilmington, DE 19808 (US).

(81) Designated States (unless otherwise indicated, for every kind of national protection available): AE, AG, AL, AM, AT, AU, AZ, BA, BB, BG, BR, BW, BY, BZ, CA, CH, CN, CO, CR, CU, CZ, DE, DK, DM, DZ, EC, EE, EG, ES, FI, GB, GD, GE, GH, GM, GT, HN, HR, HU, ID, IL, IN, IS, JP, KE, KG, KM, KN, KP, KR, KZ, LA, LC, LK, LR, LS, LT, LU, LV, LY, MA, MD, MG, MK, MN, MW, MX, MY, MZ, NA, NG, NI, NO, NZ, OM, PG, PH, PL, PT, RO, RS, RU, SC, SD, SE, SG, SK, SL, SM, SV, SY, TJ, TM, TN, TR, TT, TZ, UA, UG, US, UZ, VC, VN, ZA, ZM, ZW.

(84) Designated States (unless otherwise indicated, for every kind of regional protection available): ARIPO (BW, GH, GM, KE, LS, MW, MZ, NA, SD, SL, SZ, TZ, UG, ZM, ZW), Eurasian (AM, AZ, BY, KG, KZ, MD, RU, TJ, TM), European (AT, BE, BG, CH, CY, CZ, DE, DK, EE, ES, FI, FR, GB, GR, HU, IE, IS, IT, LT, LU, LV, MC, NL, PL, PT, RO, SE, SI, SK, TR), OAPI (BF, BJ, CF, CG, CI, CM, GA, GN, GQ, GW, ML, MR, NE, SN, TD, TG).

[Continued on next page]

(54) Title: PRINTED CIRCUIT BOARD STACKING CONNECTOR WITH SEPARABLE INTERFACE

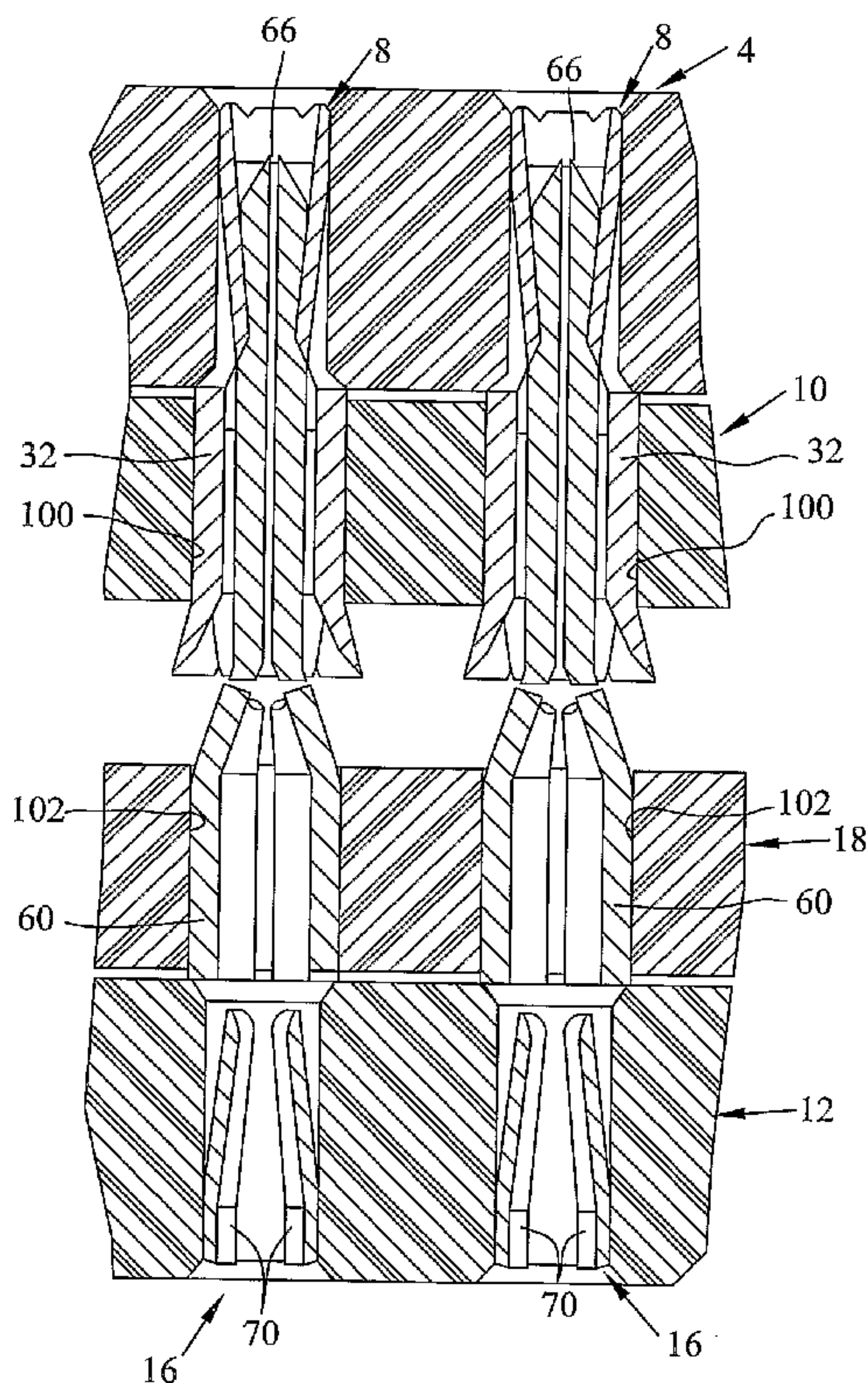

(57) Abstract: A board to board interconnection is provided for interconnection of parallel stacked printed circuit boards, with a like array of plated through holes on each of the boards. One connector assembly is insertable from the outside of one of the stacked printed circuit boards, and another electrical connector assembly is insertable from the opposite side of the stacked parallel boards. One of the connector assemblies includes a compliant portion connectible with a plated through hole and including a socket contact. The other connector includes terminals with compliant portions for interconnection with the other board, and includes a pin terminal extending from the compliant portion which is insertable through the printed circuit boards and into interconnection with the socket of the other electrical connector assembly.

WO 2007/056291 A1

WO 2007/056291 A1



Published:

— *with international search report*

For two-letter codes and other abbreviations, refer to the "Guidance Notes on Codes and Abbreviations" appearing at the beginning of each regular issue of the PCT Gazette.

**PRINTED CIRCUIT BOARD STACKING
CONNECTOR WITH SEPARABLE INTERFACE**

[0001] The present invention depicts electrical connectors for interconnection to printed circuit boards, and in particular for stacked board to board interconnections.

[0002] It is common to provide interconnections to and from printed circuit boards to other devices and or to other printed circuit boards. It is also common place to provide multi-layer printed circuit boards in specific applications. For example, it is common place to provide multi-layer stacked printed circuit boards in such instances as control technology where the boards are stacked one above the other in parallel manner in a closely spaced arrangement, with an insulator providing the insulative spacing between the two printed circuit boards. It is also common to provide printed circuit boards having a like array of plated through holes where the boards are interconnected at each plated through hole by a commoning connection at each of the plated through holes.

[0003] One such application has screw machined components having hexagonal, (or other multi-sided configuration) which are press-fit into one of the plated through holes and includes another pin or other interconnection device connected to the press-fit screw machined members. In such applications, the insertion forces for press fitting the screw machined components into the printed circuit board tend to be excessive and cause the screw machine contact and/or the printed circuit board to become damaged during the assembly.

[0004] These and other objects are to be accomplished with the following embodiments and teachings.

[0005] According to the present invention, a board to board interconnect assembly is obtained comprising a stamped and formed socket contact having a compliant portion for interconnection to a first printed circuit board plated throughhole and an integral socket portion. A stamped and formed pin contact has a compliant portion for interconnection to a

second printed circuit board plated throughhole, and a pin portion for interconnection to the integral socket portion.

[0006] A board to board interconnect assembly, comprises first and second printed circuit boards positioned in a spaced apart and parallel manner, each printed circuit board having an array of plated through holes, with the arrays in each board being in alignment. A stamped and formed socket contact has an integral socket portion and a compliant portion interconnected to the first printed circuit board plated throughhole. A stamped and formed pin contact has an integral pin portion and a compliant portion interconnected to a second printed circuit board plated throughhole. The pin portion projects through the first printed circuit board, and through the socket compliant portion, to interconnect the pin portion and socket portion.

[0007] Figure 1 is a side view of the components of the board to board interconnect of the invention shown in a space apart manner and poised for interconnection with each other;

[0008] Figure 2 shows an underside perspective view of the socket assembly of Figure 1;

[0009] Figure 3 shows a perspective view similar to that of Figure 2, of the housing without the socket contacts;

[0010] Figure 4 is an enlarged view of the portion denoted in Figure 3;

[0011] Figure 5 is a cross-sectional view through lines 5-5 of Figure 4;

[0012] Figure 6 is a perspective view of the socket contact of the present invention;

[0013] Figure 7 is an enlarged view of the portion denoted in Figure 1;

[0014] Figure 8 is an underside perspective of the pin assembly shown in Figure 1;

[0015] Figure 9 is a perspective view of one of the pin contacts of Figure 8;

[0016] Figure 10 is an enlarged view of the portion denoted in Figure 1; and

[0017] Figure 11 is a cross-sectional view similar to that of Figure 1 showing the board to board inner connect in its fully mated condition.

[0018] With reference first to Figure 1, a board to board interconnect assembly is shown generally at 2 which includes a socket assembly 4, having a socket housing 6 and a plurality of socket terminals 8. The socket assembly 6 is shown poised for receipt and interconnection to, a printed circuit board 10. Assembly 2 further includes a pin assembly 12 including a pin housing 14 and a plurality of pin terminals 16. Pin assembly 12 is shown poised for receipt and interconnection to a printed circuit board 18.

[0019] With reference now to Figure 2, socket assembly 4 is shown in greater detail as including a plurality of columns and rows of socket terminals 8 defining an array of socket terminals. With reference to Figures 3 and 4, socket housing 6 is shown in greater detail where socket housing 6 is comprised an insulative plate member 20 having a plurality of openings at 22. As shown in Figure 4, openings 22 include a U-shaped portion at 24 and a flat sidewall portion 26. As shown in Figure 3-5, openings 22 extend between an internal face 28 and an external face 30.

[0020] With reference now to Figure 6, socket terminals 8 are shown including compliant portions 32 integrally connected to socket portions 34 by way of an integral strap 36. As shown, compliant portions 32 include a C-shaped cross section around a body portion 38 which necks down into lead in portions 40 as described herein. As also shown in Figure 6, body portion 38 of compliant portion 32 includes an upper engaging surface 42 as will be described herein. Socket portion 34 includes a C-shaped retaining portion 46 having socket beams 50 extending downwardly from the retaining portion 46. As shown socket beams are deflected inwardly to form a constricted portion between contact surfaces 52 of socket beams 50 and with a contact surface portion 54 of strap 36.

[0021] Thus socket terminals 8 may be positioned in openings 22 with retaining portions 46 being positioned in openings 22, and with the socket beams 50 depending

downwardly as shown in Figure 7. As also shown, body portion 38 is a larger diameter than opening 22 and thus engaging surface 42 abuts inner face 28 of socket housing 6.

[0022] With respect now to Figure 8, pin assembly 12 is shown with a plurality of pin terminals 16 positioned in a plurality of columns and rows defining an array of pin terminals 16. It should be appreciated that the arrays of the pin terminals 16 and the array of socket terminals 8 are substantially identical in order to provide mating engagement between the two. It should also be appreciated that pin housing 14 is substantially identical to socket housing 6, and therefore pin housing 14 will not be described in detail herein.

[0023] With respect now to Figure 9, pin terminals 16 will now be described. Pin terminals 16 includes compliant portion 60 having a socket portion 62 integrally attached by way of strap portion 64. Furthermore pin portion 66 is integrally attached to compliant portion 60 from the opposite end as the socket portion 62. Socket portion 62 includes a C-shaped retaining portion 68 in the way of a compliant C-shaped member, having socket beams 70 extending downwardly therefrom. Socket portion 62 defines a three point contact by way of contact surfaces 72 of socket beams 70, and by way of contact surface portion 74 on strap portion 64. Furthermore, compliant portion 60 includes a body portion 80 of C-shaped configuration on the cross section together with a lead in portion at 82, and an engaging portion at 84.

[0024] Thus, as shown in Figure 10, pin terminals 16 are situated in pin housing 14 with the C-shaped retaining portions 68 maintaining the pin terminals 16 in openings 22 with the compliant portion 60 and the pin portion 66 exterior to pin housing 14, and with the engaging surface 84 in abutment with internal face 28. Thus, it is the socket assembly 4 in the configuration of Figure 7 and the pin assembly 12 in the configuration of Figure 10 which allow for the interconnection of the two assemblies 4, 12 and the two printed circuit boards 10 and 18 to be interconnected together. As shown in Figure 1, printed circuit board 10 includes a plurality of plated through holes 100 (only one of which is shown) however it should be appreciated that the through holes 100 have a like array as the array of socket terminals 8. Furthermore circuit board 18 is shown poised over pin assembly 12 where printed circuit board 18 has a plurality of plated through holes 102 (only one of

which is shown) for interconnection to pin assembly 12. Figure 1 also shows multiple spacers such as 104 positioned between the two circuit boards 10, 18. These spacers are intended to insulate the two boards 10, 18 and their components from each other. While shown as washers or grommets, it should be appreciated that this insulation could also be in the form of a sheet gasket, or any other spacer.

[0025] To make the interconnection, one of the boards 10 or 18 is positioned over its respective assembly 4 or 12. For example, and with respect again to Figure 1, printed circuit board 10 is positioned with the plurality of plated through holes 100 to be positioned over the compliant portions 32 which retains and electrically connects the socket terminals 8 to the plated through holes 100. During insertion into the PCB, the lead-in portions (40) of the socket contact flare open to allow for ease of mating to pin (66). Meanwhile printed circuit board 18 can be positioned with the plated through holes over pins 66 and in interconnection with compliant portions 60 which causes pins 66 to project out of plated through holes 102. As shown in Figure 11, the two assemblies may now be brought together, such that pins 66 protrude into openings 44 (Figure 7) of the socket terminals 8 and the pin portions 66 extends upwardly through compliant portion 32, to make contact with socket beams 50 and the kinked contact surface 54 (Figure 6).

[0026] Thus, a very inexpensive interconnect has been provided, for the placement of two printed circuit boards in a back to back manner for interconnecting the two boards together. It should also be appreciated from Figure 1, 10 or 11 that a further interconnection could be made with the socket beams 70 of pin terminal 16 for further electrical interconnection.

CLAIMS

1. A board to board interconnect assembly, comprising:
 - first and second printed circuit boards positioned in a spaced apart and parallel manner, each printed circuit board having an array of plated through holes, with said arrays in each board being in alignment;
 - a stamped and formed socket contact having an integral socket portion and a compliant portion interconnected to said first printed circuit board plated throughhole;
 - a stamped and formed pin contact having an integral pin portion and a compliant portion interconnected to a second printed circuit board plated throughhole; and
 - said pin portion projecting through said first printed circuit board, and through said socket compliant portion, to interconnect said pin portion and socket portion.
2. The board to board interconnect assembly of claim 1, further comprising a socket housing for housing the stamped and formed socket contact.
3. The board to board interconnect assembly of claim 2, further comprising a pin housing for housing the stamped and formed pin contact.
4. The board to board interconnect assembly of claim 3, wherein said integral socket portion is positioned in an opening of said socket housing, with said compliant portion of said socket contact being positioned on the exterior of said socket housing.
5. The board to board interconnect assembly of claim 4, wherein said stamped and formed pin contact further comprises a retaining portion for retaining said pin contact to said pin housing.
6. The board to board interconnect assembly of claim 5, wherein said pin portion extends from one end of said compliant portion and said retaining portion extends from an opposite end.

7. The board to board interconnect assembly of claim 6, wherein said retaining portion is positioned in an opening of said pin housing, with said compliant portion of said pin contact being positioned on the exterior of said housing, and the pin portion extending from said compliant portion.

8. The board to board interconnect assembly of claim 7, wherein said socket housing and socket contact are connectable to said first printed circuit board, with said socket contact compliant portion being positioned in the plated through hole of said first printed circuit board.

9. The board to board interconnect assembly of claim 8, wherein said pin housing and pin contact are connectable to said second printed circuit board, with said pin contact compliant portion being positioned in the plated through hole of said second printed circuit board, and with said pin projecting therefrom.

10. The board to board interconnect assembly of claim 9, wherein said stamped and formed pin contact further comprises a pin portion for interconnection to said integral socket portion and an integral socket portion for further electrical interconnection

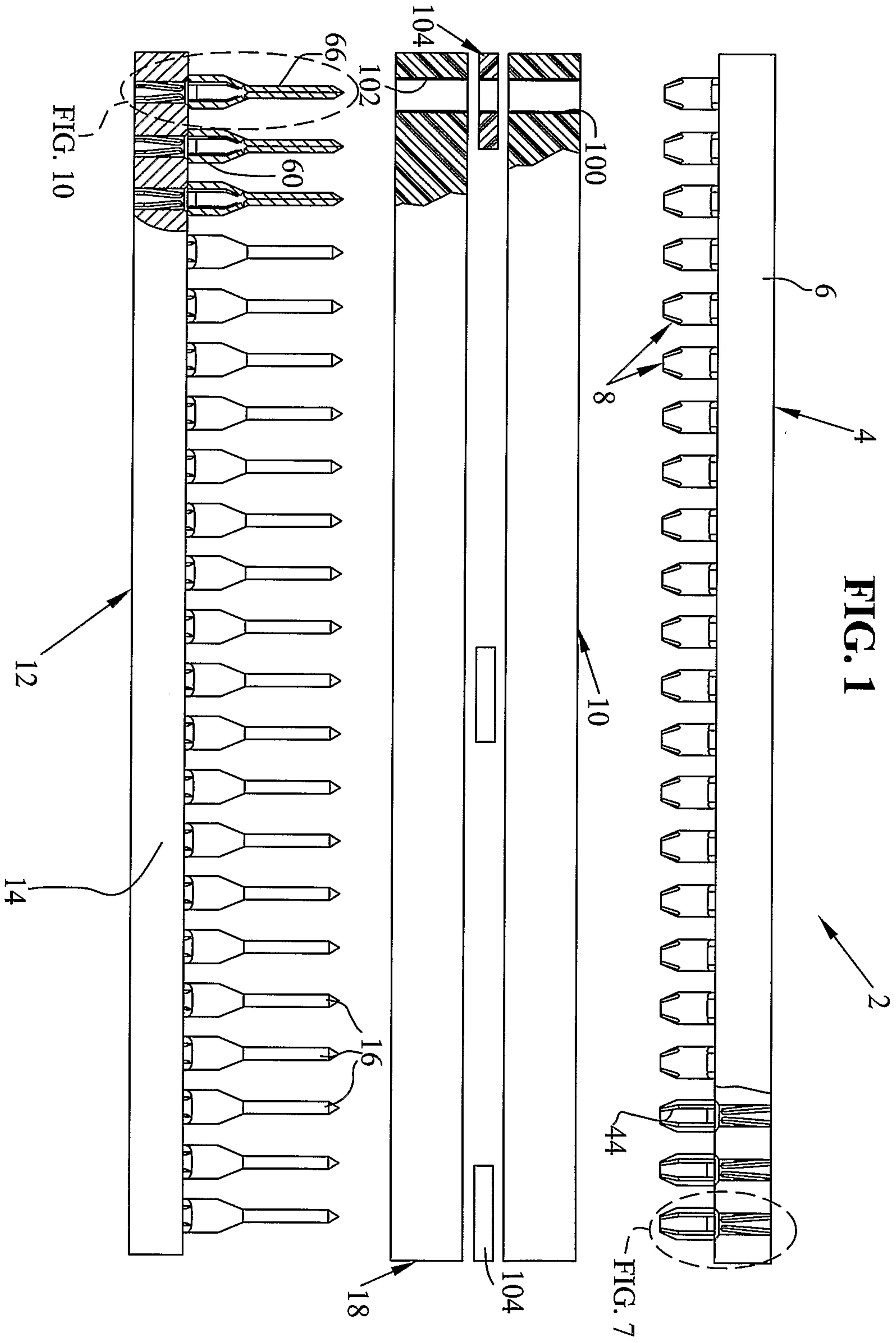

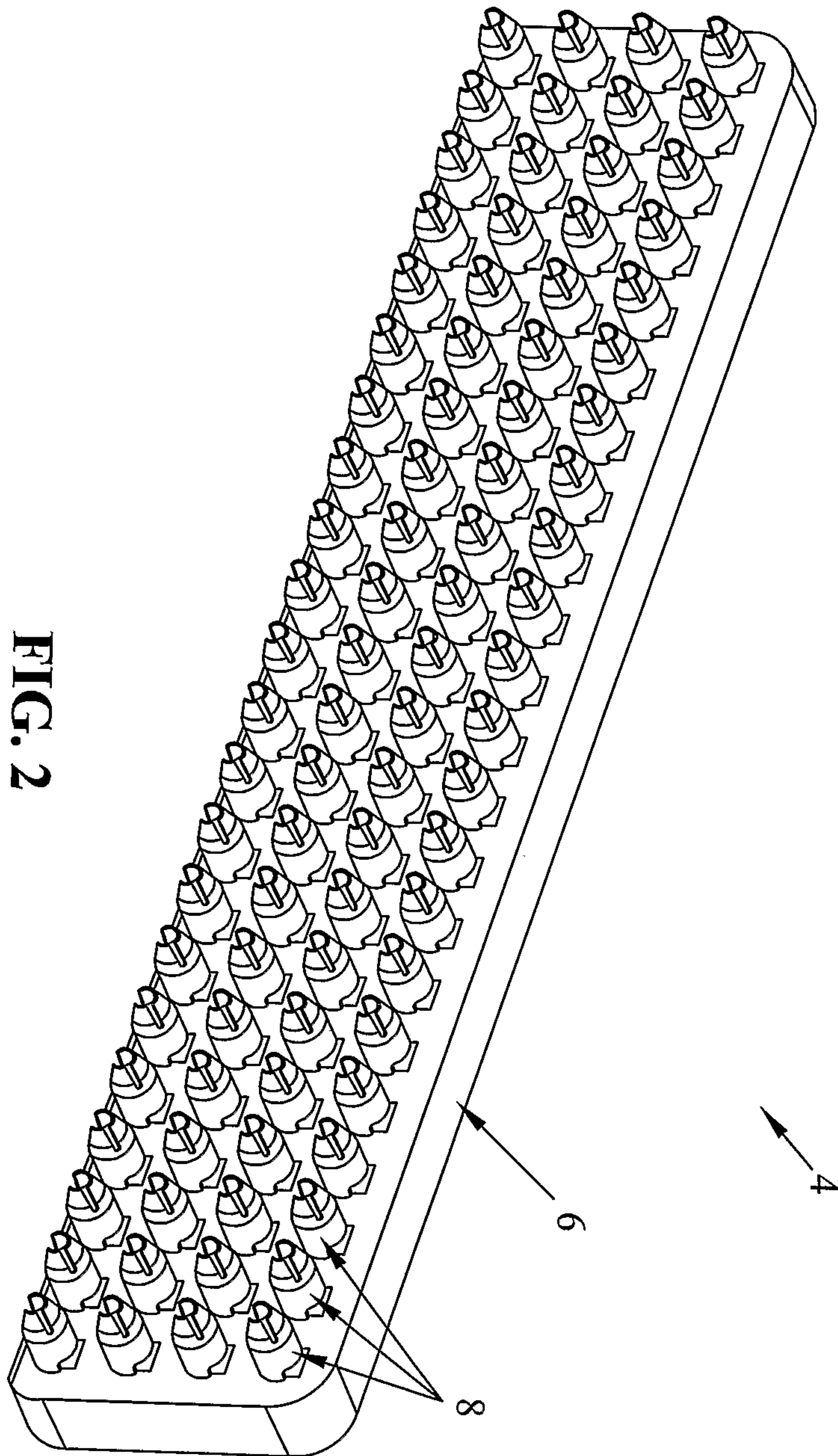

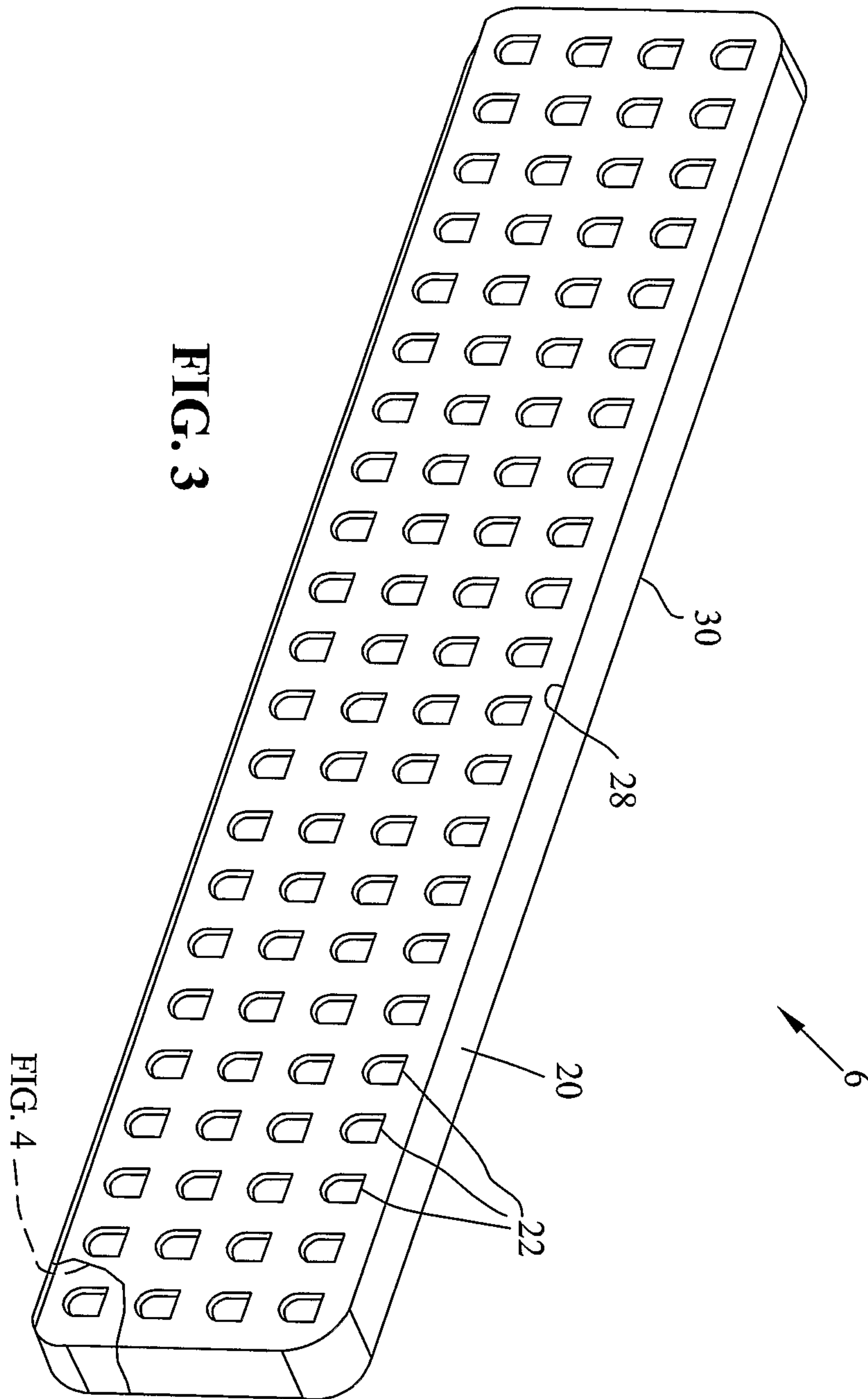

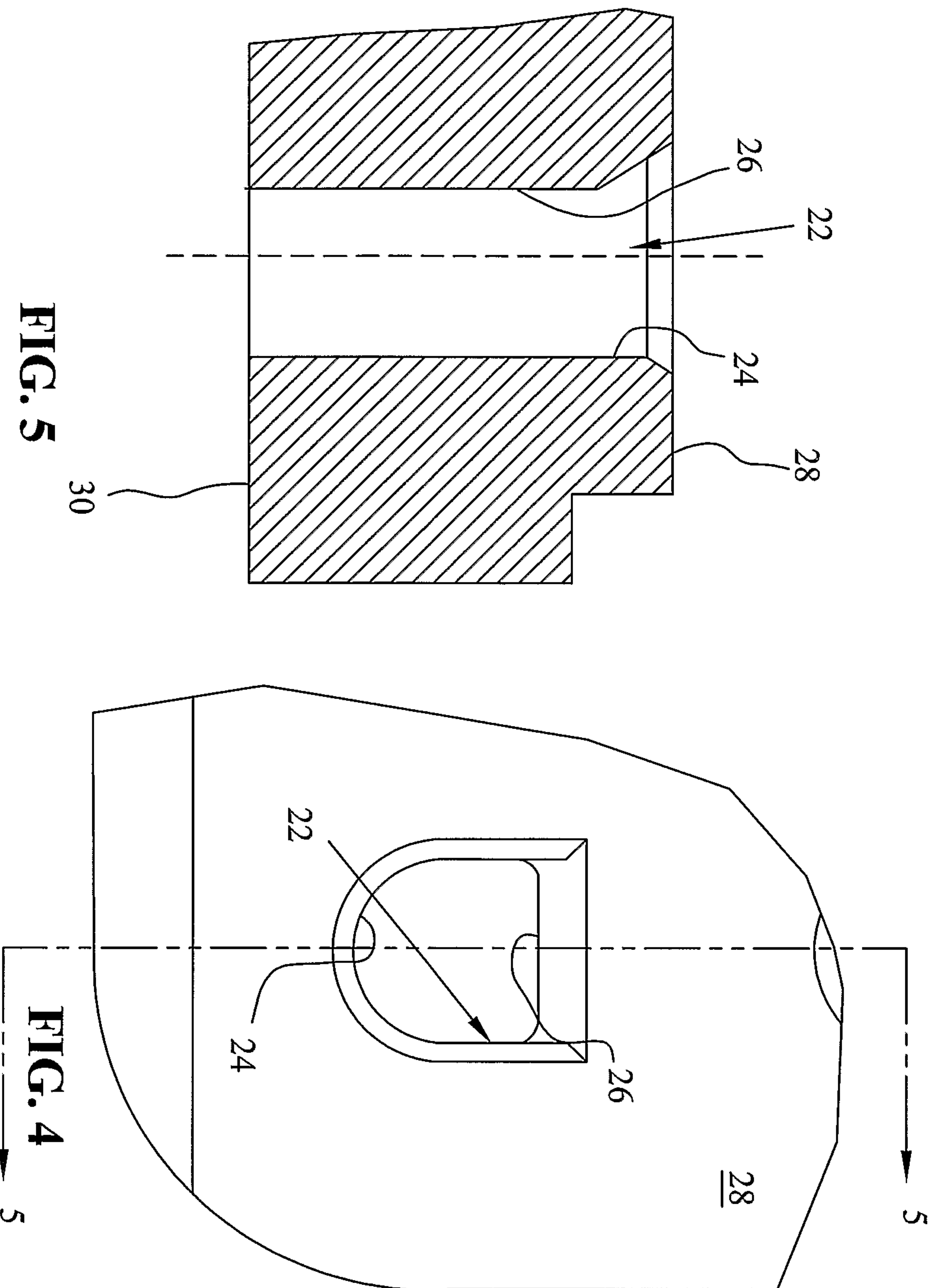

FIG. 5

FIG. 4

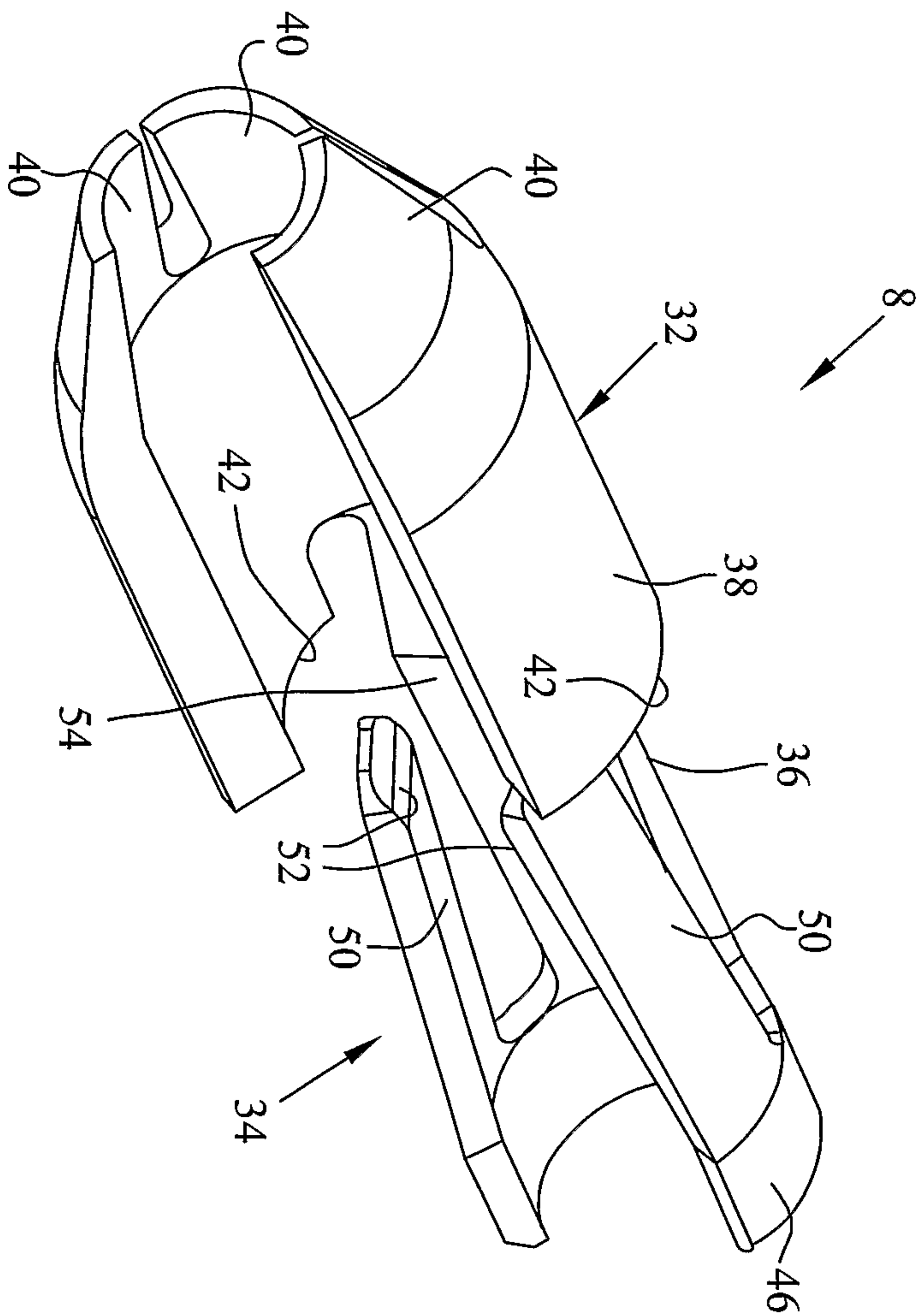

FIG. 6

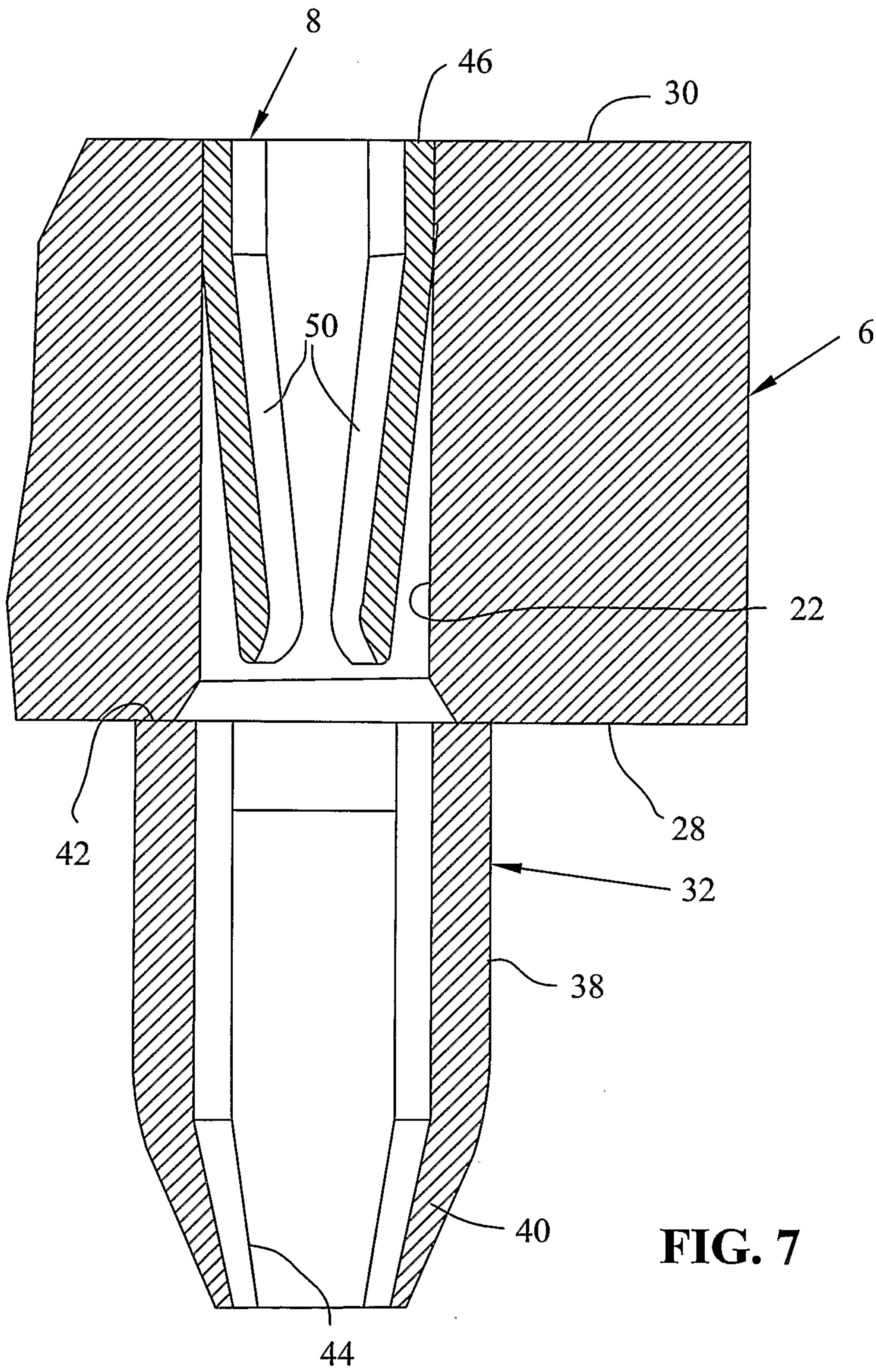

FIG. 7

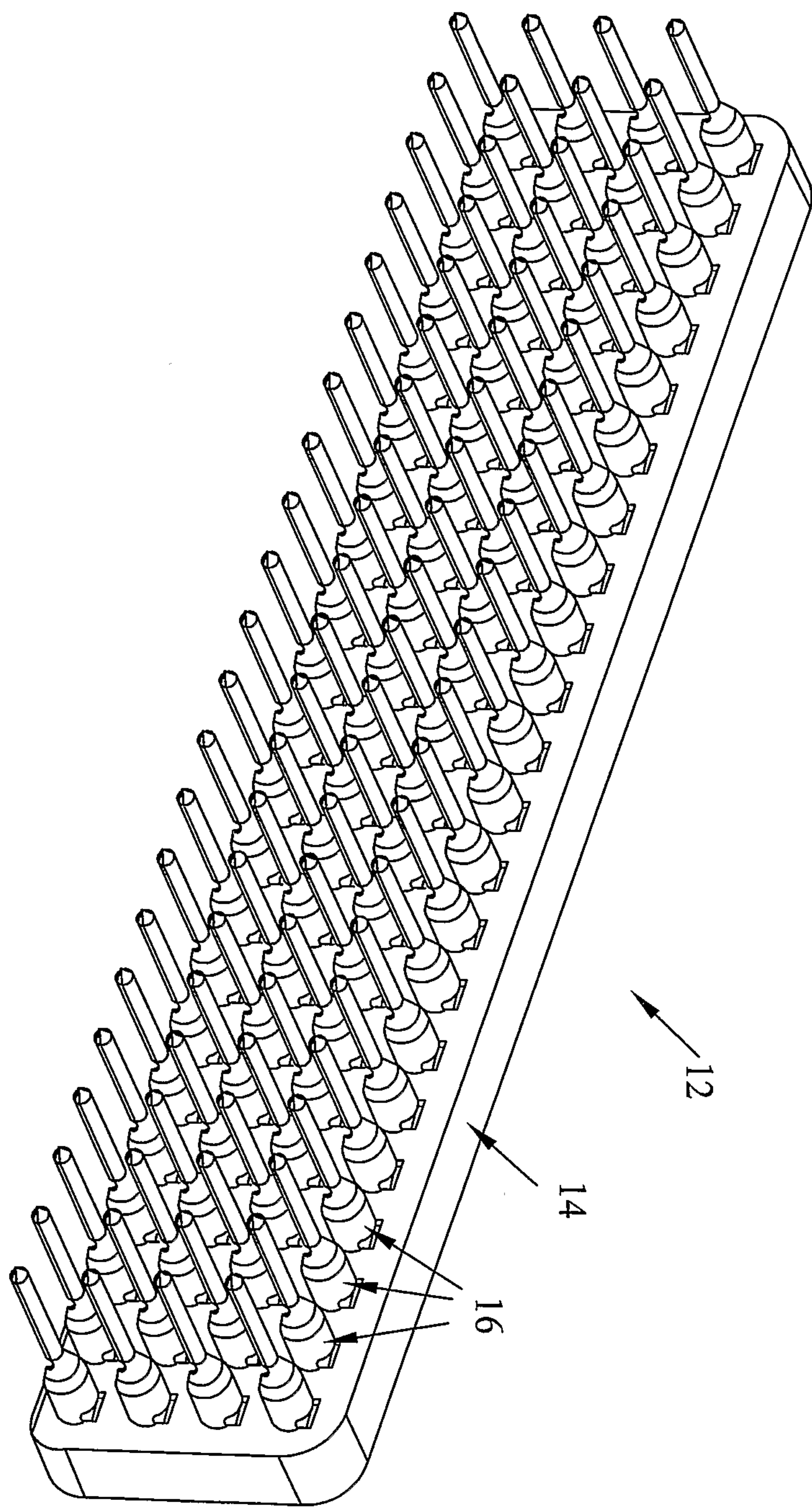

FIG. 8

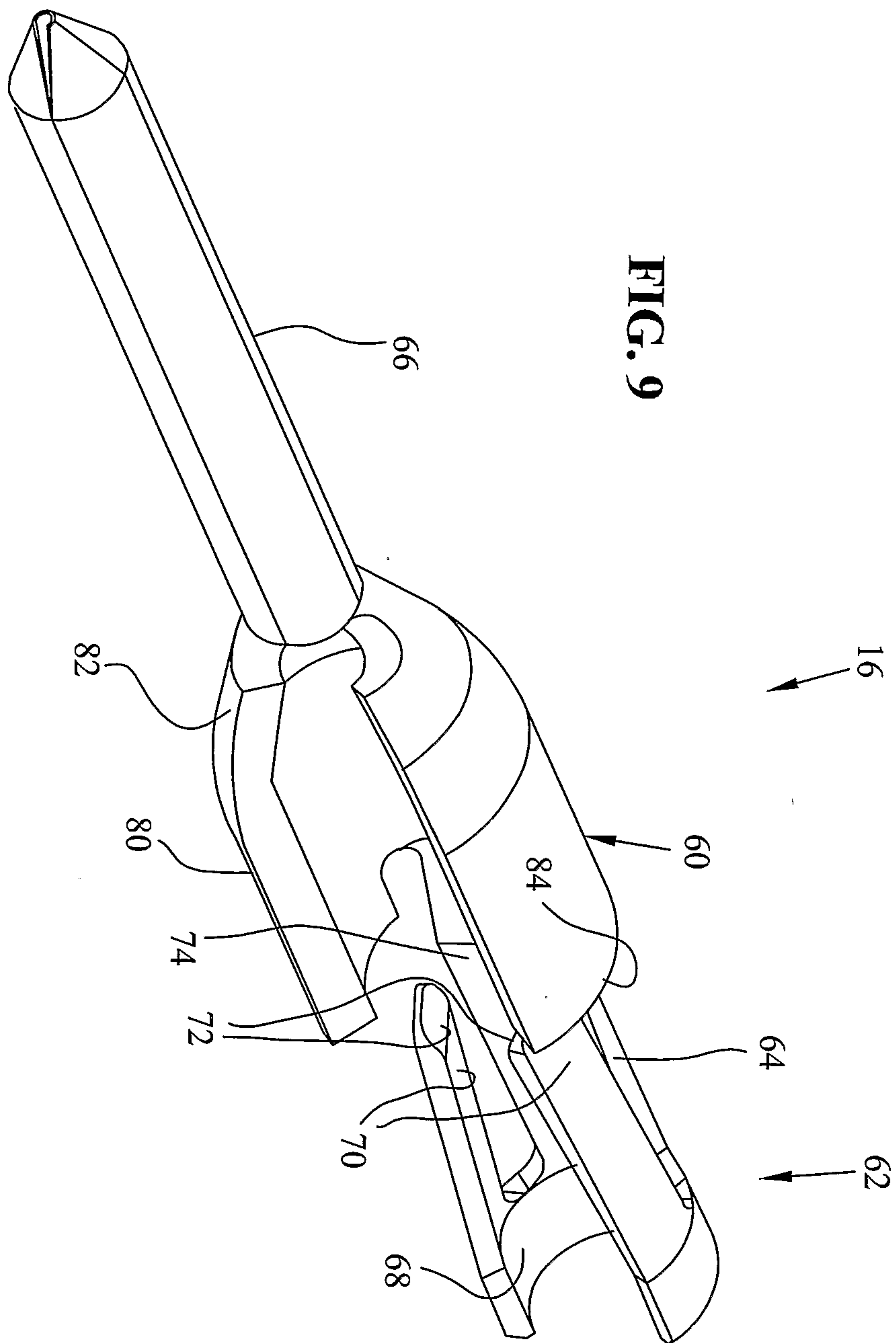
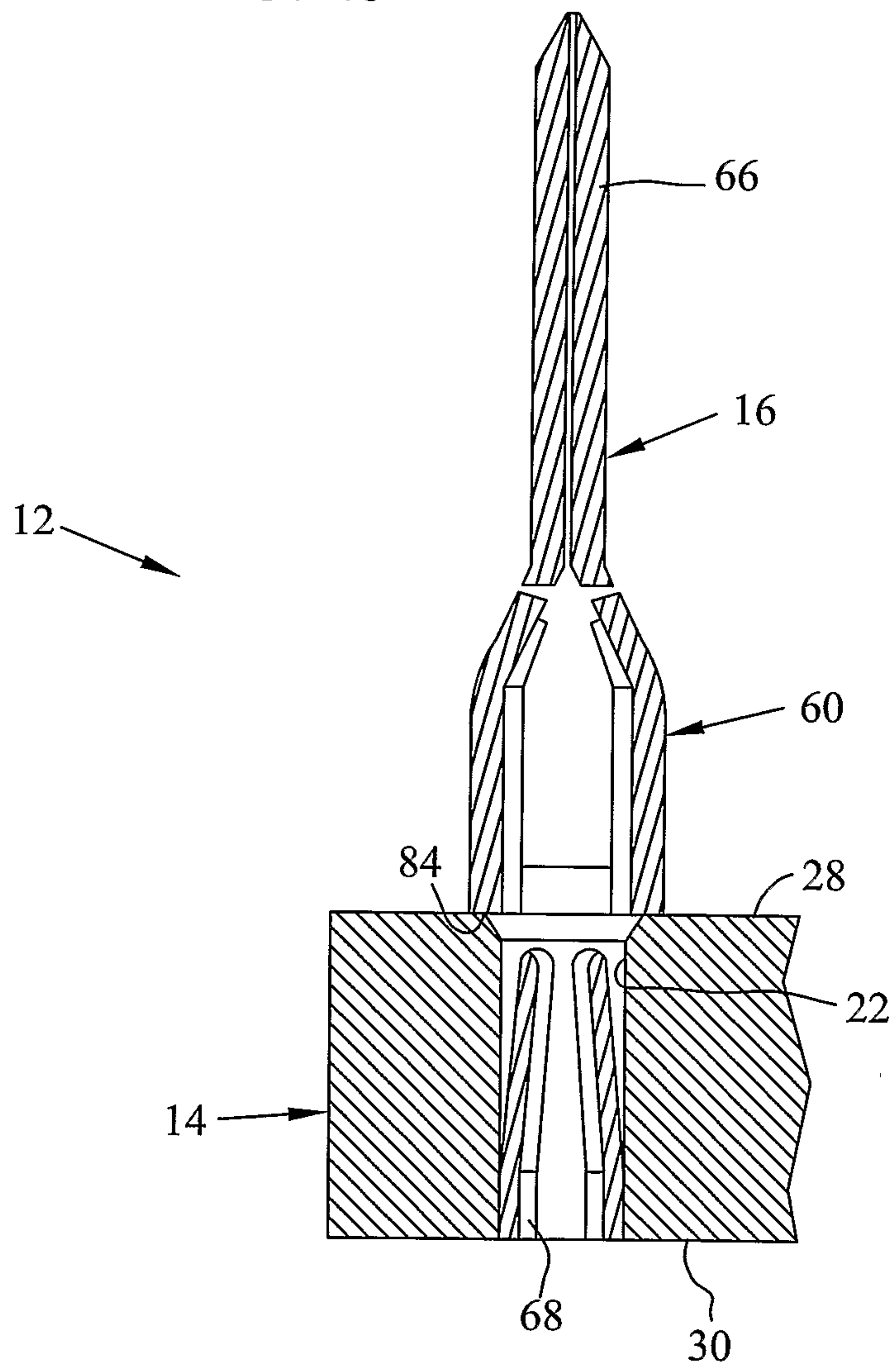

FIG. 10



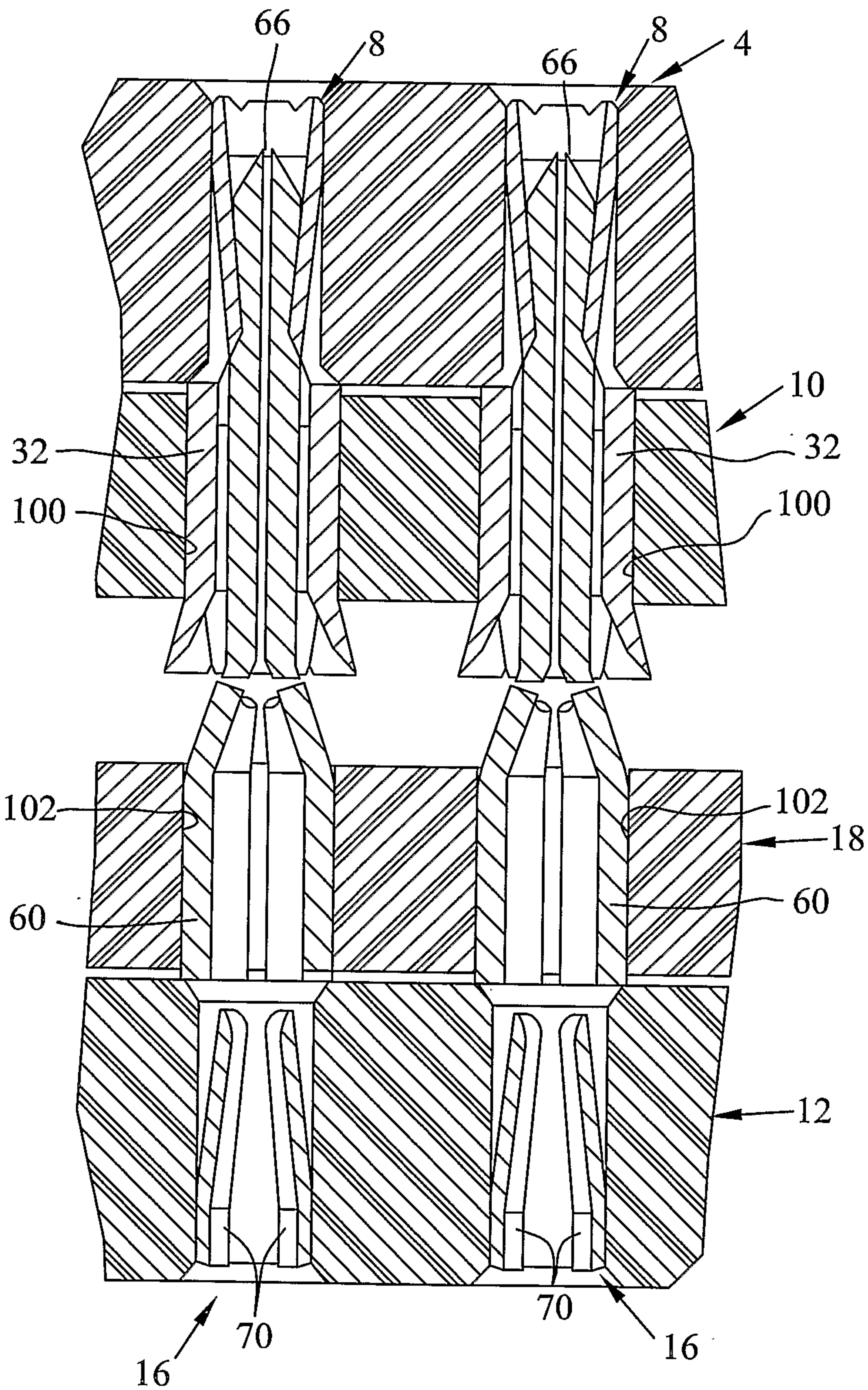

FIG. 11

