

May 21, 1940.

E. F. BRITTEN, JR  
CALCULATING MACHINE

2,201,713

Filed Sept. 30, 1939

3 Sheets-Sheet 1

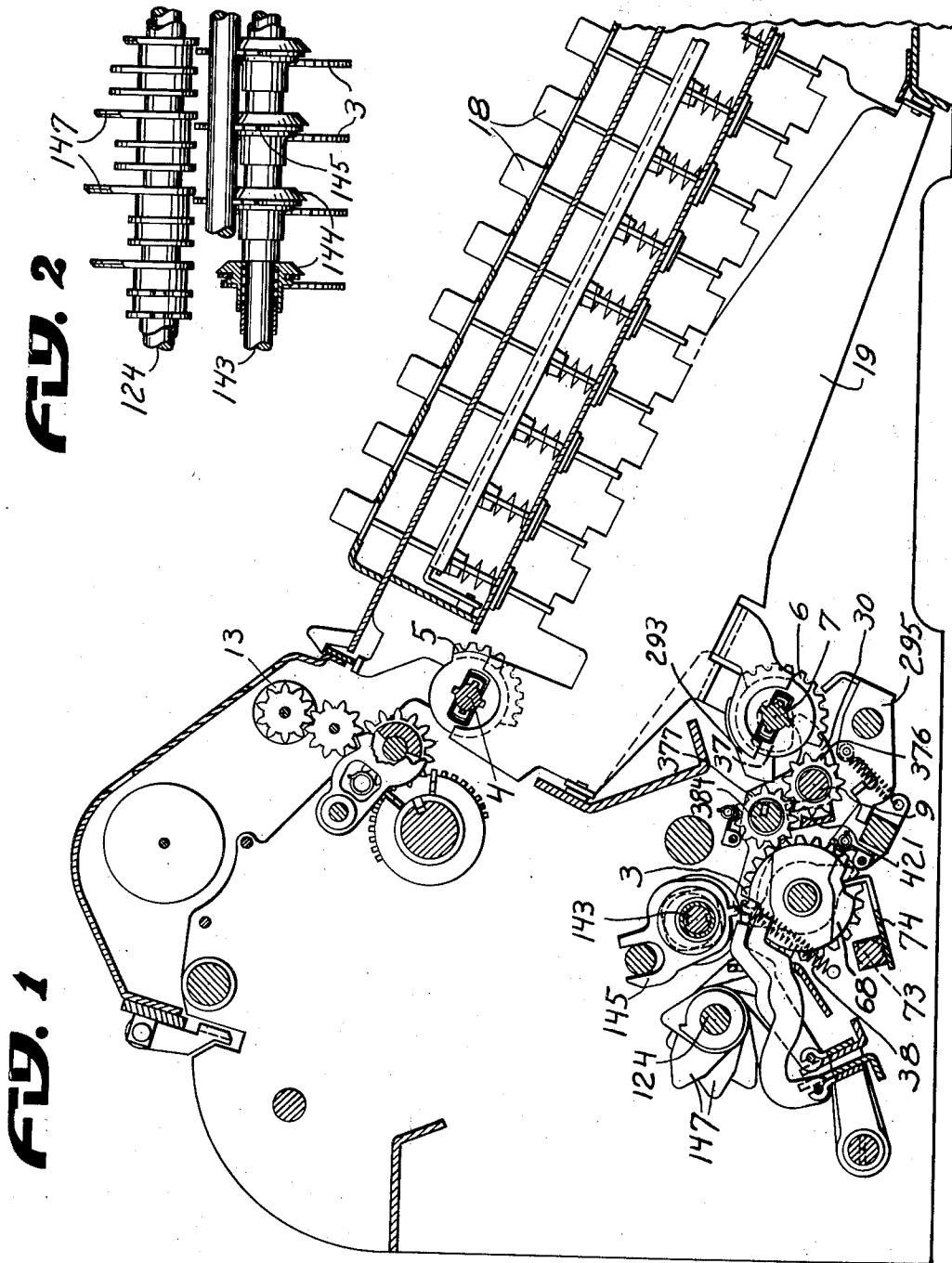

FIG. 1

FIG. 2

INVENTOR  
Edwin F. Britten, Jr.  
BY  
Strat Hilda ATTORNEY

May 21, 1940.

E. F. BRITTEN, JR

2,201,713

CALCULATING MACHINE

Filed Sept. 30, 1939

3 Sheets-Sheet 2

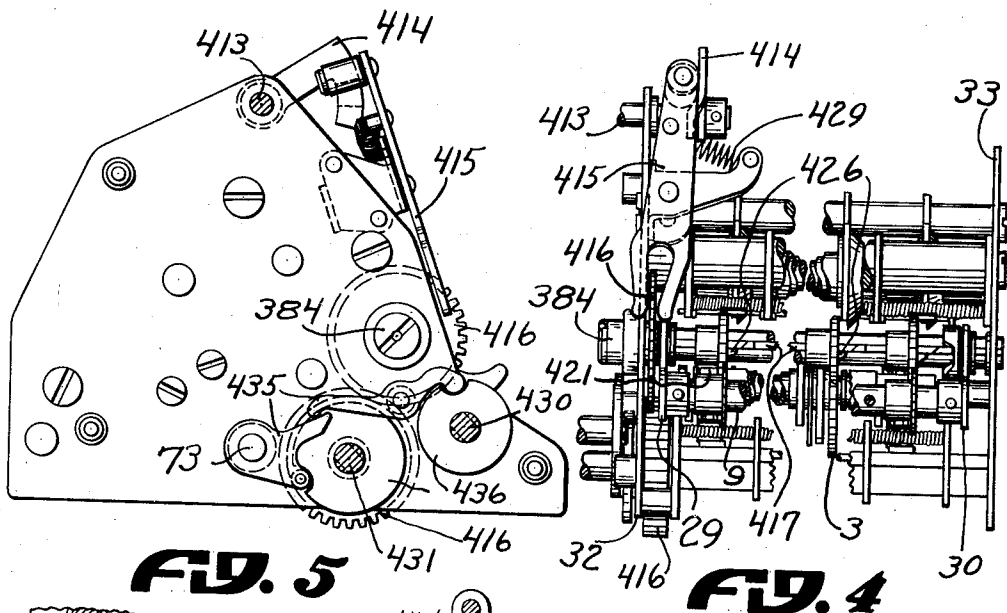

FIG. 5

FIG. 4

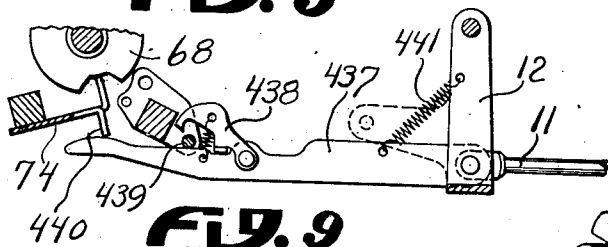

FIG. 9

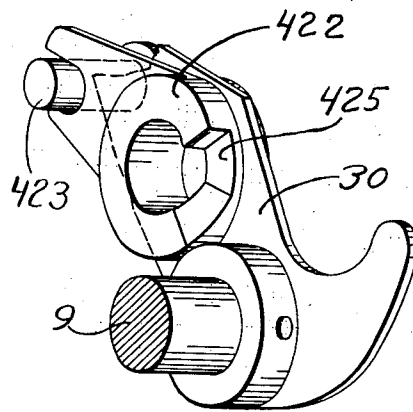

FIG. 6

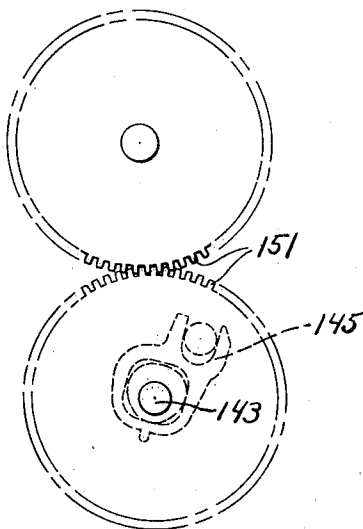

FIG. 3

INVENTOR  
Edwin F. Britten, Jr.  
BY  
Strauss & Hilde  
ATTORNEY

May 21, 1940.

E. F. BRITTEN, JR  
CALCULATING MACHINE

2,201,713

Filed Sept. 30, 1939

3 Sheets-Sheet 3

FIG. 8

FIG. 7

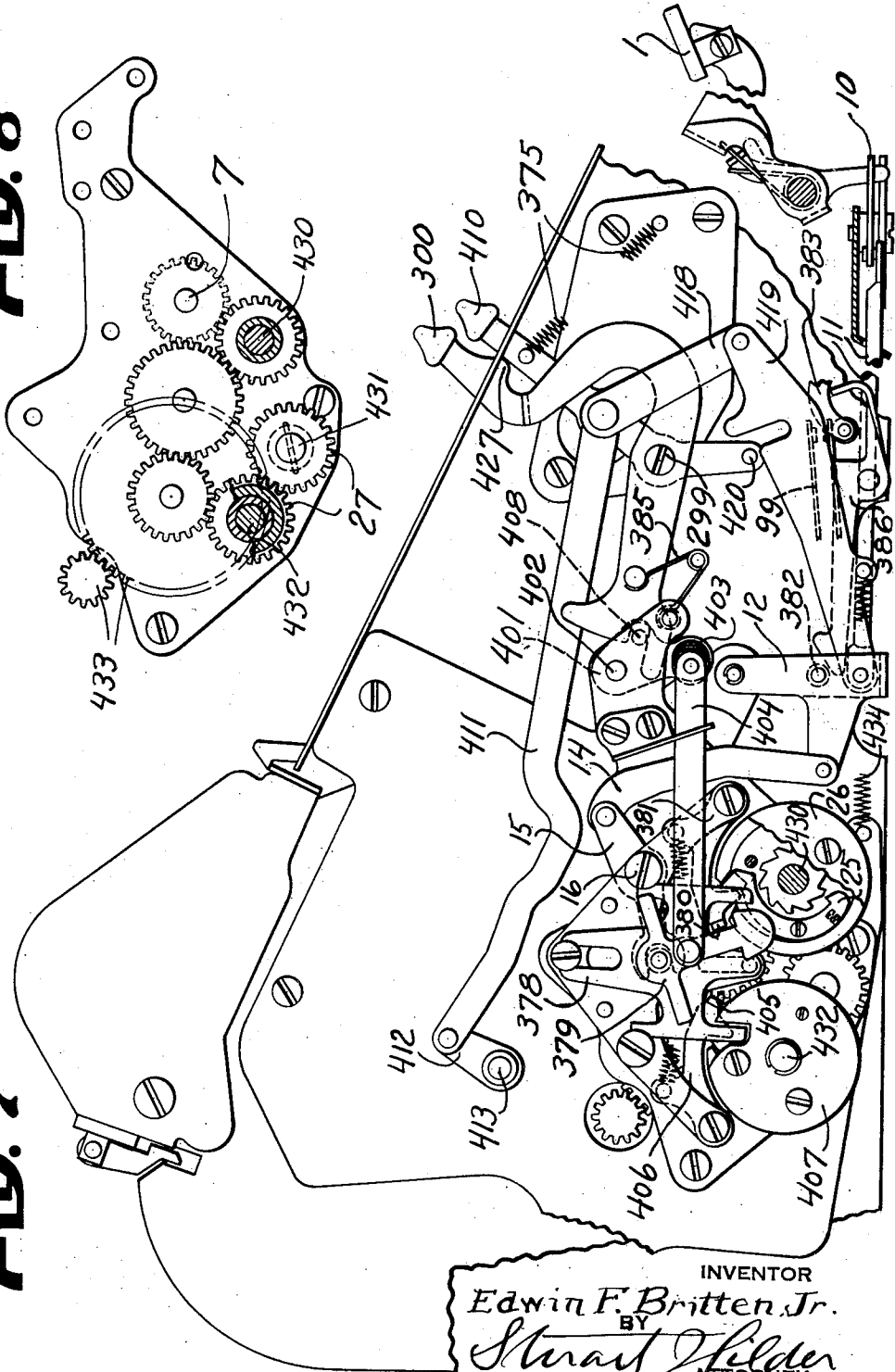

INVENTOR  
Edwin F. Britten, Jr.  
BY  
Stuart Fielder  
ATTORNEY

# UNITED STATES PATENT OFFICE

2,201,713

## CALCULATING MACHINE

Edwin F. Britten, Jr., Short Hills, N. J., assignor  
to Monroe Calculating Machine Company,  
Orange, N. J., a corporation of Delaware

Application September 30, 1939, Serial No. 297,234

6 Claims. (Cl. 235—79)

The invention relates to calculating machines adapted for multiplication by the repeated registration method, and more particularly to means whereby a complete multiplier may be set in wheels adapted to control the calculation, either directly through the value entering mechanism or from devices wherein a constant multiplier value has been stored.

The invention constitutes an improvement of the mechanism disclosed in co-pending application Serial No. 186,072 filed January 21, 1938, by Edwin F. Britten, Jr., and entitled "Calculating machines," and in the corresponding British Patent No. 509,747. Reference is made to these disclosures for the details of mechanisms for performing various functions of the machine not directly related to the present invention.

The invention consists in the novel construction and combination of parts as set forth in the appended claims.

In the accompanying drawings, illustrating the invention:

Fig. 1 is a vertical section through the keyboard, registering means and multiplier setting means of the machine.

Fig. 2 is a detail plan view of the multiplier counting out devices.

Fig. 3 is a detail elevation of the counting finger drive.

Fig. 4 is a fragmentary front elevation of the constant storage devices and associated parts.

Fig. 5 is a left side elevation of the same.

Fig. 6 is a detail perspective view of a portion of the intermediate gear shifting frame.

Fig. 7 is a left hand elevation of the machine, with casing removed and parts broken away, showing the multiplier setting controls.

Fig. 8 is a detail left side elevation of certain transmission gearing.

Fig. 9 is a detail elevation of the multiplier setting key lock.

In these drawings the numeral 18 (Fig. 1) designates a bank of value entering keys, adapted upon depression to rock bails 19 and thereby set selected values into the multiplicand register actuators 5 and into the multiplier control wheel actuators 6, a plurality of columns of these elements being provided, into which a complete multiplier, and thereafter a complete multiplicand, are entered.

The multiplier having been entered by means of the keys 18, shaft 7 will be given a single rotation, whereby the multiplier actuators 6 will transmit the values entered therein, through

intermediate gearing 376 and 377 to the multiplier control wheels 3.

The multiplicand is now entered in the actuators 5, through the keys 18, and the actuator shaft 4 is repeatedly rotated, under control of the wheels 3, giving a repeated registration of the multiplicand in the register wheels 13, to represent the product.

The wheels 3 are successively "counted out" or returned step by step to their original position by means of counting fingers 145 (Figs. 1, 2 and 3), mounted on a shaft 143 which has one-to-one ratio gear connection, 151, etc., with the multiplicand actuator shaft 4. The counting fingers 145 are normally held out of meshing relation with the teeth of wheels 3 by spring means, and are brought successively into meshing relation therewith during the calculation by means of projections 147 mounted on an intermittently rotated shaft 124, and adapted to engage the cam surfaces of guides 144, serving to slide the fingers 145 axially along shaft 143.

As the wheels 3 return to their original or zero position, control means will be operated to interrupt the cycling of shaft 4, the shifting of the register carriage and the resumption of cycling in the next ordinal position thereof, all in well-known manner. The patent and application hereinbefore referred to disclose one example of mechanisms operating in this manner.

According to the present invention, the constant multiplier value may be stored for future use in the intermediate transmission gears 377, to which end these gears are adapted to be shifted out of mesh with the teeth of the wheels 3, and are provided with zero setting means, whereby the wheels may be individually returned into a fixed or zero position.

The shaft 384 supporting the gears 377 is slideably and rotatably mounted in the machine frames 32, 33 (Fig. 4). The gears 376 and 377 are loosely mounted upon shafts 9 and 384 respectively and are located in lateral alignment by means of a comb 421, secured upon collars of levers 29, 30, in which collars the shaft 9 of the gears 376 is secured. Levers 29, 30 also engage collars carrying shafts 9 and 384, the levers 29, 30, shaft 9 and comb 421 forming a laterally shiftable frame on which the gears 376, 377 and the zero setting means are carried.

The zero setting means comprise zero teeth 426 projecting laterally from the gears 377 and a cooperating toothed slide 417 splined in the shaft 384 and movable into position to engage the teeth 426 by means of a cam 422, held against

rotation by pin 423 (Fig. 6) in frame 33, and forming part of the collar in which lever 30 is secured. In the normal position of shaft 384, the slide 417 is held to the right, as viewed in Fig. 4, out of engagement with the teeth 326, by means of a suitable spring, tending to hold the slide in engagement with the low point 425 of cam 422. A complete rotation of shaft 384 will cause slide 417 to pick up the wheels 377 individually, and return them to zero position.

If a value is to be retained as a constant, it is first entered by means of the keys 18, and is set in the wheels 3 in the usual manner. Thereafter, and before the calculation is begun, the intermediate transmission gears 377 are shifted out of mesh with the teeth of wheels 3, cleared to zero, and shifted back into mesh. Now, as the wheels 3 are counted back to zero during a calculation, the values are transferred therefrom into the gears 377. To set a stored multiplier value into the wheels 3, the gears 377 are cleared to zero while in mesh with the teeth of wheels 3, this operation taking the place of the setting of a key value by rotation of shaft 7. It is observed that after a constant has been stored in gears 377 other multiplier values may be entered by means of the keys 18, set in the control wheels 3 and counted out, without disturbing the constant, which may still be used whenever it may be desired. Further, it is to be noted that it will never be necessary to clear a constant from the gears 377 by a special operation, since the wheels are cleared in any case during the entering of a new constant.

The multiplier setting and constant storage operations are controlled as follows:

Actuator shaft 7 is connected with a clutch 26 supported on a shaft 430 (Figs. 7 and 8), and clearing shaft 384 is connected through gearing 416, shaft 431 and gearing 27 (Figs. 5 and 8) with a clutch 407, supported on a shaft 432. Clutches 26 and 407 are driven through gearing connections 433 from an electric motor. The clutches are of well-known design, adapted to give a single cycle of rotation to the driven shafts, and comprise driven clutch pawls 25, normally held against the tension of suitable springs by contact of detents 381 and 406, respectively, engaging the tails of the pawls. One or the other detent is lifted away from the related pawl by means of a rocker 379 pivotally mounted upon a sliding plate 378. Rocker 379 has a hook end held selectively in position to engage a lug 380 of detent 381 or a lug 405 of detent 406, upward movement of plate 378 serving to engage the hook end of the rocker with the lug of the detent and raise the detent free of pawl 25. As plate 378 reaches its upper position, one of two opposed arms of rocker 379 will contact with a related pin fixed in the framing of the machine, whereby the rocker will be centralized and the hook end thereof freed from the lug of the detent. The raised detent will therefore drop upon the periphery of a flanged extension of the driven clutch element, ready to drop into a notch of the flange and reengage the tail of pawl 25 as the clutch completes its rotation, whereupon the pawl will be withdrawn from the driving ratchet of the clutch and the driven parts brought to rest.

Rocker 379 is adjusted for operation of clutch 26 or clutch 407 by means of a link 404, yieldably connected with a lever 401, fulcrumed at 402, by means of a coil spring 403, one end of which is clamped to the link and the other end to the lever. Lever 401 is operated by a hand lever 300, having

an arm extending through the casing of the machine and another arm engaging a pin 408 of lever 401. Lever 300 is held in either of its two adjusted positions by means of a toggle spring 385, whereby the rocker 379 is held in adjusted position.

Plate 378 is raised, to operate the selected clutch, by means of a lever 15, fulcrumed at 16, link 14 and lever 12. An operating key 1 has connection through whiffletree 10 and link 11 with the lever 12, depression of said key serving to rock lever 12 against the tension of a spring 434 and thereby to raise the plate 378 to engage the clutch. Rocking of lever 12 will also, by means of a pin 382, rock levers 386 and 383, to close the contacts of a circuit breaker 99, interposed in the motor circuit.

In the position of the parts illustrated in Fig. 7, that is to say, with the operating knob of lever 300 located in its forward position, depression of key 1 will operate clutch 26 and thereby rotate the actuators 6, to set a value entered in said actuators into the multiplier control wheels.

Setting of the constant is controlled by a hand lever 410, this lever operating to shift the gears 377 out of mesh with the teeth of the multiplier control wheels; to throw lever 300 into its rearward position, thereby providing for the operation of clutch 407, and to rock lever 12 to operate the clutch.

Lever 410 is fulcrumed, in common with lever 300 at point 299, and is connected by means of a link 411 with an arm 412, fast upon shaft 413 (Figs. 5 and 7), shaft 413 having a cam arm 414 engaging a roller fixed on the end of a shipper lever 415 (Figs. 4 and 5). Shipper 415 engages the gear 416 which is mounted on the fixed collar supporting the lever 28 of the shiftable frame 384, 29, 9, 421, 30. Rearward movement of the operating button of lever 410 will, therefore, move the shifting frame to the right as seen in Fig. 4, to disengage the gears.

Lever 410 also engages a spur 427 of lever 300, carrying the operating arm of that lever backward along with the operating arm of lever 410, and thus positioning the hooked end of rocker 379 below the lug 405 of detent 406 related to clutch 407.

Lever 410 has a lower arm provided with a pin 420 adapted to engage a contacting face of a link 419, one end of which is connected to the lever 12 and the other end of which has link connection 418 with lever 410. Movement of lever 410 to operated position will, therefore, move link 419 forwardly and thereby rock levers 12 and 15, to raise the plate 378 and operate the clutch.

By means of the above noted connections, operation of lever 410, after a value has been set in the multiplier control wheels, will prepare the gears 377 for the storage of a constant, by clearing the multiplier value out of said gears while they are disengaged from the multiplier control wheels.

Upon release of lever 410 by the operator, it will be returned to normal position by a spring 375, leaving lever 300 set in rearward position, and allowing the shifting frame to be returned to normal position by a spring 429 acting upon the shipper 415. In this position of the parts, depression of key 1 will operate clutch 407, to set the multiplier wheels in accordance with a stored constant. Lever 300 may be adjusted back and forth between these two positions, as may be necessary in carrying out the desired calculations, the constant being set by operation of the key 1 whenever the lever is in rearward position, and

the constant ignored and a key entered value set by the depression of key 1 whenever the lever is in its forward position.

A feeling bail (Fig. 1) is provided with teeth engaging zero notches of cams 68, fast to the multiplier control wheels 3, this bail being held in rocked position so long as any value remains set in any of the multiplier wheels, and having control connections, set forth in the disclosures of the application and patent above referred to, for insuring the operation of the machine until the entire multiplier has been counted out. Bail 74 has connection through shaft 73 with a pair of rocker arms 435 (Fig. 5), engaging notched plates 436 secured to the shafts 430 and 431. Therefore, operation of either of the clutches 26, 407 will serve to rock shaft 73 and lift the teeth of bail 74 out of the notches of cams 68, just previous to the value setting operation.

A lock cooperates with feeling bail 74 to prevent operation of key 1 or lever 410 so long as a multiplier value remains set in the control wheels 3. This lock comprises a lever 437 (Fig. 9), fulcrumed upon the lever 12 and carrying a spring urged locking pawl 438, normally located above a pin 439, fixed in the machine framing. Bail 74 is provided with a lug 440, against which lever 437 is held in contact by means of a spring 441. When bail 74 is moved out of the notches of cams 68, locking pawl 438 is moved downward, toward pin 439, snapping into position behind said pin as soon as lever key 1 or lever 410 is released, and acting to lock said key and said lever against further operation, so long as any of the teeth of bail 74 are held upon the outer peripheral portions of the related cams 68.

When the constant mechanism herein set forth is used in connection with the multiplier devices of U. S. patent application Serial No. 186,072 and British Patent No. 509,747, certain modifications of the control means are necessary, which, although not directly involved in the present invention, are herein set forth for the purpose of completing the disclosure.

The disclosures of the above noted patent and application provide for short-cutting the product calculation, by treating the higher value multiplier digits complementally. That is to say, a calculation involving the multiplier 9 will be effected as plus 10 minus 1, in two cycles of operation.

The means for determining the sign character of the registration has not been modified, but the setting of the unit in the higher order multiplier control wheel is herein effected by means of a projection 293 (Fig. 1), fixed on one of the actuator elements 6, contacting with a finger 295 provided with a tooth extending into the zone of the higher order wheel 376. Projection 293 having brought tooth of finger 295 between the teeth of gear 376, a cam 37, mounted on shaft 7, will engage the forward projection of the lever 30, rocking the levers 29 and 30 of the gears 376 about shaft 384, and thereby causing such of the gears 376 as are engaged by a finger 295 to advance an additional step of movement. Thereafter, the fingers 295 will be released from the projections 293 and allowed to drop back to normal position under the influence of their springs, whereafter, cam 37 will release lever 30, which will be returned to normal position and held therein by means of a spring 38.

I claim:

1. In a calculating machine adapted for multiplication by the repeated registration method

and having digit entering means including differential actuators, multiplier control wheels settable by said actuators, and means for counting out values set in said wheels; intermediate transmission gears mounted in fixed ordinal relation to said control wheels, relatively adjustable out of and into mesh therewith and operable by said differential actuators, means for effecting relative adjustment of said intermediate gears and control wheels, and clearing means including zero teeth on the intermediate gears and elements operable in either relatively adjusted position thereof to determine the storage of a constant multiplier value or to effect the setting of the multiplier control wheels in accordance with said value.

2. In a calculating machine adapted for multiplication by the repeated registration method and having digit entering means including differential actuators, multiplier control wheels settable by said actuators, and means for counting out values set in said wheels; intermediate transmission gears mounted in fixed ordinal relation to said control wheels, adjustable out of and into mesh therewith and operable by said differential actuators, means for adjusting said intermediate gears, and clearing means including zero teeth on the intermediate gears and teeth adjustable with said gears and operable in either position of adjustment to engage the zero teeth to determine the storage of a constant multiplier value or to effect the setting of the multiplier control wheels in accordance with said value.

3. In a calculating machine adapted for multiplication by the repeated registration method and having digit entering means including differential actuators, multiplier control wheels settable by said actuators, and means for counting out values set in said wheels; intermediate transmission gears mounted in fixed ordinal relation to and normally meshing with said control wheels, relatively adjustable out of mesh therewith and operable by said differential actuators, clearing means including zero teeth on the intermediate gears and cooperating elements operable in either relatively shifted position thereof, manually controlled means for relatively adjusting said intermediate gears to unmeshed position and for operating the clearing means, whereby the intermediate gears may be prepared to store as a constant a value previously set in the control wheels, and manually controlled means for operating the clearing means to set the control wheels in accordance with a stored constant value.

4. In a calculating machine adapted for multiplication by the repeated registration method and having digit entering means including differential actuators, motor drive means for said actuators including a clutch, multiplier control wheels settable by said actuators, and means for counting out values set in said wheels; intermediate transmission gears mounted in fixed ordinal relation to and normally meshing with said control wheels, relatively adjustable out of mesh therewith and operable by said differential actuators, manually controlled means for relatively adjusting said intermediate gears to unmeshed position, clearing means including zero teeth on the intermediate gears and cooperating elements operable in either relatively shifted position thereof, motor operating connections for said clearing means including a clutch, a motor key, a lever, and means settable by said lever to connect said key with the actuator clutch or alternatively with the clearout clutch, to control the setting in the

multiplier control wheels of a value entered in the actuators or of a value stored as a constant in the intermediate transmission gears.

5 5. In a calculating machine adapted for multi-  
plication by the repeated registration method  
and having digit entering means including differ-  
ential actuators, motor drive means for said actu-  
ators including a clutch, multiplier control wheels  
10 10 settable by said actuators, and means for count-  
ing out values set in said wheels; intermediate  
transmission gears mounted in fixed ordinal rela-  
tion to and normally meshing with said control  
wheels, relatively adjustable out of mesh there-  
with and operable by said differential actuators,  
15 15 clearing means including zero teeth on the inter-  
mediate gears and cooperating elements operable  
in either relatively shifted position thereof, motor  
operating connections for said clearing means  
including a clutch, a motor key, a lever, means  
20 20 settable by said lever to connect said key with  
the actuator clutch or alternatively with the

clearout clutch, to control the setting in the  
multiplier control wheels of a value entered in  
the actuators or of a value stored as a constant  
in the intermediate transmission gears, and a  
lever manually operable to relatively adjust the  
intermediate gears to unmeshed position, to set  
5 5 the first named lever to clearout position and to  
actuate the clearout clutch.

6. In a calculating machine adapted for multi-  
plication by the repeated registration method and  
having digit entering means including differential  
10 10 actuators, motor drive means for said actuators  
including an operating key, multiplier control  
wheels settable by said actuators, and means for  
counting out values set in said wheels; means  
including a displaceable feeler adapted to sense  
15 15 the presence of a value in the control wheels,  
and a lock held in operated position by the dis-  
placed feeler to prevent depression of said oper-  
ating key.

EDWIN F. BRITTEN, JR. 20