

Oct. 31, 1950

S. G. STAPLEY ET AL  
PULPING MACHINE

2,527,772

Filed May 6, 1947

2 Sheets-Sheet 1

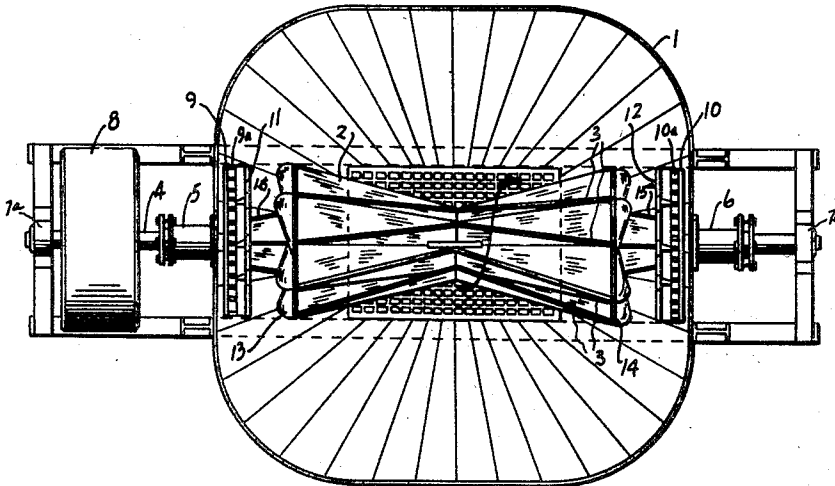

FIG 1

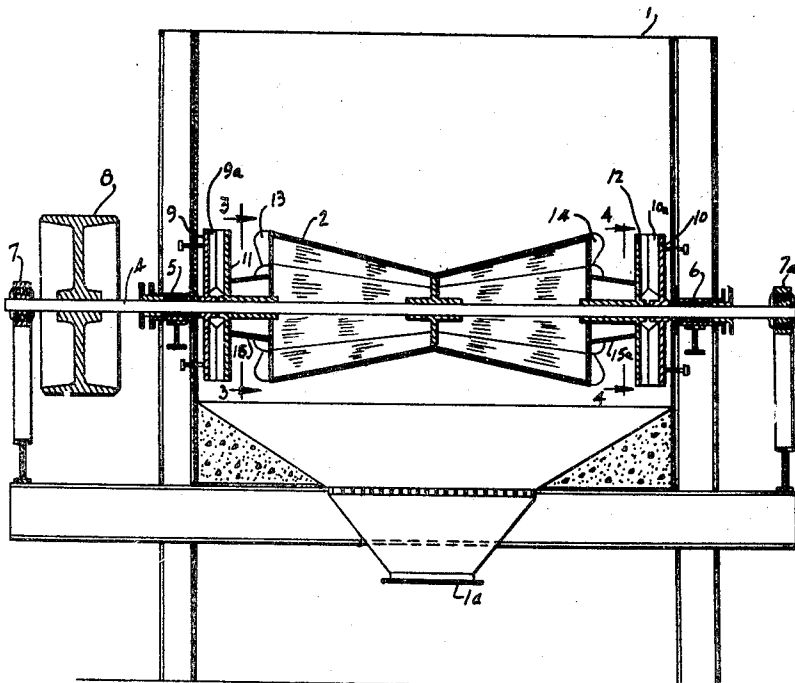

FIG 2

STEPHEN GEORGE STAPLEY  
AND WILLIAM SUBART  
INVENTOR

by Gareth E. Mayhew  
attorney

Oct. 31, 1950

S. G. STAPLEY ET AL  
PULPING MACHINE

2,527,772

Filed May 6, 1947

2 Sheets-Sheet 2

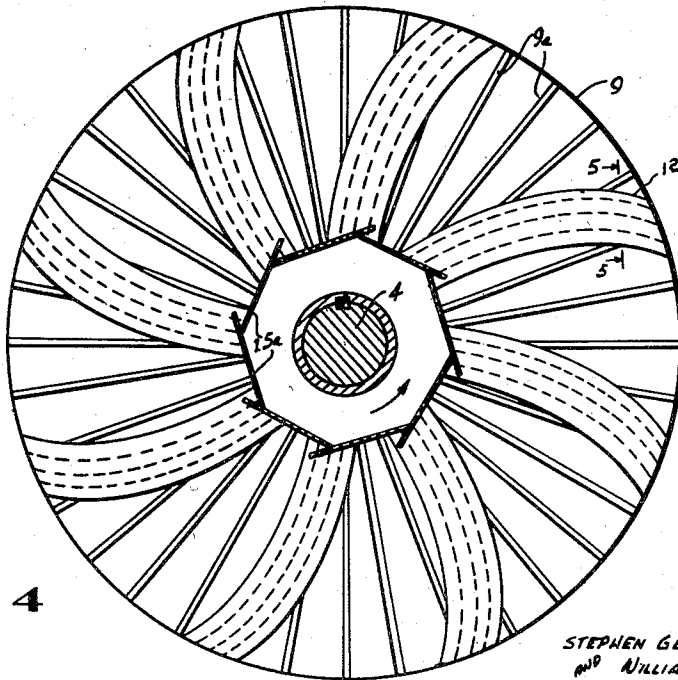
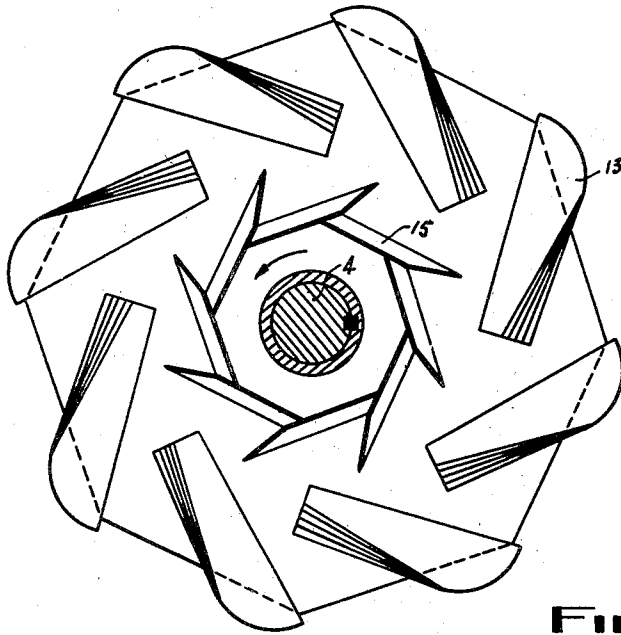

STEPHEN GEORGE STAPLEY  
AND WILLIAM SUART  
INVENTOR

by *Gareth E. Haylee*  
Attorney

# UNITED STATES PATENT OFFICE

2,527,772

## PULPING MACHINE

Stephen G. Stapley, Thorold, and William Subart,  
Merritton, Ontario, Canada, assignors to E. D.  
Jones & Sons Company, Pittsfield, Mass., a cor-  
poration of Massachusetts

Application May 6, 1947, Serial No. 746,398

4 Claims. (Cl. 92-26)

1

This invention relates to an improved pulping machine for use in disintegrating pulp and paper of all kinds and sizes and is particularly adapted for use in the reclaiming of paper from books, magazines, newspapers and the like.

The object of this invention is to devise a machine which will rapidly break up the stock which is fed to it and grind it to the required size.

A further object of the invention is to devise a pulping machine which is economical in operation, simple in construction, and which will handle all kinds and sizes of stock quickly and efficiently. A further object of the invention is to devise a pulping machine which will not become blocked or clogged by the accumulation of material passing through it.

The objects of the invention are achieved by providing, within a stock tank, a rotatable drum or roll which will break up the material and carry it to the outer ends of the drum, where means is provided for catching the stock and directing it to cutting or grinding means where it is further disintegrated. The machine is constructed so that the disintegrating process is carried on within the tank and the material is not passed through small passages where clogging or blocking may take place.

The invention is hereinafter more particularly described and is illustrated by way of example in the annexed drawings in which:

Fig. 1 is a plan view of the stock tank, showing the pulping mechanism mounted therein;

Fig. 2 is a vertical section through the apparatus;

Fig. 3 is an end view of the drum, on the line 3-3 in Fig. 2 on an enlarged scale;

Fig. 4 is a section on the line 4-4 in Fig. 2, showing the rotatable and stationary cutting or grinding means; and

Fig. 5 is a fragmentary section through the cutting or grinding means on the line 5-5 in Fig. 4.

In the drawings, corresponding numbers refer to corresponding parts in the different figures.

The stock of pulp mixture is contained in the tank 1, which has an open top through which the material to be disintegrated is thrown into the tank. The tank can be of any suitable structure and is provided with an opening 1a in the bottom thereof for drawing off the ground stock.

The grinding or pulping drum 2 is mounted near the bottom of the tank, but spaced therefrom a sufficient distance to provide free circulation of the stock on all sides of the drum. This drum 2 is formed of two frusto-conical octagonal

2

members or sections having their small ends secured together and their big ends located adjacent the sides of the tank. A series of ribs 3 extend longitudinally and diagonally from the small ends of the frusto-conical portions of the drum to their big ends. These ribs serve to beat and break up the stock when it comes in contact with them. Owing to the conical formation of the drum, the stock which comes in contact with the drum tends to flow outwardly from the small inner portion thereof to the big ends.

The drum 2 is uncased and is mounted on a transverse shaft 4 which is journaled in bearings 5 and 6 in the side walls of the container 1. The shaft extends beyond the sides of the container 1 and its outer ends are journaled in brackets 7 and 7<sup>a</sup> suitably mounted on a supporting frame. Keyed to the shaft is a pulley 8 adapted to be driven from a motor or other source of power to rotate the shaft and the drum.

The big ends of the drum are spaced from the side walls of the container 1. Secured to the side walls are fixed grinding members 9 and 10 coaxial with the shaft 4. These grinding members comprise plates on the face of which are mounted radial ribs 9<sup>a</sup> and 10<sup>a</sup>.

Mounted on the shaft 4 and spaced longitudinally of the shaft from the ends of the drum are rotatable grinding members 11 and 12, opposite the fixed grinding members 9 and 10 respectively and spaced therefrom. As shown in Fig. 5, the forward or leading edge of rotatable grinding members slope inwardly towards the fixed grinding members tending to throw the material inwardly towards the ribs 9<sup>a</sup> and 10<sup>a</sup> of the fixed grinding members. The rotatable grinding members consist of radial curved spaced apart blades such as shown in Figs. 2 and 4. They are not solid discs. The stock passing between these blades is ground between them and the fixed grinding members to the desired size.

A plurality of blades 13 and 14 as shown in Figs. 2 and 3 project outwardly from the big ends of the drum 2 between said ends and the grinding elements and are adapted to catch the stock as it travels outwardly along the periphery of the drum and direct it to and between the grinding members 9 and 11 and 10 and 12. The blades 13 and 14 are of elongated rectangular shape with their outer corners rounded. They are secured to the big ends of the drum diagonally thereof, that is to say at an angle to a line bisecting the longitudinal axis of the drum, and are welded along their two inner edges to the ends of the drum extending outwardly therefrom at

& less than 90° angle to form scoops which catch the stock and throw it towards the grinding means when the drum is rotated.

To break up the stock which might tend to clog or wind around the shaft, cutter blades 15 and 15<sup>a</sup> as shown in Figs. 2 and 4 are secured at opposite ends of the drum 2. These cutter blades extend diagonally out from the ends of the drum and have sharp beveled ends which cut into the stock when the drum rotates.

In operation, if dry stock is used, which is usually the case, the tank will be filled with liquid to or above the top of the drum. The drum is then set in motion. This creates a violent agitation in the tank and water is thrown up the sides of the tank directly over the grinding members. The stock is then dropped in bulk form into the tank from the top of the tank. Inasmuch as the invention is particularly adapted to the pulping of used paper, the stock may consist of old books, magazines, newspapers and the like. The stock is drawn into the center of the rotor by suction and forms a large ball which revolves around the small part of the drum and is very quickly broken into somewhat smaller balls or wads of unbroken material. Since the rotor is conical in shape outwardly from the center thereof, the speed of the rotor at the periphery of its big end is much greater than the speed of the rotor at the center, in practice more than twice the speed. This creates a circulation outwardly from the center of the drum towards the big ends and the wads are very quickly forced toward the ends of the drum toward the scoops. At this stage the wads or balls of materials which are too large to be picked up by the scoops are thrown back towards the center of the tank and this process may be repeated several times over until the larger lumps are reduced to small particles which can be picked up by the scoops and directed into the grinding members.

The grinding members comprise rotary blades and fixed ribbed plates. The rotary blades have a clear discharge area in all directions radially from their periphery and therefore are capable of discharging at great capacity. At the same time, a strong suction is created transversely of the rotary blades, which suction is strongest adjacent the hubs of the blades. Thus, there is a circulatory movement from the big ends of the blades inwardly of the drum into the space between the ends of the drums and the grinders and outwardly of the drum to and between the rotary grinder blades. This movement is assisted by the scoops which are secured to the ends of the drums and extend inwardly from the outer periphery of the ends of the drums. Since their outer ends are rotating at a greater speed than their inner ends, a suction is created which carries any particles small enough to pass between the scoops inwardly from the outer peripheries of the big ends of the drums, where pressure created at the inner or discharge ends of the scoops and the suction created by the rotary grinding blades assisted by the sloping sides of the ribs of said blades carries the material between the said rotary grinding blades and grinds it against the stationary ribbed grinding member.

The above cycle of operation is repeated over and over again, depending upon the kind of material being pulped and the extent of grinding required. The drums are well spaced from the bottom of the tank since it is important to have free movement for large wads or balls of material all around the pulping drums in order that

the circulatory action referred to above may not be impeded and there may be no jamming of material between the rotary parts of the apparatus and the bottom of the drums.

Although preferably the drum is double ended, i. e. comprises two aligned frusto-conical members, a single conical member may be used. A cylindrical drum may be used with less efficiency, since the scoop blades tend to draw the stock from the drum even without the additional outward throw caused by the conical form of the drum. The ribs which extend longitudinally of the drum are preferably diagonal, since this form also tends to direct the stock to the ends of the drum, but may be axial.

It is thought that the construction and use of the invention will be apparent from the above description of the various parts and their purpose. It is to be understood that the form of the invention shown and described is to be taken as preferred example of the same, and that various changes in the shape, size and arrangement of parts may be resorted to without departing from the spirit of the invention or the scope of the subjoined claims.

We claim:

1. A pulping machine comprising in combination, a tank having adjacent and opposite end and side walls, a shaft extending from one side wall to the other side wall of said tank and journaled in said side walls for rotation, a drum and said tank fixed on said shaft and being in the form of two elongated tubular frusto-conical sections having inner adjacent small ends intermediate opposite ends of said drum and imperforate side walls relatively diverging therefrom to relatively large outer ends and imperforate end walls secured to the outer ends of said side walls cooperating therewith to provide a completely enclosed hollow drum, said end walls of said drum disposed inwardly from said side walls of said tank adjacent thereto providing spaces therebetween, a plurality of longitudinal circumferentially spaced radially extending ribs secured to the outer sides of said drum and extending in opposite directions from the mid-section of said drum to the outer ends thereof and being disposed in longitudinal and diagonal relation thereon, fixed grinding members secured to the side walls of said tank at opposite ends of said drum having circumferentially spaced radially extending ribs, rotatable grinding members on said shaft spaced outwardly from opposite ends of said drum and adjacent said fixed grinding members and including circumferentially spaced radially curving portions provided with outer faces for coacting with the ribs of said fixed grinding members, and a plurality of circumferentially spaced blades secured to and extending outwardly from said end walls of said drum into the spaces between the ends of said drum and adjacent side walls and spaced inwardly away from said rotatable grinding members and disposed generally radially and tangentially relative to the axis of rotation of said drum.

2. A pulping machine comprising in combination, a tank having adjacent and opposite end and side walls, a shaft extending from one side wall to the other side wall of said tank and journaled in said side walls for rotation, a drum in said tank fixed on said shaft and being in the form of two elongated tubular frusto-conical sections having inner adjacent small ends intermediate opposite ends of said drum and imperforate side walls relatively diverging therefrom

to relatively large outer ends, imperforate end walls secured to the outer ends of said side walls cooperating therewith to provide a completely enclosed hollow drum and being disposed inwardly from said side walls of said tank adjacent thereto providing spaces therebetween, a plurality of longitudinal circumferentially spaced radially extending ribs secured to the outer sides of said drum and extending in opposite directions from the mid-section of said drum to the outer ends thereof and being disposed in longitudinal and diagonal relation thereon, fixed grinding members secured to the side walls of said tank at opposite ends of said drum having circumferentially spaced radially extending ribs, rotatable grinding members on said shaft spaced outwardly from opposite ends of said drum and adjacent said fixed grinding members and including circumferentially spaced radially curving portions provided with outer faces for coacting with the ribs of said fixed grinding members, a plurality of circumferentially spaced blades secured to and extending outwardly from said end walls of said drum into the spaces between said drum and adjacent side walls and spaced inwardly away from said rotatable grinding members and disposed generally radially and tangentially relative to the axis of rotation of said drum, and longitudinally extending circumferentially spaced cutter blades in the spaces between the ends of said drum and rotatable grinding members secured thereto and rotatable therewith.

3. A pulping machine comprising in combination, a tank having adjacent and opposite end and side walls, a shaft extending from one side wall to the other side wall of said tank and journaled in said side walls for rotation, a drum in said tank fixed on said shaft and being in the form of two elongated tubular frusto-conical sections having inner adjacent small ends intermediate opposite ends of said drum and imperforate side walls relatively diverging therefrom to relatively large outer ends, imperforate end walls secured to the outer ends of said side walls cooperating therewith to provide a completely enclosed hollow drum and being disposed inwardly from said side walls of said tank adjacent thereto providing spaces therebetween, a plurality of circumferentially spaced radially extending ribs secured to the outer sides of said drum and extending in opposite directions from the mid-section of said drum to the outer ends thereof, fixed grinding members secured to the side walls of said tank at opposite ends of said drum having circumferentially spaced radially extending ribs, rotatable grinding members on said shaft spaced outwardly from opposite ends of said drum and adjacent said fixed grinding members and including circumferentially spaced radially curving portions provided with outer faces for coacting with the ribs of said fixed grinding members, and a plurality of circumferentially spaced blades secured to and extending outwardly from said end walls of said drum into the spaces between said drum and adjacent side walls and spaced inwardly away from said rotatable grinding members

and disposed generally radially and tangentially relative to the axis of rotation of said drum.

4. A pulping machine comprising in combination, a tank having side and end walls, a shaft extending from one side wall to the other side wall of said tank and journaled in the side walls for rotation, a drum in said tank fixed on said shaft being in the form of two elongated tubular frusto-conical sections having inner adjacent small ends intermediate opposite ends of said drum and imperforate side walls relatively diverging therefrom to relatively large outer ends, imperforate end walls secured to the outer ends of said side walls cooperating therewith to provide a completely enclosed hollow drum, said end walls of said drum being disposed inwardly from side walls of said tank adjacent thereto providing spaces therebetween, a plurality of circumferentially spaced radially extending ribs secured to the outer sides of said drum and extending in opposite directions from the mid-section of said drum to the outer ends thereof, fixed grinding members secured to the side walls of said tank at opposite ends of said drum having circumferentially spaced radially extending ribs, rotatable grinding members on said shaft spaced outwardly from opposite ends of said drum and adjacent said fixed grinding members and including circumferentially spaced radially curving portions provided with outer faces for coacting with the ribs of said fixed grinding members, a plurality of circumferentially spaced blades secured to and extending outwardly from the end walls of said drum into the spaces between the ends of said drum and adjacent side walls and spaced inwardly away from said rotatable grinding members and disposed generally radially and tangentially relative to the axis of rotation of said drum, and longitudinally extending circumferentially spaced cutter blades in the spaces between the ends of said drum and rotatable grinding members secured thereto and rotatable therewith.

STEPHEN G. STAPLEY.  
WILLIAM SUBART.

#### REFERENCES CITED

The following references are of record in the file of this patent:

#### UNITED STATES PATENTS

Number	Name	Date
342,802	Marshall	June 1, 1886
381,515	Winchell	Apr. 17, 1888
447,853	Wagg	Mar. 10, 1891
620,884	Cadwgan	Mar. 14, 1899
963,353	Blake	July 5, 1910
1,074,844	Dellinger	Oct. 7, 1913
1,187,932	Ryther	June 20, 1916
1,775,743	Wiener	Sept. 16, 1930
2,129,789	Seaborne	Sept. 13, 1938
2,433,490	Stapley et al.	Dec. 30, 1947

#### FOREIGN PATENTS

Number	Country	Date
8,664	Great Britain	of 1897