



- (51) International Patent Classification:
E06B 3/46 (2006.01)
- (21) International Application Number:
PCT/EP2013/069708
- (22) International Filing Date:
23 September 2013 (23.09.2013)
- (25) Filing Language: English
- (26) Publication Language: English
- (30) Priority Data:
TV 2012 U 000057
11 December 2012 (11.12.2012) IT
- (71) Applicant: ECLISSE S.R.L. [IT/IT]; Via Semaglia, 76, I-31053 Pieve Di Soligo (IT).
- (72) Inventor: DE FAVERI, Luigi; Via Vittoria, 114, I-31020 Refrontolo (IT).
- (74) Agent: MODIANO, Micaela; Modiano & Partners, Via Meravigli, 16, I-20123 Milano (IT).

- (81) Designated States (unless otherwise indicated, for every kind of national protection available): AE, AG, AL, AM, AO, AT, AU, AZ, BA, BB, BG, BH, BN, BR, BW, BY, BZ, CA, CH, CL, CN, CO, CR, CU, CZ, DE, DK, DM, DO, DZ, EC, EE, EG, ES, FI, GB, GD, GE, GH, GM, GT, HN, HR, HU, ID, IL, IN, IS, JP, KE, KG, KN, KP, KR, KZ, LA, LC, LK, LR, LS, LT, LU, LY, MA, MD, ME, MG, MK, MN, MW, MX, MY, MZ, NA, NG, NI, NO, NZ, OM, PA, PE, PG, PH, PL, PT, QA, RO, RS, RU, RW, SA, SC, SD, SE, SG, SK, SL, SM, ST, SV, SY, TH, TJ, TM, TN, TR, TT, TZ, UA, UG, US, UZ, VC, VN, ZA, ZM, ZW.
- (84) Designated States (unless otherwise indicated, for every kind of regional protection available): ARIPO (BW, GH, GM, KE, LR, LS, MW, MZ, NA, RW, SD, SL, SZ, TZ, UG, ZM, ZW), Eurasian (AM, AZ, BY, KG, KZ, RU, TJ, TM), European (AL, AT, BE, BG, CH, CY, CZ, DE, DK, EE, ES, FI, FR, GB, GR, HR, HU, IE, IS, IT, LT, LU, LV, MC, MK, MT, NL, NO, PL, PT, RO, RS, SE, SI, SK, SM, TR), OAPI (BF, BJ, CF, CG, CI, CM, GA, GN, GQ, GW, KM, ML, MR, NE, SN, TD, TG).

[Continued on next page]

(54) Title: FRAMEWORK FOR WALLS OR SLABS MADE OF PLASTERBOARD

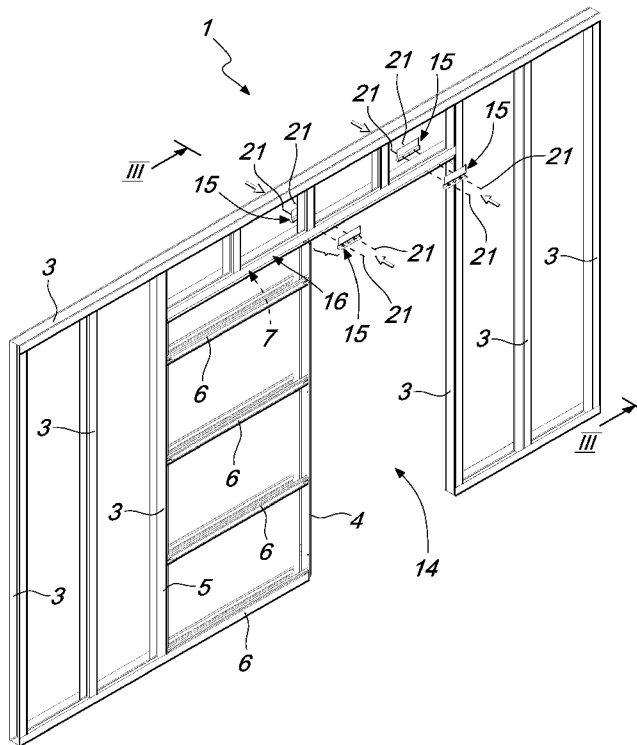

Fig. 1

(57) Abstract: A framework (1) for walls or slabs (2) made of plasterboard, of the type comprising a plurality of vertical or horizontal profiled elements (3), a front upright member (4), and a rear upright member (5), which are connected by horizontal crossmembers (6). The framework is constituted by a first element (7) adapted to act as an upper lintel for the front and rear upright members (4, 5) and also by a rail/guide for sliding trolleys for supporting a door. The framework is further constituted by brackets (15) for centering an upper framework and for support for plasterboard slabs (2).

WO 2014/090430 A1

Published:

— *with international search report (Art. 21(3))*

FRAMEWORK FOR WALLS OR SLABS MADE OF PLASTERBOARD

The present invention relates to a framework for walls or slabs made of plasterboard.

Nowadays it is known to provide door frames which involve the use
5 of a casing, positioned inside a wall, in which a door or a panel is slideably integrated and which is also known as a "retractable door".

Such a solution makes it possible to reduce the encumbrances of the door in a room thanks to the possibility of sliding it into the casing: thus one can use the space adjacent to the door, which would otherwise be occupied
10 by doors of the type that are hinged laterally to a casement.

In the known art, the casing embedded in the wall is usually constituted by a framework which comprises a plurality of vertical profiled elements, a front upright member and a rear upright member, which are connected by horizontal crossmembers which define a containment case of
15 the panel or of the door; with the application of an outer net on the containment case, the plaster can then be applied.

Protruding above the case, along an axis that is longitudinal with respect to the case itself and that extends from the side opposite to that of the containment case, there is a rail which is hidden by a jamb.

20 Trolleys coupled to the upper edge of the door are slideably integrated in the rail in order to enable the sliding of the door into and out of the casing.

Usually associated with the end of the rail which is not associated with the vertical posts is an additional upright member that acts as a
25 terminal for the abutment of the front edge of the door.

A problem that is encountered in the use of such solutions consists in the complexity both in construction and in installation.

The aim of the present invention is therefore to resolve the above-mentioned technical problems, eliminating the drawbacks in the cited
30 known art and thus devising a framework that can be used for walls made of

plasterboard and that offers considerable simplicity in terms of construction and installation.

Within this aim, an object of the invention is to provide a framework that can be used for walls made of plasterboard and that offers excellent
5 functionality and strength.

Another object is to provide a framework that can be used for walls made of plasterboard and that can be installed even by people with no special training.

Another object is to provide an invention that is structurally simple,
10 can be provided with conventional systems and machines, and is low-cost.

This aim and these and other objects which will become more apparent hereinafter are achieved by a framework for walls or slabs made of plasterboard, which comprises a plurality of vertical or horizontal profiled elements, a front upright member, and a rear upright member, which are
15 connected by horizontal crossmembers, characterized in that it is constituted by a first element adapted to act as an upper lintel for said front upright member and said rear upright member and also by a rail/guide for sliding trolleys for supporting a door, said framework being furthermore constituted by brackets for centering an upper framework and for support for walls or
20 slabs made of plasterboard.

Further characteristics and advantages of the invention will become more apparent from the detailed description of a particular, but not exclusive, embodiment, illustrated by way of non-limiting example in the accompanying drawings wherein:

25 Figure 1 is a perspective view of the framework;

Figure 2 is a view similar to the above, cutaway and with a slab of plasterboard associated;

Figure 3 is a cross-section along the line III-III in Figure 1;

Figure 4 is a view of a detail of Figure 2 in which the positioning of
30 the centering bracket is highlighted.

In the embodiments illustrated, individual characteristics shown in relation to specific examples may in reality be interchanged with other, different characteristics, existing in other embodiments.

Moreover, it should be noted that anything found to be already known
5 during the patenting process is understood not to be claimed and to be the subject of a disclaimer.

With reference to the figures, the reference numeral 1 generally designates a framework for walls or slabs 2 made of plasterboard, which comprises a plurality of vertical or horizontal profiled elements 3, a front
10 upright member 4, and a rear upright member 5, which are connected by horizontal crossmembers 6.

The framework 1 is furthermore constituted by a first element 7 adapted to act as an upper lintel for such front and rear upright members 4 and 5 and also by a rail/guide for sliding trolleys (not shown) for supporting
15 a door (not shown).

Such a first element 7 is, in a transverse cross-section, essentially C-shaped so as to define a flat back 8, which is provided with one or more longitudinal reinforcement humps or ribs 9, from the ends of which a pair of wings 10a and 10b branch off with a first wing 11a and 11b, perpendicular
20 to the back 8, and a second wing 12a and 12b, parallel to the back 8 but of shorter length overall so as to allow the definition of an opening 13 adapted to allow the positioning of the wheels of the trolley in the first element 7.

Part of the second wings 12a and 12b abuts against an end of the underlying front upright member 4, the end of a vertical profiled element 3
25 placed in front of the front upright member 4 so as to define the space 14 for the door, and the ends of an additional vertical profile 3 which is connected to a horizontal crossmember 6.

The first element 7 thus has a length approximately equal to double the width of the door.

30 The framework is further constituted by brackets 15 for centering an

upper framework 16 and for support for plasterboard slabs 2.

Each bracket 15 is essentially L-shaped so as to define a first appendage 17, which supports a lower edge of a slab or wall 2 made of plasterboard and which abuts against an underlying plug 18, and a second
5 appendage 19 against which the slab or wall 2 abuts.

Between the first and second appendages 17 and 19 there is a recess 20, facing in the direction opposite to the wall or slab 2, which has a depth that is such as to allow the insertion, for each pair of brackets 15 arranged facing each other, of the first element 7.

10 The locking between the recess 20 of each bracket 15 and the first wings 11a and 11b of the first element 7 is made possible by adapted screws 21.

The upper framework 16 has a width equal to the distance between the second appendages 19 and the brackets 15 and abuts against the back 8
15 of the first element 7.

The use of the first element 7 and of the brackets 15 makes it possible to obtain a framework where, with two individual elements, the following are simultaneously obtained: the function of upper lintel for front and rear upright members, that of rail/guide for the sliding trolleys for supporting a
20 door, and that of centering for an upper framework and the support for the plasterboard walls or slabs.

Thus it has been found that the invention fully achieves the intended aim and objects, a framework being devised which can be used for walls or slabs made of plasterboard, which offers a considerable simplicity of
25 construction and of installation and at the same time an excellent functionality and strength.

The framework furthermore can be installed even by people with no special training and is low-cost.

The invention is susceptible of numerous modifications and
30 variations, all of which are within the scope of the appended claims.

The materials used as well as the dimensions of the individual components of the invention may be more pertinent to specific requirements.

The various means of achieving certain different functions certainly
5 need not coexist only in the embodiment shown, but may be present in many embodiments, even if they are not shown. The characteristics indicated above as advantageous, convenient or the like, may also be missing or substituted by equivalent characteristics.

The disclosures in Italian Utility Model Application No.
10 TV2012U000057 from which this application claims priority are incorporated herein by reference.

Where technical features mentioned in any claim are followed by reference signs, those reference signs have been included for the sole purpose of increasing the intelligibility of the claims and accordingly, such
15 reference signs do not have any limiting effect on the interpretation of each element identified by way of example by such reference signs.

CLAIMS

1. A framework (1) for walls or slabs (2) made of plasterboard, which comprises a plurality of vertical or horizontal profiled elements (3), a front upright member (4), and a rear upright member (5), which are connected by
5 horizontal crossmembers (6), characterized in that it is constituted by a first element (7) adapted to act as an upper lintel for said front upright member (4) and said rear upright member (5) and also by a rail/guide for sliding trolleys for supporting a door, said framework (1) being further constituted by brackets (15) for centering an upper framework and for support for said
10 walls or slabs (2) made of plasterboard.

2. The framework according to claim 1, characterized in that said first element (7) is, in a transverse cross-section, essentially C-shaped so as to define a flat back (8), which is provided with one or more longitudinal reinforcement humps or ribs (9), from the ends of which a pair of wings
15 (10a, 10b) branch off with a first wing (11a, 11b), perpendicular to said back (8), and a second wing (12a, 12b), parallel to said back (8) but of shorter length overall so as to allow the definition of an opening (13) adapted to allow the positioning of the wheels of said trolley in said first element (7).

3. The framework (1) according to claims 1 or 2, characterized in that
20 part of said second wings (12a, 12b) abuts against an end of said, underlying, front upright member (4), the end of one of said vertical profiled elements (3) placed in front of said front upright member (4) so as to define the space (14) for the door, and the ends of an additional vertical profile (3) connected to a horizontal crossmember (6).

25 4. The framework (1) according to claims 1 or 3, characterized in that said first element (7) has a length approximately equal to double the width of said door.

5. The framework (1) according to claims 1 or 3, characterized in that
each one of said brackets (15) for centering an upper framework (16) and
30 for support for said slabs (2) of plasterboard is essentially L-shaped so as to

define a first appendage (17), which supports a lower edge of a slab or wall (2) made of plasterboard and which abuts against an underlying plug (18), and a second appendage (19) against which the slab or wall (2) abuts.

6. The framework (1) according to claims 1 or 5, characterized in that
5 between said first and second appendages (17, 19) there is a recess (20), facing in the direction opposite to said wall or slab (2), which has a depth that is such as to allow the insertion, for each pair of said brackets (15) arranged facing each other, of said first element (7).

7. The framework (1) according to claims 1 or 6, characterized in that
10 the locking between said recess (20) of each bracket (15) and said first wings (11a, 11b) of said first element (7) is made possible by adapted screws (21).

8. The framework (1) according to claims 1 or 7, characterized in that
15 said upper framework (16) has a width equal to the distance between said second appendages (19) and said brackets (15) and abuts against said back (8) of said first element (7).

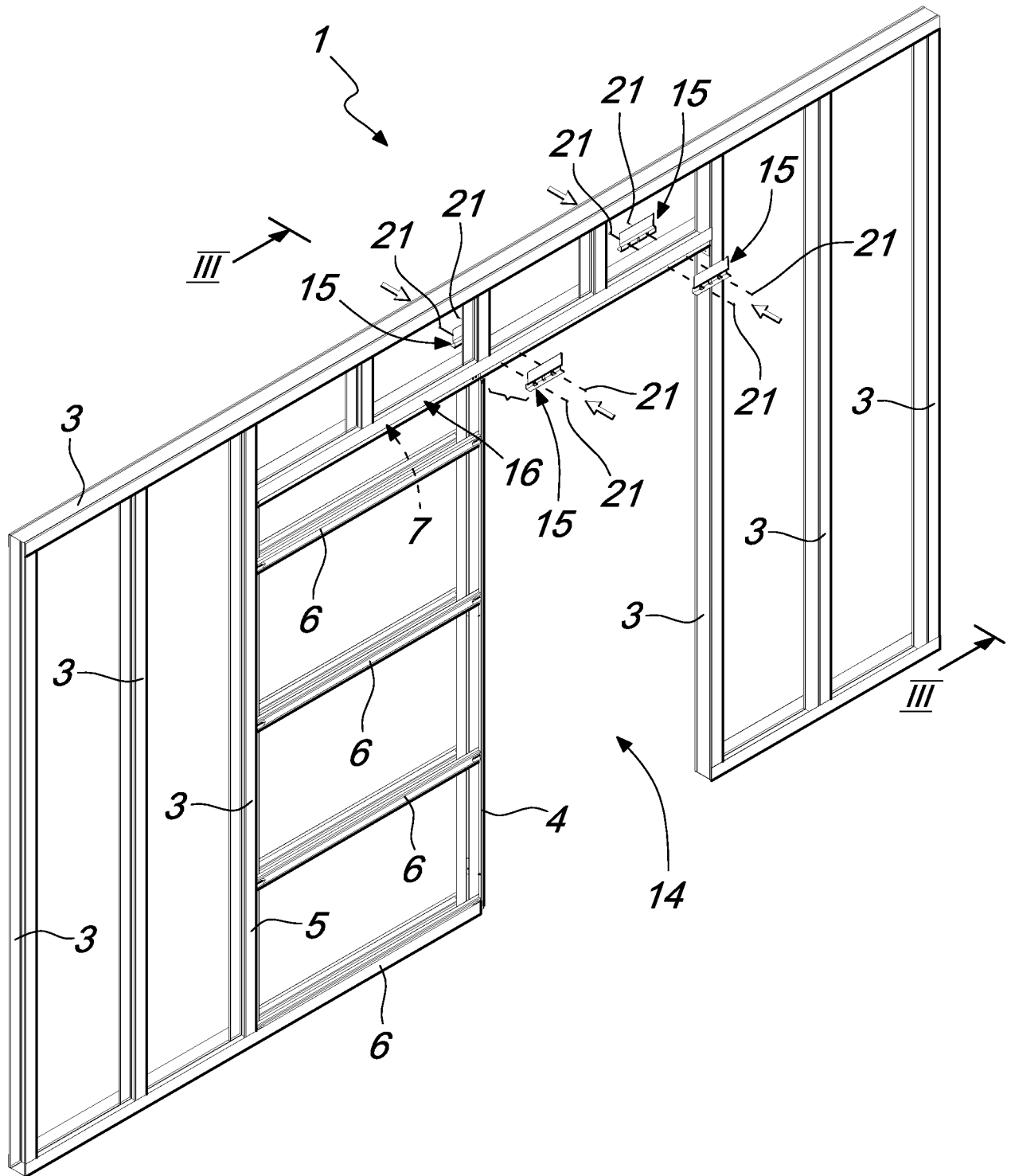

Fig. 1

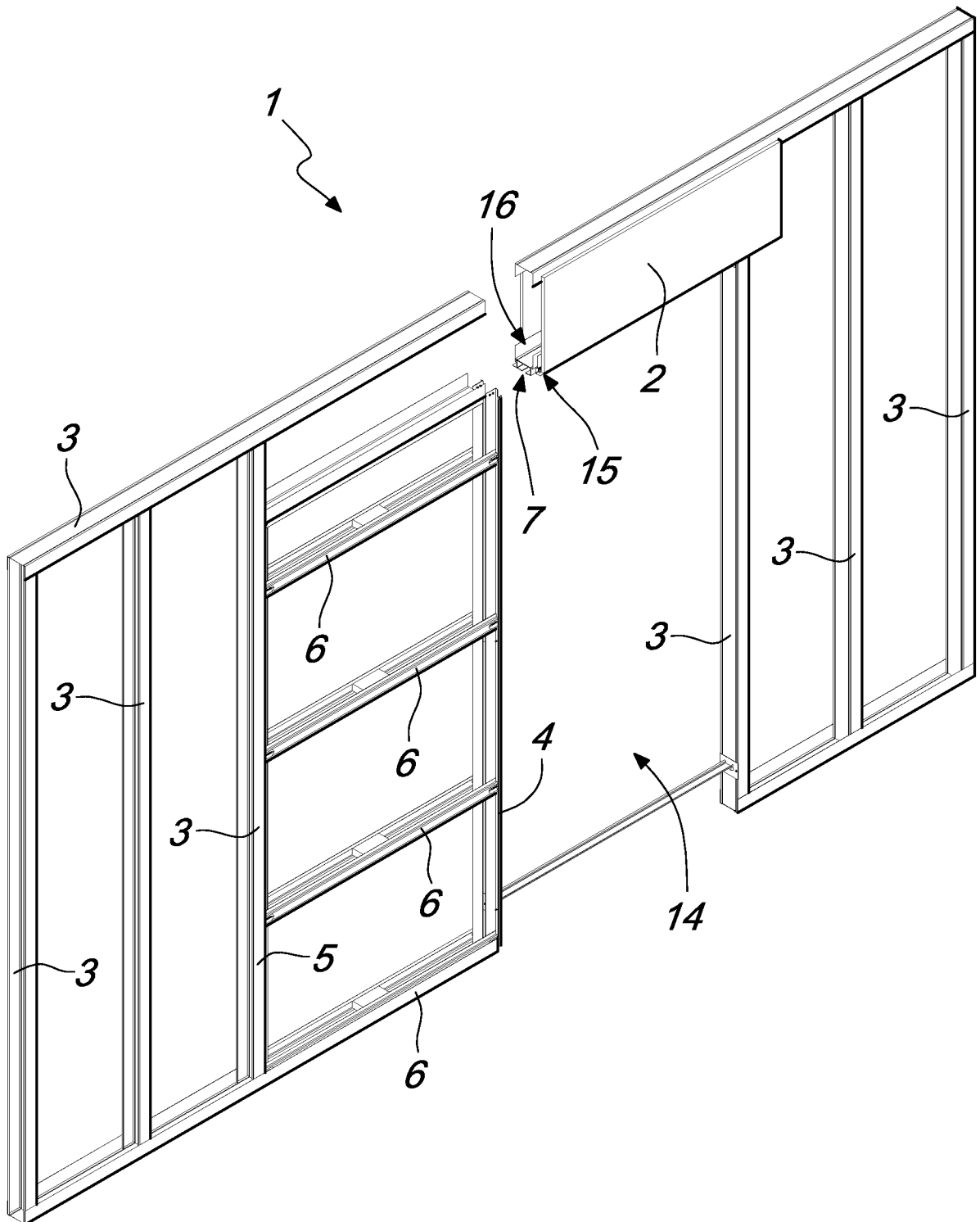

Fig. 2

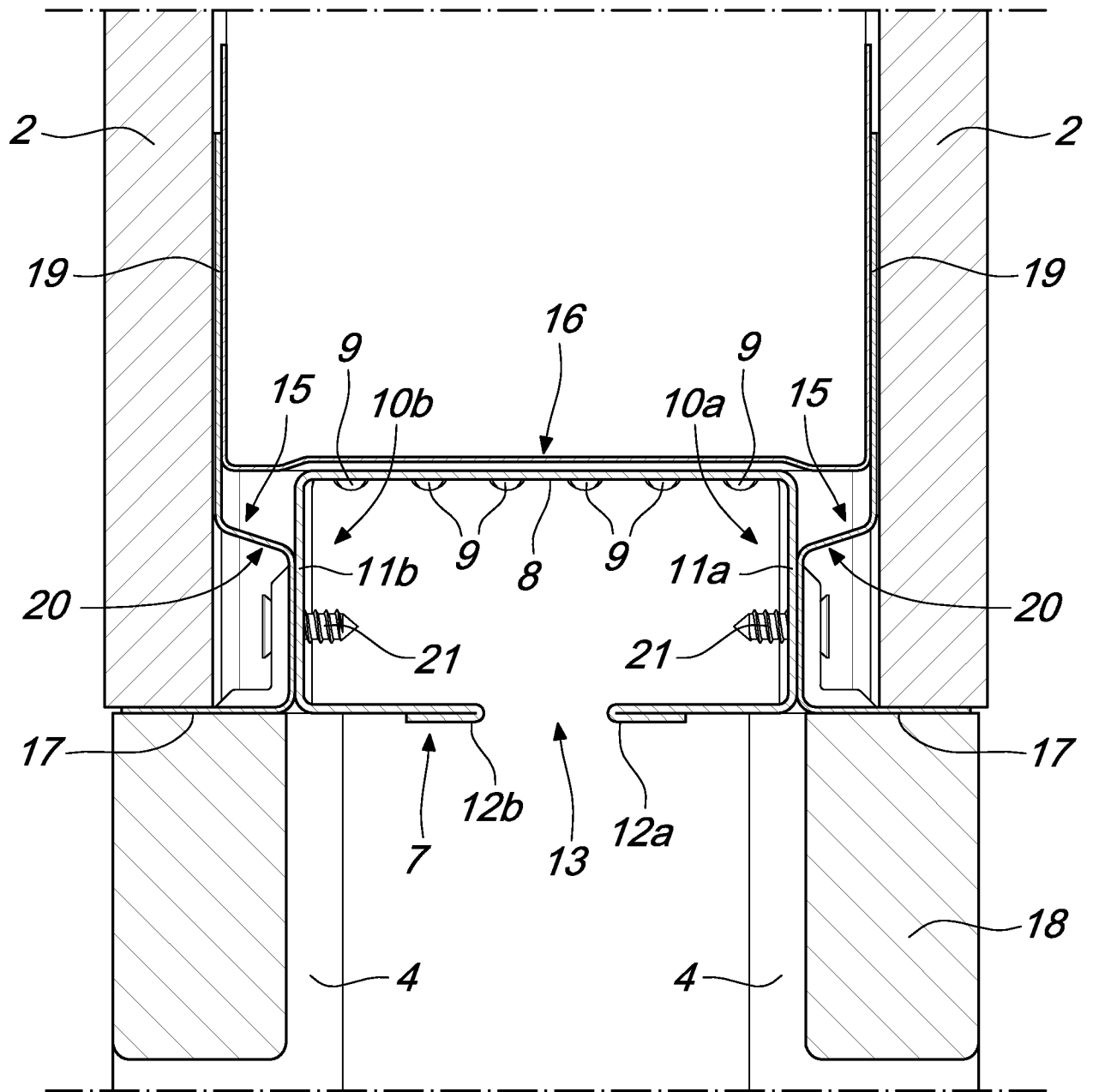

Fig. 3

INTERNATIONAL SEARCH REPORT

International application No
PCT/EP2013/069708

A. CLASSIFICATION OF SUBJECT MATTER
INV. E06B3/46
ADD.

According to International Patent Classification (IPC) or to both national classification and IPC

B. FIELDS SEARCHED
Minimum documentation searched (classification system followed by classification symbols)
E06B

Documentation searched other than minimum documentation to the extent that such documents are included in the fields searched

Electronic data base consulted during the international search (name of data base and, where practicable, search terms used)
EPO-Internal, WPI Data

C. DOCUMENTS CONSIDERED TO BE RELEVANT		
Category*	Citation of document, with indication, where appropriate, of the relevant passages	Relevant to claim No.
X A	US 3 480 989 A (EDEUS JAMES A) 2 December 1969 (1969-12-02) column 2, line 58 - column 5, line 63; figures 1-4,7	1-5 6
X A	US 2006/010774 A1 (PETERSON JIM [US]) 19 January 2006 (2006-01-19) pages 1,2,15,2, paragraphs 41-50,57	1-5 6

Further documents are listed in the continuation of Box C.

See patent family annex.

* Special categories of cited documents :

- "A" document defining the general state of the art which is not considered to be of particular relevance
- "E" earlier application or patent but published on or after the international filing date
- "L" document which may throw doubts on priority claim(s) or which is cited to establish the publication date of another citation or other special reason (as specified)
- "O" document referring to an oral disclosure, use, exhibition or other means
- "P" document published prior to the international filing date but later than the priority date claimed

- "T" later document published after the international filing date or priority date and not in conflict with the application but cited to understand the principle or theory underlying the invention
- "X" document of particular relevance; the claimed invention cannot be considered novel or cannot be considered to involve an inventive step when the document is taken alone
- "Y" document of particular relevance; the claimed invention cannot be considered to involve an inventive step when the document is combined with one or more other such documents, such combination being obvious to a person skilled in the art
- "&" document member of the same patent family

Date of the actual completion of the international search 29 October 2013	Date of mailing of the international search report 06/11/2013
Name and mailing address of the ISA/ European Patent Office, P.B. 5818 Patentlaan 2 NL - 2280 HV Rijswijk Tel. (+31-70) 340-2040, Fax: (+31-70) 340-3016	Authorized officer Hellberg, Jan

INTERNATIONAL SEARCH REPORT

Information on patent family members

International application No

PCT/EP2013/069708

Patent document cited in search report	Publication date	Patent family member(s)	Publication date
US 3480989	A	NONE	
US 2006010774	A1	NONE	