

(19)



Europäisches Patentamt

European Patent Office

Office européen des brevets



(11)

EP 0 607 533 B1

(12)

EUROPEAN PATENT SPECIFICATION

(45) Date of publication and mention
of the grant of the patent:
12.03.1997 Bulletin 1997/11

(51) Int. Cl.⁶: **B41J 2/345**

(21) Application number: **93118920.3**

(22) Date of filing: **27.07.1990**

(54) **Thermal head**

Thermischer Kopf

Tête thermique

(84) Designated Contracting States:
DE FR GB

(30) Priority: **28.07.1989 JP 195686/89**
19.03.1990 JP 66954/90

(43) Date of publication of application:
27.07.1994 Bulletin 1994/30

(62) Document number(s) of the earlier application(s) in
accordance with Art. 76 EPC:
90114494.9 / 0 410 486

(73) Proprietor: **KABUSHIKI KAISHA TOSHIBA**
Kawasaki-shi, Kanagawa-ken 210 (JP)

(72) Inventors:
• **Inoue, Nobuhiro,**
c/o Intellectual Property Div.
Minato-ku, Tokyo 105 (JP)

- **Sasaki, Katsunari,**
c/o Intellectual Property Div.
Minato-ku, Tokyo 105 (JP)
- **Nose, Toshiro,**
c/o Intellectual Property Div.
Minato-ku, Tokyo 105 (JP)
- **Hatate, Yoshio,**
c/o Intellectual Property Div.
Minato-ku, Tokyo 105 (JP)

(74) Representative: **Henkel, Feiler, Hänzel & Partner**
Möhlstrasse 37
81675 München (DE)

(56) References cited:
EP-A- 0 037 664 **US-A- 4 698 643**

EP 0 607 533 B1

Note: Within nine months from the publication of the mention of the grant of the European patent, any person may give notice to the European Patent Office of opposition to the European patent granted. Notice of opposition shall be filed in a written reasoned statement. It shall not be deemed to have been filed until the opposition fee has been paid. (Art. 99(1) European Patent Convention).

Description

The present invention relates to a thermal head, and more particularly, to a thermal head capable of half-tone printing and comprising the features of the preamble of claim 1.

5 Thermal heads with a novel faculty have been intensively developed of late such that half-tone printing can be effected by changing the size of printing dots to be printed. Such thermal heads are disclosed in "Half Tone Wax Transfer Using a Novel Thermal Head", THE FOURTH INTERNATIONAL CONGRESS ON ADVANCES IN NON-IMPACT PRINTING TECHNOLOGIES pp. 273-276, "Thermo-Convergent Ink-Transfer Printing (TCIP) for Full Color Reproduction", Proceedings of 2nd Non-impact Printing Technologies Symposium pp. 105-108, "Published Unexamined Japanese Patent Application Nos. 60-58877 and 60-78768". Each of the thermal heads is provided with a number of heating resistors each having a narrow-width portion. Electric current flowing through each heating resistor increases its density at the narrow-width portion, so that heat is produced from a local region in the high-density portion. In thermal heads, only those regions which produce heat higher than a certain value are effective for printing, and the regions capable of generating sufficient heat for the printing spread in proportion to voltage applied to the heating resistors. If higher voltage is applied to the heating resistors, therefore, the size of the printing dots increases in proportion.

15 In the conventional thermal head of this type, however, the heating resistors have a complicated configuration, so that manufacturing them requires much time and labor, and it is difficult to provide uniform properties for the numerous heating resistors.

20 Another prior art thermal printing head of the serial type is disclosed in US-A-4 698 643. In this known thermal printing head a plurality of heat generating elements are arranged on a substrate on a line oblique to the scanning direction of the thermal head. In one embodiment the heat generating elements can have the shape of a parallelogram. In this prior art printing head, however, the arrangement of the heat-generating elements is chosen in order to avoid mutual thermal influences of the elements.

25 It is the object of the present invention to provide a thermal head of a simple construction capable of satisfactory half-tone printing.

According to the invention there is provided a line-type thermal head with a main scanning axis, comprising a substrate and a plurality of heating elements arranged on the substrate along the main scanning axis, each heating element including a first parallelogrammatic resistor which has first and second pairs of opposite sides, and supply means for supplying electric current to the resistor so that the resistor generates heat, the supply means including lead electrodes connected electrically to the first opposite sides of the resistor, characterized in that a ratio of a length (L_b) of the second opposite sides to that (L_a) of the first opposite sides is not greater than 1.5, and an acute angle of the resistor, which is formed by two adjacent (i.e. the first and second) sides of the resistor, is not greater than 45° .

Preferred embodiments of the thermal head of the invention are described in the subclaims.

35 This invention can be more fully understood from the following detailed description when taken in conjunction with the accompanying drawings, in which:

Fig. 1 is a schematic view for illustrating the configuration of a thermal head according to an embodiment of the present invention;

40 Fig. 2 is a schematic view for illustrating the current distribution and heating state in a heating resistor shown in Fig. 1;

Fig. 3 is a diagram for illustrating the boundary element method;

Fig. 4 is a diagram showing various pieces of information for specifying the shape of the heating resistor;

Figs. 5A to 5L are schematic views showing the current distribution in heating resistors of various shapes obtained by the boundary element method;

45 Figs. 6 to 11 are diagrams showing energy distribution obtained by calculation;

Figs. 12A, 12B, 13A, 13B, 14A and 14B are diagrams for illustrating variations of the recording characteristics of uniform-height heating resistors with various angles;

Figs. 15 to 26 are graphs showing the results of measurement of the recording characteristics of the heating resistors with various angles;

50 Fig. 27 shows equidensity curves representing various recording densities obtained with use of a heat-sensitive recording system;

Fig. 28 shows equidensity curves representing various recording densities obtained with use of a thermal-transfer recording system;

Fig. 29 is a diagram for illustrating the optimum conditions for the manufacture of the thermal head;

55 Fig. 30 is a schematic view showing the configuration of a thermal head according to another embodiment of the invention;

Fig. 31 is a schematic view showing the configuration of a thermal head according to still another embodiment of the invention;

Fig. 32 is a schematic view showing the configuration of a thermal head according to a further embodiment of the

invention; and

Fig. 33 is a schematic view showing the configuration of a thermal head according to a still further embodiment of the invention.

5 Preferred embodiments of a thermal head according to the present invention will now be described with reference to the accompanying drawings.

As shown in Fig. 1, a thermal head 10 comprises a plurality of parallelogrammatic heating resistors 14 formed on an insulated substrate 12 of ceramics or alumina. These heating resistors 14 are arranged at regular intervals in a straight line so that each pair of parallel opposite sides of each resistor 14 are connected individually to lead electrodes 16 and 18. These heating resistors 14 and lead electrodes 16 and 18 constitute one heating element 22 for recording one printing dot. The individual lead electrodes 16 are connected to one another, thus constituting a common electrode.

When a voltage from a variable voltage source 26 is applied between the lead electrodes 16 and 18, for example, a current flows through the heating resistors 14, so that the resistors 14 are heated. Fig. 2 shows current distribution in the resistors 14. In Fig. 2, black spots represent points of measurement, the direction of each line indicates the direction of electric current at each corresponding measurement point, and the length of the line indicates the magnitude of the current at the measurement point.

The following is a description of the current distribution in the heating resistors 14 shown in Fig. 2. Here it is supposed that the resistance values of the resistors 14 cannot be changed by heating. For example, each resistor 14 is formed of a thin film whose thickness is so small that it is negligible. Thus, the current distribution is supposed to be two-dimensional.

Based on this supposition, the current flowing through the heating resistors 14 is a steady-state current, which generates a static magnetic field. Since magnetic flux density B makes no time-based change, therefore, the following equation is obtained from the Maxwell equation:

$$25 \quad \text{rot } E = - \frac{\partial B}{\partial t} \quad (1)$$

where E is an electric field. Based on the principle of conservation of charge, moreover, we obtain

$$30 \quad \text{div } i = 0, \quad (2)$$

where i is the current density. The Ohm's law is valid for the relation between the current density i and the electric field E as follows:

$$35 \quad i = \sigma E, \quad (3)$$

where σ is electric conductivity. Substituting equation (3) into equation (2), we obtain

$$40 \quad \text{div } E = 0. \quad (4)$$

From equations (1) and (4), we recognize a certain scalar function V, and the electric field E may be given by

$$45 \quad E = -\text{grad } V. \quad (5)$$

This scalar function V is generally called as an electric potential. Substituting equation (5) into equation (4), in consideration of the two-dimensional current distribution, we obtain the following Laplace equation:

$$50 \quad \frac{\partial^2 V}{\partial x^2} + \frac{\partial^2 V}{\partial y^2} = 0 \quad (6)$$

Further, energy density e_n is given by

$$55 \quad e_n = i \cdot E = \sigma E^2. \quad (7)$$

By obtaining the electric field E by substituting the solution of equation (6) into equation (5), therefore, heating energy distribution can be obtained from equation (7).

Using the boundary element method, equation (6) will now be numerically analyzed. According to the boundary

element method, as shown in Fig. 3, the boundary of a closed system is divided into elements, which are calculated using predetermined boundary conditions so that the solutions of all the elements are obtained. Thus, the internal conditions of the system are detected. As a result, the current distribution shown in Fig. 2 is obtained.

As seen from Fig. 2, there are larger current flows in the regions nearer to the center of each heating resistor 14. The heat release value at a certain point on the resistor 14 can be represented by the product of the square of the current value at that position and the resistance value of the resistor 14. Namely, the heat release value is proportional to the square of the current value. Thus, the heat value is large at the central portion of the heating resistor 14.

Meanwhile, recording of printing dots requires a fixed amount of heat or more. If the voltage applied to the heating resistor 14 is low, therefore, the printing dots are recorded by heating within a range indicated by numeral 20a in Fig. 2. As the applied voltage is increased, the printing dots start to be recorded by heating within ranges indicated by numerals 20b and 20c.

By changing the voltage applied to the heating resistor 14, the virtual heating area can be varied as indicated by 20a, 20b and 20c in Fig. 2, for example, so that the size of the printing dots can be modulated.

The current distribution in the heating resistor 14 varies depending on the shape of the resistor, and there is a resistor shape for optimum gradation recording. This is a shape which enables heat concentration to a certain degree or higher. Parameters indicative of a parallelogrammatic shape include the ratio g between the respective lengths L_a and L_b of sides 14a and 14b and the angle θ (acute angle in this case) formed between the sides 14a and 14b, as shown in Fig. 4. The optimum shape can be obtained under the following conditions:

$$\text{ratio } g (=L_b/L_a) \leq 1,$$

$$\text{angle } \theta \leq 45^\circ.$$

The following is a description of the optimum shape of the heating resistor 14. In the example described below, the thermal head is applied to a standard-G3 facsimile.

In the standard-G3 facsimile, the resolution in the main scanning direction (arrangement direction of the heating resistors 14) is specified as being 8 dots/mm, so that the width or length L_a of each heating resistor 14 is

$$L_a \leq 125 \mu\text{m}.$$

If the gap between each two adjacent heating resistors 14 is 25 μm , L_a is

$$L_a = 100 \mu\text{m}.$$

Figs. 5A to 5L show various modes of current distribution obtained for 12 varied shapes by the aforementioned method using the outline of each heating resistor 14 as a boundary, as shown in Fig. 4, under conditions including $L_a = 100 \mu\text{m}$ and the respective electric potentials of the lead electrodes 16 and 18 at 24 V and 0V. The 12 shapes may be classified into four types based on the combinations of the ratios g of 1, 1.5, and 2 and the angles θ of 30° (type (a)), 45° (type (b)), 60° (type (c)), and 75° (type (d)).

Figs. 5A to 5C show cases corresponding to the ratios g of 1, 1.5, and 2, respectively, for type (a), and Figs. 5D to 5F, 5G to 5I, and 5J to 5L show similar cases for types (b), (c), and (d), respectively.

The electric fields E in the horizontal and diagonal directions (see Fig. 4) are obtained for the individual heating resistors 14 having these shapes. Figs. 6 to 11 show e_n/σ obtained by dividing the energy density e_n , calculated according to equation (7) on the basis of the obtained electric fields E , by the electric conductivity σ .

Figs. 6 and 7 show cases corresponding to the horizontal and diagonal directions, respectively, for the ratio g of 1, Figs. 8 and 9 show similar cases for the ratio g of 1.5, and Figs. 10 and 11 show similar cases for the ratio g of 2.

As seen from Figs. 5A to 5L and Figs. 6 to 11, the smaller the angle θ and ratio g , the more intensive the centralization of the current is. Figs. 6 to 11 indicate the following circumstances. If the ratio g is 2 (Figs. 10 and 11), the energy distribution is substantially uniform, and there is hardly any energy concentration. If the ratio g is 1.5, some energy concentration is caused. If the ratio g is 1, a considerable energy concentration is entailed. As seen from Figs. 6 and 7, moreover, if the ratio g is 1, the energy concentration is conspicuous when the angle θ is 45° or narrower.

It may be guessed from these results that the conditions for the optimum shape of each heating resistor 14 are $g \leq 1$ and $\theta \leq 45^\circ$.

The above is a theoretical description of the optimum shape of the heating resistor 14, while the following is a description based on experimental data.

In actually manufacturing the thermal head, the width (main scanning direction) and height (auxiliary scanning direction) of each heating resistor depend on the resolution to be obtained. For higher reproducibility, the resolution used for the standard-G3 facsimile, for example, is adjusted to 8 dots/mm in the main scanning direction and 15.4 lines/mm in the auxiliary scanning direction. Thus, the height h of each thermal head used in the standard-G3 facsimile

is given by

$$h \cong 1/15.4. \quad (8)$$

5 Namely, the height h is expected to be about 65 μm or more. As mentioned before, moreover, the width or length L_a of the heating resistor 14 is 100 μm .

If the width and height of the heating resistor 14 are determined in this manner, the recording characteristic depends on the angle θ . If the angle θ is relatively wide, as shown in Fig. 12A, the degree of heat concentration is low, so that the recording characteristic curve is supposed to have a sharp leading edge, as shown in Fig. 12B. If the angle
10 θ is medium, as shown in Fig. 13A, the heat concentration is conspicuous, so that the recording characteristic curve is supposed to have a gentle leading edge, as shown in Fig. 13B. If the angle θ is relatively narrow, as shown in Fig. 14A, heating resistor 14 is elongated, so that the degree of heat concentration is low, and therefore, the recording characteristic curve is supposed to have a sharp leading edge, as shown in Fig. 14B.

In half-tone printing, it is advisable to use a recording characteristic curve having a gentle leading edge. If the width and height of each heating resistor 14 are specified, therefore, the presence of the optimum angle θ can be expected.
15

Accordingly, in order to determine optimum angles for practical use, thermal heads were manufactured by way of trial, using various angles θ of 35°, 38°, 41°, 45°, 49°, and 54° in combination with $L_a = 100 \mu\text{m}$ and $h = 70 \mu\text{m}$, and the recording characteristics for the heat-sensitive recording system and thermal-transfer recording system were measured. Table 1 shows evaluation conditions for this measurement, and Figs. 15 to 26 show the results of the measurement.
20

Table 1

Item	Subitem	Contents
Heat-sensitive recording	Recording paper	TF50KS-E4(commmercially available)
	Recording paper	TRW-C2(commmercially available)
Thermal-transfer recording	Ink film	TRX-21(3.5 μm) (commercially available)
	Recording speed	5ms/line
	Way of applying recording energy	Pulse-width-fixed voltage changing method
Recording conditions	Recording pulse width	2ms/pulse
	Measurement sample	Solid black density
Method of measurement	Measurement apparatus	Macbeth densitometer

40 Figs. 15 to 20 show recording characteristic curves obtained with use of the heat-sensitive system. The curves of Figs. 15, 16, 17, 18, 19 and 20 represent the recording characteristics of thermal heads having heating resistors whose angles θ are 35°, 38°, 41°, 45°, 49°, and 54°, respectively.

Figs. 21 to 26 show recording characteristic curves obtained with use of the thermal-transfer system. The curves of Figs. 21, 22, 23, 24, 25 and 26 represent the recording characteristics of the thermal heads having the heating resistors whose angles θ are 35°, 38°, 41°, 45°, 49°, and 54°, respectively.
45

In Figs. 15 to 26, recording characteristic curves for a thermal head having rectangular heating resistors (angle $\theta = 90^\circ$) are illustrated for comparison.

Figs. 27 and 28 show 0.1-interval equidensity curves related to recording densities obtained with use of the heat-sensitive recording system and thermal-transfer recording system, respectively, and representing relationships between the energy E and angle θ .
50

An optimum angle A_n for the half-tone printing is obtained corresponding to the point at which the equidensity curves are at the widest intervals. In the heat-sensitive recording system, as seen from Fig. 27, the optimum angle A_n is 45°.

As regards the thermal-transfer recording system, on the other hand, it may be believed that essential equidensity curves free of the influences of data-dispersive factors (e.g., applied pressure, positions of heating resistors within the nip width, etc.) should be the characteristic curves indicated by broken lines in Fig. 28. The optimum angle A_n inferred from these characteristic curves of Fig. 28 is also 45°.
55

As seen from Figs. 27 and 28, moreover, the lower the recording energy, the wider the intervals between the equidensity curves are. This indicates that more gradations can be assigned with lower densities, ensuring satisfactory half-

tone printing.

As described above, the conditions for the optimum shape of each heating resistor 14 are $g \leq 1$ and $\theta \leq 45$.

In the thermal head of the present embodiment, the angle θ , height h , ratio g , and the lengths L_a and L_b of the sides 14a and 14b of each heating resistor 14 have the following relationships:

$$g = L_b/L_a, \quad (9)$$

$$h/L_b = \sin\theta. \quad (10)$$

Eliminating the length L_b by substituting equation (9) into equation (10) and regarding the length L_a as $100 \mu\text{m}$, as mentioned before, we obtain

$$h/100g = \sin\theta. \quad (11)$$

Equation (11) is illustrated in the graph of Fig. 29 in which the axes of abscissa and ordinate represent the angle θ and ratio g , respectively, and the height h is used as a parameter. In Fig. 29, the curve moves to the right as the height h increases.

The hatched region of Fig. 29 corresponds to a range in which the requirements ($g \leq 1$ and $\theta \leq 45$) and the requirement ($h \geq 65 \mu\text{m}$) provided by the standards for standard-G3 facsimiles are all fulfilled.

Thus, the conditions for the optimum shape of the heating resistors 14 of a thermal head used in a standard-G3 facsimile are $h = 70 \mu\text{m}$ and $\theta = 45^\circ$ if the width $L_a = 100 \mu\text{m}$.

Prevailing resolutions of the standard-G3 facsimiles include, for example, $8 \text{ dots/mm} \times 7.7 \text{ lines/mm}$ and $8 \text{ dots/mm} \times 3.85 \text{ lines/mm}$. These resolutions in the auxiliary scanning direction are lower than 15.4 lines/mm . Although the thermal head according to the above embodiment is suited for the case where the resolution in the auxiliary scanning direction is 15.4 lines/mm , it cannot be applied to such low-resolution recording.

Referring now to Fig. 30, a thermal head according to another embodiment of the present invention suited for low-resolution recording will be described. In Fig. 30, like reference numerals refer to members equivalent to the ones used in the foregoing embodiment, and a detailed description of those members is omitted.

The thermal head 10 comprises a large number of heating elements 22 for recording one printing dot each. These elements 22 are arranged one-dimensionally at regular intervals on an insulated substrate 12. Each heating element 22 includes two heating resistors 14 which are connected electrically to each other by means of an intermediate electrode 24 formed of high-conductivity material. The intermediate electrode 24, which is in the form of a rectangle having the same width as each heating resistor 14, connects the adjacent sides of the resistors 14. The respective other sides of the resistors 14 are connected individually to lead electrodes 16 and 18. Thus, the two heating resistors 14 are connected electrically in series with each other.

In the thermal head constructed in this manner, the two heating resistors 14 included in each heating element 22 cooperate with each other to function as one heating section, thereby recording only one printing dot. Thus, if each heating resistor 14 has the same shape as in the foregoing embodiment, that is, if the width, height, and angle are $100 \mu\text{m}$, $70 \mu\text{m}$, and 45° , respectively, the height of the heating section is about $140 \mu\text{m}$, which corresponds to 7.7 lines/mm .

At this time, although one of the heating resistors 14 is temporarily subjected to current concentration, the current is uniform in the intermediate electrode 24. Namely, the intermediate electrode 24 serves as an equipotential surface, and similar current concentration is caused in the other heating resistor 14. Thus, the heating characteristics are suited for gradation recording, and satisfactory gradation recording can be effected with the resolution of $8 \text{ dots/mm} \times 7.7 \text{ lines/mm}$.

Referring now to Fig. 31, still another embodiment of the present invention will be described. In a thermal head 10 according to this embodiment, an intermediate electrode 24 is in the shape of a parallelogram inclined at the same angle as heating resistors 14. Also, lead electrodes 16 and 18 are inclined at the same angle as the resistors 14. Thus, the heating resistors 14, intermediate electrode 24, and lead electrodes 16 and 18 are arranged in a straight line.

Accordingly, satisfactory gradation recording can be effected with the resolution of $8 \text{ dots/mm} \times 7.7 \text{ lines/mm}$ in the same manner as in the foregoing embodiments, and the following effect can be obtained. In the thermal head 10, which is manufactured by thin film formation technique, the intermediate electrode 24 and the lead electrodes 16 and 18 are formed by the photo-etching process (PEP). More specifically, the thermal head 10 is manufactured by selectively forming the intermediate electrode 24 and the lead electrodes 16 and 18 on a plurality of parallelogrammatic resistors including two heating resistors 14 in each heating element 22. Thus, when the heating resistors 14, intermediate electrode 24, and lead electrodes 16 and 18 are formed in a straight line, as in the case of the thermal head 10 of this embodiment, photo-etching masks, used to form the electrodes 16, 18 and 24, must be strictly aligned only in one direction of the array of the heating elements 22, and this operation is easy.

The respective centers of the two heating resistors 14 included in each heating element 22 are deviated in the main scanning direction (arrangement direction of the heating members 22) by α in the thermal head of Fig. 30 and by β in

the case of Fig. 31. Thus, two heating regions for forming one printing dot are deviated individually by α and β in the main scanning direction, so that the quality of some of recorded images may possibly be lowered.

Referring now to Fig. 32, a further embodiment of the present invention will be described. In this embodiment, which is arranged in consideration of these circumstances, a thermal head 10 is constructed in the same manner as the thermal head shown in Fig. 30, provided that two parallelogrammatic heating resistors 14 included in each heating element 22 are inclined in opposite directions. In this arrangement, the two heating resistors 14, used to record one printing dot, are situated on one and the same auxiliary scanning line without being deviated in the main scanning direction. Accordingly, satisfactory gradation recording can be effected with the resolution of 8 dots/mm \times 7.7 lines/mm, and improved recording can be ensured without entailing deterioration in printed image quality.

Referring now to Fig. 33, moreover, a still further embodiment of the present invention will be described. In a thermal head 10 of this embodiment, two heating resistors 14 included in each heating element 22 are arranged parallel to each other so that their respective centers are situated on one and the same auxiliary scanning line. As in the case of the thermal head shown in Fig. 32, therefore, the heating resistors 14 in the heating element 22 are situated on the same auxiliary scanning line, so that satisfactory gradation recording can be effected with the resolution of 8 dots/mm \times 7.7 lines/mm, and improved recording can be ensured without entailing deterioration in printed image quality.

It is to be understood that the present invention is not limited to the embodiments described above, and that various changes and modifications may be effected therein by one skilled in the art without departing from the scope of the invention. Although the thermal heads according to the embodiments described above are applied to standard-G3 facsimiles, for example, they may be naturally applied also to any other suitable apparatuses. Thus, the heating resistors are not restricted to the conditions including the width $L_a = 100 \mu\text{m}$, height $h = 70 \mu\text{m}$, and angle $\theta = 45^\circ$. In the above embodiments, moreover, each heating element includes two heating resistors to provide the resolution of 8 dots/mm \times 7.7 lines/mm. Alternatively, however, four heating resistors may be used in each heating element to obtain a resolution of 8 dots/mm \times 3.85 lines/mm. Further, any desired resolution may be obtained by suitably changing the number of heating resistors in each heating element. In addition, though printing-dots are changed in size by applying various voltages to the resistor in the above embodiments, they may be changed by varying time for supplying electric current to the resistor.

Claims

1. A thermal head (10) of a line-type having a main scanning axis, comprising a substrate (12) and a plurality of heating elements (22) arranged on the substrate (12) along the main scanning axis, each heating element (22) including a first parallelogrammatic resistor (14) which have first and second pairs of opposite sides (14a, 14b), and supply means (16, 18, 26) for supplying electric current to the resistor (14) so that the resistor generates heat, the supply means (16, 18, 26) including lead electrodes (16, 18) connected electrically to the first opposite sides of the resistor (14), characterized in that a ratio of a length (L_b) of the second opposite sides (14b) to that (L_a) of the first opposite sides (14a) is not greater than 1.5, and an acute angle of the resistor, which is formed by two adjacent, i.e. the first and second, sides (14a, 14b) of the resistor, is not greater than 45° .
2. The thermal head (10) according to claim 1, characterized in that each heating element (22) further includes a second parallelogrammatic resistor (14) which has the same shape and size as the first resistor (14) and is arranged with the first opposite sides (14a) thereof in parallel to those of the first resistor, and an intermediate electrode (24) electrically connecting the facing sides of the first opposite sides (14a) of the first and second resistors (14), and the lead electrodes are electrically connected to the outer sides of the first opposite sides (14a) of the first and second resistors (14) such that the first and second resistors (14) are connected electrically in series through the intermediate electrode (24).
3. The thermal head (10) according to claim 2, characterized in that the first and second resistors (14) are linearly symmetrical with each other.
4. The thermal head (10) according to claim 3, characterized in that the first and second resistors (14) are aligned along an axis perpendicular to the main scanning axis.
5. The thermal head (10) according to claim 1, characterized in that the lead electrodes (16, 18) have parallel sides at an end, the parallel sides being aligned with the second opposite sides (14b) of the resistor.
6. The thermal head (10) according to claim 2, characterized in that the intermediate electrode is a parallelogram, a pair of opposite sides of which are connected to the first sides (14a) of the first and second resistors, and the other pair of opposite sides of which are aligned with the second sides (14b) of the first and second resistors.

7. The thermal head (10) according to claim 6, characterized in that the lead electrodes (16, 18) have parallel sides at an end, the parallel sides being aligned with the second opposite sides (14b) of the first and second resistors.
8. The thermal head (10) according to claim 5, 6 or 7, characterized in that the first opposite sides (14a) of first resistors (14) of all of the heating elements are aligned.
9. The thermal head (10) according to claim 8, characterized in that the second opposite sides (14b) of second resistors (14) of all of the heating elements are aligned.

10 **Patentansprüche**

1. Ein Wärmekopf bzw. thermischer Kopf (10) vom Zeilentyp mit einer Haupt-Abtastachse, umfassend einen Träger (12) und mehrere Heizelemente (22), die entlang der Haupt-Abtastachse auf dem Träger (12) angeordnet sind, wobei jedes Heizelement (22) ein erstes parallelogrammförmiges Widerstandselement (14), das erste und zweite Paare gegenüberliegender Seiten (14a, 14b) aufweist, und Versorgungsmittel (16, 18, 26) zum Zuführen von elektrischem Strom zum Widerstandselement (14) um dieses Wärme erzeugen zu lassen, umfaßt, wobei die Versorgungsmittel (16, 18, 26) Leitungs- bzw. Anschluß-Elektroden (16, 18) umfassen, die elektrisch leitend mit den ersten gegenüberliegenden Seiten des Widerstandselements (14) verbunden sind, dadurch gekennzeichnet, daß ein Verhältnis einer Länge (L_b) der zweiten gegenüberliegenden Seiten (14b) zu der Länge (L_a) der ersten gegenüberliegenden Seiten (14a) nicht größer als 1,5 ist und daß ein durch zwei benachbarte, d.h. die ersten und zweiten Seiten (14a, 14b) des Widerstandselements gebildeter spitzer Winkel nicht größer als 45° ist.
2. Der Wärmekopf (10) gemäß Anspruch 1, dadurch gekennzeichnet, daß jedes Heizelement (22) desweiteren ein zweites parallelogrammförmiges Widerstandselement (14), das die gleiche Form und Größe wie das erste Widerstandselement (14) besitzt und mit seinen ersten gegenüberliegenden Seiten (14a) parallel zu denen des ersten Widerstandselements (14) angeordnet ist, sowie eine Zwischenelektrode (24) aufweist, die die einander zugewandten Seiten der ersten gegenüberliegenden Seiten (14a) der ersten und zweiten Widerstandselemente (14) elektrisch leitend verbindet, und daß die Leitungs-Elektroden elektrisch leitend mit den äußeren Seiten der ersten gegenüberliegenden Seiten (14a) der ersten und zweiten Widerstandselemente (14) verbunden sind, derart, daß die ersten und zweiten Widerstandselemente (14) über die Zwischenelektrode (24) elektrisch in Reihe geschaltet sind.
3. Der Wärmekopf (10) gemäß Anspruch 2, dadurch gekennzeichnet, daß die ersten und zweiten Widerstandselemente (14) linear-symmetrisch zueinander sind.
4. Der Wärmekopf (10) gemäß Anspruch 3, dadurch gekennzeichnet, daß die ersten und zweiten Widerstandselemente (14) entlang einer senkrecht zur Haupt-Abtastachse verlaufenden Achse ausgerichtet sind.
5. Der Wärmekopf (10) gemäß Anspruch 1, dadurch gekennzeichnet, daß die Leitungs- bzw. Anschluß-Elektroden (16, 18) an einem Ende parallele Seiten aufweisen, die mit den zweiten gegenüberliegenden Seiten (14b) des Widerstandselements ausgerichtet sind.
6. Der Wärmekopf (10) gemäß Anspruch 2, dadurch gekennzeichnet, daß die Zwischenelektrode ein Parallelogramm darstellt, wobei ein Paar der gegenüberliegenden Seiten (des Parallelogramms) mit den ersten Seiten (14a) der ersten und zweiten Widerstandselemente verbunden sind und das andere Paar der gegenüberliegenden Seiten (des Parallelogramms) mit den zweiten Seiten (14b) der ersten und zweiten Widerstandselemente ausgerichtet sind.
7. Der Wärmekopf (10) gemäß Anspruch 6, dadurch gekennzeichnet, daß die Leitungs- bzw. Anschluß-Elektroden (16, 18) an einem Ende parallele Seiten aufweisen, die mit den zweiten gegenüberliegenden Seiten (14b) der ersten und zweiten Widerstandselemente ausgerichtet sind.
8. Der Wärmekopf (10) gemäß Anspruch 5, 6 oder 7, dadurch gekennzeichnet, daß die ersten gegenüberliegenden Seiten (14a) der ersten Widerstandselemente (14) aller Heizelemente ausgerichtet sind.
9. Der Wärmekopf (10) gemäß Anspruch 8, dadurch gekennzeichnet, daß die zweiten gegenüberliegenden Seiten (14b) der zweiten Widerstandselemente (14) aller Heizelemente ausgerichtet sind.

Revendications

- 5 1. Tête thermique (10) du type en ligne, ayant un axe de balayage principal, comprenant un substrat (12) et plusieurs éléments chauffants (22) disposés sur le substrat (12) suivant l'axe de balayage principal, chaque élément chauffant (22) incluant une première résistance en forme de parallélogramme (14) qui a des premières et secondes paires de côtés opposés (14a, 14b), et un moyen d'alimentation (16, 18, 26) pour fournir du courant électrique à la résistance (14) pour que la résistance produise de la chaleur, le moyen d'alimentation (16, 18, 26) incluant des électrodes conductrices (16, 18) connectées électriquement aux premiers côtés opposés de la résistance (14), caractérisée en ce que:
- 10 le rapport de la longueur (Lb) des seconds côtés opposés (14b) à celle (La) des premiers côtés opposés (14a) n'est pas supérieur à 1,5, et en ce qu'un angle aigu de la résistance, qui est formé par deux côtés adjacents, c'est-à-dire, le premier et le second côtés, (14a, 14b) de la résistance, n'est pas supérieur à 45°
- 15 2. Tête thermique (10) selon la revendication 1, caractérisée en ce que chaque élément chauffant (22) comprend, en outre, une seconde résistance en forme de parallélogramme (14) qui a les mêmes forme et taille que la première résistance (14) et qui est disposée avec ses premiers côtés opposés (14a) parallèles à ceux de la première résistance, et une électrode intermédiaire (24) reliant électriquement les côtés qui se font face des premiers côtés opposés (14a) des première et seconde résistances (14), et en ce que les électrodes conductrices sont connectées électriquement aux côtés extérieurs des premiers côtés opposés (14a) des première et seconde résistances (14) de façon telle que les première et seconde résistances (14) soient connectées électriquement en série par l'intermédiaire de l'électrode intermédiaire (24).
- 20 3. Tête thermique (10) selon la revendication 2, caractérisée en ce que les première et seconde résistances (14) sont, l'une par rapport à l'autre, symétriques par rapport à une droite.
- 25 4. Tête thermique (10) selon la revendication 3, caractérisée en ce que les première et seconde résistances (14) sont alignées suivant un axe perpendiculaire à l'axe de balayage principal.
- 30 5. Tête thermique (10) selon la revendication 1, caractérisée en ce que les électrodes conductrices (16, 18) ont des côtés parallèles à une extrémité, les côtés parallèles étant alignés avec les seconds côtés opposés (14b) de la résistance.
- 35 6. Tête thermique (10) selon la revendication 2, caractérisée en ce que l'électrode intermédiaire est un parallélogramme, dont une paire de côtés opposés est connectée aux premiers côtés (14a) des première et seconde résistances, et dont l'autre paire de côtés opposés est alignée avec les seconds côtés (14b) des première et seconde résistances.
- 40 7. Tête thermique (10) selon la revendication 6, caractérisée en ce que les électrodes conductrices (16, 18) ont des côtés parallèles à une extrémité, les côtés parallèles étant alignés avec les seconds côtés opposés (14b) des première et seconde résistances.
8. Tête thermique (10) selon la revendication 5, 6, ou 7, caractérisée en ce que les premiers côtés opposés (14a) des premières résistances (14) de tous les éléments chauffants sont alignés.
- 45 9. Tête thermique (10) selon la revendication 8, caractérisée en ce que les seconds côtés opposés (14b) des secondes résistances (14) de tous les éléments chauffants sont alignés.

50

55

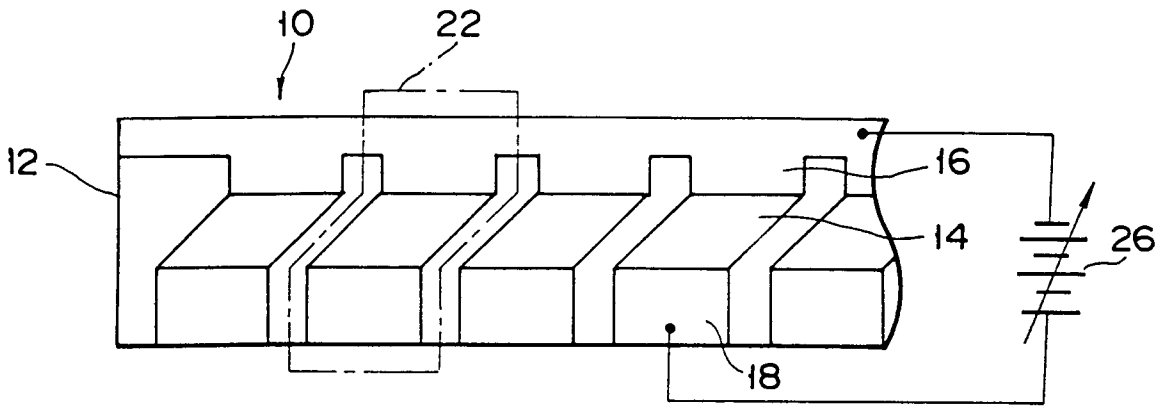

FIG. 1

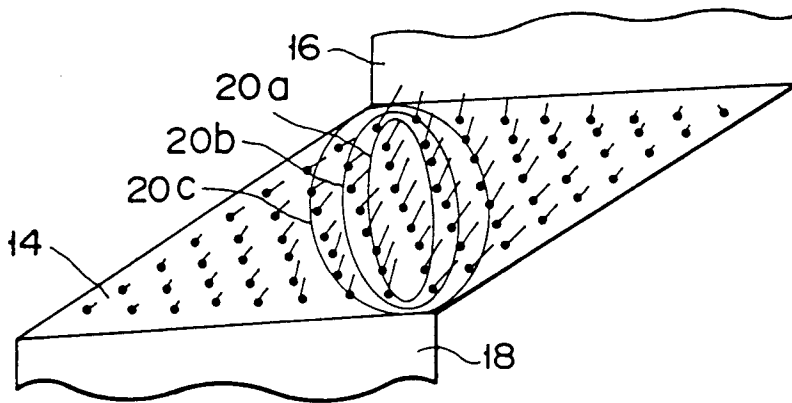

FIG. 2

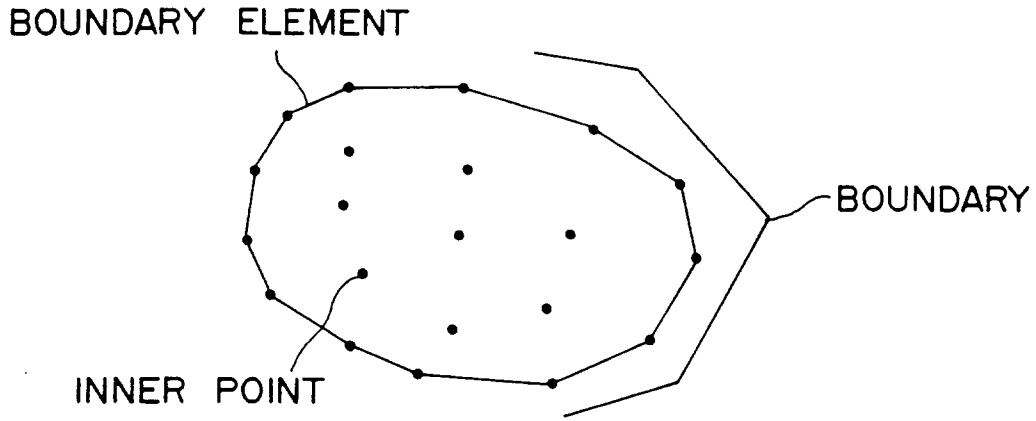

FIG. 3

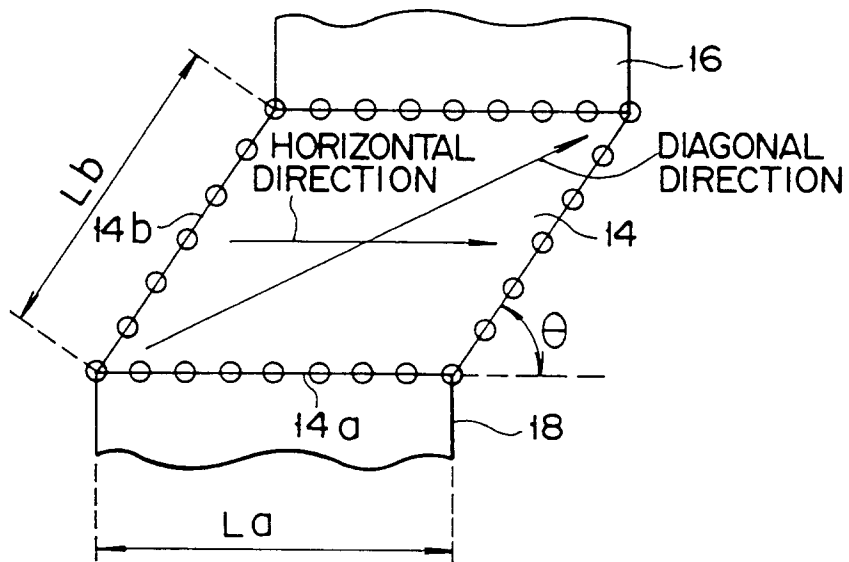

FIG. 4

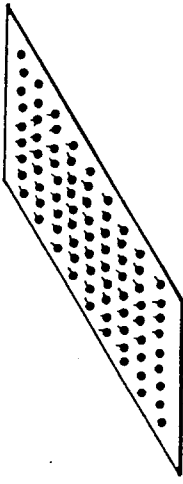

FIG. 5A

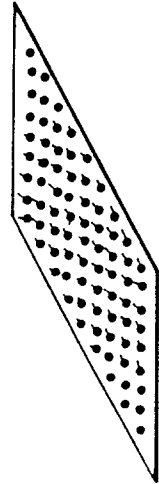

FIG. 5B

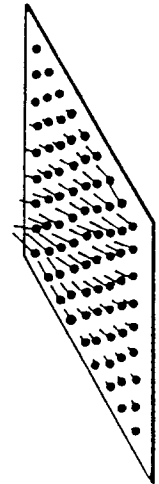

FIG. 5C

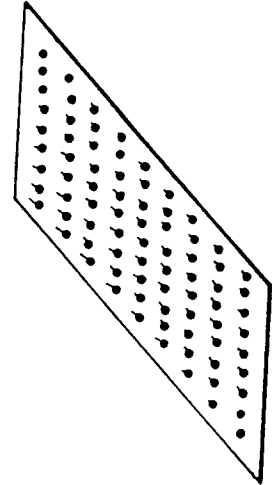

FIG. 5D

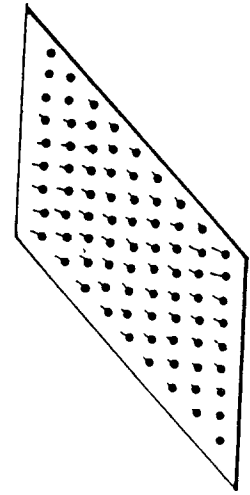

FIG. 5E

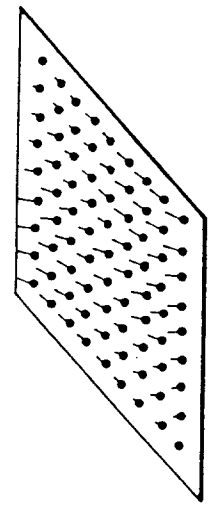

FIG. 5F

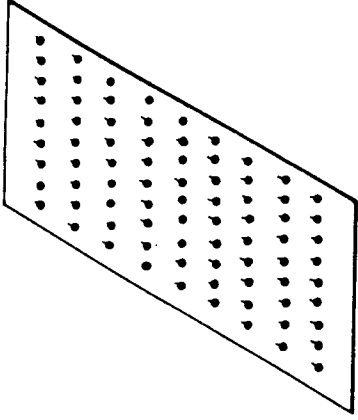

FIG. 5I

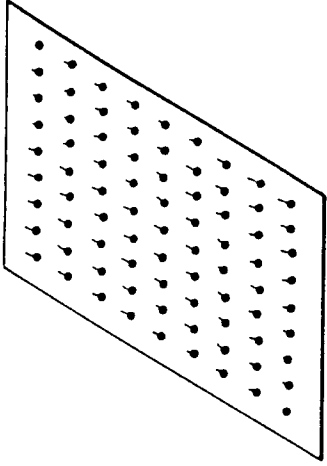

FIG. 5H

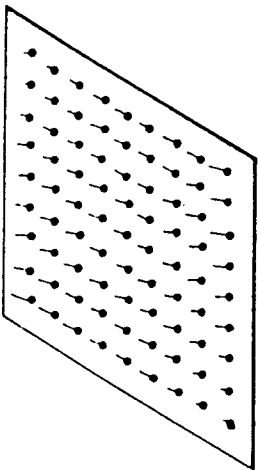

FIG. 5G

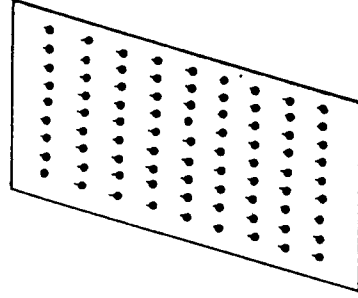

FIG. 5L

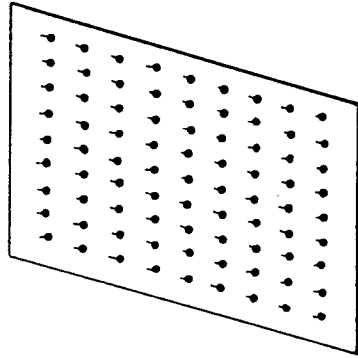

FIG. 5K

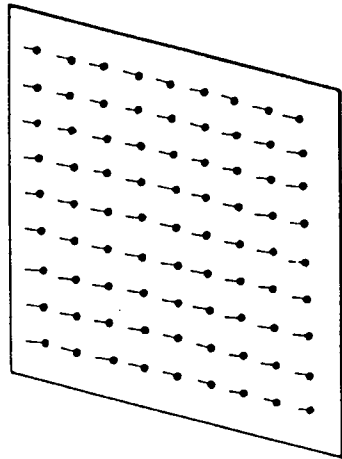

FIG. 5J

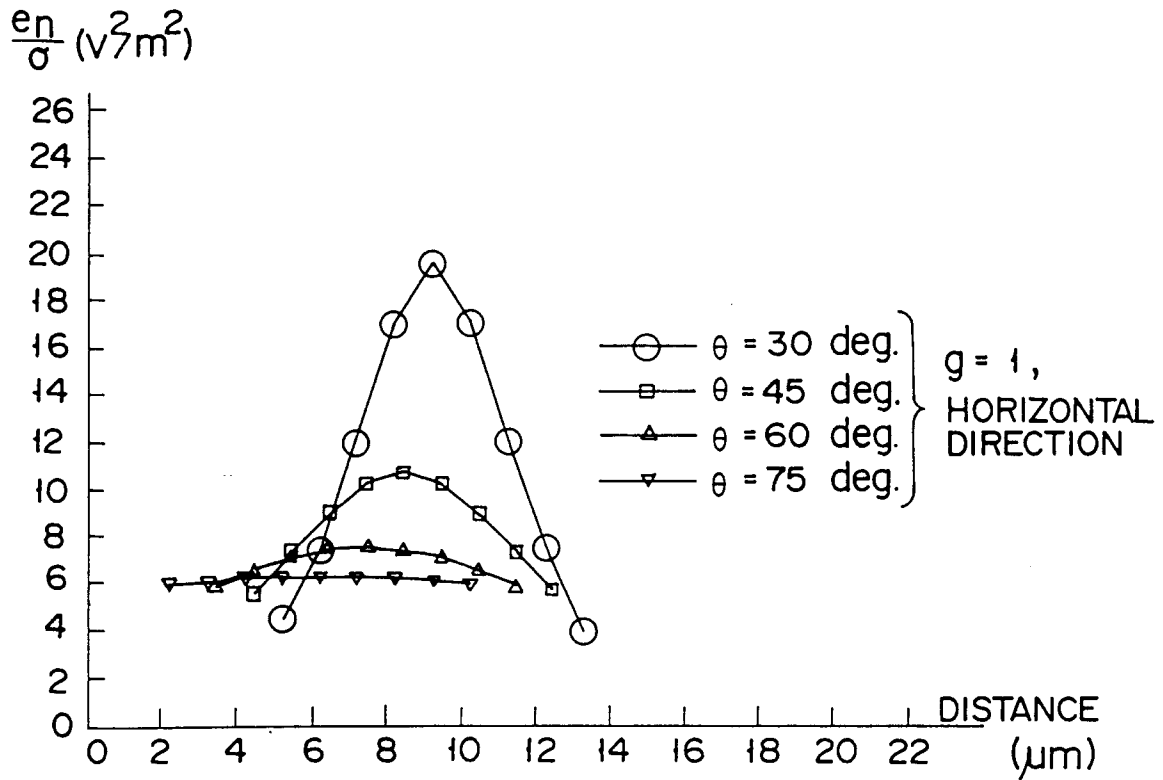

FIG. 6

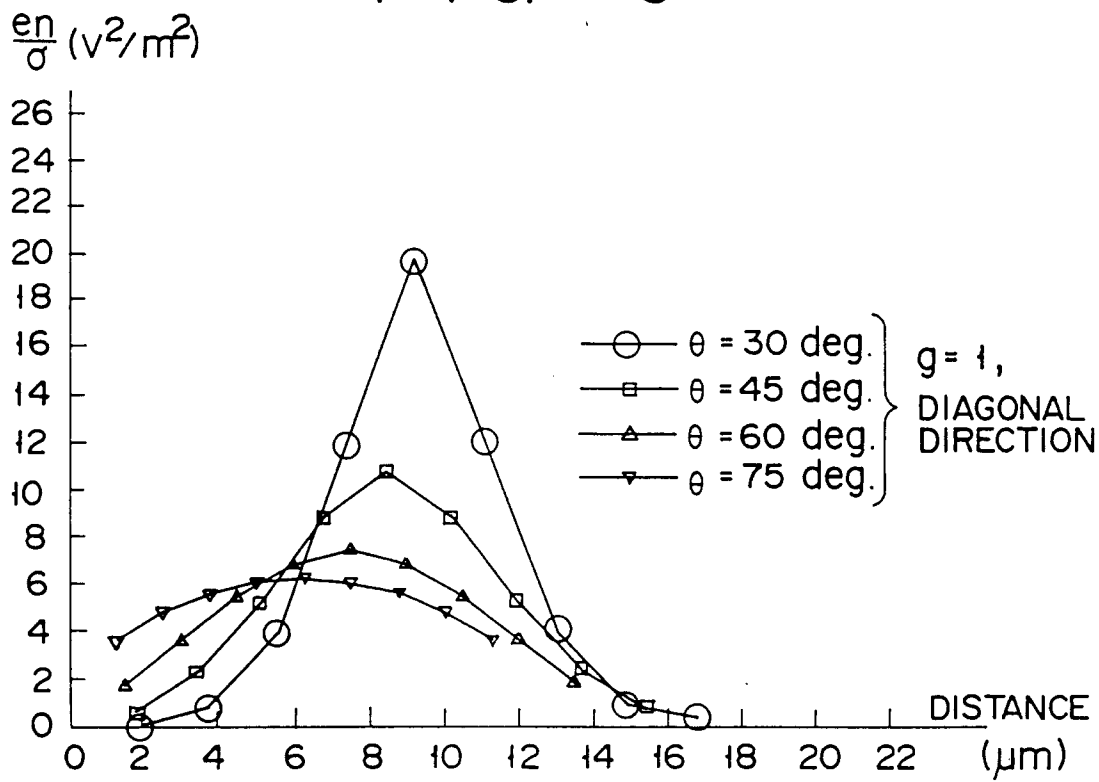

FIG. 7

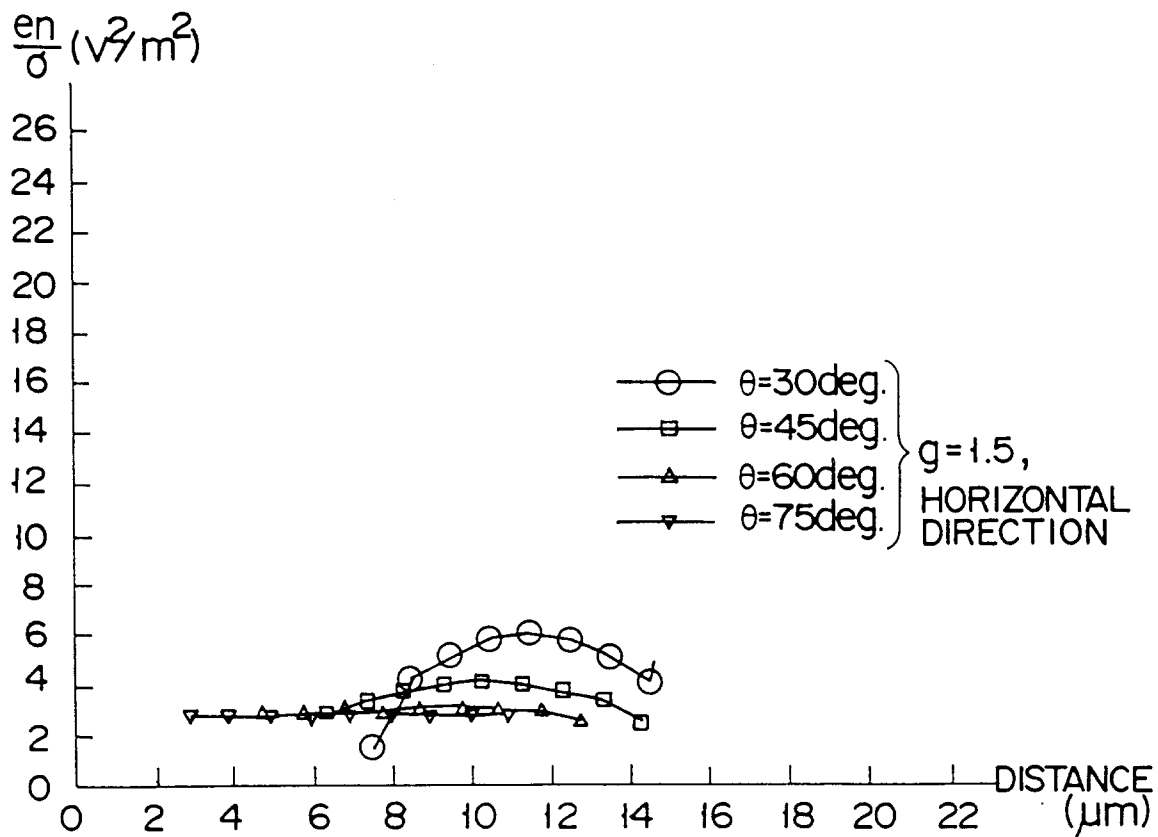

FIG. 8

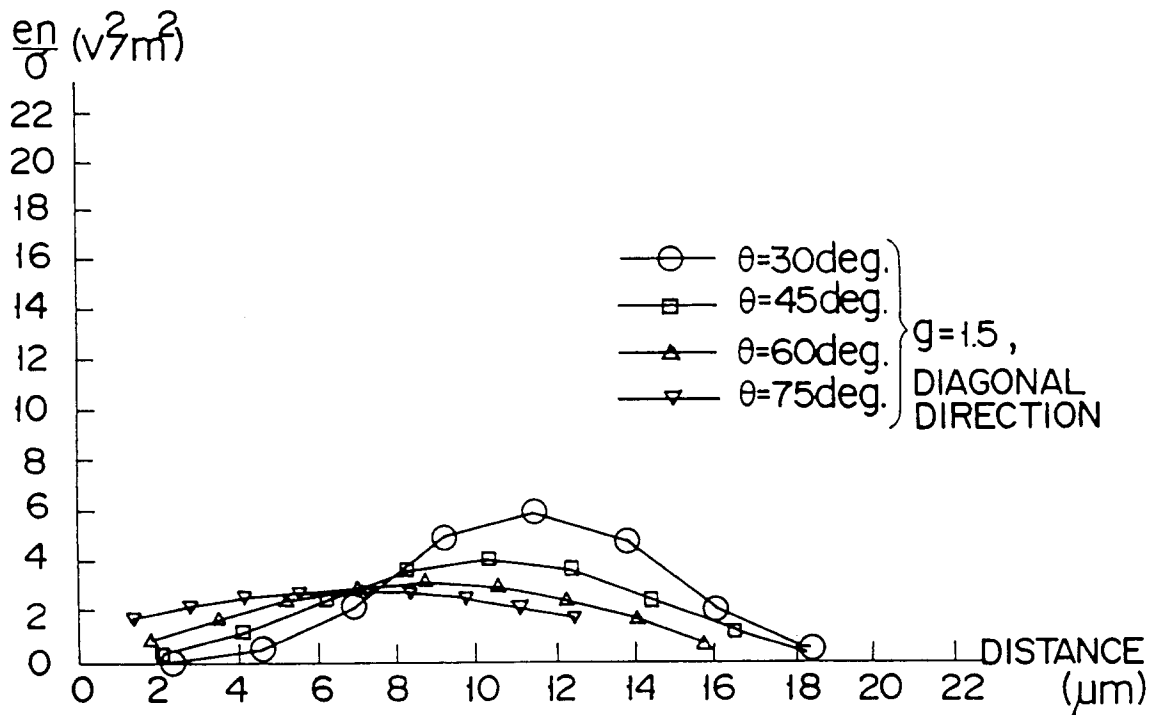

FIG. 9

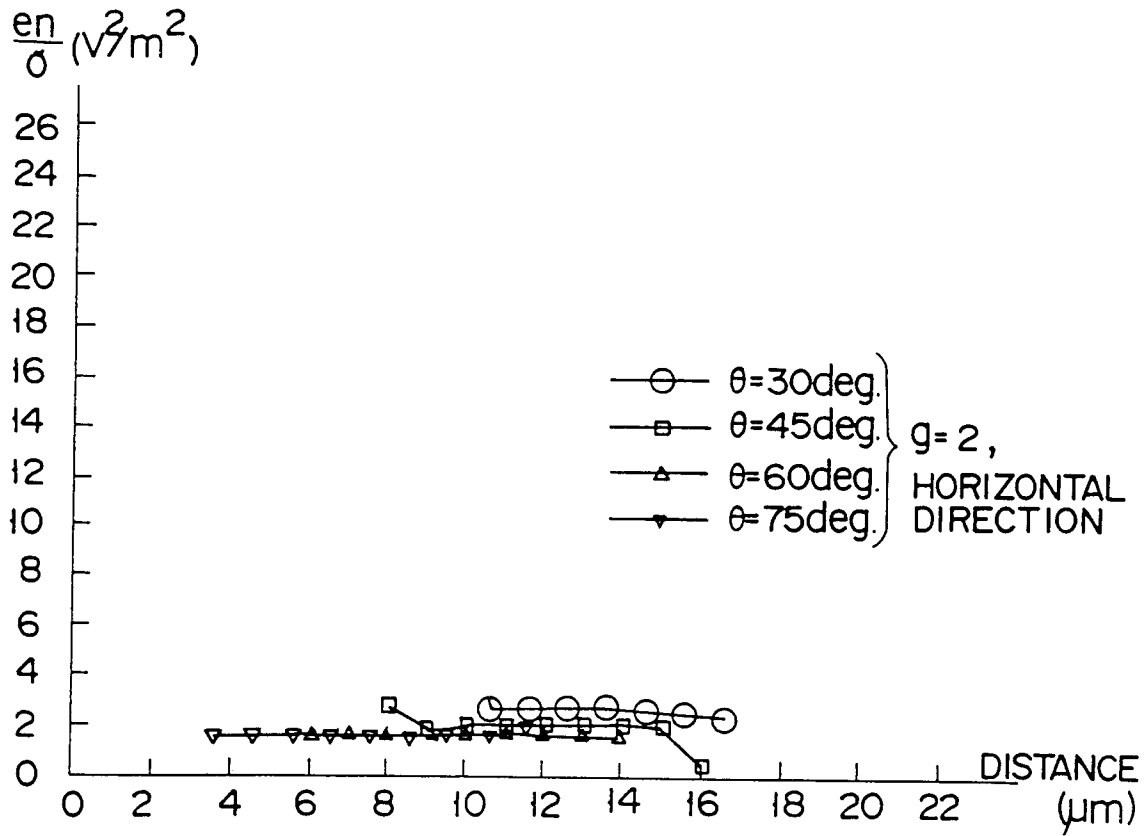

FIG. 10

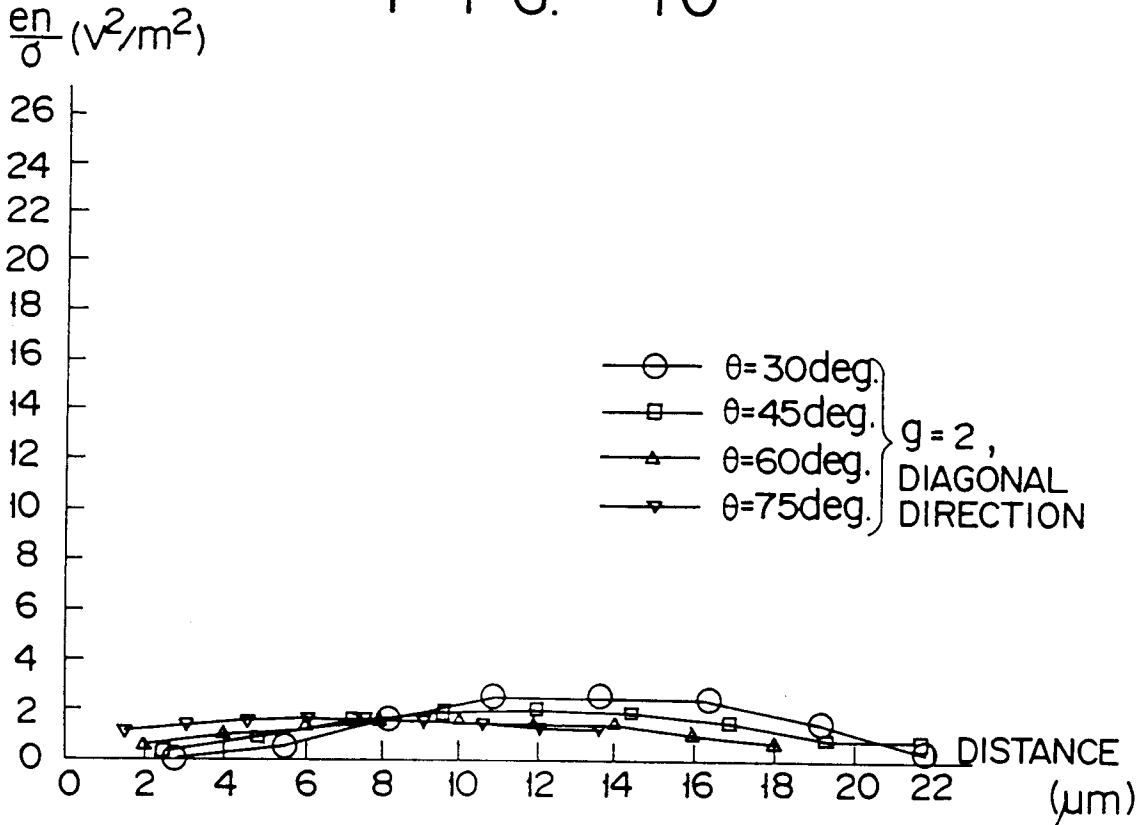

FIG. 11

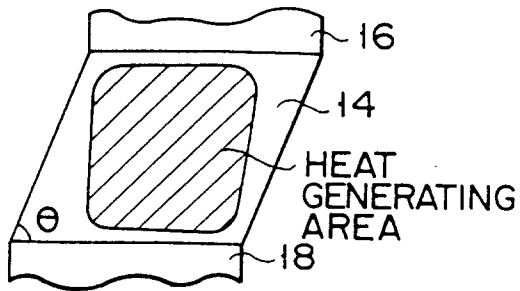

FIG. 12A

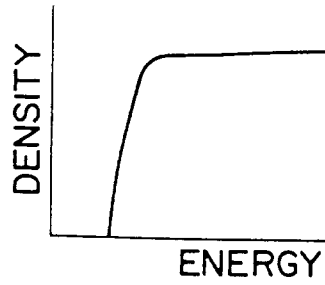

FIG. 12B

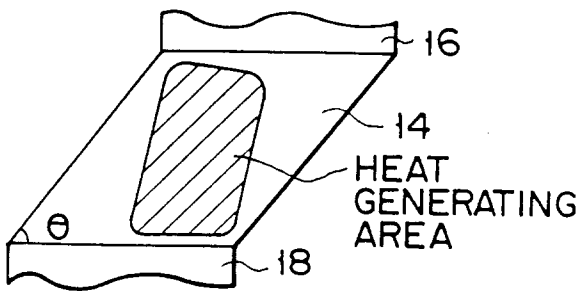

FIG. 13A

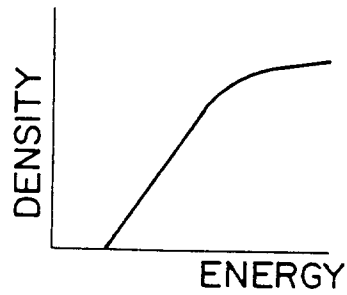

FIG. 13B

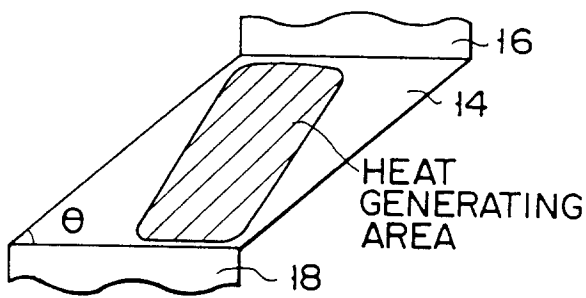

FIG. 14A

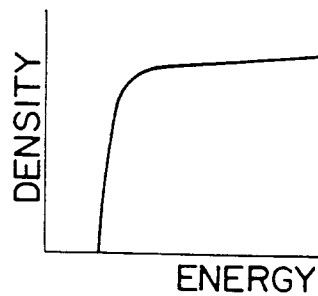

FIG. 14B

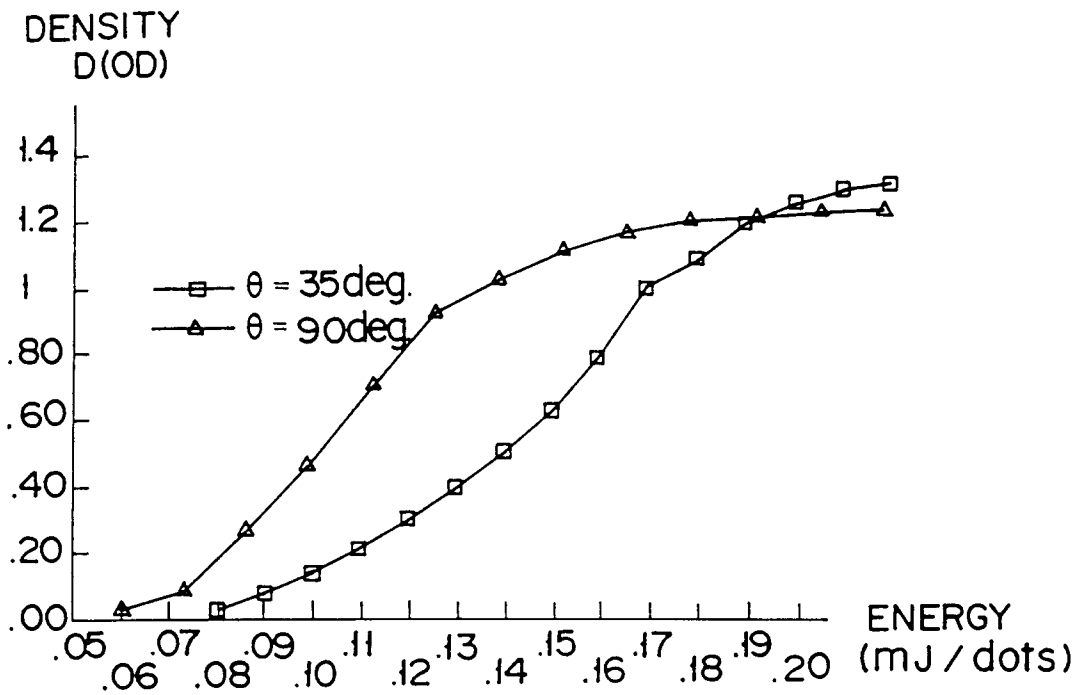

FIG. 15

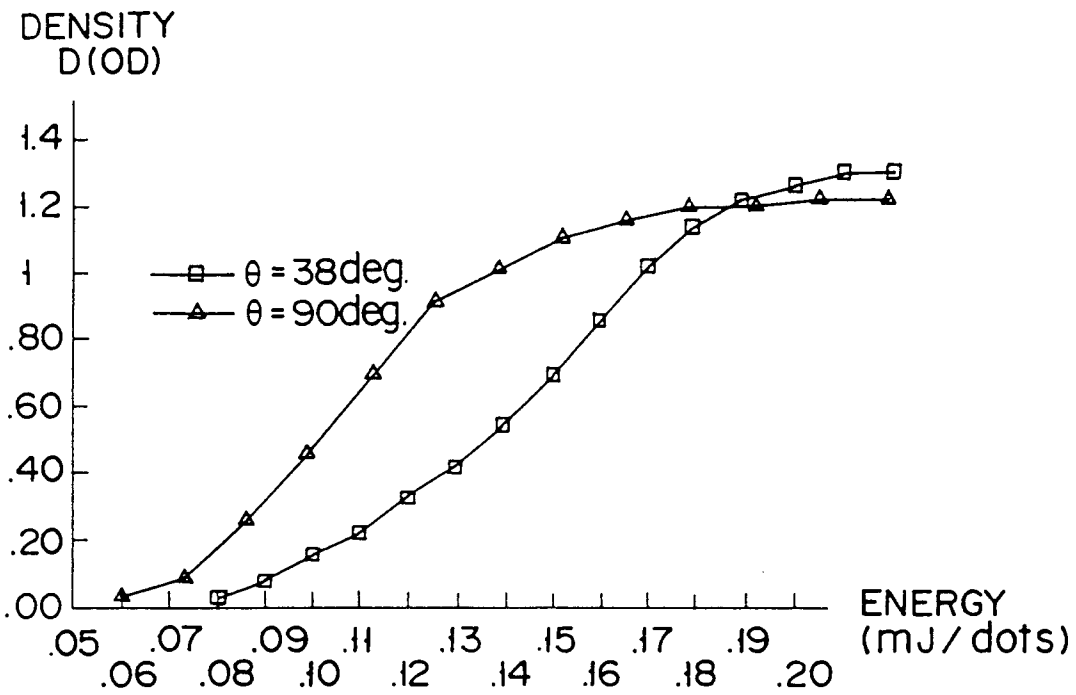

FIG. 16

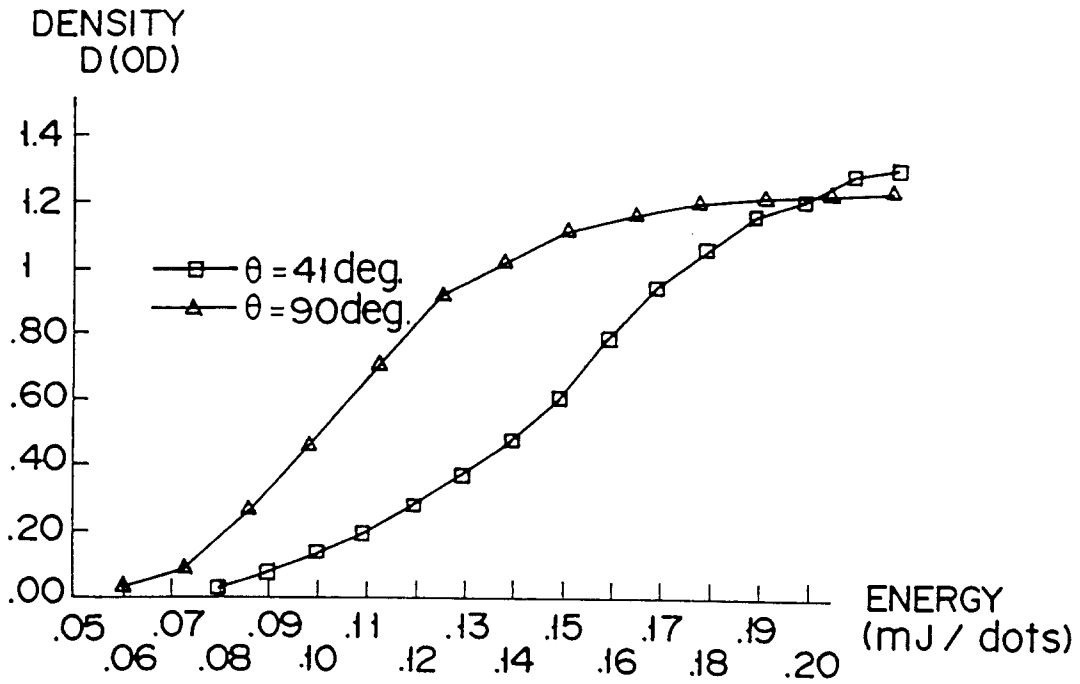

FIG. 17

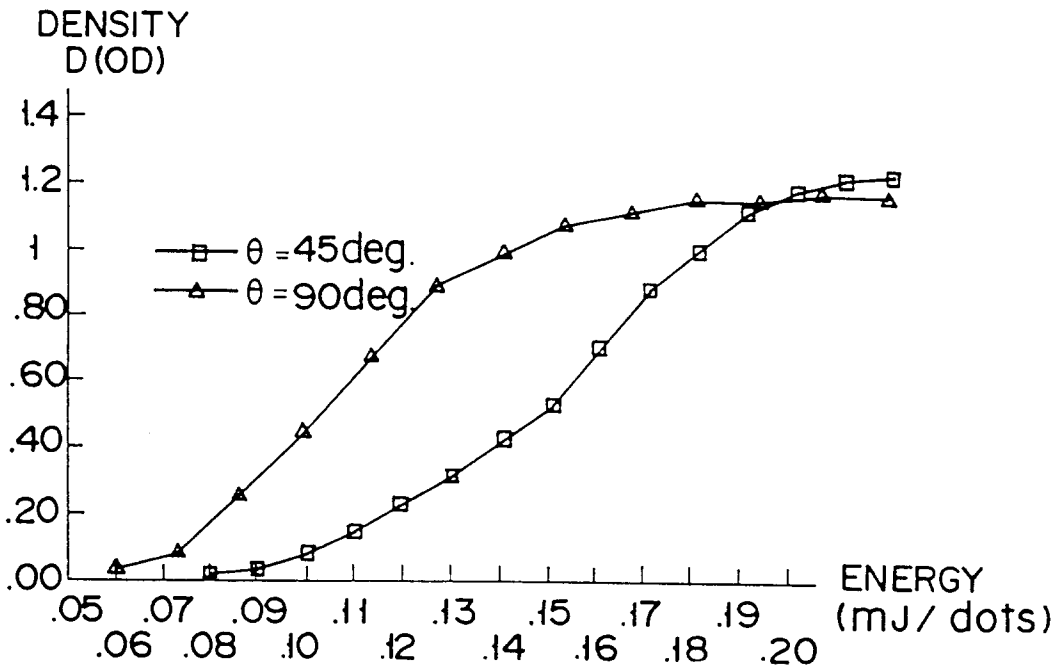

FIG. 18

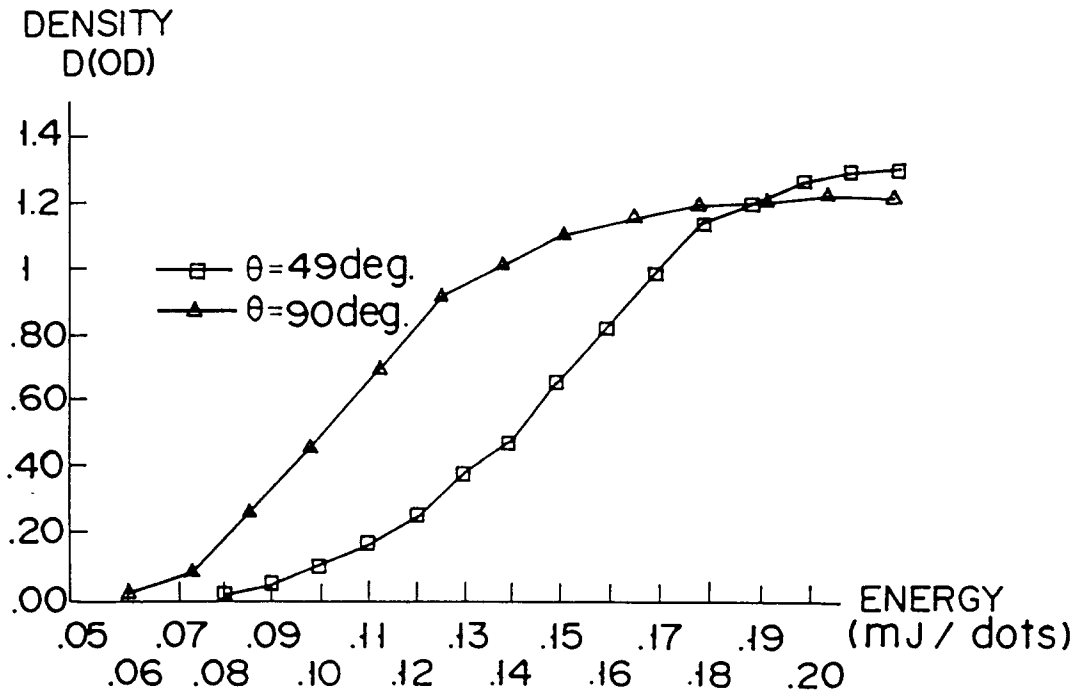

FIG. 19

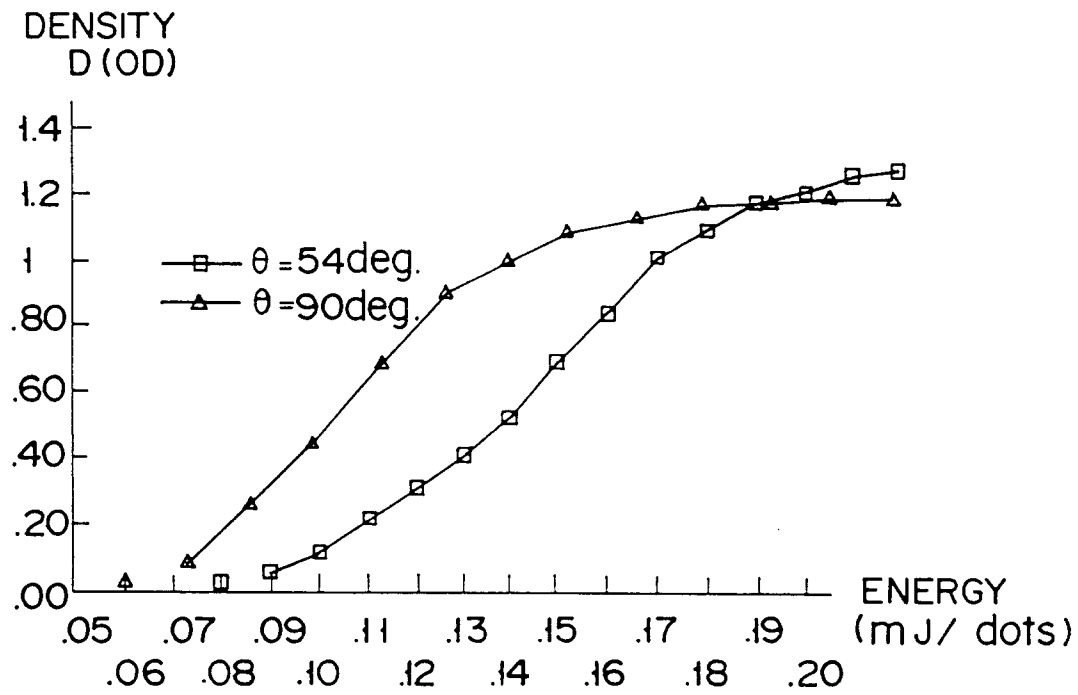

FIG. 20

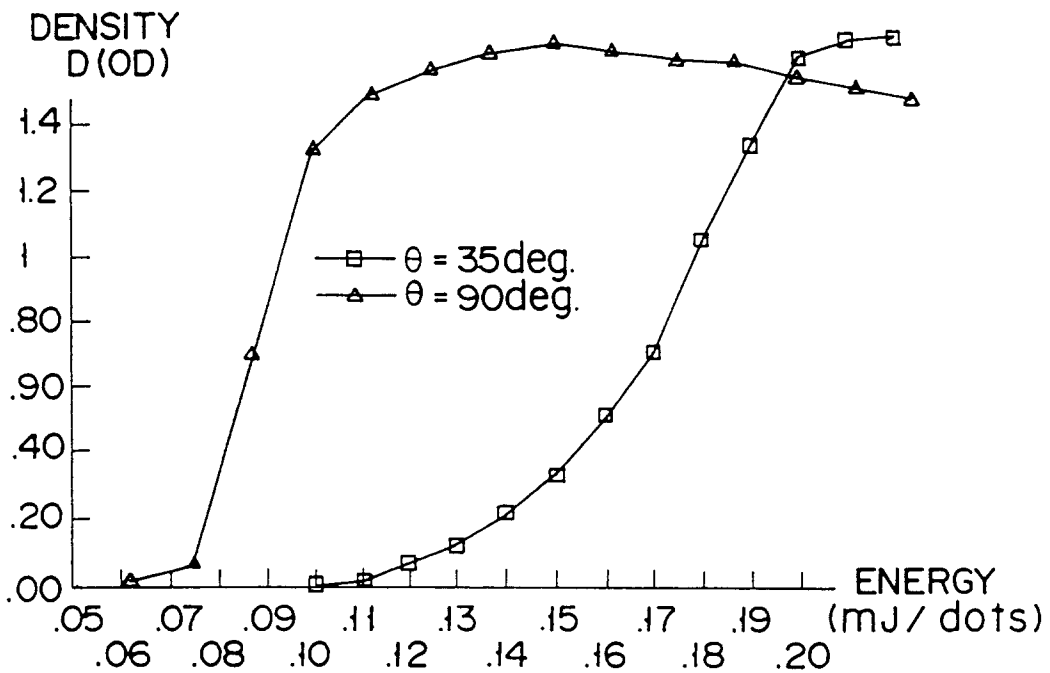

FIG. 21

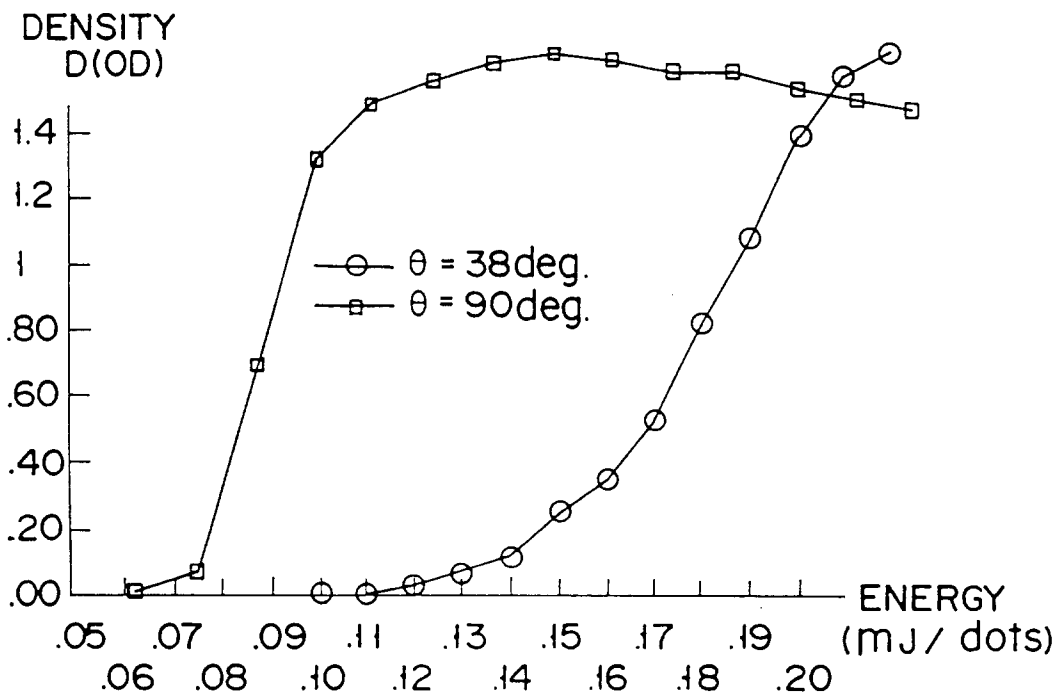

FIG. 22

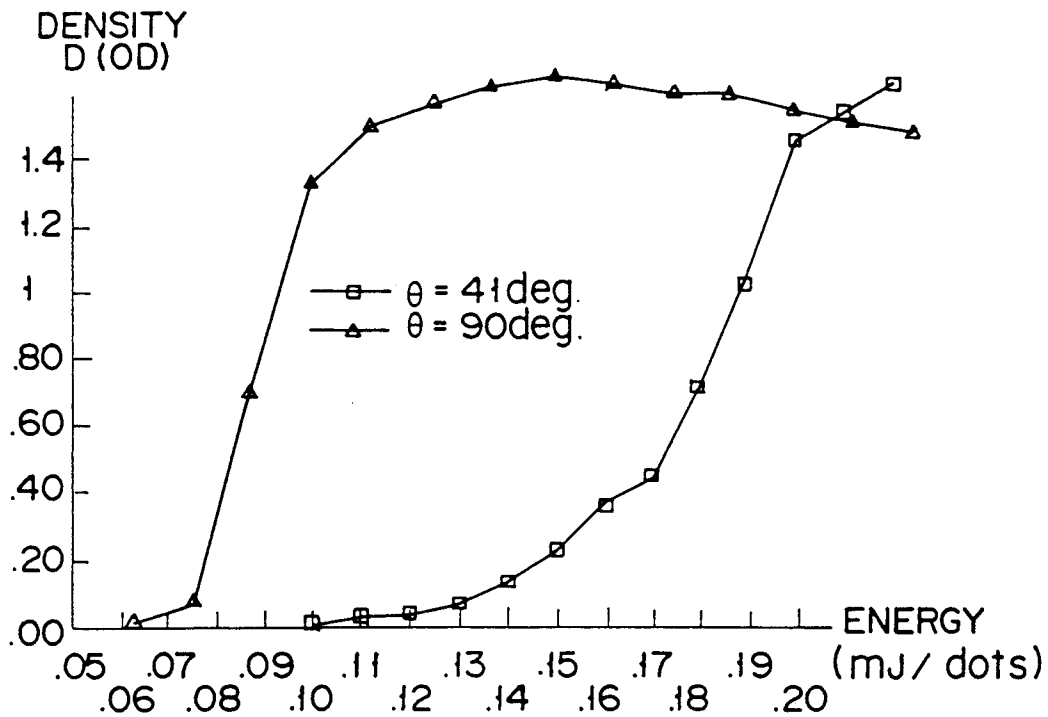

FIG. 23

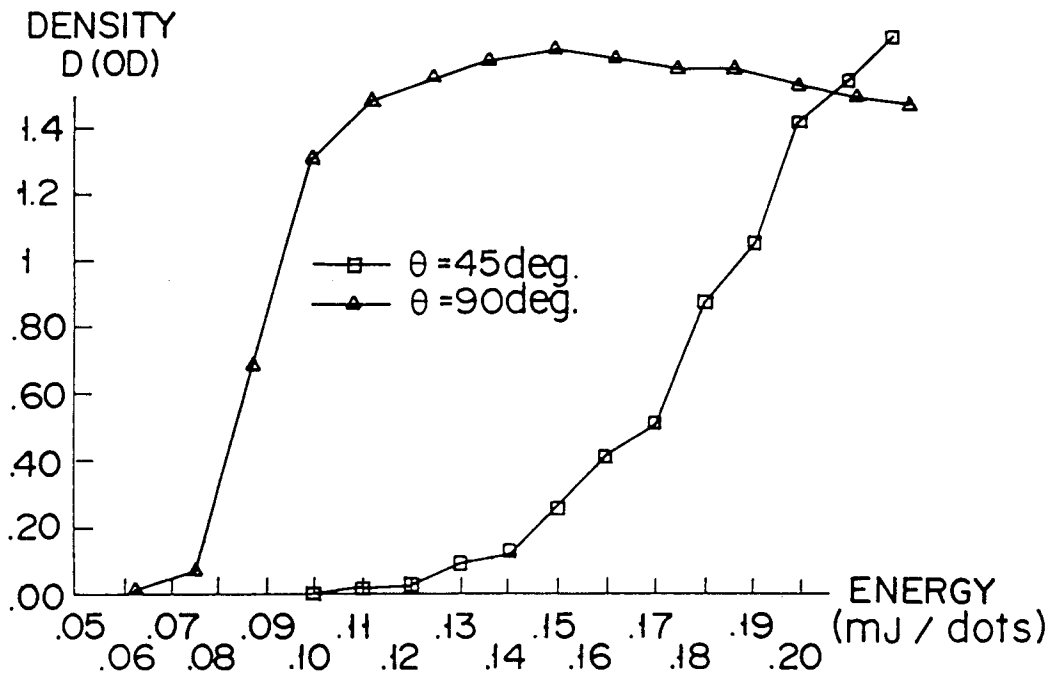
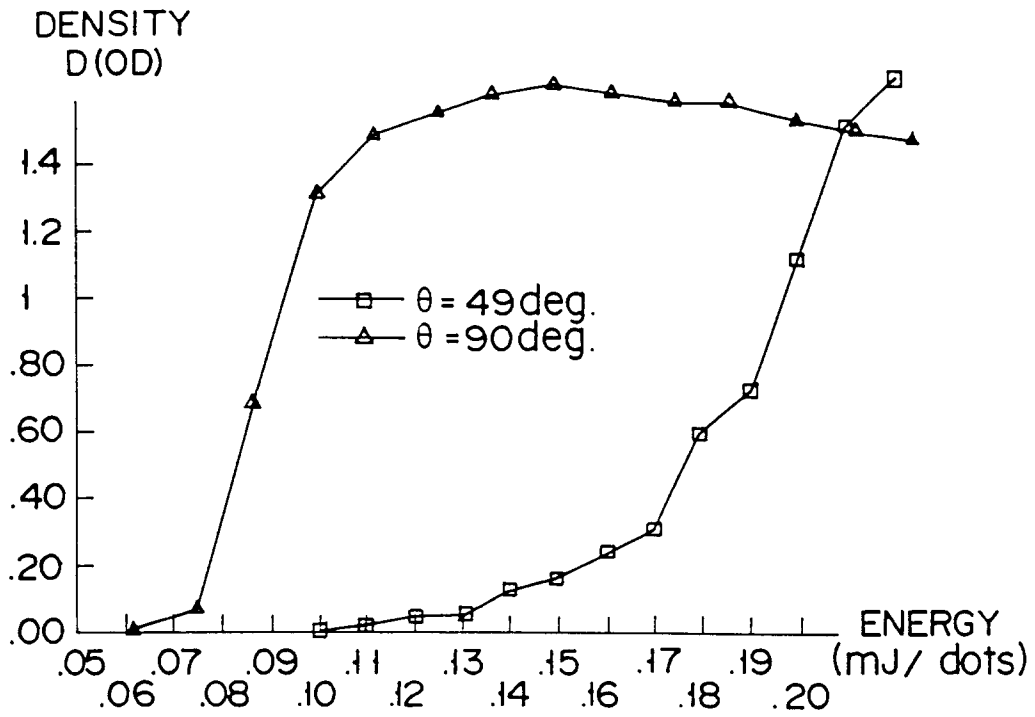
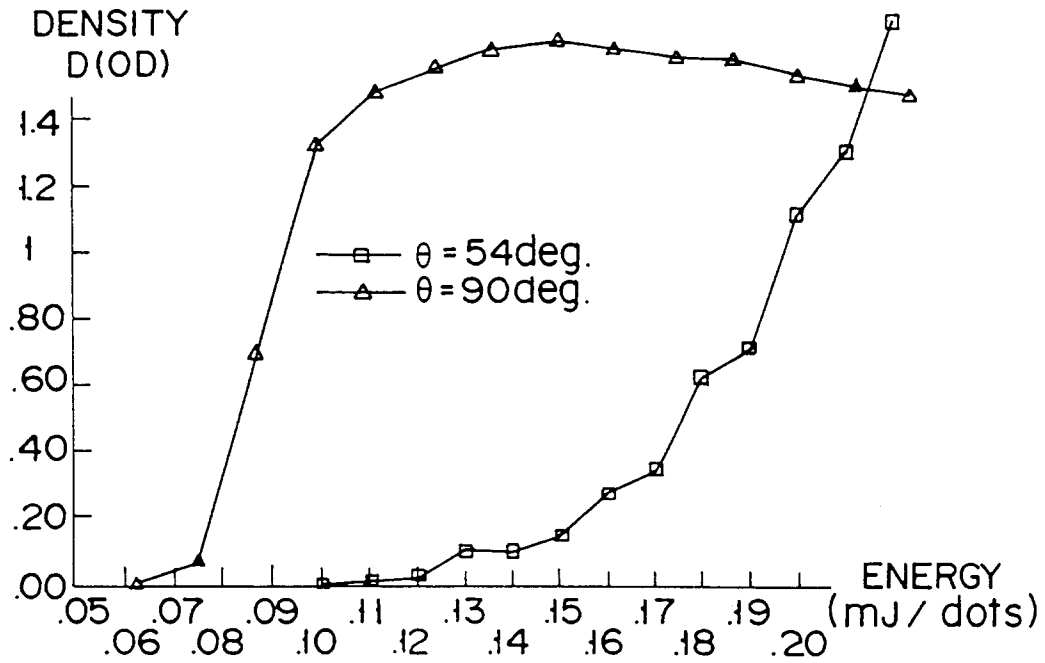

FIG. 24



F I G. 25



F I G. 26

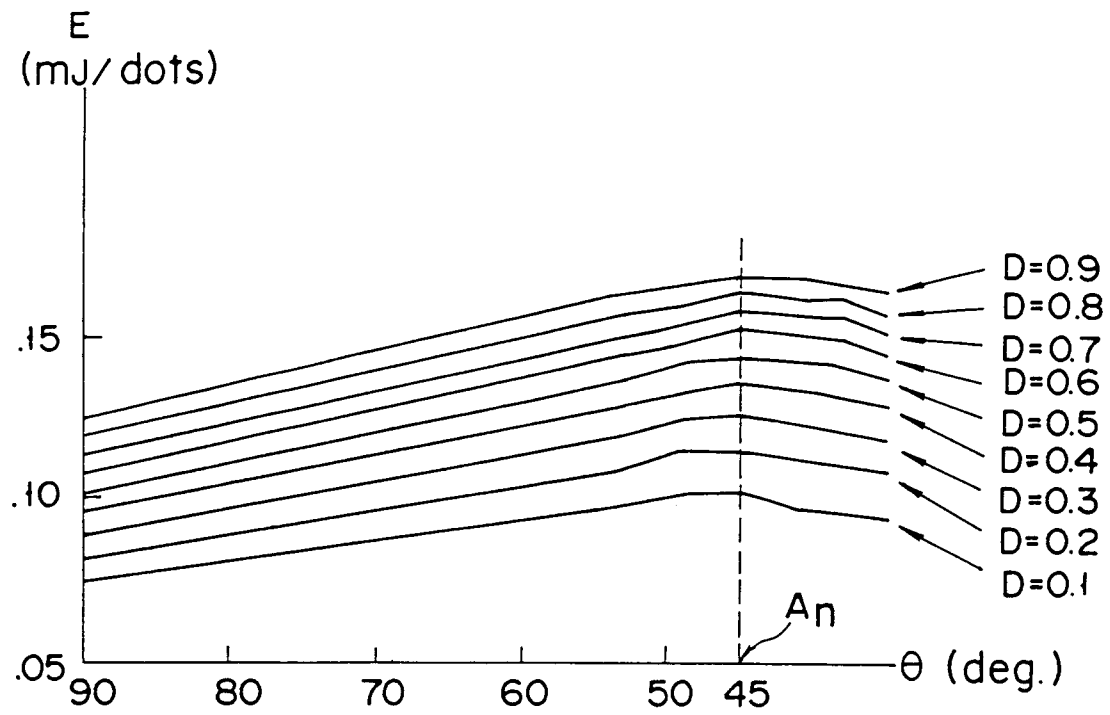

FIG. 27

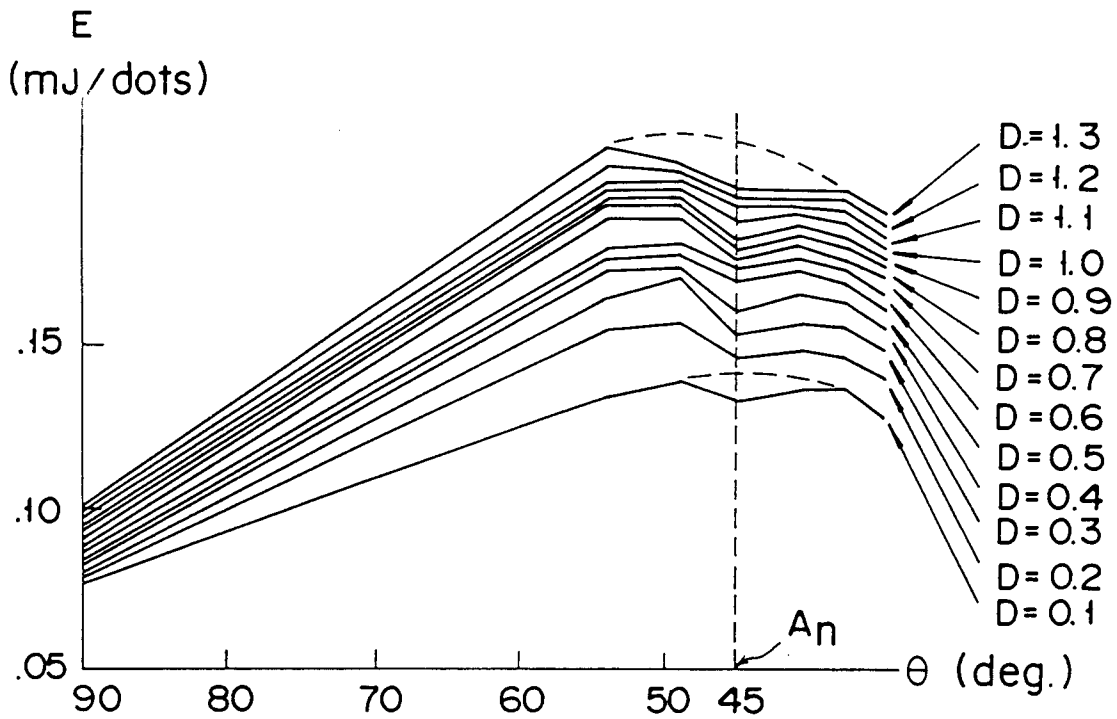
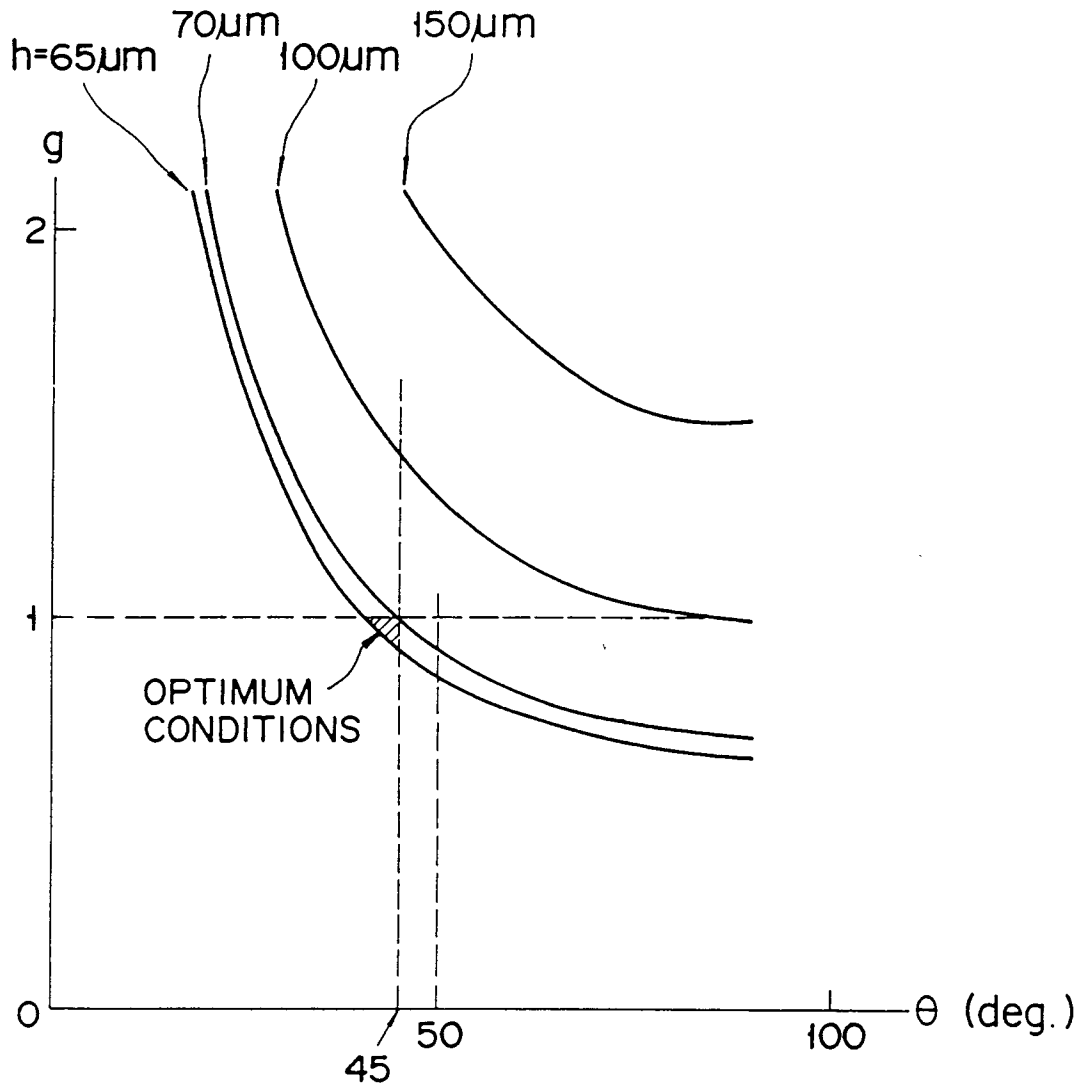

FIG. 28



F I G. 29

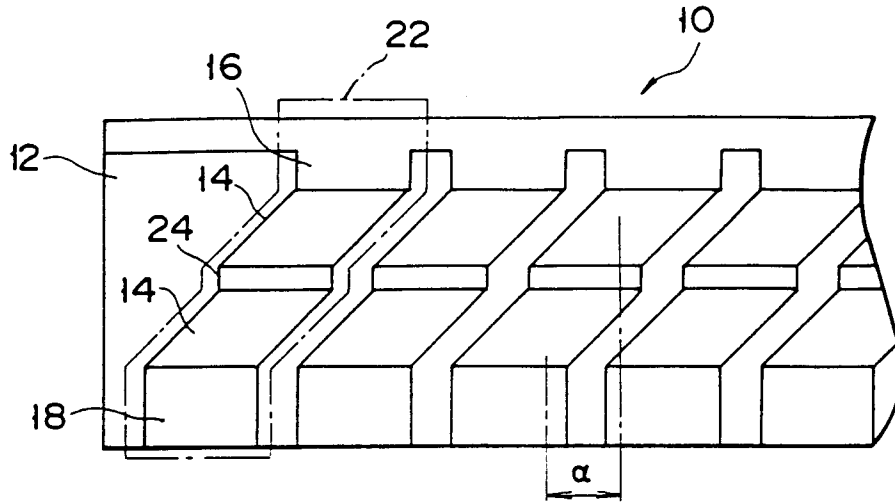

FIG. 30

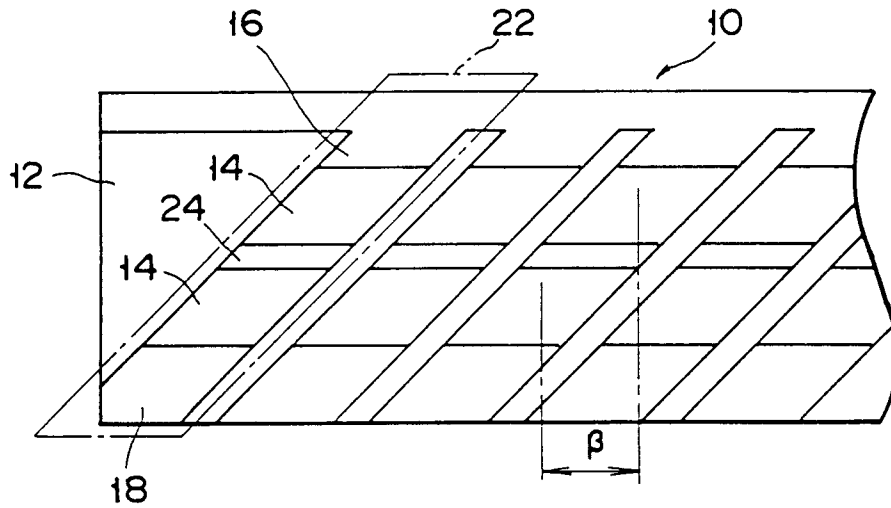

FIG. 31

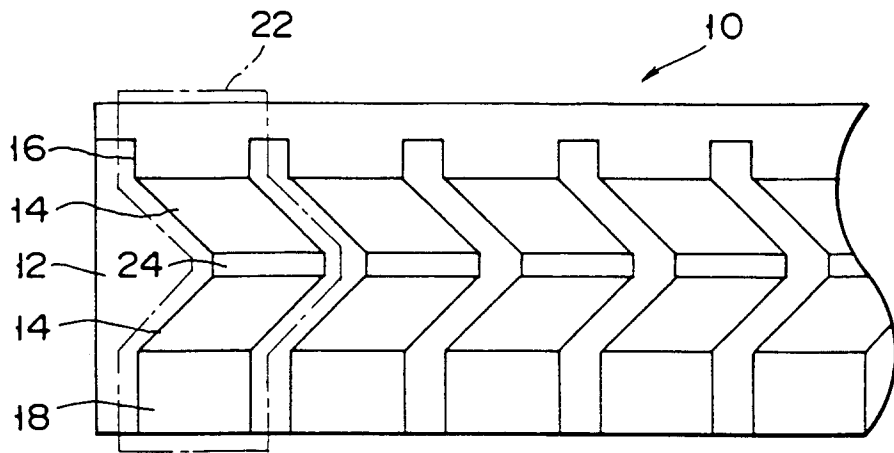

FIG. 32

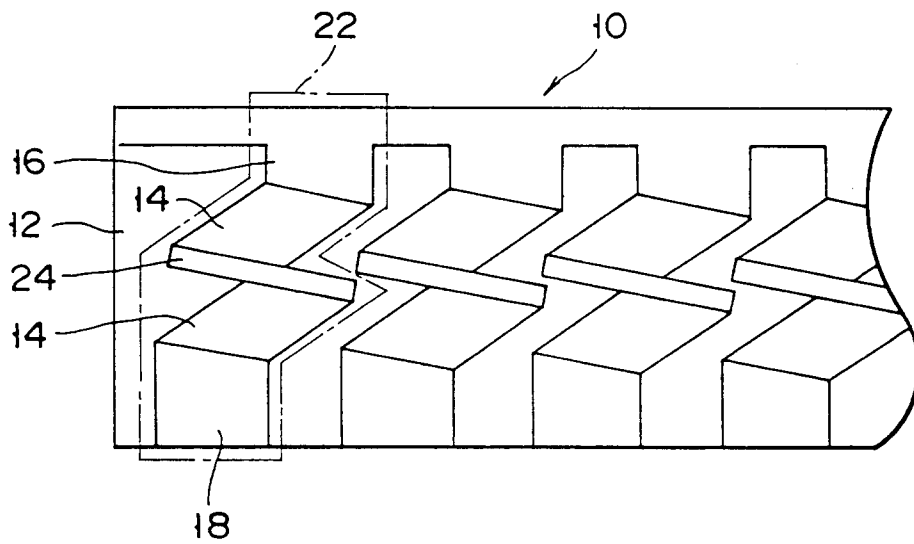

FIG. 33