

Oct. 4, 1966

G. FRANZEN

3,276,197

DOUBLE TWIST SPINDLE

Filed March 23, 1964

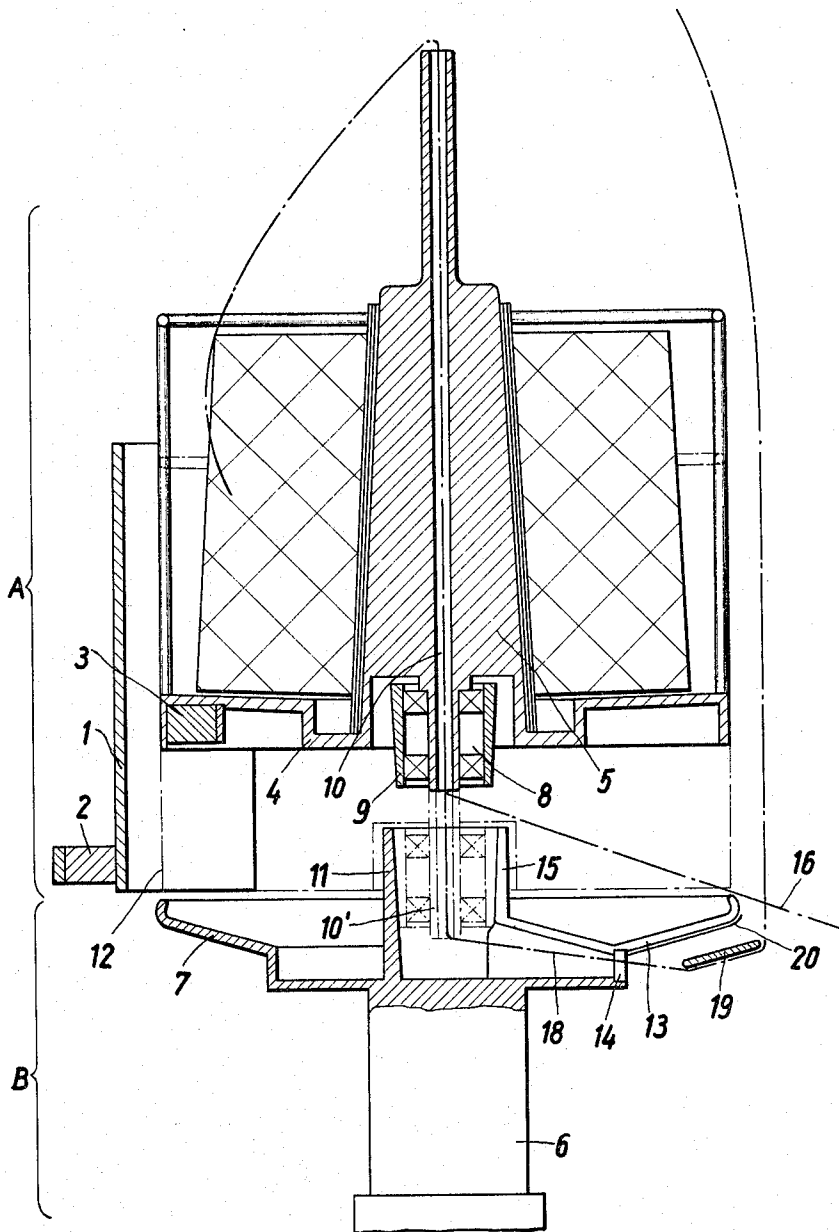

Inventor:

*Gustav Franzen*  
By *Cushman, Darby & Cushman*  
*Attorneys*

1

3,276,197

## DOUBLE TWIST SPINDLE

Gustav Franzen, Neersen, Germany, assignor, by mesne assignments, to Palitex Project-Company G.m.b.H., Krefeld, Germany, a German company

Filed Mar. 23, 1964, Ser. No. 353,718

Claims priority, application Germany, Mar. 22, 1963,

N 22,925

6 Claims. (Cl. 57—58.83)

The present invention relates to double-twist spindles. Such spindles in practice consist essentially of two parts, one carrying the bobbin and the other comprising the part, namely the wharve and deflector plate or disc which revolves relatively thereto and balloons the yarn, the bobbin-carrying part being usually held against rotation and relative rotation being permitted by the rotary part being rotatably supported by the hollow tube of the spindle.

It is difficult to handle and operate twist spindles of the aforescribed kind, and much skill is needed. For instance, the stationary and the rotating parts must be occasionally dismantled for cleaning and assembled again. The insertion of the tube into the bearing calls for a steady and skillful hand.

Threading the yarn is also an inconvenient and time-consuming operation because the yarn must be inserted into a tube and threaded through a guide opening to the outside.

The object of the present invention is to provide a double twist spindle in which these manipulations are simpler or practically eliminated.

To this end in a double-twist spindle according to the invention, the bobbin carrier is provided with a bearing and preferably an externally coned double bearing which is insertable into a suitably shaped socket in the rotary part of the spindle to support the rotary part for rotation. The coned external shape of the double bearing and the coned socket facilitate re-assembly of the two parts of the spindle when these have been dismantled.

Furthermore, the deflecting plate or disc may be provided with a slot or slit extending preferably radially, into an outlet opening for the yarn and the socket likewise provided with a slit in continuation of the former. This arrangement permits the yarn to be easily inserted in the region of the revolving plate or disc and the awkward operation of threading the same, as was necessary in the past, is thus avoided. Apart from the ease with which the spindle can be dismantled and assembled, the operation of threading the yarn is considerably simpler. The yarn need merely be drawn from the bobbin through the tube before this part of the spindle is mounted on the rotary part. After assembly of the parts the yarn will practically of its own accord pass through the slit in the deflecting plate or disc.

The drawing is a schematic vertical section of a double twist spindle exhibiting the features proposed by the present invention.

The spindle comprises a stationary part A and a rotating part B.

In conventional manner the stationary part A of the spindle carries a balloon limiter 1. This is fitted with magnets 2 which co-operate with magnets 3 on the bob-

2

bin carrier 4 for keeping the latter and hence the bobbin, which is mounted on the core 5, stationary.

The rotating part B of the spindle comprises the wharve 6 and the shallow cup-shaped deflecting plate or disc 7.

In order to permit the stationary part A and the rotating part B to be assembled in such manner that the two parts can relatively rotate, the invention proposes to fit to the bobbin carrier 4 a double bearing 8. The external surface 9 of this bearing is coned. The bearing 8 is fast on tube 10 and is insertable into a coned socket 11 provided in the rotating part B in the region of the deflecting plate or disc 7. When the stationary part A is lowered into the position indicated by dot-dash lines 12 the bearing 9 is supported inside the socket 11. The two parts can be easily fitted together and no special skill is needed.

The deflecting table has a slit or slot 13 extending to the outlet opening 14 for the yarn and thence into the socket 11 in which, as indicated at 15, the slit extends to the top. In table 7 the slit or slot 13 is preferably radial although it might be otherwise disposed.

The drawing indicates that the yarn 16 which has been threaded through the tube 10 need merely be held to register with the slit or slot when the stationary part A is fitted to the rotary part B and this will then ensure that, when tube 10 has been lowered into the position indicated in dot-dash outline 10', the yarn will be in the desired position, as indicated by line 18. All that is subsequently needed is to thread the outside end through the upper yarn guide.

In order to prevent the yarn from being re-extracted through the slit or slot 13 it is advisable to provide an intercepting means.

Such an intercepting means may have the form of a stationary plate 19 which may be attached to the frame of the machine. In order to permit such an intercepting plate to be effective the spindle should be stopped in a position in which the slit or slot 13 and the outlet 14 for the yarn point towards the operative. Means which enable this to be done have been described in an earlier proposal which has not yet been published.

Alternatively the intercepting means may be located on the deflecting plate or disc adjacent one edge of the slit in such a way that it projects across the slit. In such a case it may likewise be constituted by a plate 20. However, other embodiments such as hooklets or the like could be used.

What I claim is:

1. A double twist spindle comprising a bobbin-carrier part and a relatively rotary part for ballooning the yarn, said bobbin-carrier part being fitted with an externally coned double bearing and said rotary part having a co-operating socket into or from which said bearing is operatively insertable or withdrawable.

2. A double twist spindle comprising a bobbin-carrier part and a relatively rotary part comprising a yarn-deflecting and ballooning disc or plate, said bobbin-carrier part having a bearing and said rotary part having a co-operating socket, the said disc or plate having a slit or slot and a thread guiding outlet opening into which said slit or slot extends and said socket having a slit or slot continuing in the said disc or plate, the parts being readily engageable for operation or disengageable and permitting

3

the yarn to be passed laterally through the slits or slots into the outlet opening.

3. A double twist spindle according to claim 2, in which the said slit or slot in the plate or disc extends radially.

4. A double twist spindle according to claim 3, comprising a yarn intercepting means which prevents the yarn from traversing through the slit or slot in the plate or disc during operation of the spindle.

5. A spindle according to claim 3, comprising a stationary yarn intercepting means which prevents the yarn from traversing through the slit or slot in the plate or disc during operation of the spindle.

4

6. A spindle according to claim 3, comprising a yarn intercepting means carried by the said plate or disc for preventing the yarn from traversing through the slit or slot therein during operation of the spindle.

#### References Cited by the Examiner

#### UNITED STATES PATENTS

2,478,927	8/1949	Carter	-----	57—58.86
2,731,786	1/1956	Klein	-----	57—58.76 X

FRANK J. COHEN, *Primary Examiner*.

MERVIN STEIN, D. E. WATKINS, *Assistant Examiners*.