

C2389-AU

Form 8

(CONVENTION. Company.)

COMMONWEALTH OF AUSTRALIA

Patents Act 1952-1969

DECLARATION IN SUPPORT OF A CONVENTION APPLICATION FOR A PATENT OR PATENT OF ADDITION

(1) Here insert (in full) Name of Company.

In support of the Convention Application made by⁽¹⁾.....

EFFEM GMBH

(hereinafter referred to as the applicant) for a Patent

(2) Here insert title of Invention.

for an invention entitled:⁽²⁾.....

OR PASTY FILLING MATERIAL

WE, ROLF HORNIG, DIRECTOR OF RESEARCH AND DEVELOPMENT, AND STEVE OWENS, DIRECTOR OF MARKETING, RESPECTIVELY,

(3) Here insert full Name and Address, of Company official authorized to make declaration.

XXX OF LUTTUMER DORFSTRASSE 30, 2816 KIRCHLINTELN-LUTTUM, AND XX UELZENER STRASSE 3, 2810 VERDEN-EITZE, FEDERAL REPUBLIC OF GERMANY.

do solemnly and sincerely declare as follows:

1. ~~XXXX~~ We are authorised by the applicant for the patent

to make this declaration on its behalf.

2. The basic application as defined by Section 141 of the Act was

made in⁽⁴⁾ Federal Republic of Germany

on the 22nd day of April 19 88, by EFFEM GMBH

on the ~~XXXX~~ day of ~~XXXXXX~~ by ~~XXXXXXXXXX~~

(4) Here insert basic Country or Countries followed by date or dates and basic Applicant or Applicants.

(5) Here insert (in full) Name and Address of Actual Inventor or Inventors.

(5) JURGEN GIDEON, Am Weissen Berge 2, D-2810 Verden/Aller, DIETER KRIEGER, Kirchstrasse 37, D-2815 Langwedel-Etelsen and ERICH MENGEL, Am Hubertushain 36, D-2810 VerdenBorstel, Federal Republic of Germany

is/are the actual inventors of the invention and the facts upon which the applicant is entitled to make the application are as follow:

The applicant is the assignee of the invention from the said actual inventors

4. The basic application referred to in paragraph 2 of this Declaration was the first application made in a Convention country in respect of the invention the subject of the application.

DECLARED at VERDEN, WEST GERMANY

this 27TH day of OCTOBER, 19 89

AU

(12) PATENT ABRIDGMENT (11) Document No. AU-B-34161/89
(19) AUSTRALIAN PATENT OFFICE (10) Acceptance No. 609290

(54) Title
FEED PIPE FOR A VISCOUS OF PASTY FILLING MATERIAL

International Patent Classification(s)
(51)⁴ F17D 001/20 B65B 037/06 F16L 027/12

(21) Application No. : 34161/89 (22) Application Date : 19.04.89

(87) WIPO Number : WO89/10515

(30) Priority Data

(31) Number (32) Date (33) Country
3813574 22.04.88 DE FEDERAL REPUBLIC OF GERMANY

(43) Publication Date : 24.11.89

(44) Publication Date of Accepted Application : 26.04.91

(71) Applicant(s)
JURGEN GIDEON; DIETER KRIEGER; ERICH MENGEL

(72) Inventor(s)
JURGEN GIDEON; DIETER KRIEGER; ERICH MENGEL

(74) Attorney or Agent
WATERMARK PATENT & TRADEMARK ATTORNEYS, Locked Bag 5, HAWTHORN VIC
3122

(56) Prior Art Documents
AU 54926/86 F16L 27/12
AU 546275 78138/84 F16L 27/12

(57) Claim

1. A feed pipe for conveying from a feed pump to a filling machine viscous or pasty filling material for containers, comprising a trombone shaped section, said section having two pipe portions arranged parallel to each other and a U-shaped bend portion with parallel end sides respectively arranged to work telescopically with the parallel pipe portions, said parallel pipe portions capable of being elongated by the pressure of the conveyed material in the pipe, said U-shaped bend portion being attached to pressure regulating means which is responsive to the pressure of the conveyed material to elongate the parallel pipe portions for varying the lengths of the parallel pipe portions.

600290

OPI DATE 24/11/89

APPLN. ID 34161 / 89

AOJP DATE 21/12/89

PCT NUMBER PCT/DE89/00238

PCT

WE

INTERNATIONALES BUREAU

INTERNATIONALE ANMELDUNG VERÖFFENTLICHT NACH DEM VERTRAG ÜBER DIE
INTERNATIONALE ZUSAMMENARBEIT AUF DEM GEBIET DES PATENTWESENS (PCT)(51) Internationale Patentklassifikation⁴ :F17D 1/20, F16L 55/04
B65B 37/06

A1

(11) Internationale Veröffentlichungsnummer: WO 89/10515

(43) Internationales
Veröffentlichungsdatum: 2. November 1989 (02.11.89)

(21) Internationales Aktenzeichen: PCT/DE89/00238

(22) Internationales Anmeldedatum: 19. April 1989 (19.04.89)

(30) Prioritätsdaten:
P 38 13 574.4 22. April 1988 (22.04.88) DE(71) Anmelder (für alle Bestimmungsstaaten ausser US): EFFEM
GMBH [DE/DE]; Eitzer Landstr., D-2810 Verden/Aller
(DE).

(72) Erfinder; und

(73) Erfinder/Anmelder (nur für US): GIDEON, Jürgen [DE/
DE]; Am Weißen Berge 2, D-2810 Verden/Aller (DE).
KRIEGER, Dieter [DE/DE]; Kirchstr. 37, D-2815 Lang-
wedel-Etelsen (DE), MENGEL, Erich [DE/DE]; Am
Hubertushain 36, D-2810 Verden/Borstel (DE).(74) Anwälte: GODDAR, Heinz usw.; Boehmer & Boehmert,
Hollerallee 32, Postfach 10 71 27, D-2800 Bremen 1
(DE).

(81) Bestimmungsstaaten: AU, JP, US.

Veröffentlicht

Mit internationalem Recherchenbericht.

This document contains
amendments made under
Section 49 and is correct for
printing

FEED PIPE FOR

(54) Title: PIPELINE FOR CONVEYING A VISCOUS OR PASTY FILLING MATERIAL

(54) Bezeichnung: FÖRDERLEITUNG FÜR EIN ZÄHFLÜSSIGES ODER PASTÖSES FÜLLGUT

(57) Abstract

A pipeline for conveying a viscous or pasty filling material for filling preserve cans from a delivery pump to a filling machine comprises a section (10) in the form of a trombone tube with two parallel segments (12, 14) and a U-shaped arch (16), the arms of which co-operate telescopically with the segments (12, 14). Means (18) act on the U-shaped arch (16) against the pressure of the filling material so as to shorten the section (10).

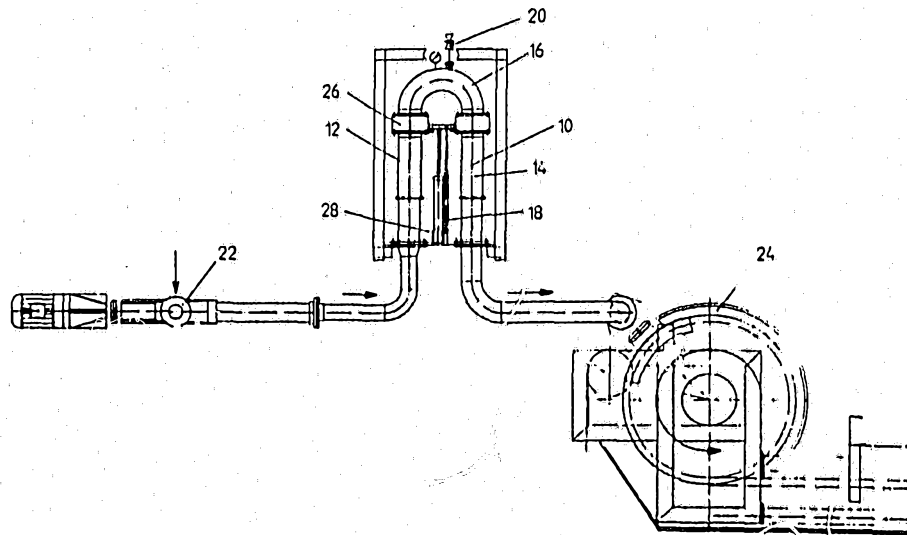

(57) Zusammenfassung

Förderleitung zum Fördern von in einer Konservendose oder dgl. abzufüllendes, zähflüssiges oder pastöses Füllgut von einer Förderpumpe zu einer Füllmaschine, mit einer posaunenrohrartig ausgebildeten Strecke (10) mit zwei sich parallel zueinander erstreckenden Abschnitten (12, 14) und einem U-förmigen Bogen (16), dessen Schenkel teleskopartig mit den Abschnitten (12, 14) zusammenwirken, wobei auf den U-förmigen Bogen (16) angreifende, gegen den Druck des Füllgutes in Richtung auf eine Verkürzung der Strecke (10) wirkende Mittel (18) vorgesehen sind.

FEED PIPE FOR A VISCOUS OF PASTY

FILLING MATERIAL

This invention relates to a feed pipe for conveying
from a feed pump to a filling machine viscous or pasty
5 filling material for containers, tins or similar.

When filling tins with viscous or pasty filling
material, the following problem arises: the filling
operation is drastically impaired by pressure changes in the
feed pipe which results from changes in feed pump capacity
10 and/or filling capacity.

It is an object of the present invention to
maintain a substantially even pressure in the feed pipe.

In accordance with the present invention, there is
provided a feed pipe for conveying from a feed pump to a
15 filling machine viscous or pasty filling material for
containers, comprising a trombone shaped section, said
section having two pipe portions arranged parallel to each
other and a U-shaped bend portion with parallel end sides
respectively arranged to work telescopically with the
20 parallel pipe portions, said parallel pipe portions capable
of being elongated by the pressure of the conveyed material
in the pipe, said U-shaped bend portion being attached to

Dis. 12/1/30



pressure regulating means which is responsive to the pressure of the conveyed material to elongate the parallel pipe portions for varying the lengths of the parallel pipe portions.

5 More specifically, the pressure regulating means may tend to reduce the lengths of the parallel pipe portions in the case of a drop in the pressure of the conveyed material in the pipe.

10 In one embodiment, the pressure regulating means may be a pneumatic or hydraulic cylinder/piston unit, for example an actuator.

Further, a device may also be provided to measure the length of the section at any time.

15 In another embodiment, the section may be positioned vertically and have a venting device on the highest point of the U-shaped bend portion.

Other characteristics and advantages of the invention may be seen from the description which describes the drawings of an embodiment of the invention.

20 The drawings show:

Figure 1 - a complete layout of the feed pipe;

Figure 2 - a view of the section in retracted position; and



Fig. 3 a view of the section in extended position.

Feed pump 22 and filling machine 24 are connected with a feed pipe which has an inserted section 10. This section consists of two parallel positioned parts 12 and 14 and a U-shaped bend 16, whereby the sides of bend 16 are arranged in such a way, that they are telescopically moveable in the straight parts 12 and 14. The section 10 has also a hydraulic or pneumatic actuator 28 which is attached to the flanges 26 and acts as a force on the bend 16, sliding its sides into parts 12 and 14 of section 10. A device 18, situated parallel to actuator 28 and mounted on section 10, monitors the length of section 10.

The section 10 maintains an even pressure in the feed pipe:

As soon as the pump capacity of feed pump 22 rises above the filling capacity of filling machine 24 the pressure in the feed pipe will increase. This results in the sliding out of the U-shaped bend 16 from parts 12 and 14 against the force of the actuator. This extension of section 10 causes the pressure in the feed pipe to drop.

As soon as the pressure in the feed pipe drops due to a lower pump capacity the U-shaped bend 16 will slide into parts 12 and 14 of section 10 due to the force of actuator 28,



which leads to a reduction of the length of section 10 and thereby to an increase of pressure in the feed pipe. The continuous assimilation of the length of section 10 to the current feed pressure maintains an even feed pressure.

- 5 The device 18 on a preferred design example, which monitors the current length of the section, enables the feed capacity to be controlled in such a way that the section 10 assumes a standard position which is between the retracted position of Fig. 2 and the extended position of Fig.3. Thereby occurring positive and negative pressure changes can be compensated for.

The Fig. 2 and 3 show a vertical positioning of section 10 and a venting device at the highest point of the U-shaped bend 16 to release air which collects at the highest point of the bend. This venting device 20 also allows air to escape which has been conveyed with the product on start-up of the plant.

Due to the trombone like design of section 10, its length is changed twice the amount of that of the actuator 28. The mechanical construction is simple and the pressure requirement of actuator 28, acting against the feed pressure, can be easily established.

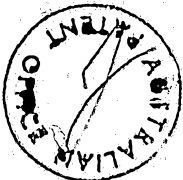

THE CLAIMS DEFINING THE INVENTION ARE AS FOLLOWS:

1. A feed pipe for conveying from a feed pump to a filling machine viscous or pasty filling material for containers, comprising a trombone shaped section, said section having two pipe portions arranged parallel to each other and a U-shaped bend portion with parallel end sides respectively arranged to work telescopically with the parallel pipe portions, said parallel pipe portions capable of being elongated by the pressure of the conveyed material in the pipe, said U-shaped bend portion being attached to pressure regulating means which is responsive to the pressure of the conveyed material to elongate the parallel pipe portions for varying the lengths of the parallel pipe portions.

2. A feed pipe according to claim 1, wherein said pressure regulating means tends to reduce the lengths of the parallel pipe portions in the case of a drop in the pressure of the conveyed material in the pipe.

3. A feed pipe according to claim 1 or 2, wherein said pressure regulating means is a pneumatic or hydraulic actuator.



4. A feed pipe according to any one of the preceding claims, wherein monitor means is attached to the U-shaped bend portion for recording or measuring the length of the trombone shaped section.

5. A feed pipe according to any one of the preceding claims, wherein the trombone shaped section is positioned vertically with the U-shaped bend portion inverted in an upper position and has a venting device at the highest point of the U-shaped bend portion.

6. A feed pipe substantially as hereinbefore described with reference to the accompanying drawings.

DATED this 20th day of November, 1990.

EFFEM GMBH

WATERMARK PATENT ATTORNEYS
2ND FLOOR "THE ATRIUM",
290 BURWOOD ROAD,
HAWTHORN, VIC. 3122.
AUSTRALIA

Disk 0891.30



17·10·90 34181

Fig.1

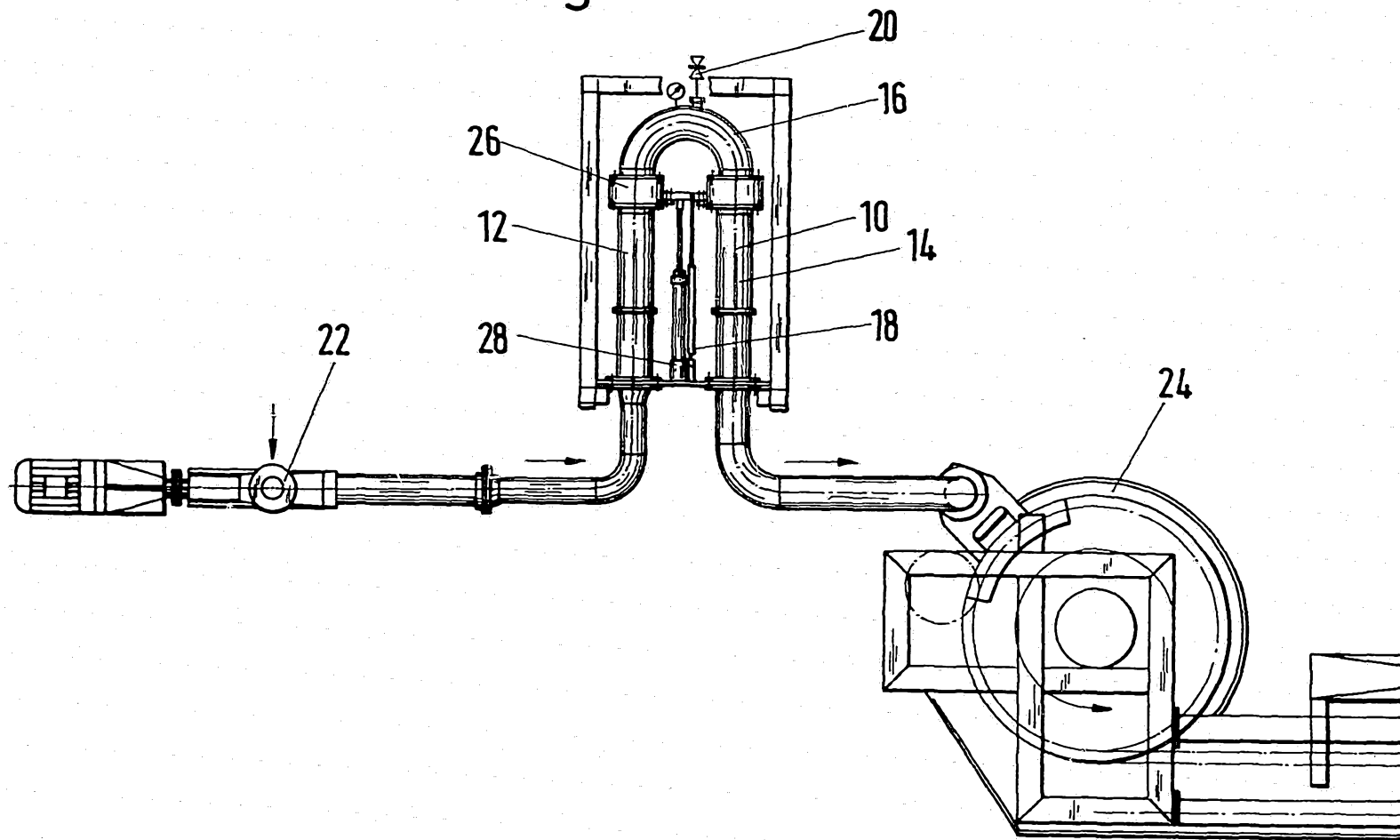

Fig. 2

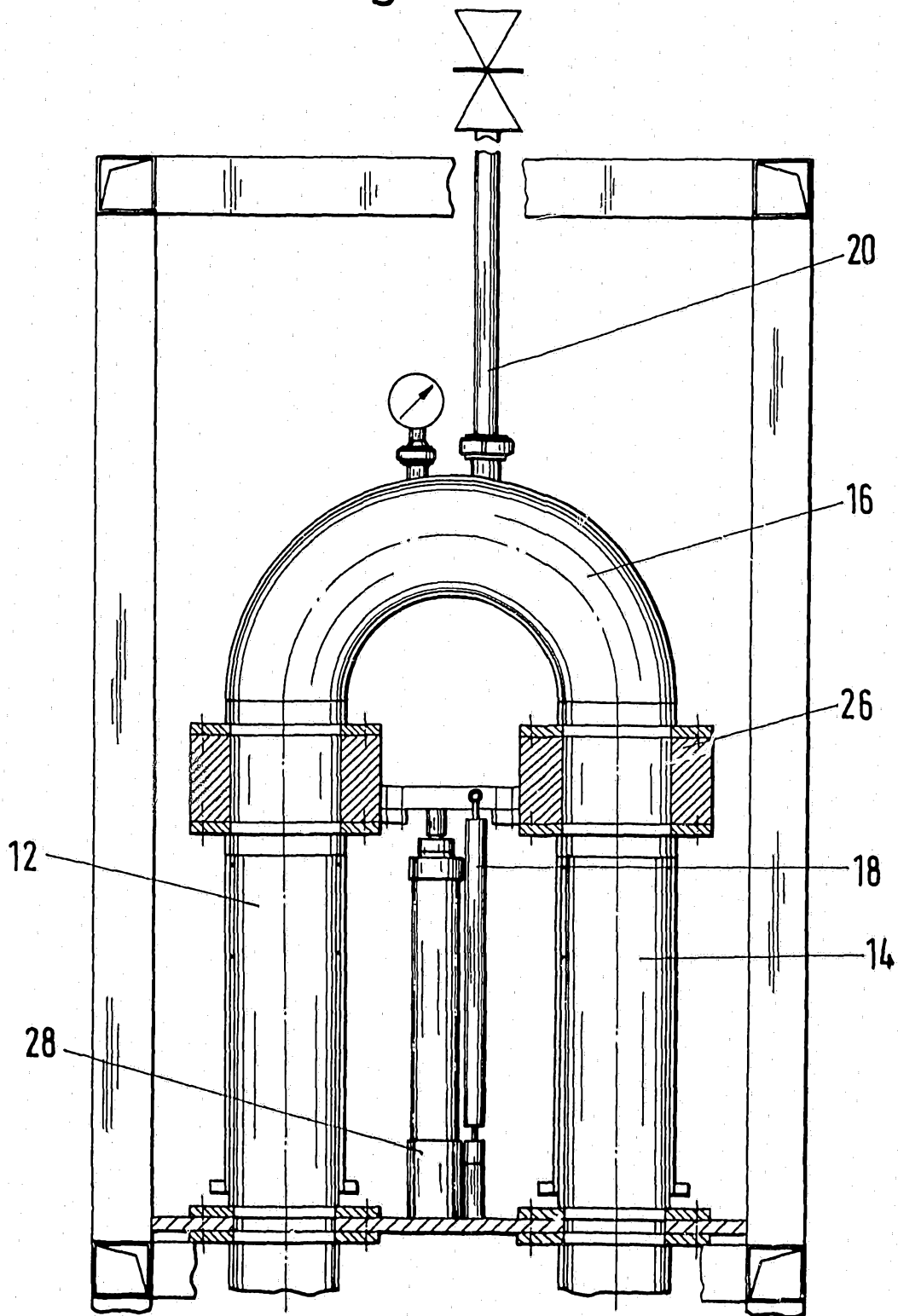
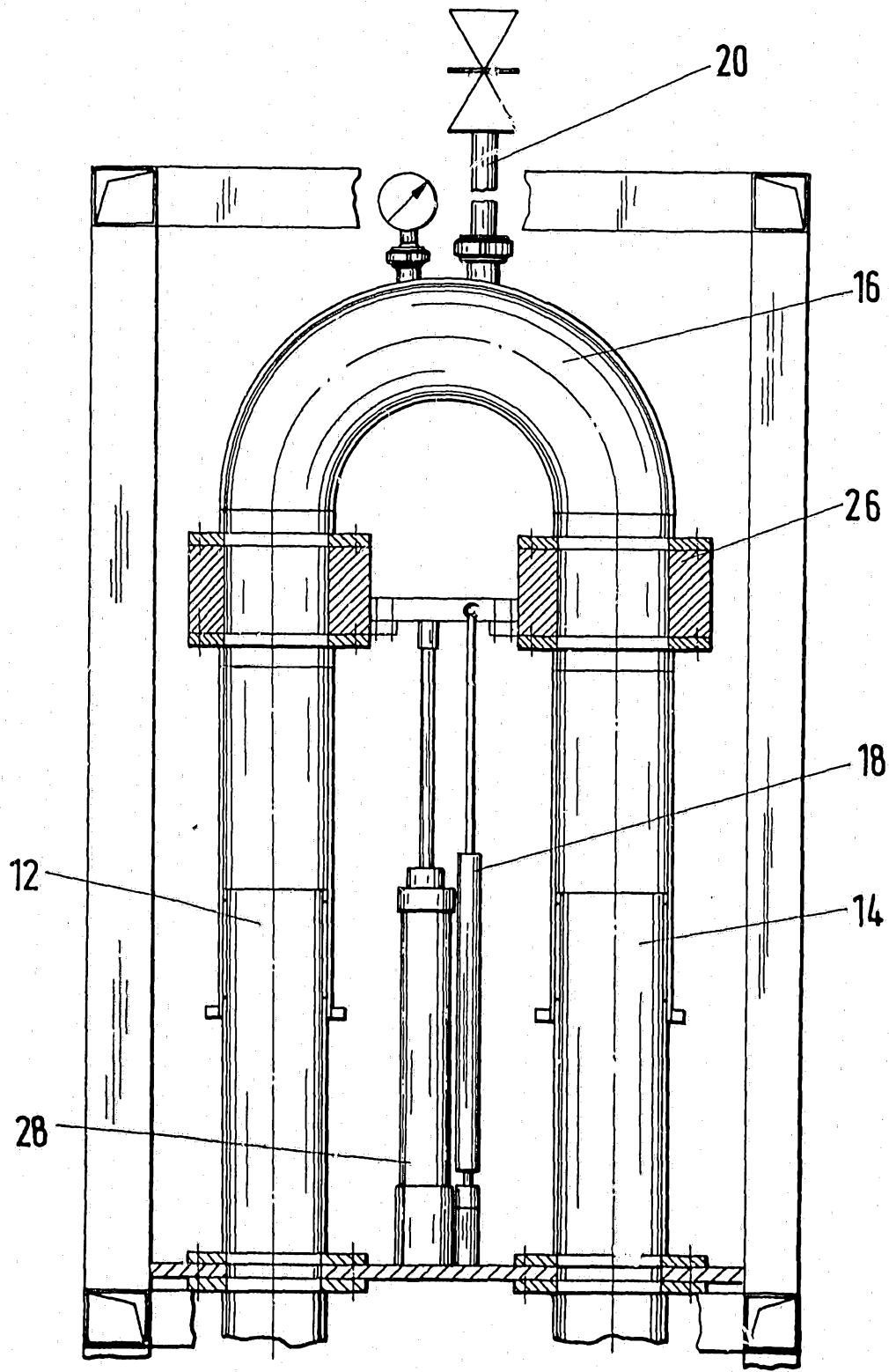

Fig. 3



INTERNATIONAL SEARCH REPORT

International Application No PCT/DE 89/00238

I. CLASSIFICATION OF SUBJECT MATTER (If several classification symbols apply, indicate all) ⁶		
According to International Patent Classification (IPC) or to both National Classification and IPC		
Int. Cl. ⁴ F 17 D 1/20, F 16 L 55/04, B 65 B 37/06		
II. FIELDS SEARCHED		
Minimum Documentation Searched ⁷		
Classification System	Classification Symbols	
Int. Cl. ⁴	F 17 D, F 16 L, B 65 B	
Documentation Searched other than Minimum Documentation to the extent that such Documents are Included in the Fields Searched ⁸		
III. DOCUMENTS CONSIDERED TO BE RELEVANT ⁹		
Category ⁹	Citation of Document, ¹¹ with indication, where appropriate, of the relevant passages ¹²	Relevant to Claim No. ¹³
A	US, A, 3487855 (J. LAUTENBERGER) 6 January 1970 see column 1, line 52 - column 2, line 32; figs. 1-3	1
A	WO, A, 85/04463 (INGEMANSSONS) 10 October 1985 see page 2, line 16 - page 3, line 11; claims; fig. 2	1

<p>⁹ Special categories of cited documents: ¹⁰</p> <p>"A" document defining the general state of the art which is not considered to be of particular relevance</p> <p>"E" earlier document but published on or after the international filing date</p> <p>"L" document which may throw doubts on priority claim(s) or which is cited to establish the publication date of another citation or other special reason (as specified)</p> <p>"O" document referring to an oral disclosure, use, exhibition or other means</p> <p>"P" document published prior to the international filing date but later than the priority date claimed</p> <p>"T" later document published after the international filing date or priority date and not in conflict with the application but cited to understand the principle or theory underlying the invention</p> <p>"X" document of particular relevance; the claimed invention cannot be considered novel or cannot be considered to involve an inventive step</p> <p>"Y" document of particular relevance; the claimed invention cannot be considered to involve an inventive step when the document is combined with one or more other such documents, such combination being obvious to a person skilled in the art.</p> <p>"Δ" document member of the same patent family</p>		
IV. CERTIFICATION		
Date of the Actual Completion of the International Search	Date of Mailing of this International Search Report	
10 July 1989 (10.07.89)	1 August 1989 (01.08.89)	
International Searching Authority	Signature of Authorized Officer	
EUROPEAN PATENT OFFICE		

ANNEX TO THE INTERNATIONAL SEARCH REPORT
ON INTERNATIONAL PATENT APPLICATION NO.

DE 8900238
SA 27980

This annex lists the patent family members relating to the patent documents cited in the above-mentioned international search report. The members are as contained in the European Patent Office EDP file on 25/07/89. The European Patent Office is in no way liable for these particulars which are merely given for the purpose of information.

Patent document cited in search report	Publication date	Patent family member(s)	Publication date
US-A- 3487855	06-01-70	None	
WO-A- 8504463	10-10-85	SE-B- 442904	03-02-86
		DE-A- 3564999	20-10-88
		EP-A, B 0177548	16-04-86
		JP-T- 61501653	07-08-86
		SE-A- 8401717	29-09-85