

F. J. WOOSTER.

MACHINE FOR SCOURING AND DRYING SHEET METAL.

No. 334,209.

Patented Jan. 12, 1886.

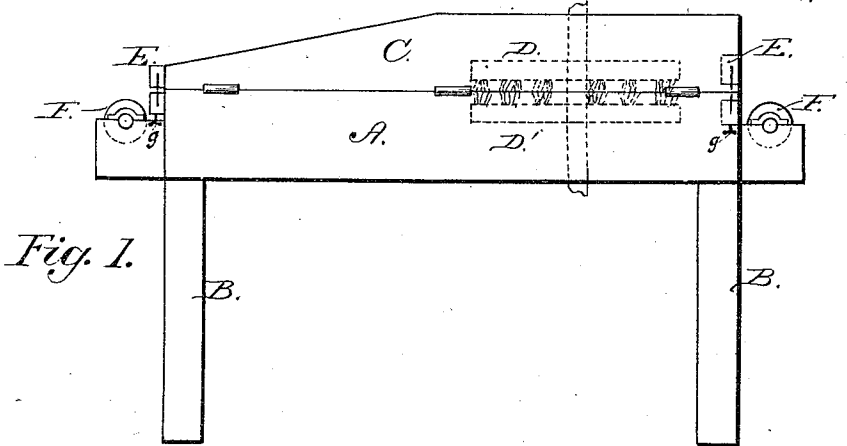

Fig. 1.

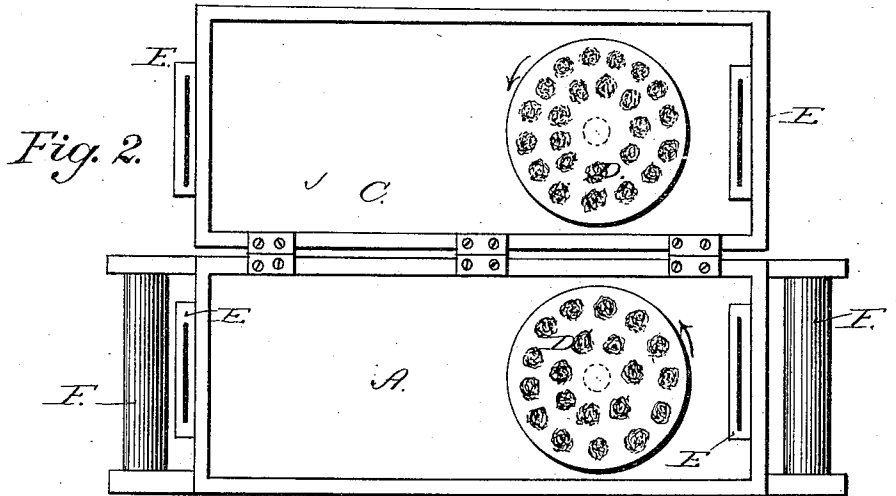

Fig. 2.

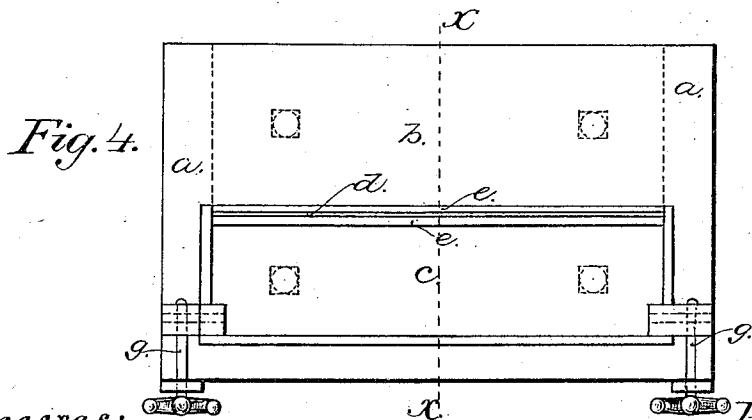

Fig. 4.

Witnesses:
 Harry Rohrer
 J. B. Adriaans.

Inventor:
 Frederick J. Wooster,
 By Parker & Sweetser
 Attys.

(No Model.)

2 Sheets—Sheet 2.

F. J. WOOSTER.

MACHINE FOR SCOURING AND DRYING SHEET METAL.

No. 334,209.

Patented Jan. 12, 1886.

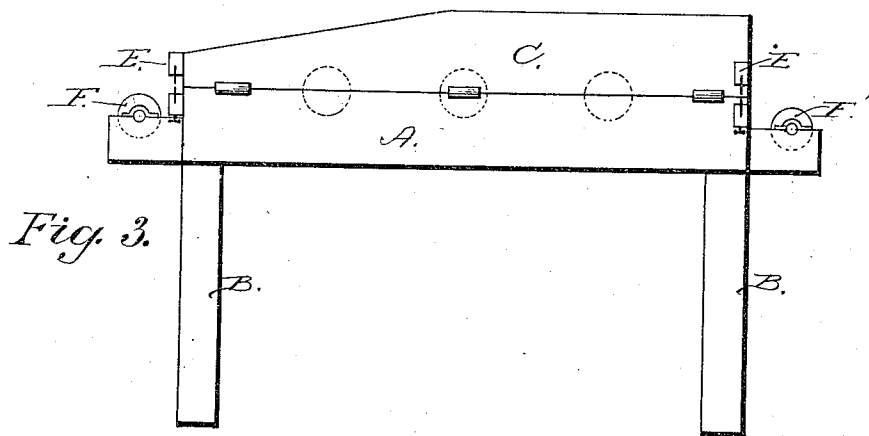

Fig. 3.

Fig. 5.

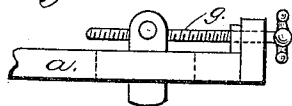

Fig. 6.

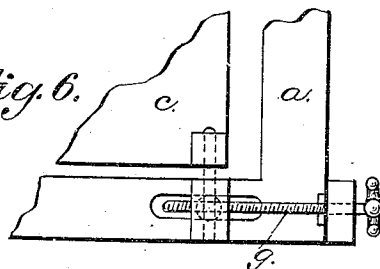
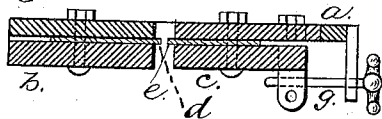

Fig. 7.



Witnesses:

Harry Rohrer.
J. H. Adriaans.

Inventor:

Frederick J. Wooster,
By Parker H. Sweet, Jr.,
Att'y.

UNITED STATES PATENT OFFICE.

FREDERICK J. WOOSTER, OF WATERBURY, CONNECTICUT, ASSIGNOR OF
ONE-HALF TO EDWARD D. STEELE, OF SAME PLACE.

MACHINE FOR SCOURING AND DRYING SHEET METAL.

SPECIFICATION forming part of Letters Patent No. 334,209, dated January 12, 1886.

Application filed May 11, 1885. Serial No. 165,010. (No model.)

To all whom it may concern:

Be it known that I, FREDERICK J. WOOSTER, a citizen of the United States, residing at Waterbury, in the county of New Haven and State of Connecticut, have invented certain new and useful Improvements in Machines for Scouring and Drying Out Sheet Metal; and I do declare the following to be a full, clear, and exact description of the invention, such as will enable others skilled in the art to which it appertains to make and use the same, reference being had to the accompanying drawings, and to the letters and figures of reference marked thereon, which form a part of this specification.

My invention relates to improvements in that class of machines which are designed for scouring and drying out sheet metal, particularly sheet-brass, the object being to remove the scale or other inequalities which accumulate on the surface of said sheet metal during the course of manufacture, to promote the ready removal of the acid used in cleansing said surface, and to aid in the process of finishing said sheet metal in the simplest and best possible manner; and my improvements consist, essentially, in the details of construction and general arrangement of parts, all as will be hereinafter fully described, and specifically designated in the claims.

In the accompanying drawings, Figure 1 represents a side elevation of a machine embodying my invention; Fig. 2, a top plan view of the same with the lid or cover thrown open; Fig. 3, a side elevation of a modification thereof; Fig. 4, a front elevation of the drying-out device; Figs. 5 and 6, detail sectional views of the same, and Fig. 7 a sectional view thereof taken on the line *x x* of Fig. 4.

Similar letters of reference occurring on the several figures indicate like parts.

Referring to the drawings, A represents the box or case of the machine supported upon the legs B, and provided with a hinged lid or cover, C, as shown. Within said box or case A, and near one end, are journaled two horizontally-arranged circular brushes, D D', the one of which has its bearings in the lid or cover C, while the other has its bearings in the bottom of the box or frame A, so that when the lid is closed the two brushes come into juxtaposition to serve as a scouring medium to both

surfaces of the sheet metal which passes between the same, said brushes being revolved in opposite directions to each other by suitable belts or gearing. Upon the front outside end of the box or frame A is secured an adjustable drying-out device, E, through which the sheet metal passes as it enters the box or case A, said device being composed of a rectangular frame, *a*, provided with a stationary gate or cross-frame, *b*, at its upper end, and with an adjustable gate or cross-frame, *c*, at its lower end, the two parts being so arranged with relation to each other as to provide an elongated central slot, *d*, between the two for the passage of the sheet metal, the edges of both gates or cross-frames at this point having a projecting strip of rubber or other suitable elastic material, *e*, which closely impinges upon the upper and lower surface of the sheet of metal as it passes into the machine, to clean or dry off the acid from said metal sheet previous to its entering the box or case A. The lower gate or cross-frame, *c*, is adjustable, by means of the screw-rods *g* at each end of the frame, to any desired height, so as to increase or decrease the width of the slot *d*, through which the sheet metal passes, thereby enabling the rubber or elastic strips *e* to impinge to a greater or less degree upon the surfaces of the metal sheets, according to the nature or character of the work. Corresponding drying-out devices are arranged upon the rear inside end or other portions of the box or case A, to allow the metallic sheet to emerge from the machine in a finished state, free from the dust contained in said box or case. The ends of the box or frame A are extended so as to provide bearings for the rollers F F', from one of which the metal unwinds as it passes through the machine to be cleaned, and upon the other one of which the finished sheet metal is wound, said rollers being easily removed upon the completion of the work for the substitution of others.

In the operation of my invention the metal sheet passes from the roller upon which it is wound through the slot between the gates or cross-frames into the box or frame A, which is filled with fine sawdust, covering said brushes and the sheet metal, to absorb what little acid or moisture is left upon the surfaces of the sheet metal after it passes the imping-

ing rubber scrapers upon the edges of the gates, said rubber or other elastic scrapers effectually removing the greater part of the acid before the sheet enters the machine. The revolving brushes *D D'* complete the process of thoroughly drying off the sheet metal, which then emerges through the slot between the gates at the opposite end preparatory to being wound upon the roller *F*, the rubber scrapers upon the gates at the front end of the machine serving to brush off the sawdust from the metal sheet before it passes from the machine, thereby keeping the sawdust confined within the box or frame *A*. By means of my improvements the process of finishing the metal sheets is greatly facilitated, with a great saving of the sawdust and labor heretofore employed.

It is obvious that my improvements may be employed with equal effect in connection with the ordinary machine having a series of rollers arranged within the box or case *A*, the said rollers being adapted to act upon both surfaces of the metal sheet as it passes through the machine, as fully shown in Fig. 3, and such use or adaptation is hereby contemplated by me.

Having thus described my invention, I claim as new and useful—

1. The herein-described machine for scouring and drying sheet metal, consisting of the box or case *A*, having suitable supporting-legs, *B*, and hinged lid or cover *C*, and provided with the horizontally-arranged brushes *D D'*, drying-out devices *E*, constructed as described, and the rollers *F F'*, substantially as and for the purpose specified.

2. In combination with an inclosing box or case, *A*, for retaining sawdust, provided with suitable brushes, the drying-off device *E*, composed of the frame *a*, provided with the stationary gate *b*, and adjustable gate *c*, having elastic scraping-edges *e*, substantially as and for the purpose specified.

3. In a machine for scouring and drying sheet metal, the drying-off device *E*, consisting of the rectangular frame *a*, provided with the upper stationary gate, *b*, and lower adjustable gate, *c*, having the edges thereof provided with elastic scrapers, substantially as and for the purpose specified.

In testimony whereof I affix my signature in presence of two witnesses.

FREDERICK J. WOOSTER.

Witnesses:

E. D. STEELE,
D. M. DAVIS.