

W. MILLS.

Improvement in Toy-Guns.

No. 132,171.

Patented Oct. 15, 1872.

Fig - 1.

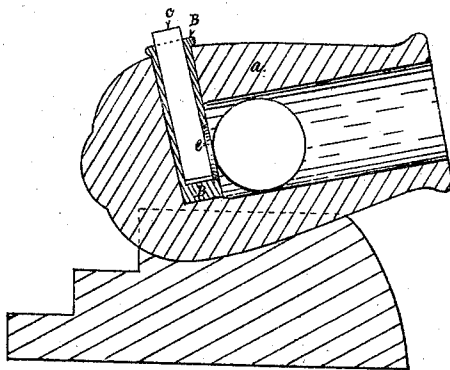

Fig' - 2.

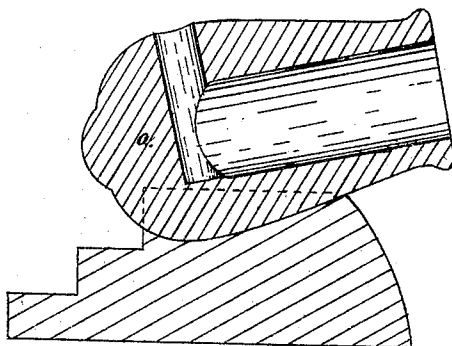

Fig' - 3.

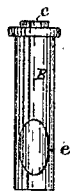

Witnesses

R.R. Moffatt
Arthur Moffatt

Inventor

William Mills

UNITED STATES PATENT OFFICE.

WILLIAM MILLS, OF GREENVILLE, NEW JERSEY.

IMPROVEMENT IN TOY-GUNS.

Specification forming part of Letters Patent No. **132,171**, dated October 15, 1872.

To all whom it may concern:

Be it known that I, WILLIAM MILLS, of the town of Greenville, county of Hudson and State of New Jersey, have invented certain Improvements in Toy-Guns, of which the following is a specification, reference being had to the accompanying drawing which forms a part of the same.

The nature of this invention consists in a novel method of constructing a "toy-gun" so as to shoot a projectile from its bore by means of a primed wafer of fulminate or other detonating compound, which is ignited by means of a metallic pin at the breech-end.

In the accompanying drawing, Figure 1 represents a longitudinal central section of a toy-gun embodying my invention; Fig. 2 is the same, with the metallic charge chamber or tube removed; and Fig. 3 represents the metallic tube or charge chamber detached from the gun.

Similar letters of reference in the several figures indicate like parts.

A represents the gun or mortar, which is made of hard wood. B represents a metallic tube or hollow cylinder, having one end closed and an opening, *e*, in its side near its closed end, (see Fig. 3.) *c* represents a metallic pin or rod, which fits loosely in the hollow cylinder B, and is intended to ignite a small wafer primed with fulminate, which is used as the charge in firing the projectile from the gun.

If desired, the gun with its carriage may be made of cast metal; then it will not be necessary to use the hollow tube B; or, if desired, the gun may be made of hard wood and used

without the hollow tube B. In either case the primed wafer is forced down into the chamber of the gun into place by the pin or rod *c*, which is also used to ignite the charge-wafer. The chamber of the bore is so constructed that an open space remains between the wafer or charge and the projectile.

The operation of my improved toy-gun is as follows: A paper wafer containing a small quantity of fulminate or detonating powder is inserted in the gun as the propelling-charge. If the firing-tube B is used the primed wafer is inserted in the said tube, and then the tube is inserted in the gun, as represented in Fig. 1 of the drawing. The firing-pin *c* is then placed upon the primed wafer and a ball or other projectile is placed in the bore; the gun is then ready to be fired, which is done by striking the pin *c* a sharp blow with a small hammer which ignites the fulminate in the wafer, and as the gases escape into the air-chamber it expands the air suddenly, and thus forces the projectile out of the bore of the gun with a loud report.

Having thus described the construction and operation of my invention, what I claim as new, and desire to secure by Letters Patent, is—

The gun A, in combination with the firing-pin *c* and the primed-wafer charge-chamber, all constructed substantially as and for the purpose herein specified.

WILLIAM MILLS.

Witnesses:

R. R. MOFFATT,
EDWARD MACKINLEY.