

(No Model.)

2 Sheets—Sheet 1.

G. SCHMITT.
BARREL PITCHING APPARATUS.

No. 526,660.

Patented Sept. 25, 1894.

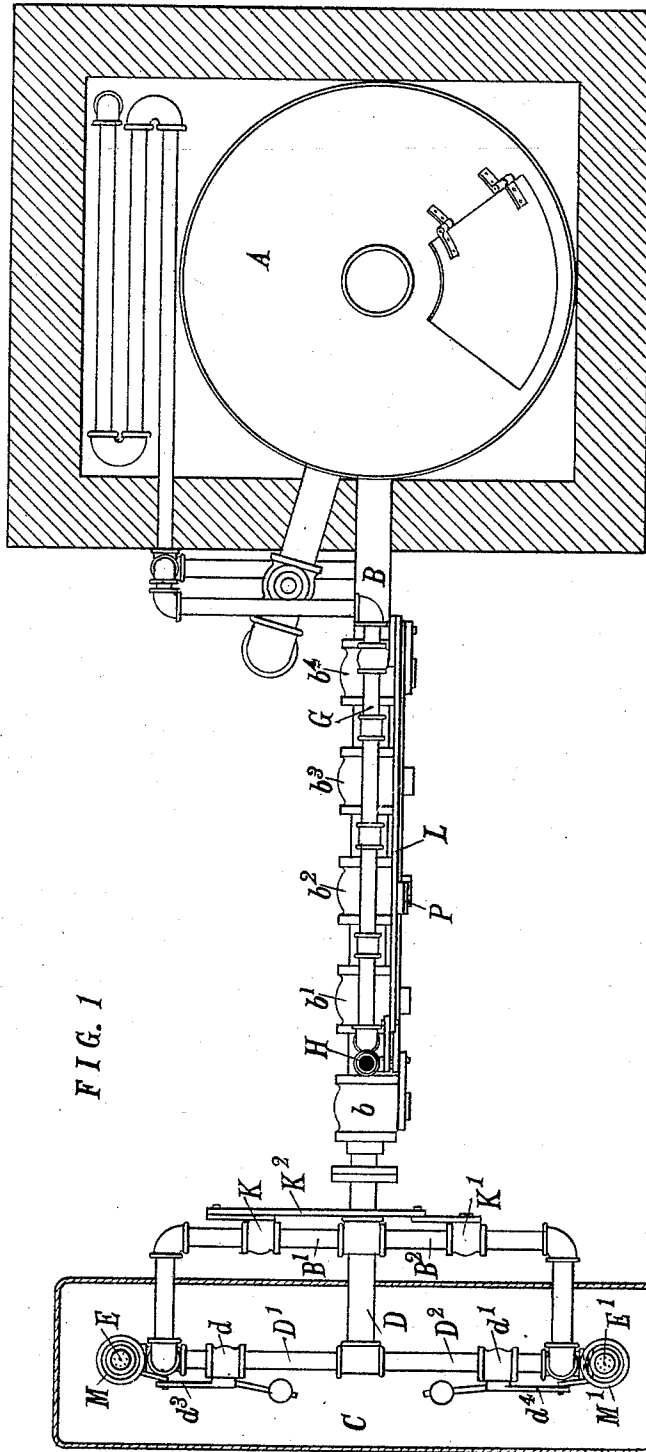

WITNESSES.

Frank. Miller.
M. S. Ingham.

Inventor George Schmitt, by King & Shuster his attys

(No Model.)

2 Sheets—Sheet 2.

G. SCHMITT. BARREL PITCHING APPARATUS.

No. 526,660.

Patented Sept. 25, 1894.

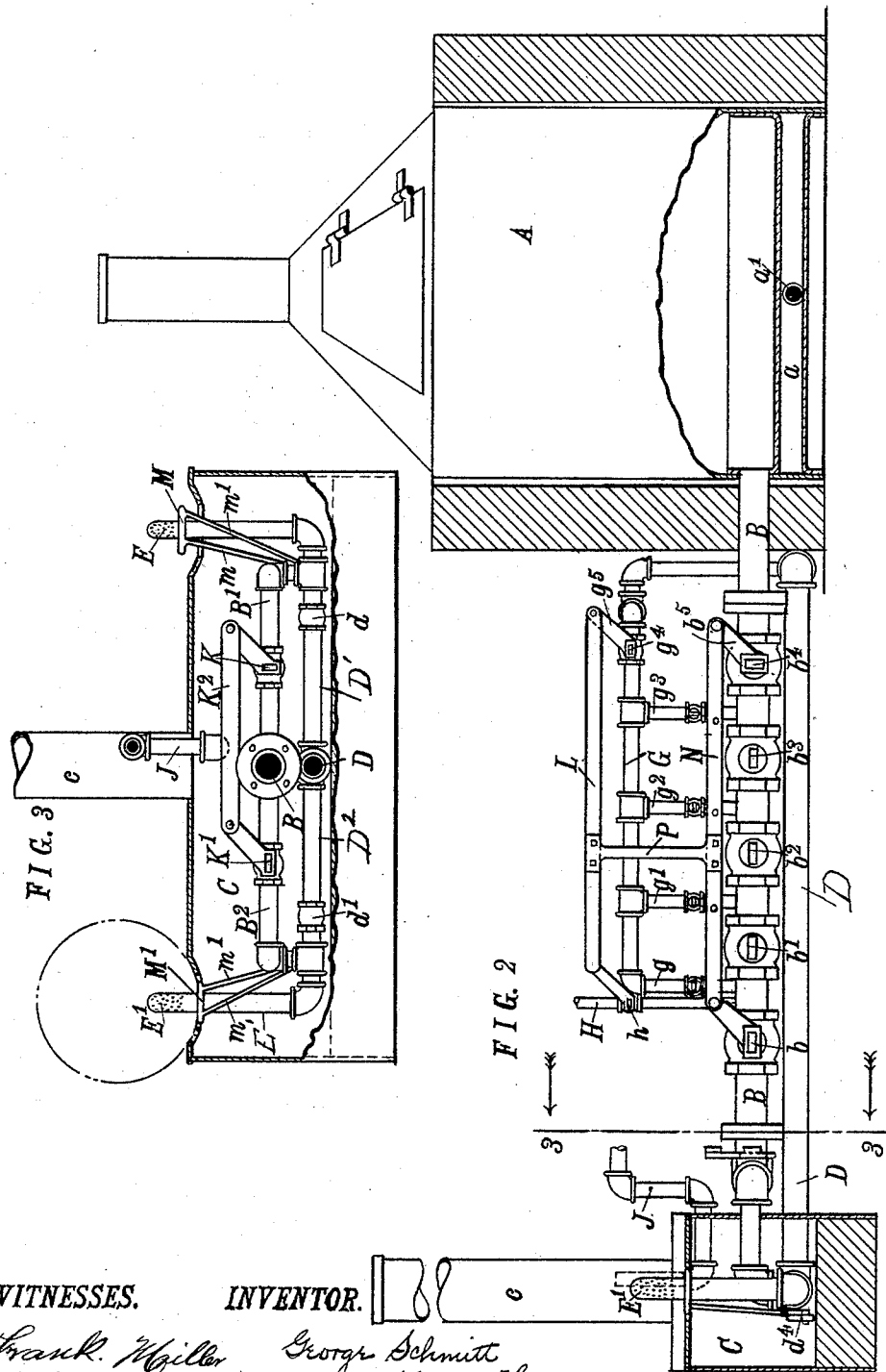

WITNESSES.

INVENTOR.

Frank Miller
M. S. Ingham.

George Schmitt
By King & Thurston
his attorneys

UNITED STATES PATENT OFFICE.

GEORGE SCHMITT, OF CLEVELAND, OHIO, ASSIGNOR, BY DIRECT AND MESNE ASSIGNMENTS, TO PHILIP SHERRER AND MARY A. SHORT, OF SAME PLACE.

BARREL-PITCHING APPARATUS.

SPECIFICATION forming part of Letters Patent No. 526,660, dated September 25, 1894.

Application filed September 27, 1892. Renewed May 10, 1894. Serial No. 510,804. (No model.)

To all whom it may concern:

Be it known that I, GEORGE SCHMITT, a subject of the German Emperor, residing at Cleveland, in the county of Cuyahoga and State of Ohio, have invented certain new and useful Improvements in Barrel-Pitching Apparatus; and I do hereby declare the following to be a full, clear, and exact description of the invention, such as will enable others skilled in the art to which it appertains to make and use the same.

My invention relates to mechanism for mechanically applying pitch or similar material to the insides of barrels, kegs, &c.

The object is to provide a suitable apparatus with which a regulated supply of pitch suitable to the size of the barrel may be applied evenly and quickly to barrels of any size; and my invention consists in the construction and combination of parts hereinafter described and pointed out definitely in the claims.

The best embodiment of my invention at present known to me is that shown in the drawings, in which—

Figure 1 is a plan view of my apparatus, the furnace being in section. Fig. 2 is a side elevation partly in section; and Fig. 3 is a sectional view on line 3—3, of Fig. 2 a part of the ventilator box being broken away to show the arrangement of parts therein.

Referring to the parts by letters, A represents the kettle in which the pitch is melted. It is inclosed by suitable furnace walls and may be heated in any suitable manner, as for example by steam which is discharged into the chamber *a*, beneath the kettle, from the steam pipe *a'* as shown in Fig. 2.

Leading from the kettle A is a pipe B, in which are arranged at suitable intervals the valves *b b' b² b³* and *b⁴*. In front of the valves the pipe B branches to right and left into two pipes B' B² which pipes are provided with valves K K'. The pipes B' B² are turned forward and enter the ventilating box C where they are connected by T couplings to the pipes D' D² respectively. At the ends of the pipes D' D² are the vertical pipes E E' which pass out through the top of the ventilating box C,—the upper ends of the pipes E E' being

perforated for the purpose of producing a spray from any liquid which is forced through the perforations.

D represents a steam-pipe through which super-heated steam (supplied from any suitable source) flows to the outlet points, viz:—the perforations in pipes E E'. The pipes D' D² are branches of the steam pipe D and are provided with valves *d d'* respectively.

G represents a second steam-pipe arranged above the pipe B, and connected therewith by four branches *g g' g² g³*, which are connected with the pipe B in front of the several valves *b' b² b³ b⁴*. The branches *g g' g² g³* are each provided with a valve by means of which communication with the pipe B may be made or closed. The pipe G is also provided with a valve *g⁴* between the source of steam and the first branch pipe *g³*.

H represents a vent pipe connected with the pipe B just behind the valve *b* therein; and this pipe is also provided with a valve *h*. An arm on the valve *h* is connected with an arm *g⁵* on the valve *g⁴* by a bar L, whereby both valves are simultaneously operated,—the valve *h* being opened when the valve *g⁴* is closed, and vice versa.

Surrounding the perforated pipes E E' are the rings M M' which normally lie above the level of the ventilating box. One of these rings is secured to the top of the braces *m m'* which are secured at their lower ends to one arm of the lever *d³*,—which lever is secured to the stem of valve *d*,—the other arm of said lever being counterweighted. The other ring is secured in like manner to a similar lever *d⁴* which is secured to the stem of the valve *d'*.

Leading upward from the center of the ventilating box is a ventilating pipe *c* into which steam is discharged from the pipe J to create a forced draft.

The valves K K' are connected together so that as one is opened the other is closed. This connection is made by means of the bar K² which is secured to the arms on the stem of said valves.

In the operation of the apparatus, the valve *b* is always used, but only one of the other valves *b' b² b³ b⁴*, and which of said valves it

shall be depends upon the size of the barrels to be pitched. For example if a whole barrel is to be pitched, the right hand valve (that is the valve farthest from valve *b*) is used, because
 5 the quantity of pitch which will be contained in the pipe B between the valves *b* and *b*⁴ is the quantity necessary to pitch a whole barrel. If the apparatus is to be used to pitch a half barrel, the next valve *b*³ is operated; for a
 10 quarter barrel the valve *b*² and for an eighth barrel the valve *b*¹. The valves *b*¹ *b*² *b*³ and *b*⁴ are all alike in construction and mode of operation. The lever *b*⁵ may be attached to the stem of either of the valves last referred
 15 to, and when attached to one valve stem, all of the other of these valves are left permanently open. The lever *g*⁵ is connected by the bar L with the lever on the stem of the valve *h* in such manner that both valves must
 20 be simultaneously operated and when one is opened the other is closed. A bar P connects the bar N with the bar L whereby the valves *h* and *g*⁴ are operated simultaneously with the valves *b* and *b*⁴, or *b*³ *b*² or *b*¹ as the case
 25 may be.

In using the apparatus the barrel is laid on the ventilating box, with one of the perforated pipes E E' (say E) entering the bung hole. The weight of the barrel rests on the
 30 ring M, which is thereby depressed. This opens the valve *d* and thereupon super-heated steam from pipe D is admitted to the barrel through the perforations in pipe E, whereby the barrel is dried and heated. The bars L
 35 and N are then moved thereby closing valves *h* and *b*⁴ and opening valves *b* and *g*⁴. Steam enters the pipe B through branch *g*³, thereby forcing out all of the pitch in pipe B in front of the valve *b*⁴ through the pipe B' into the
 40 pipe D' from whence it is forced by the combined action of the steam in the pipes B and B' and the steam in the pipes D and D' into the pipe E (the valve K being open) and discharged in a spray through the perforations.
 45 therein onto the inside of the barrel. While the pitch is being sprayed into the barrel, a second barrel is put on over the pipe E', the valve *d*' is opened and the super-heated steam is admitted to the barrel. When the first
 50 barrel has been pitched, the bars L and N are moved so as to close valves *b* and *g*⁴ and to open valves *b*⁴ and *h*. The pitch from the kettle flows into the pipe B, and the air and steam therein escapes through pipe H. When
 55 the pipe B is filled the bar K² is moved thereby opening valve K' and closing valve K. Then the bars L and N are moved and the pitch in pipe B forced through the pipe B² into the pipe D², thence into the pipe E' and thence
 60 into the second barrel. When a barrel is lifted from the ring on which it rests, the weight on the lever *d*³ or *d*⁴ closes the valve *d* or *d*'.

When it is desired to use the apparatus to
 65 pitch a half barrel the lever is taken from the stem of valve *b*⁴ and attached to the stem

of valve *b*³ and of course properly connected with bar N. The valve *g*² is opened and valves *g* *g*¹ and *g*³ closed. Whichever of the valves *b*¹ *b*² *b*³ or *b*⁴ are placed in connection
 70 with the bar L, determines the amount of pitch which will be used in a barrel. All of the valves *g* *g*¹ *g*² *g*³ except the one immediately in front of the valve *b*, &c., in use must be closed.
 75

Although I have shown in the drawings my device with two spraying pipes and adapted to pitch barrels more rapidly than could be done with one pipe, I do not intend to limit myself to the specific construction shown any
 80 further than is pointed out definitely in the claims, as it is obvious that the device would work similarly whether one or more spraying pipes were used.

Having thus described my invention, what
 85 I claim as new, and desire to secure by Letters Patent, is—

1. In an apparatus for pitching or gluing barrels, in combination, a reservoir, a conveying pipe leading therefrom and having
 90 two valves therein, a steam pipe connected to said conveying pipe between said valves, a valve in said steam pipe, and a perforated pipe connected to said conveying pipe, substantially as and for the purpose specified.
 95

2. In a barrel pitching apparatus, a melting kettle, a pipe B leading therefrom, having the valves *b* *b*⁴, connecting mechanism between said valves whereby either is opened and the other closed simultaneously, a steam
 100 pipe connected to said pipe B in front of valve *b*⁴, a valve in said steam pipe, and a perforated pipe connected with said pipe B, substantially as and for the purpose set forth.

3. In a barrel pitching apparatus, a melting
 105 kettle, a pipe B leading therefrom having a valve *b* and a series of other valves arranged between the valve *b* and the kettle, a steam pipe G, a series of valved branch pipes connecting said steam pipe with the pipe B, and
 110 a perforated pipe E connected with the pipe B, substantially as and for the purpose specified.

4. In a barrel pitching apparatus, a melting
 115 kettle, a pipe B leading therefrom having the valve *b* and a plurality of valves between said valve and the kettle, a steam pipe connected with the pipe B by as many pipes as there are valves between the valve *b* and the kettle, the
 120 two pipes B' B², having valves, and the perforated pipes E E' suitably connected with the pipes B' B² respectively, substantially as and for the purpose set forth.

5. In a barrel pitching apparatus, a melting
 125 kettle, a pipe B leading therefrom having the valve *b* and another valve *b*⁴ between said valve and the kettle, a steam pipe connected with the pipe B just in front of the last named valve, a vent pipe H, valves in said steam pipe and vent pipe, mechanism for simultaneously
 130 closing the valve *b*⁴ and the valve in the vent pipe and opening the valve *b* and the valve in

the steam pipe and vice versa, and a perforated pipe connected with pipe B, substantially as and for the purpose specified.

5 6. In a barrel pitching apparatus, in combination, a steam pipe, a conveying pipe discharging into said steam pipe, a vertical perforated pipe connected with said steam pipe, a valve in said steam pipe, a movable ring surrounding the perforated pipe, and mechanism connecting said ring with said valve, whereby the weight of a barrel resting on said ring opens said valve, substantially as and for the purpose specified.

15 7. In a barrel pitching apparatus, in combination, a steam pipe, a vertical perforated pipe connected therewith, a valve in said steam pipe, a melting kettle, a conveying pipe leading therefrom and discharging into said steam pipe, two valves in said conveying pipe, 20 a second steam pipe connected to said conveying pipe between said valves and a valve in

said second steam pipe, substantially as and for the purpose specified.

8. In a barrel pitching apparatus, in combination, a steam pipe D having the branches 25 D' D², the vertical perforated pipes E E' connected with said branches, valves in each of said branches D' D², a melting kettle, a pipe B leading therefrom having the branches B' B² which are connected respectively with the 30 branch pipes D' D², the valve K K' in said branches B' B², valves b b⁴ in the pipe B, a steam pipe G connected with pipe B and a valve in said pipe G, substantially as and for the purpose set forth. 35

In testimony whereof I affix my signature in presence of two witnesses.

GEORGE SCHMITT.

Witnesses:

E. L. THURSTON,
M. S. INGHAM.