

(No Model.)

5 Sheets—Sheet 1.

E. O. POPPE.
WATER CLOSET.

No. 526,412.

Patented Sept. 25, 1894.

Fig. 1.

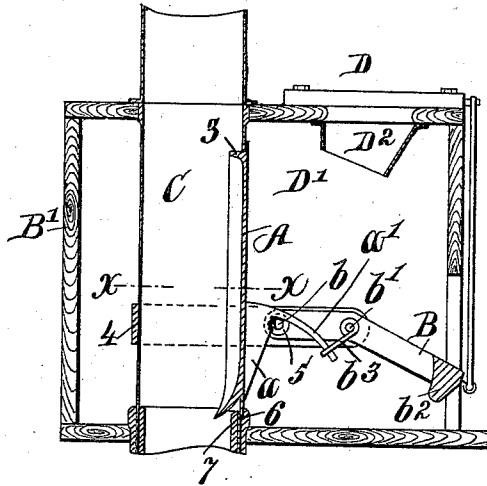

Fig. 2.

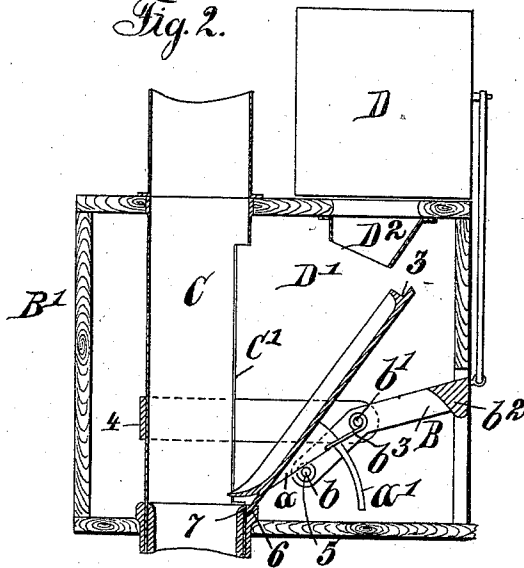
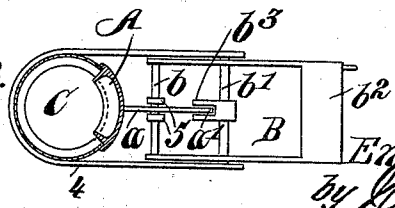

Fig. 3.



Witnesses:
H. E. Dieterich
Henry Orth

Inventor:
Emil Otto Poppe
 by *Henry Orth* Atty

(No Model.)

5 Sheets—Sheet 3.

E. O. POPPE.
WATER CLOSET.

No. 526,412.

Patented Sept. 25, 1894.

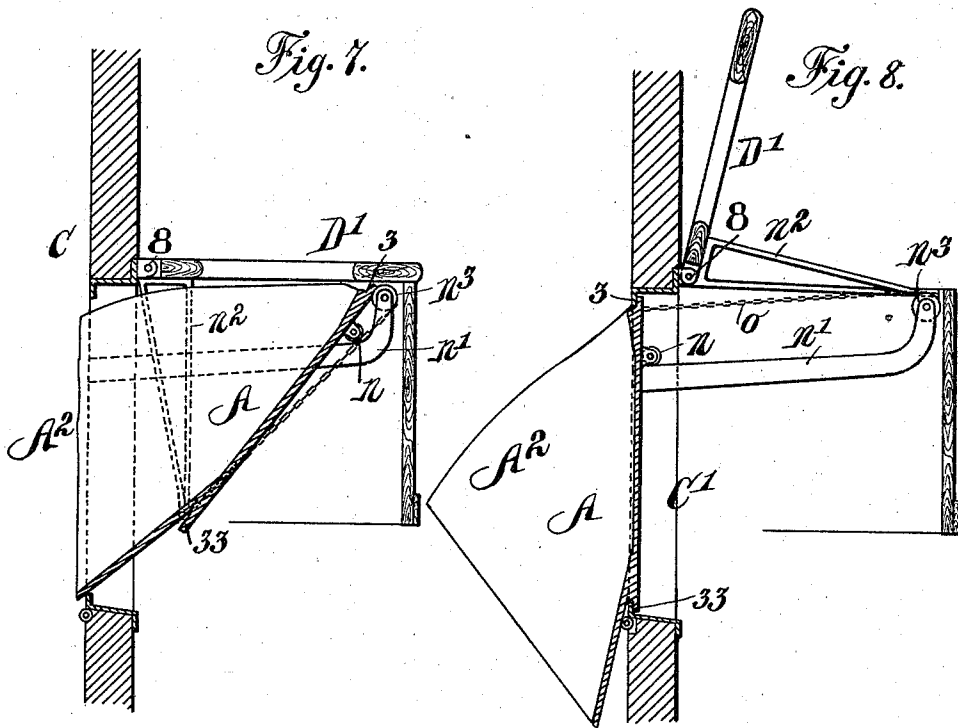

Witnesses
H. G. Vieterich
Henry Orth

Inventor:
Emil Otto Poppe
by Henry Orth
Atty.

(No Model.)

5 Sheets—Sheet 4.

E. O. POPPE
WATER CLOSET.

No. 526,412.

Patented Sept. 25, 1894.

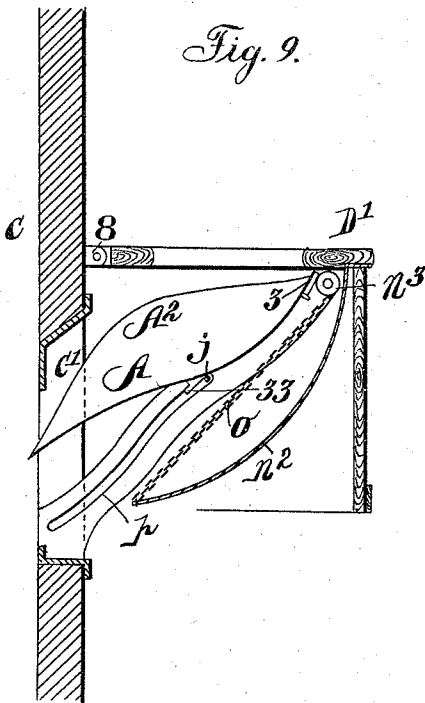

Fig. 9.

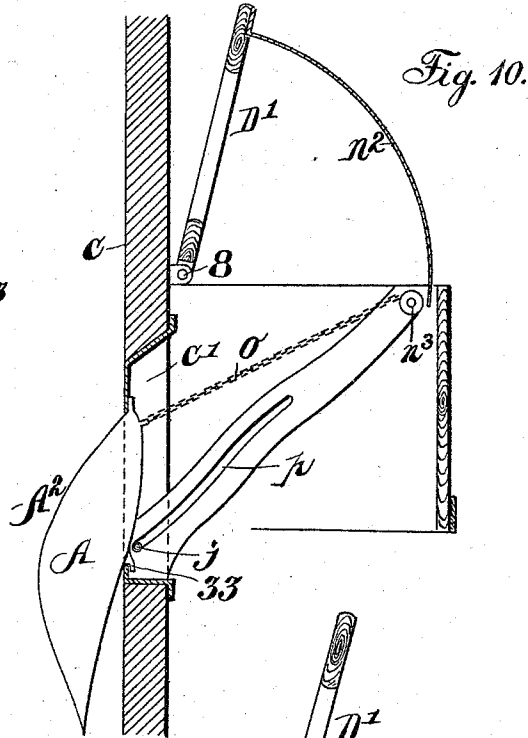

Fig. 10.

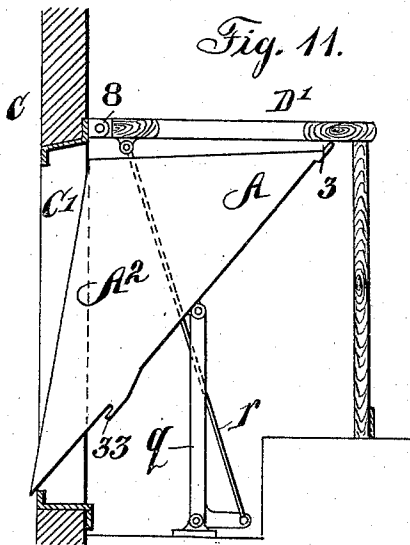

Fig. 11.

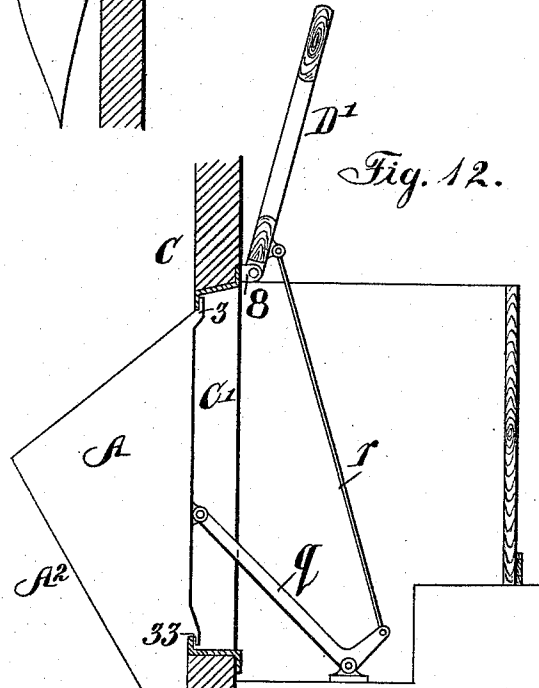

Fig. 12.

Witnesses:
H. E. Nieberich
Henry Orth

Inventor:
Ernst Otto Poppe
 by *Murray* Att'y.

E. O. POPPE.
WATER CLOSET.

No. 526,412.

Patented Sept. 25, 1894.

Fig. 13.

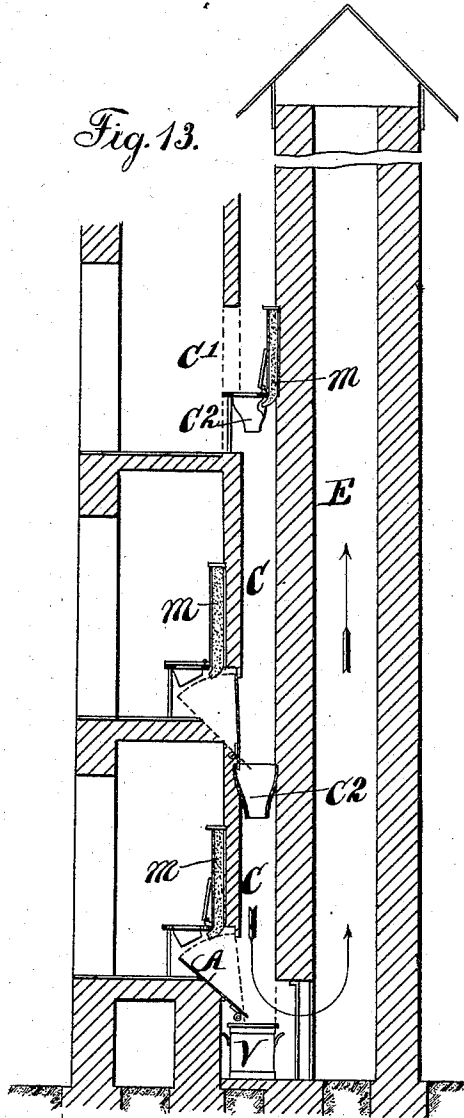

Fig. 15.

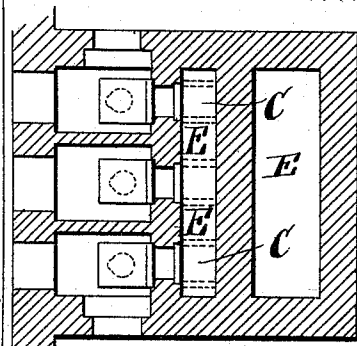
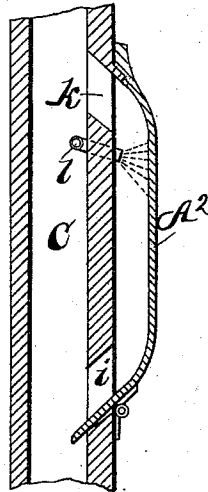

Fig. 14.

Witnesses:
H. G. H. H. H.
Henry Ott

Inventor
Emil Otto Poppe
by Henry Ott Atty

UNITED STATES PATENT OFFICE.

EMIL OTTO POPPE, OF KIRCHBERG, GERMANY.

WATER-CLOSET.

SPECIFICATION forming part of Letters Patent No. 526,412, dated September 25, 1894.

Application filed August 9, 1893. Serial No. 482,728. (No model.) Patented in Germany October 3, 1893, No. 71,313.

To all whom it may concern:

Be it known that I, EMIL OTTO POPPE, a subject of the German Emperor, residing at 242/I, Neumarkt, Kirchberg, Saxony, Germany, have invented certain new and useful Improvements in Water-Closets, (for which I have obtained a patent in Germany, No. 71,313, dated October 3, 1893;) and I do hereby declare the following to be a clear and exact description of the invention.

My invention has relation to water closets, and it has for its principal object the provision of means whereby all communication between the premises and the eduction conduit is effectually cut off when the closet is not in use.

It has for its further object the ventilation of the said conduit or the latter and the receiver for the excrementitious matter; also the provision of means for flushing out the conduit and for deodorizing the excrementitious matter, as will now be fully described, reference being had to the accompanying drawings, in which—

Figures 1 and 2 are sectional elevations illustrating means for cutting off the communication between the closet or premises and the eduction duct for the excrementitious matter, Fig. 1 showing the devices in their relative positions when the closet is not in use, and Fig. 2 showing the same when said closet is in use, and Fig. 3 is a cross-sectional view taken about on line $x-x$ of Fig. 1. Figs. 4 to 12 inclusive are vertical sectional views illustrating modifications in the devices employed for cutting off the communication between the closet or premises and the eduction conduit for the excrementitious matter. Fig. 13 is a vertical sectional elevation of a system of closets for dwellings; Fig. 14, a cross-sectional view thereof, and Fig. 15 a detail view.

Referring to Figs. 1 to 3 inclusive, C indicates the eduction duct for the excrementitious matter, which may be a pipe as shown, extending above the roof of a building and emptying into a sewer pipe or into a vault or other receiver, or said conduit may be a shaft of wood, Figs. 4 and 5, rendered water-proof by any suitable means, or a shaft of masonry, Figs. 7 to 15, coated interiorly with a hydraulic cement smooth troweled and connected with a separate ventilating shaft, as

will hereinafter appear. B' is the closet box, D' the seat, and D the lid for said seat, the latter provided with a directing chute or hopper D².

In that portion of the conduit C within the closet box is formed an opening C' adapted to be hermetically closed by a valve. With a view to reducing the number of the mechanical elements of the closet as much as possible, as well as with a view to avoiding the necessity of flushing or otherwise cleansing the hopper or bowl usually employed in water closets, I so construct the valve as to perform also the function of bowl or receiving and discharging hopper or chute, and will hereinafter call it the chute-valve.

As shown in Figs. 1 to 3, the chute-valve A is constructed in the form of a segmental or longitudinally concavo-convex bowl, the rim which at the rear end is somewhat extended to form a directing lip, as shown at 2, and having an encompassing flange 3 adapted to fit snugly against the outer face of the conduit C and close the opening C' thereof when said chute-valve is in the position shown in Fig. 1, whereby communication between the conduit and the premises through the closet is effectually prevented. I am thus enabled to dispense with the usual more or less ineffectual water sealed bowl, and yet thoroughly protect the premises against contamination by foul or offensive or deleterious gases, this being more completely insured by carrying the conduit a sufficient distance above the roof to induce a continuous upward draft from the sewer connection, vault, or other receiving chamber for the excrementitious matter. Of course a flush tank for flushing the chute-valve A and the conduit may be employed, and as this device and its function are well known I have deemed it unnecessary to show the same, and may state, however, that a stream of water from a flush tank or other source of water supply may be directed onto the chute valve A before it is lifted to close the opening C' or afterward, as may be desired.

The means for operating the chute-valve consist of a fulcrum shaft b' mounted in a strap 4 which may be secured to the conduit C as shown, or to the sides of the closet box B'; of a two-armed weighted lever B, the arms thereof connected at their outer end

with a weight b^2 and at their inner end with a cross rod or shaft b that has preferably two guide collars 5, that serve as guides for an inclined projection a on the under side or back of the chute-valve A, said projection having bearing on the cross rod b of the lever B and being preferably provided with a curved guide arm a' that is guided by a forked arm b^3 on the fulcrum shaft b' . The weight end of the lever B is connected by a rod d with the seat lid D in such manner that when the said lid is lifted the cross rod b will move down the inclined face of the projection a on the back of the chute valve A, and said valve will turn on its fulcrum 6 and move inwardly into the position shown in Fig. 2 on a line with the directing chute or hopper D^2 of the seat. When the seat lid is turned down the weight b^2 will tilt the lever B so that its cross rod b will move upwardly along the inclined face of the projection a on the back of chute valve A and move the latter to its seat on the conduit C. As shown in Figs. 1 and 2, the flange 3 of chute valve A is simply stepped in a gutter or channel 7, the width of which is such as to allow the valve to tilt inwardly the required distance, said valve when tilted back being supported by the cross rod b of lever B.

I have hereinabove described the chute valve A as operated from the seat lid D. It is obvious, however, that the said lever may be connected to the seat D' and the latter hinged to the seat boxing or some other support, and the lid D may be dispensed with, as shown in Figs. 4 to 12 inclusive, the seat being hinged to a cleat or lugs 8 and supported either by a box or housing, or simply by brackets 9, Figs. 4 and 5, according as one or the other is found most convenient, and according to the nature of the eduction conduit C.

The chute valve A, as shown in Figs. 4, 5, and 7 to 12, may be constructed with side walls A^2 , in order to prevent splattering, and it may be hinged to its seat on the eduction duct C, as shown at c in said Figs. 4 and 5, in which arrangement as well as in the arrangement described in reference to Figs. 1, 2, and 3, and in the arrangement shown in Figs. 7 to 12, the said chute valve acts principally as a directing chute to direct the excrementitious matter into the eduction conduit C; but said valve may be constructed to perform the function of a receiving bowl, as shown at A^2 , Fig. 6, the bowl being provided with a seat flange 3 and with a cross bar h^2 that slides in curved and slotted arms h and is pivotally connected to a rod h' and through the latter to the seat D' , the arrangement being such that when the seat is lowered the bowl valve A^2 will be moved under the directing hopper D^2 , and when said seat is lifted said bowl valve will be moved to its seat in the eduction conduit C to empty its contents into said conduit and close the aperture C' thereof, as shown in dotted lines

in said Fig. 6. Furthermore, the chute-valve A may be so constructed as to also perform the function of directing hopper, as shown in Figs. 7 to 12 inclusive, so that the hopper D^2 may be dispensed with. The valve is of the general form of an open-ended scoop, provided with seat flanges 3 and 33. As shown in said Figs. 7 to 12, one of said flanges, namely the flange 33, is of hook form or stands off from the back of the valve and acts at the same time as a support, hooking to the lower part of its seat, as shown in Figs. 8, 10, and 12.

By constructing the valve A of a more or less elliptical form, as shown in Figs. 9 and 10, the opening or valve port C' in the conduit C may be considerably reduced, which is also the case when the valve is constructed as a receiving bowl, as described in reference to and shown in Fig. 6. Finally, various means other than those described in reference to Figs. 1 to 3 and Fig. 6 may be employed for moving the valve A from and to its seat either through the medium of the closet seat lid, or the closet seat, without departing from the nature of my invention. In Figs. 4 and 5 I have shown a bell crank lever, F, the arm f' of which has its outer end bent into a crank that works in a vertical guide slot e' on the back of the valve A, while the arm f^2 of said lever is linked to the closet seat by a rod or link g .

In Figs. 7 and 8 there is a roller n on the back of the valve that travels on a more or less inclined rail n' whose inner end is bent upwardly and carries a chain or cord pulley n^3 for a chain or cord o , one end of which is attached to the upper part of the back of the valve and the other to an arm n^2 secured to the seat D' . It is obvious that when the seat is raised, as shown in Fig. 11, the valve will be on its seat, but when said seat is lowered, the arm n^2 will draw upon the cord, whereby the valve will be lifted as its roller n travels upwardly on the rail n' , and at the same time said valve will be drawn inwardly, so that when the closet seat D' has been moved down for use the valve A will lie immediately under said seat as shown in Fig. 7. A similar result may be obtained by the arrangement of devices shown in Figs. 9 and 10, in which the chute valve A is provided with a journal or journals j extending into the slot of an arm or arms p , on the upper end of which is mounted a roller n^3 for the cord or chain o whose opposite ends are secured to a sweep or curved arm n^2 at the front end of the seat D' and the upper end of the bowl valve A. Finally I have shown in Figs. 11 and 12 a bell crank lever g whose longer arm is pivotally connected with the bowl valve A and whose shorter arm is connected by a rod r with the closet seat D' .

From what has been said it will be seen that a variety of mechanical devices may be employed for seating and unseating the valve A, and that said devices may be operated

either through the medium of the closet seat lid or closet seat, and from the description of the various devices given as examples others will readily suggest themselves to the skilled mechanic.

In Figs. 13 and 14 I have shown a system of closets for buildings, C indicating the education shaft emptying into a receiver which may be a vault or a vessel V in the lower part of the building, the shaft C communicating at its lower end with a separate ventilating shaft E carried above the roof of the building.

In order to avoid as much as possible the projection of excrementitious matter upon and its adhesion to the shaft surfaces, I arrange directing hoppers C² within said shaft below each closet valve A, and if desired a more or less pulverulent absorbent or disinfectant such as are generally used in dry or other closets and contained in a suitable holder or reservoir *m* may be delivered upon the valve A automatically when said valve is unseated and moved into position for use, or this may be effected by hand. Instead of a pulverulent absorbent or disinfectant, water may be sprayed upon the valve from a pipe *l* located within the shaft C, as hereinbefore stated, and as shown in Fig. 15, *i* indicating the discharge port, and *k* a ventilating port in shaft C.

When the closets are arranged in series on the several floors of a building the ventilating shaft E may be constructed adjacent to or between the education shafts C, with a view to economy in space, as shown in dotted lines in Fig. 14, or all of said education shafts C may be connected with a common ventilating shaft E, as shown in full lines in said Fig. 14.

By providing a separate ventilating shaft for the closets the danger of noxious or deleterious gases coming in contact with the body or passing into the building when a closet is in use is substantially avoided, while with the use of disinfectants or absorbents the noxious odors are to a great extent if not altogether destroyed, so that the closets may well be termed inodorous and non-infectious.

Having thus described my invention, what I claim as new therein, and desire to secure by Letters Patent, is—

1. The combination with a vertical soil pipe provided in its wall with ports at different elevations, of a valve for each of said ports constructed to receive excrementitious matter, and adapted to move from and to its port to receive and discharge such matter into the pipe and close the port therein, for the purposes set forth.

2. The combination with a vertical soil pipe provided with a port in its wall and a movable closet seat arranged above said port, of a valve constructed to receive excrementitious matter, adapted to move from and to said port under and from under the seat to receive excrementitious matter and discharge the same into the pipe and close the port therein, said valve adapted to be operated by the closet seat, substantially as and for the purpose set forth.

3. The combination with a vertical soil pipe provided with a port in its wall and a movable closet seat arranged above said port, of a valve, constructed to receive excrementitious matter, adapted to move from and to said port under and from under said seat to receive and discharge such matter into the pipe and close the port therein, and mechanism substantially such as described arranged outside of the pipe, adapted to support the valve and move the same from and to its port, said mechanism connected with and adapted to be operated from the seat, for the purpose set forth.

4. In a water closet, the combination with a soil pipe or conduit, an opening or port therein provided with a valve seat, of a valve constructed to receive excrementitious matter and provided on its back or bottom with seat flanges fitting said valve seat, the rear edge of said valve supported from the lower edge of its valve seat and mechanism substantially such as described adapted to support and move the valve from under the closet seat to its seat in the valve port and vice versa, said mechanism controlled by a movable element of the closet seat, as the lid therefor, for the purpose set forth.

5. In a system of water closets for buildings, a vertical soil pipe or conduit of uniform cross section throughout provided with openings or ports at different elevations, a ventilating pipe or shaft in communication with said conduit at the foot thereof, and a closet seat arranged above each port, in combination with a valve for each of the aforesaid ports constructed to receive excrementitious matter and adapted to move from under the closet seat to its port and vice versa, receive excrementitious matter, discharge the same into the conduit and close the port therein, for the purpose set forth.

In witness whereof I have hereto signed my name in the presence of two witnesses.

EMIL OTTO POPPE.

Witnesses:

BD. BRÜCKNER,
OSCAR GOTTSCHALK.