

(19) **DANMARK**

(10) **DK/EP 3775385 T3**



(12) **Oversættelse af
europæisk patentskrift**

Patent- og
Varemærkestyrelsen

-
- (51) Int.Cl.: **E 01 F 9/529 (2016.01)**
- (45) Oversættelsen bekendtgjort den: **2023-09-18**
- (80) Dato for Den Europæiske Patentmyndigheds bekendtgørelse om meddelelse af patentet: **2023-06-28**
- (86) Europæisk ansøgning nr.: **19775515.0**
- (86) Europæisk indleveringsdag: **2019-03-29**
- (87) Den europæiske ansøgnings publiceringsdag: **2021-02-17**
- (86) International ansøgning nr.: **US2019025035**
- (87) Internationalt publikationsnr.: **WO2019191706**
- (30) Prioritet: **2018-03-30 US 201862650958 P** **2019-01-28 US 201962797894 P**
2019-01-30 US 201962799024 P
- (84) Designerede stater: **AL AT BE BG CH CY CZ DE DK EE ES FI FR GB GR HR HU IE IS IT LI LT LU LV MC MK MT NL NO PL PT RO RS SE SI SK SM TR**
- (73) Patenthaver: **Traffix Devices, Inc., 160 Avenida La Pata, San Clemente, CA 92673, USA**
- (72) Opfinder: **MAUS, Geoffrey B., 160 Avenida La Pata, San Clemente, CA 92673, USA**
ALMANZA, Felipe, 160 Avenida La Pata, San Clemente, CA 92673, USA
JAIME, Christopher A., 160 Avenida La Pata, San Clemente, CA 92673, USA
KULP, Jack H., 160 Avenida La Pata, San Clemente, CA 92673, USA
- (74) Fuldmægtig i Danmark: **NORDIC PATENT SERVICE A/S, Bredgade 30, 1260 København K, Danmark**
- (54) Benævnelse: **MODULOPBYGGET KØRSELSADVARSELSSTRIBESYSTEM**
- (56) Fremdragne publikationer:
EP-A1- 0 388 650
EP-A1- 2 789 745
WO-A1-2010/056142
GB-A- 2 086 967
US-A- 5 295 759
US-A- 5 769 563
US-A1- 2015 376 849
US-A1- 2018 099 647
US-B1- 6 174 103
US-B1- 6 309 137
US-B1- 9 783 941
US-B2- 7 591 605
US-B2- 9 382 937
"Traffix Alert Rumble Strips", YOUTUBE VIDEO, 25 February 2013 (2013-02-25), XP054979887, Retrieved from the Internet: URL:<https://www.youtube.com/watch?v=FA160I0UM24>

Fortsættes ...

DESCRIPTION

Background of the Invention

[0001] Warning or, more popularly, rumble strips are well known in the highway industry, particularly for high speed highway applications in order to provide an easily detectable noise and vibration, when driven over. They are typically used to warn approaching drivers of a hazard ahead, such as a toll booth, the end of a freeway, a sharp curve, or the like. Permanent rumble strips are placed in the pavement of the roadway for such permanent hazards as are described above. In other circumstances, where the hazard is temporary, such as a construction zone, vehicular accident, checkpoint, or the like, temporary rumble strips may be useful. Such a temporary rumble strip system is disclosed in U.S. Patent No. 7,736,087 to Mettler et al. Another example of a temporary highway warning system is disclosed in U.S. Patent No. 5,769,563 to Flynn.

Summary of the Invention

[0002] The invention described herein is a portable rumble or warning strip system which has a number of advantages compared to prior art systems of the type. One such advantage is that the system can be produced at a significantly lower cost, because of improved molding techniques and the ability to utilize recycled and lower cost rubber materials. This advantage, of course, affords a significant environmental benefit compared to prior art products molded of relatively expensive polyurethane. Other advantages include greater ease of assembly and disassembly, availability in a variety of colors, a carrying handle for ease of transport, stacking lugs for easy stackability of multiple modules, jigsaw style connections for maximum assembly options, and lengthwise metallic cables to offer stability and additional weight.

[0003] More particularly, there is provided a modular highway warning strip system, comprising a plurality of segments assembled together to form a warning strip assembly having a length, each of the plurality of segments being spaced from adjacent ones of the segments along the warning strip length, the segments being assembled together along a cord disposed along the length of the warning strip assembly, the warning strip assembly comprising a first warning strip subassembly and a second warning strip subassembly which are joined together by engagement of a first jigsaw member on an end of the first warning strip subassembly and a second jigsaw member on an end of the second warning strip subassembly. A plurality of spacers may be disposed on the cord along the length of the warning strip assembly, each of the plurality of spacers being disposed between adjacent ones of the segments in order to maintain a spacing between each adjacent segment. Each of the spacers may comprise a hollow structure sized to be disposed about the cord, such as a tube, formed of a corrosion-resistant material.

[0004] Each of the plurality of segments may comprise an opening disposed therethrough for receiving the cord, and in exemplary embodiments, may also comprise a second opening disposed through each of the plurality of segments for also receiving the cord. The cord may exit from one of the openings in an endmost segment on a first end of the warning strip assembly, may extend in an arc toward the second opening on the endmost segment, and may enter the second opening, thereby forming a handle loop on the first end of the warning strip assembly. Again, in exemplary embodiments, the cord further extends through the second opening in each of the assembled segments, exits from the second opening in an endmost segment on a second end of the warning strip assembly, extends in an arc toward the other opening on the second end endmost segment, and enters the other opening, thereby forming a second handle loop on the second end of the warning strip assembly.

[0005] Being able to separately manipulate lighter and easier-to-handle subassemblies, and then to join them together after placement in a roadway, makes installation easier. Each of the first and second jigsaw members may comprise a straight edge and an opposing jigsaw edge, the jigsaw edge of each of the first and second jigsaw members comprising a series of protrusions and concavities which are adapted to engage with the jigsaw edge of the other jigsaw member, such that when the first and second jigsaw members are joined together by engagement of their respective jigsaw edges, a jigsaw segment is formed. In the exemplary embodiments, the first and second jigsaw members are substantially identical in construction.

[0006] Advantageously, some or all the surfaces of each segment are covered with a protective material, such as urethane.

[0007] Another advantageous feature of the invention is that one or more of the plurality of segments may be of a darker color and one or more of the plurality of segments may be of a lighter color. The lighter colored segments and the darker colored segments can be assembled in alternating fashion to improve visibility to approaching motorists. Additionally, alternating ones of the plurality of segments may be formed of different materials. For example, some of the segments may be formed of steel and others of the segments may be formed of aluminum, both for purposes of creating the aforementioned color contrast as well as to lighten the weight of the assembly.

[0008] The invention, together with additional features and advantages thereof, may best be understood by reference to the following description taken in conjunction with the accompanying illustrative drawings.

Brief Description of the Drawings

[0009]

Fig. 1 is an isometric view of a modular warning strip segment;

Fig. 2 is a view similar to that of Fig. 1, wherein hidden lines are shown in order to reveal the internal construction of the segment;

Fig. 3 is an isometric view similar to Figs. 1 and 2 illustrating a steel cable mat which forms a part of the warning strip segment apart from the molded segment;

Fig. 4 is a top view of the modular warning strip segment of Fig. 1;

Fig. 5 is a top view similar to Fig. 4, of the modular warning segment as it is shown in Fig. 2, with hidden lines shown for clarity;

Fig. 6 is a side view of the warning segment of Figs. 1 and 4;

Fig. 7 is an end view of the warning segment of Figs. 1 and 4;

Fig. 8 illustrates three modular warning segments which have been joined together in end-to-end fashion;

Fig. 9 is a view similar to Fig. 8 illustrating another exemplary option for joining the modular warning segments together in an offset relationship;

Fig. 10 illustrates another exemplary embodiment of the modular warning segments which have been constructed in a sandwich fashion for the purpose of having multiple colors;

Fig. 11 is another view of a modular warning segment having a sandwich construction;

Fig. 12 is yet another view of a modular warning segment having a sandwich construction;

Fig. 13 is still another view of a modular warning segment having a sandwich construction;

Fig. 14 is a top view of another exemplary modified embodiment of a modular warning strip segment;

Fig. 15 is a top view of a metallic plate, preferably of steel, for providing internal support for the modular warning strip segment of Fig. 14;

Fig. 16 is an end view of the metallic plate of Fig. 15;

Fig. 17 is a detail view of the portion A of Fig. 16;

Fig. 18 is an isometric view of a metallic plate similar to that shown in Figs. 15-17;

Fig. 19 is a top view of the embodiment shown in Fig. 15 with the metallic plate visible for clarity as to the construction of the warning segment assembly;

Fig. 20 illustrates an assembly of three modular warning strip segments of the type shown in Figs. 15-19 joined end-to-end in a manner similar to the segments shown in Fig. 8;

Fig. 21 is an isometric view of an exemplary embodiment of an inventive modular warning strip segment assembly according to the principles of the present invention;

Fig. 22 is an isometric view of a portion of the center section of the warning strip segment assembly shown in Fig. 21;

Fig. 23 is an isometric view of one of the end sections of the warning strip segment assembly shown in Fig. 21;

Fig. 24 is an isometric view of a section of a warning strip segment similar to end segments shown in the embodiment of Figs. 21-23, with additional unique features;

Fig. 25 is a schematic cross-sectional view of the warning strip segment shown in Fig. 24;

Fig. 26 is an isometric view of a warning strip segment assembly constructed using a plurality of the warning strip segments shown in any of the Figs. 21-25;

Figs. 27-29 illustrate warning strip systems assembled by joining a plurality of joinable partial warning strip assemblies; and

Fig. 30 is an isometric view of another exemplary modified embodiment of the inventive warning strip segment assembly.

Description of the Invention

[0010] Referring now more particularly to the drawings, there is shown in Figs. 1-6 one exemplary embodiment of a modular warning strip segment or traffic control bump 10 that is not according to the invention and is present for illustration purposes only. The traffic control bump 10 has a first end 12 and a second end 14, wherein each end comprises male protrusions 16 and female receptacles 18 adapted for joining adjacent opposed ends of similar segments 10 for the purpose of configuring a desired warning strip configuration. The segment 10 in the illustrated embodiment is comprised of rubber. The rubber may be, preferably, recycled rubber. Generally, the color of the material forming the segment is black, but other colors may be utilized, such as orange and white, and variations, such as using yellow portions along each lengthwise side, may be utilized. A handle 20 is formed in the segment for convenient transport. The handle 20 is preferably large enough to accommodate a gloved hand. Male stacking lugs 22, with corresponding female recesses (not shown) in the underside surface of the segment 10, may be formed on each end, if desired, but are not required. Also, of course, the location of the stacking lugs and corresponding female recesses along the top and bottom surfaces of the segment 10 may vary as desired. Each lengthwise side of the segment 10 comprises a downwardly ramped portion 24, to a thinner profile compared to the full thickness of the center portion of the segment, to assist traversal over the segments. The bidirectional ramp feature eliminates the issue of orientation of the segment on the roadway. In the illustrated embodiments, the ramps 24 are sloped at an angle of approximately 10-15 degrees, though that angle may be varied if desired. Advantageously, the jigsaw ends of each segment may also function as a handle if desired.

[0011] In one particular embodiment, the full thickness of each segment is about 3.81 cm (1 ½ inches), and each segment 10 is about 1.17 to 1.18 m (46 to 46 ½ inches) in length. The width of each segment is about 0.30 m (12 inches) in some embodiments and about 0.33 m (13 inches) in others. Other embodiments may employ varying thicknesses, such as about 2.54 cm (1 inch) or about 1.91 cm (0.75 inches). Each segment may weigh between about 10.9 and 18.1 kg (24 and 40 lb). Joining three segments 10 together, as shown in Figs. 8 and 9, will create a warning strip which covers approximately the width of one typical roadway travel lane of 3.35 to 3.66 m (11 to 12 feet). The dimensions discussed throughout this application are representative only - variations are possible and even desirable, depending upon particular application.

[0012] Figs. 10-13 illustrate a unique alternative sandwich construction for the segments 10 not according to the invention and present for illustration purposes only, to permit production of segments 10 in multiple colors. The segment 10 is made as a sandwich. As shown in Fig. 11, a thin layer 25a of colored vulcanizable rubber is laid into a mold, after which a second layer 25b of inexpensive black vulcanizable rubber is laid on top of the first layer. Then, a third thin layer 25c of colored vulcanizable rubber is laid on top of the second black layer 25b. This sandwich is then pressed and vulcanized into a finished part. Externally, the finished part has the appearance of a solid colored part, with the exception of the parting line 26 as shown, for example, in Fig. 12. An advantage of this approach is that the part is much less expensive to produce, as the black core rubber is much less expensive. The core rubber does not need to be U.V. stabilized, or have other expensive additives, as it is inside the protective shell of the colored outer layers.

[0013] As noted above, Figs. 8 and 9 illustrate two exemplary approaches for deploying the modular warning segments 10 to create a rumble or warning strip assembly 28 or 30, respectively. In Fig. 8, the assembly 28 is merely three segments 10 joined end-to-end using the respective male protrusions 16 and female receptacles 18, respectively, wherein male protrusions 16 on one end of a segment 10 are inserted into corresponding female receptacles 18 on the opposing end of an adjacent segment 10, the female receptacles 18 being open, so that the engagement of the male protrusions 16 into corresponding female receptacles 18 is in the fashion of the joining together of jigsaw puzzle pieces. Accordingly, a flush engagement of the opposing segment ends is created, as shown. On the other hand, Fig. 9 illustrates one example of the versatility of the system, in that the segments 10 are designed for offset joiner as well, in either offset direction, because any male protrusion 16 is adapted for flush engagement with any female receptacle 18. This versatility allows for the creation of warning strip assemblies having a great number of different orientations, thereby maximizing the functionality of the system. As shown in Fig. 9, by offsetting the connections between adjacent segments 10, a warning strip assembly 30 has a total width of approximately 55.9 cm (22 inches) in the illustrated example, rather than the width of warning strip assembly 28, which is limited to the width of a single segment 10, or about 30.5 cm (12 inches) in the illustrated embodiment. In other words, each segment 10 is offset about 12.7 cm (5 inches) relative to adjacent segments, when joined in the illustrated offset manner. However, the total length of

the assembly remains the same as for the Fig. 8 assembly 28 - approximately 3.42 m (11 ft, 2 ½ inches) in one representative embodiment.

[0014] Although the segments 10 may simply be comprised of molded rubber, preferably recycled rubber, or of a sandwich construction, as shown in Figs. 10-13, a particularly advantageous embodiment is illustrated in Figs. 2, 3, and 5. Applicant has discovered that it is particularly beneficial to mold the segment 10 to include a plurality of metallic cables 32 running lengthwise within the segment. As shown in Fig. 3, these cables 32 may be formed as a single cable mat 34, preferably formed of corrosion-resistant steel cables 32, though the cable material may be varied depending upon application. The mat 34 is molded together with a molded rubber segment 36, such as vulcanized rubber, to form the segment 10 shown in Fig. 2.

[0015] Notably, as shown, some of the cables 32a forming the cable mat 34 have an extended length so that they extend into the male protrusions 16 on both ends of the segment 10, once the cable mat 34 is molded into the rubber mat 36.

[0016] Advantageously, the steel cables 32, 32a running lengthwise along the segments 10 provide added weight for each segment 10, which allows for the use of less rubber to make the segment, thereby saving cost and bulk. More significantly, the cables function to substantially stiffen and strengthen the projections 16 to significantly improve the connection between adjacent segments 10, as well as strengthening the ramps 24 on each side of the segment.

[0017] Referring now to Figs. 14-19, there is shown in these figures a modified embodiment of a modular warning strip segment 10 that is not according to the invention and is present for illustration purposes only. In connection with these figures, like elements will be identified by like reference numerals to those used in connection with Figs. 1-13. In this embodiment, rather than using the cables 32, 32a to reinforce the rubber segment 10, a segmented metallic plate 38 is utilized (Figs. 15-19). The plate 38, preferably fabricated of steel, adds critical ballast weight of about 14.5 kg (32 lb). Including about 5.44 kg (12 lb) of rubber encasing the steel plate, the combined weight of the entire assembly 10 is about 20 kg (44 lb.), in one particular embodiment. Of course, size and weight of the foregoing described parts may change within the scope of the system, depending upon application.

[0018] As shown in Fig. 15, the segmented plate 38 is formed of a plurality of segments or ballast blocks 40 separated from one another by living hinges 42, and is, in one embodiment, about 22.9 cm (9 inches) wide. In one embodiment, each block 40 is about 10.2 cm (4 inches) long and about 7.62 cm (3 inches) wide. These living hinges 42 comprise slits or slits made in the surface of the metallic plate 38, both lengthwise and widthwise in a grid, which are preferably laser-cut, though other suitable scoring methods may be used as well. The slits or living hinges 42, are .005 - 1/16 in. in width, in certain embodiments. The plate 38 has two lengthwise edges 44. In certain embodiments, the slits 42 extend entirely through the thickness of the plate 38, except for a plurality of lands of metal extending across the width of the slit 42 from one segment 40 to the next, in spaced relationship along the length of the particular slit

42, which may be of either a reduced thickness or of the full thickness of the plate 38. In other embodiments, the slits 42 may only extend through a partial thickness of the plate 38, though the depth of the slit must be sufficient to permit adjacent segments or blocks 38 to flex and bend relative to one another.

[0019] In one particular embodiment, there are twenty-eight ballast blocks 40, though, of course, this number can vary. The grid of living hinges 42, coupled with the lengthwise edges 44 of the plate 38, together define the twenty-eight ballast blocks 40, as shown in Figs. 15, 18, and 19. As a result, each of the inside blocks 40 is defined on all four sides thereof by a living hinge 42, and the outside blocks 40 are defined by a living hinge 42 on three sides, and by the plate outside edge 44 on its remaining side.

[0020] The living hinges 42 create an extremely desirable field performance feature, which is closely spaced and controlled flexibility both axially and transversely for the warning strip segment 10 as a whole. This flexibility enables the segment 10 to easily conform to any unknown surface irregularity, which is common when dealing with uneven, potholed, or crowned road surfaces upon which the segment 10 is likely to sit when in use.

[0021] The segmented plate 38, with the individually created ballast blocks or segments 40, permits separate flexibility of individual ballast segments, one relative to another adjacent one, or groups of blocks relative to adjacent groups of blocks, in either an axial or transverse direction, while maintaining their as-manufactured, physical spacing and as-molded physical relationship to one another.

[0022] A hole 46 is drilled or otherwise created, using known fabrication techniques, in each ballast block or segment 40, as shown in Figs. 15, 18, and 19. One or more additional such holes 46 may be formed in a center portion 48 of the plate 38. One such hole 46 is illustrated in Fig. 15, while three holes 46 are illustrated in the center portion 48 in Figs. 18 or 19 - either arrangement is within the scope of the example, as well as any other desired number of such holes 46. Holes 46 are also illustrated in each of the end portions 16 and 18. It is not required that there be a hole 46 in every segment 40, or in the center portion 48, or in the end portions 16, 18, but there should be a sufficient number of holes 46 spaced across the surface of the plate 38 to ensure the function described for the holes 46 below. In one embodiment, the diameter of each hole 46 is 1.91 cm ($\frac{3}{4}$ inch), but the size may be adjusted as desired to suit application and preferences as long as functionality is maintained. A handle hole 20 is also formed in the center region 48, in order to ensure that the finished segment includes such a handle 20. The plate 38 also includes a male protrusion 16 formed at a first end and a female receptacle 18 formed at the second end thereof, in order to ensure that the finished molded segment assembly 10 will include those features.

[0023] Now, a method for compression molding and fabricating a modular warning strip segment not according to the invention and present for illustration purposes only will be described, in conjunction with the embodiment illustrated in Figs. 14-20. Initially, one slab or layer of vulcanizable rubber is first laid into the top of the mold (the part is molded upside-

down), over three locating pins which will protrude through the top surface of the rubber layer. The three locating pins are used to locate and precisely position the segmented metal plate 38 within the open mold, atop the initial rubber layer, the locating pins extending through locating pin holes 51 in the plate 38. Once the segmented ballast plate 38 is positioned on the three locating pins protruding through the slab or layer of rubber already placed in the mold, the tool is ready for the final step prior to molding.

[0024] Atop the first slab of rubber and the segmented steel plate 38, positioned in the mold on its three standoff pins, a second layer of vulcanizable rubber is laid. At this point, the mold is ready to be closed, with the segmented steel plate 38 sandwiched in the middle of the molded product, between the two rubber layers. In one particular embodiment, the plate 38 is about 7.94 mm (5/16 inches) thick, while each of the two rubber layers are about 6.35 mm (¼ inch) thick, though these dimensions may be modified to a certain extent, depending upon design considerations.

[0025] When the mold is closed, and the rubber is heated in the pre-heated press, the vulcanizable rubber comprising each of the two rubber layers becomes a viscous fluid. Under the tremendous pressure of the compression molding press, the molten rubber flows through the formed holes 46 in the metal plate 38. This process creates what is essentially a rubber bolt extending through each of the holes between the upper rubber layer and the lower rubber layer of the finished assembly, which ensures the stability and position of each of the three layers, relative to one another, since each of the layers and the plate are linked.

[0026] The free flowing rubber also will extrude itself into and through (if the slit 42 extends through the entire thickness of the plate 38) each of the 1.59 mm (1/16 inch) wide laser cut spaces or living hinges 42 between each ballast block 40, thereby creating a vulcanized rubber living hinge 42.

[0027] Fig. 19 illustrates a partially completed warning strip segment 10, with the top layer of rubber removed for illustrative purposes, in order to show how the metal plate 38 is situated within the assembly 10. Thus, lower rubber layer 50 is illustrated, with the metal plate 38 situated within that layer 50, as shown. The aforementioned rubber bolts fill each of the holes 46 to secure the layers and the plate together.

[0028] Figs. 14 and 20 illustrate a completed, molded warning strip segment 10. In these figures, the upper rubber layer 52 is shown, sandwiching the metal plate 38 between itself and the lower rubber layer 38. The top surface of the upper rubber layer 52 is substantially smooth in order to prevent injury to motorcyclists and other two-wheeled vehicles which may travel over the strip, with only optional molded traction bumps 54 disposed thereon. An information block 56 is provided, in the event it is desired to mold information therein, such as company name, contact information, model information, or the like. As shown in Fig. 20, any number of warning strip segments 10 may be joined end-to-end by securing the male protrusion 16 of one segment 10 into the female receptacle 18 of an adjacent segment 10, as shown. Although only one of each of male protrusions 16 and female receptacles 18 are disposed on each

segment 10, as shown, other joining configurations could be employed, such as the one shown in Figs. 1-13, particularly if there is a desire to join the segments 10 in an offset manner, as shown in Fig. 9.

[0029] Important objectives that are met by these examples are as follows:

1. 1) The modular warning strip segment 10 is sufficiently heavy to stay in place with minimal movement when run over by a vehicle, but not too heavy for one person to lift, position, or handle.
2. 2) An assembly of segments 10, when joined together as shown in Figs. 8, 9, or 20, must be rigid enough, particularly at the linkable joints, so that they do not separate from one another when a vehicle runs over them.
3. 3) The segments 10, both individually and when assembled, must be flexible enough to conform to varied and uneven roadway surfaces. The flexibility needs to be intimately connected to an idyllic weight and closely linked to close proximity flexibility both axially and transversely, preferably.
4. 4) The segment 10 is about 30.48 - 35.56 cm (12-14 inches) in width, with very gentle approaching and departing ramped portions 24, each about 3.81 - 6.35 cm (1 ½ - 2 ½ inches) in width, having lead in and exit angles of a maximum of 15 degrees, and preferably 10 degrees. Importantly, with respect to the embodiment of Figs. 14-20, the metal plate 38 does not extend into the ramped portions 24 of the segment 10, thereby improving flexibility for positioning of the segments, and for driving over the segments and ensuring that the segments conform to the roadway surface.
5. 5) Each segment has a maximum height of about 1.91 cm (¾ inches) with a length of about 1.22 m (4 feet).
6. 6) With respect particularly to the embodiment of Figs. 14-20, the small laser slits or living hinges 42 are a big advantage over using separate spaced plates, because positioning a single plate in the mold, rather than a plurality of separate plates, improves efficiency and precision in manufacture.

[0030] An exemplary embodiment of the invention is illustrated in Figs. 21-23. In this embodiment, a rumble or warning strip assembly 28 comprises two opposed linear segments 58 which are sandwiched about a jigsaw segment 60 comprising two joined jigsaw members 62. In certain embodiments, the segments 58 and members 62 are fabricated of steel, such as pressure-cast steel, or other suitable metal, and include tapered ramps 64, 66 on each of the leading and trailing edges, respectively. A urethane sheet, or other suitable material, may be bonded to the bottom face of each segment 58 and member 62. Non-slip, anti-corrosion coatings are applied to the top and sides thereof, as indicated. In exemplary embodiments, each of the segments 58 and members 62 are powder-coated with a flat, textured finish. Urethane strips may be adhered to the bottom surfaces of the segments 58 and members 62 lengthwise. Alternatively, the segments/members may be dipped in urethane, or injection molded with a urethane surface.

[0031] Each of the jigsaw members 62, which together comprise the jigsaw segment 60, has a straight edge 68 and a jigsaw edge 70. The jigsaw edge comprises a series of protrusions 72 and concavities 74 which are particularly designed to ensure a tight and immovable connection with corresponding protrusions and concavities on an adjacent jigsaw member edge. Of particular advantage is that the jigsaw end or edge 70 is designed to be universal. In other words, it is not either left or right-handed. So, as shown in Fig. 21, the two joined jigsaw members 62 are identical in configuration, but simply reversed in orientation.

[0032] Though the assembly 28 is illustrated as comprising two joined jigsaw members 62 (with one in reverse orientation compared to the other one), forming a jigsaw segment 60, and segments 58 joined to either edge of the jigsaw segment 60, the inventive system is completely flexible in allowing for any combination of assembly of the various segments and members illustrated in Figs. 21-23. For example, additional segments 58 may be attached to each end of the assembly 28, or additional jigsaw segments 60 could be secured to one or both edges of the assembly 28. In some instances, it may be desirable to simply secure a plurality of segments 58 together, while in other instances it may be desirable to secure a plurality of jigsaw segments 60 together. Any such combinations are possible, depending upon design parameters and application. Individual segments and members 58, 62, respectively, may be moved into place via a boom and magnet system or other suitable approach. Manual assembly is an option.

[0033] As shown in Fig. 21, the various joined segments 58, 60 are secured together using a cord 76, which may comprise a cable, wire rope, or the like, may be formed of steel, such as braided steel, or other suitable material, and extends through openings 78, which may comprise holes or slots formed in each segment 58 and member 62. If open slots 78 are utilized, rather than holes, it may be advantageous to weld the cords in position within the slots to hold them in place.

[0034] Figs. 24 and 25 illustrate a modified embodiment of the segments 58 shown in Figs. 21-23, though the features shown in Figs. 24-25 for segments 58 may also be employed in the jigsaw members 62 of Figs. 21-23. In particular, through holes 80 are disposed in each segment 58, member 62. As illustrated, one such hole 80 is disposed in a center region of the segment, while in each of the leading and trailing edges 64, 66 another such hole 80 may be disposed as well. As shown, there is a wider bell mouth portion 82 of each of the holes 80 near a top surface of the segment.

[0035] A purpose for the through holes 80 is to serve as a locking system in the event that the urethane coating discussed above is cast in place about the segments 58 and members 62 during fabrication. Using such a method, where the urethane is cast in place, the urethane may flow through the holes 80, locking the urethane to the bar or segment.

[0036] Figs. 26-29 illustrate an example of a warning strip segment assembly 28, assembled in accordance with the principles discussed above, wherein a plurality of segments 58 are secured together with a length of cord 76, comprising a stainless steel cable. In a typical

assembly, having a length sufficient to extend across a roadway lane, as shown in Fig. 27, approximately thirty or so segments, having a total weight of approximately 81.6 kg (180 lb.) or so, may be joined together as shown. Notably, as the segments are assembled together by extending a loop of cord 76 through each of the two openings 78 in each segment, thereby stringing the segments 58 together, as shown, spacers 84 are disposed on the cord 76 between each segment 58. Each spacer comprises a tube having a sufficient diameter to fit over the cord 76, and functions to ensure that a space is maintained between each segment 58, as is evident from a review of Figs. 26-29. Such spacer tubes 84 preferably comprise a corrosion-resistant material, which has enough wall thickness to ensure adequate strength that the segment assembly 28 may be rolled up without kinking the cords 76. The spacers 84 may be comprised, for example, of copper or stainless steel.

[0037] Now, again with reference to Figs. 26-29, a technique for assembling a warning strip assembly 28 may involve assembling a subassembly 86 (Fig. 28), which is only a portion of the size of the assembly 28, and then joining a plurality of the subassemblies 86 together to create a full assembly 28. Specifically, as noted above, a full warning strip assembly 28 can comprise thirty or more segments 58, and thereby weigh 81.6 - 95.3 kg (180-210 pounds). In some circumstances, a user may not wish to move a 81.6 kg (180 lb.) assembly 28 from a truck to a roadway deployment, and would prefer to move a plurality of lighter subassemblies 86 to the deployment location, securing the subassemblies 86 to one another to assemble the full assembly on the roadway location. A subassembly of any desired size, such as, for example, 15 segments 58, is assembled over a suitable length of cord 76, with spacers 84 between each segment 58. This essentially creates a half-strip 86 having a length of 1.52 or 7.83 m (5 or 6 feet) and a weight of about 47.2 kg (104 lb), suitable for extending across about one-half of a lane of traffic. This half-strip 86 can be deployed across the roadway lane. In this arrangement, the last segment on the half-strip comprises a jigsaw segment 62, wherein the jigsaw edge 70 is exposed at the end of the half-strip. The ends of the cord 76 are welded into the openings 78 in this end jigsaw segment 62. Set screws may be disposed in the top and bottom of the segment. Then, another half-strip may be joined end-to-end, on the roadway site, to the first half-strip by securing an end jigsaw segment 62 to the first end jigsaw segment 62 by joining their respective jigsaw edges together, thereby creating a full jigsaw member which joins the two subassemblies 86 together to create a full warning strip assembly 28 covering the entire roadway lane.

[0038] Thus, to summarize, subassemblies 86 are joinable together to form a complete assembly 28 on the roadway. Cords 76 form loops 88 at one end of each subassembly 86, so that a completed assembly 28 has a cord loop 88 at each end thereof, as shown, for assisting in deploying the subassemblies/assemblies.

[0039] In an exemplary embodiment, each strip subassembly 86 is 1.68 m (5 ½ feet) in length, has a jigsaw member 62 on one end, and has a cord handle 88 on the other end. Two subassemblies 86 connect together by joining respective jigsaw members 62, as shown, to make a 3.35 m (11 foot) long assembly 28 that spans a lane of roadway.

[0040] In this exemplary embodiment, the jigsaw members 62 are identical, regardless of how they are oriented. As noted above, there are no designated "left" or "right" handed parts. The jigsaw connection is at the middle of the assembly 28, thus keeping the connection as far away from the passing vehicle tires as possible. In this particular assembly, again as previously described, the weight of each subassembly 86 is 47.2 kg (104 lb), thereby creating an assembly 28 of about 94.3 kg (208 lb.), though these weights may vary depending upon materials and scale of size. In this example, the cord 76 connecting the assembly is corrosion resistant/ marine grade 3/8" wire rope.

[0041] The bottom surface of each segment 58 and jigsaw member 62 is 1/8" thick urethane, in one particular example, bonded to the steel strips with a special two-part adhesive. The spacers 84 are made from heavy wall stainless steel.

[0042] In Fig. 30 there is illustrated still another exemplary embodiment of the present invention, which is similar to that shown in Figs. 21-23 and 26-29, illustrating a warning strip subassembly 86, wherein all like elements to those in the embodiment of Figs. 21-23 and 26-29 are designated by like reference numerals. The only substantial difference between this and the previous embodiment is that the subassembly 86 in this embodiment is fabricated of segments 58 and jigsaw member 62, wherein alternating, adjacent segments and the jigsaw member 62 are differently colored, alternating between darker and lighter colors, as shown. In the illustrated embodiment, the lighter colored segments 58 and jigsaw members 62 are comprised of a colored aluminum, whereas the darker colored segment 58 and jigsaw member 62 are comprised of a colored steel. Significantly, in addition to the contrasting colors of adjacent segments 58 and jigsaw member 62, the lighter-weight aluminum segments result in a much lighter subassembly 86 than in the previous embodiments. For example, in one exemplary embodiment, the subassembly 86 is approximately 36.3 kg (80 lb), rather than 47.2 kg (104 lb), resulting in a total weight of 72.6 or so kg (160 or so lb) for the assembly 28, instead of 92.5 or so kg (204 or so lb). This lighter weight, of course, makes the strip assembly easier to handle. Advantageously, the contrasting alternating colors of the segments 58 and jigsaw members 62 also greatly improve visibility of the assembly 28 to approaching motorists. On dark asphalt, the lighter segments 58 and jigsaw members 62 are particularly visible, while on light concrete, the darker segments 58 and jigsaw members 62 are particularly visible.

[0043] Accordingly, although an exemplary embodiment of the invention has been shown and described, it is to be understood that all the terms used herein are descriptive rather than limiting, and that many changes, modifications, and substitutions may be made by one having ordinary skill in the art without departing from the scope of the invention defined by the claims.

REFERENCES CITED IN THE DESCRIPTION

Cited references

This list of references cited by the applicant is for the reader's convenience only. It does not form part of the European patent document. Even though great care has been taken in compiling the references, errors or omissions cannot be excluded and the EPO disclaims all liability in this regard.

Patent documents cited in the description

- US7736087B [0001]
- US5769563A [0001]

PATENTKRAV

1. Modulopbygget motorvejsadvarselsstribesystem, der omfatter en flerhed af segmenter (58) samlet med hinanden for at dannet en advarselsstribeenhed (28) med en længde, hvor hvert af flerheden af segmenter er adskilt fra tilstødende segmenter langs advarselsstribens længde, hvor
5 segmenterne samles langs en snor (76) placeret langs advarselsstribeenhedens længde;
kendetegnet ved, at advarselsstribeenheden omfatter en første advarselsstribeunderenhed (86) og en anden advarselsstribeunderenhed (86), der samles med hinanden ved indgreb af et første udskåret element (62) på en ende af den første advarselsstribeunderenhed og et andet udskåret element (62) på en ende af den anden advarselsstribeunderenhed.
10
2. Modulopbygget motorvejsadvarselsstribesystem ifølge krav 1, og som endvidere omfatter en flerhed af afstandsstykker (84) placeret på snoren langs advarselsstribeenhedens længde, hvor hvert af flerheden af afstandsstykker placeres mellem tilstødende segmenter (58) for at bevare en afstand mellem hvert tilstødende segment.
15
3. Modulopbygget motorvejsadvarselsstribesystem ifølge krav 2, hvor hvert af afstandsstykkerne omfatter en hul struktur, der er dimensioneret til placering omkring snoren.
4. Modulopbygget motorvejsadvarselsstribesystem ifølge krav 2 eller krav 3, hvor hvert af
20 afstandsstykkerne omfatter et rør dannet af et korrosionsbestandigt materiale.
5. Modulopbygget motorvejsadvarselsstribesystem ifølge et hvilket som helst af de foregående krav, hvor hvert af flerheden af segmenter omfatter en åbning (78) placeret derigennem til modtagelse af snoren.
25
6. Modulopbygget motorvejsadvarselsstribesystem ifølge krav 5, og som endvidere omfatter en anden åbning (78) placeret gennem hvert af flerheden af segmenter til modtagelse af snoren.
7. Modulopbygget motorvejsadvarselsstribesystem ifølge krav 6, hvor snoren går ud gennem
30 én af åbningerne i et yderste segment på en første ende af advarselsstribeenheden, strækker sig i en bue mod den anden åbning på det yderste segment og går ind gennem den anden åbning, hvorved der dannes en grebssløjfe på den første ende af advarselsstribeenheden.
8. Modulopbygget motorvejsadvarselsstribesystem ifølge krav 6 eller krav 7, hvor snoren
35 strækker sig gennem den anden åbning i hvert af de samlede segmenter, går ud gennem den anden

åbning i et yderste segment på en anden ende af advarselsstribeenheden, strækker sig i en bue mod den anden åbning på et yderste segment i den anden ende, og går ind gennem den anden åbning, hvorved der dannes en anden grebssløjfe (88) på den anden ende af advarselsstribeenheden.

5 9. Modulopbygget motorvejsadvarselsstribesystem ifølge et hvilket som helst af de foregående krav, hvor hvert af de første og anden udskårne elementer (62) omfatter en lige kant (68) og en modstående udskåret kant (70), hvor den udskårne kant af hvert af de første og anden udskårne elementer omfatter en række fremspring (72) og konkaviteter (74), der er tilpasset til at gå i indgreb med den udskårne kant af det andet udskårne element, således at der, når de første og
10 anden udskårne elementer samles med hinanden ved indgreb af deres respektive udskårne kanter, dannes et udskåret segment (60).

10. Modulopbygget motorvejsadvarselsstribesystem ifølge et hvilket som helst af de foregående krav, hvor de første og anden udskårne elementer i det væsentlige har en identisk
15 konstruktion.

11. Modulopbygget motorvejsadvarselsstribesystem ifølge et hvilket som helst af de foregående krav, hvor nogle af eller samtlige flader af hvert segment er dækket af et beskyttelsesmateriale.
20

12. Modulopbygget motorvejsadvarselsstribesystem ifølge et hvilket som helst af de foregående krav, hvor ét eller flere af flerheden af segmenter har en mørkere farve og ét eller flere af flerheden af segmenter har en lysere farve.

25 13. Modulopbygget motorvejsadvarselsstribesystem ifølge krav 12, hvor segmenterne med den lysere farve og segmenterne med den mørkere farve samles på vekslende måde.

14. Modulopbygget motorvejsadvarselsstribesystem ifølge et hvilket som helst af de foregående krav, hvor vekslende segmenter fra flerheden af segmenter er dannet af forskellige
30 materialer.

15. Modulopbygget motorvejsadvarselsstribesystem ifølge et hvilket som helst af de foregående krav, hvor nogle af segmenterne er dannet af stål og andre af segmenterne er dannet af aluminium.
35

DRAWINGS

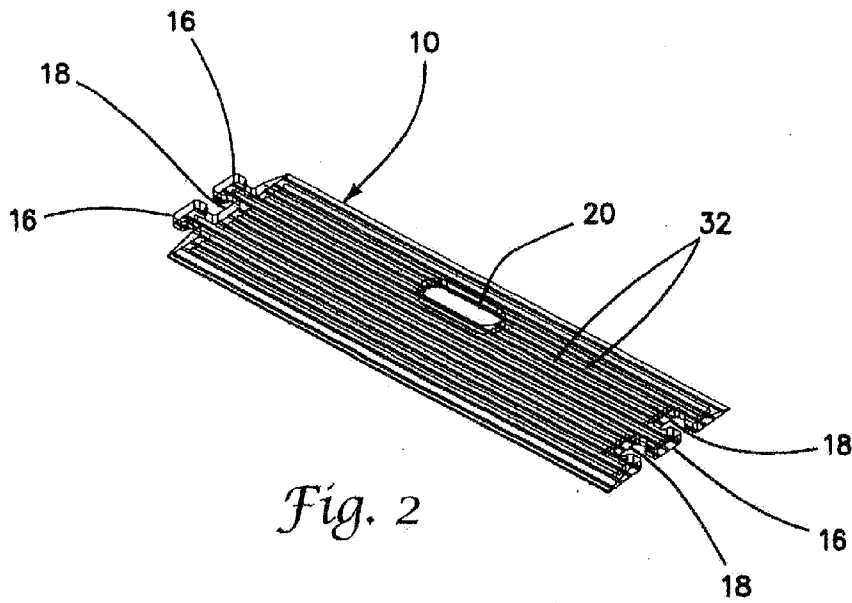
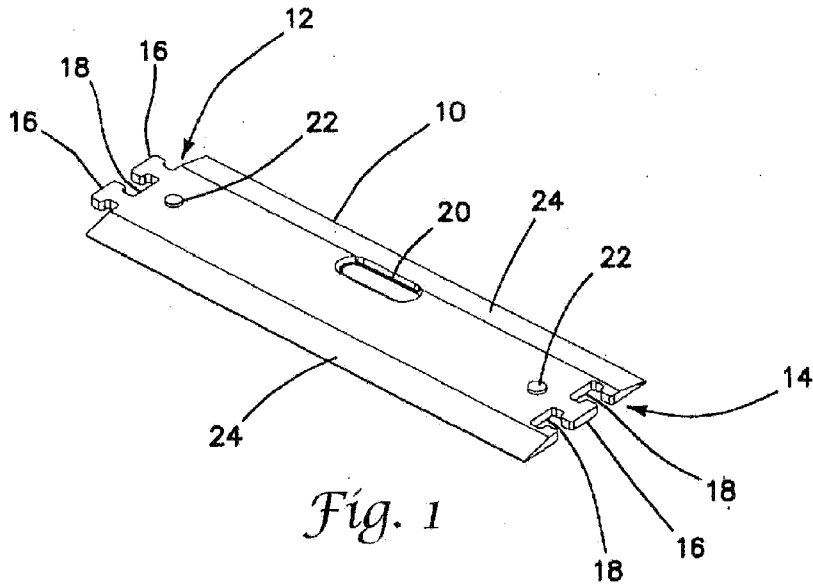

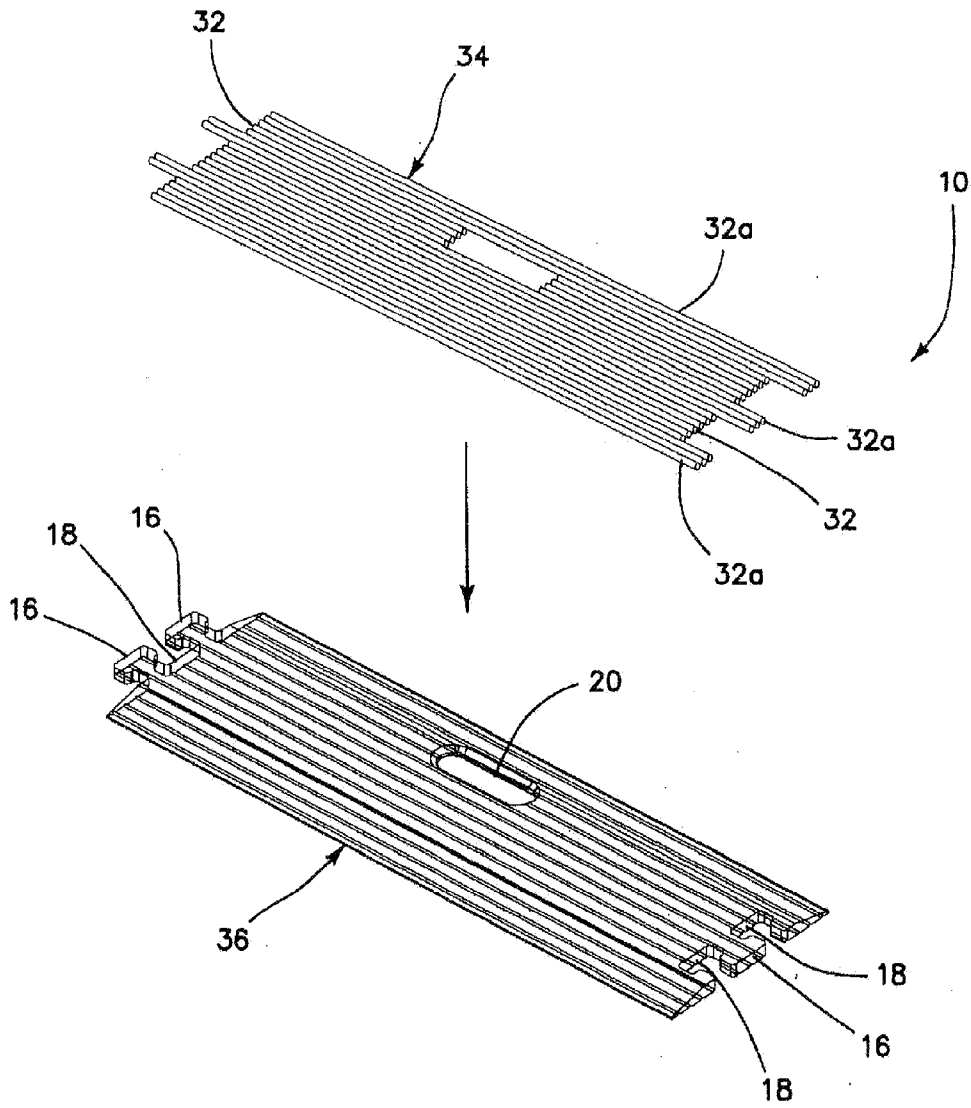

Fig. 3

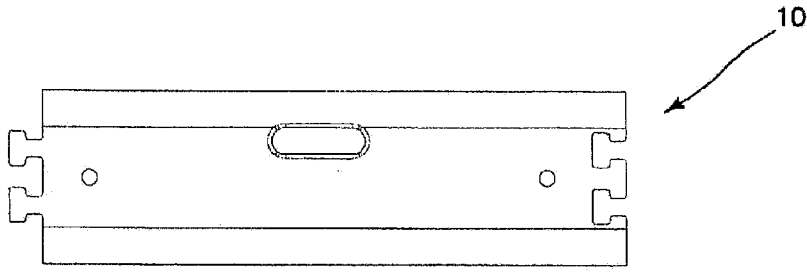

Fig. 4

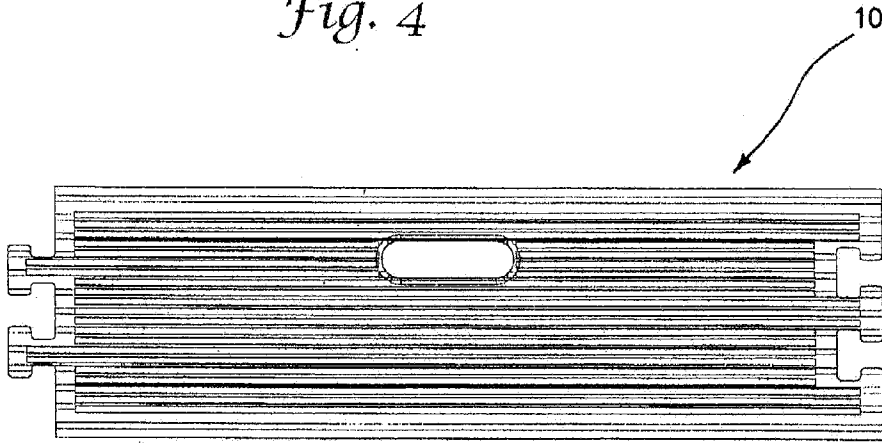

Fig. 5

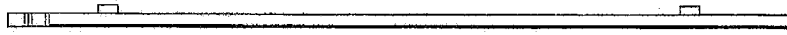

Fig. 6



Fig. 7

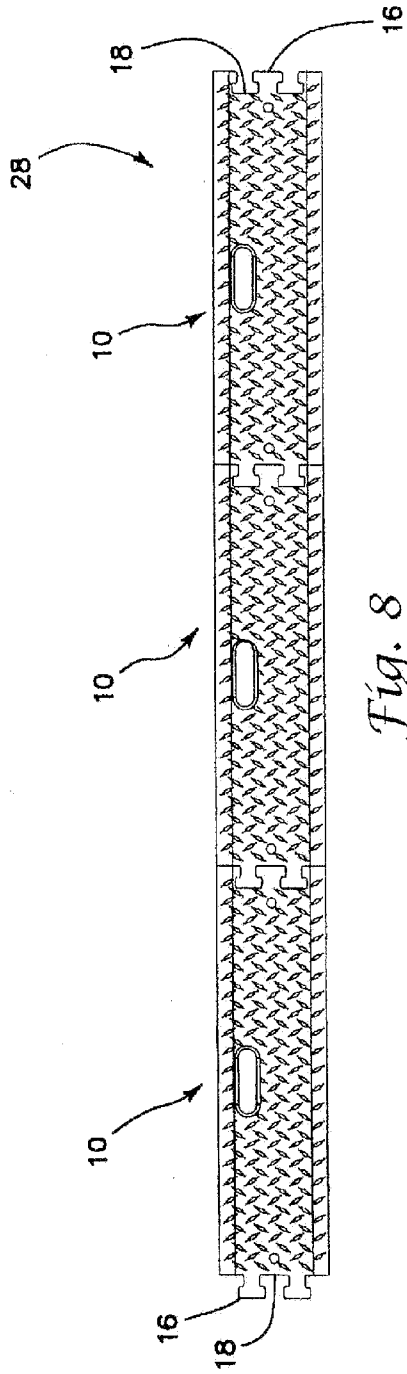

Fig. 8

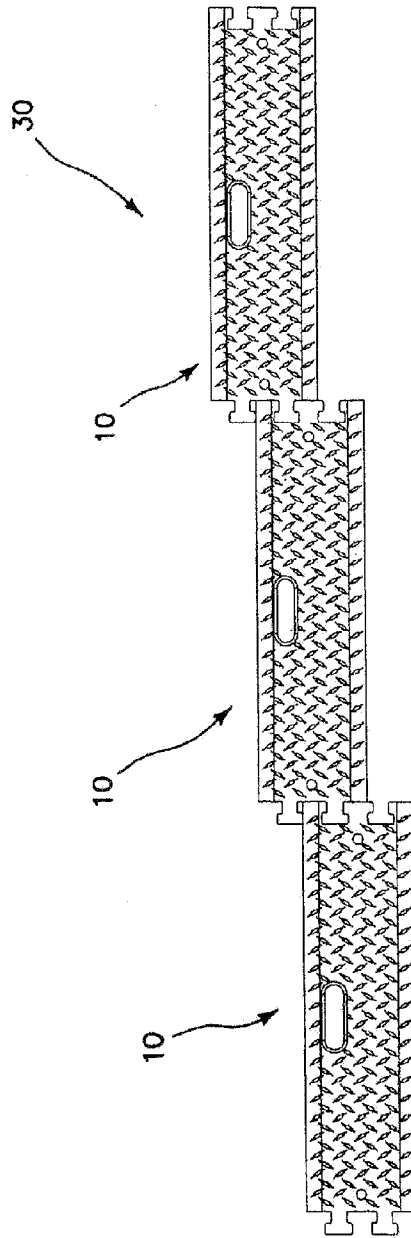

Fig. 9

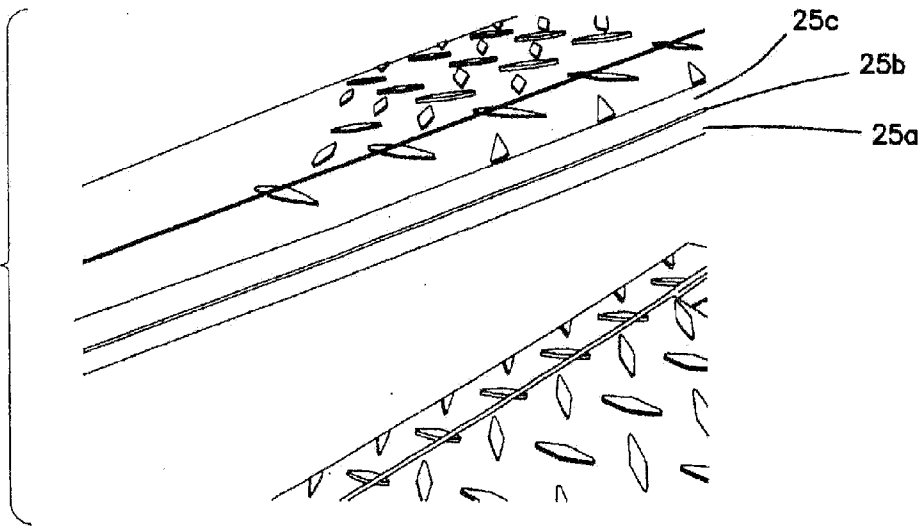
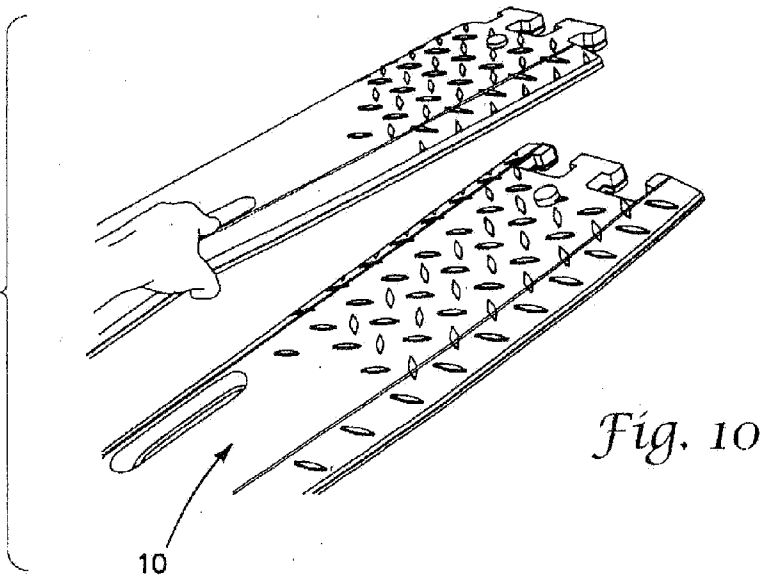

Fig. 11

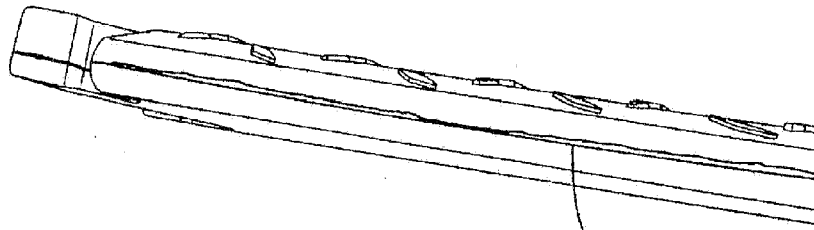

Fig. 12

26

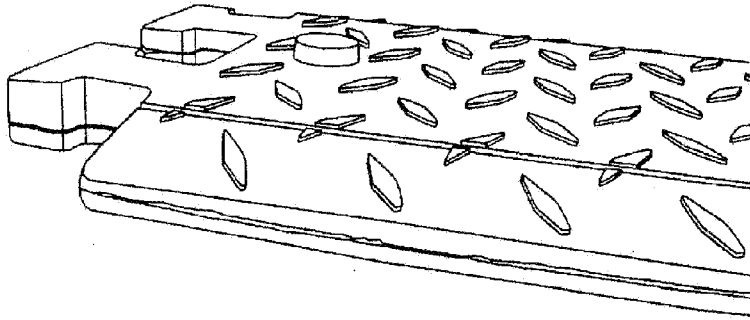

Fig. 13

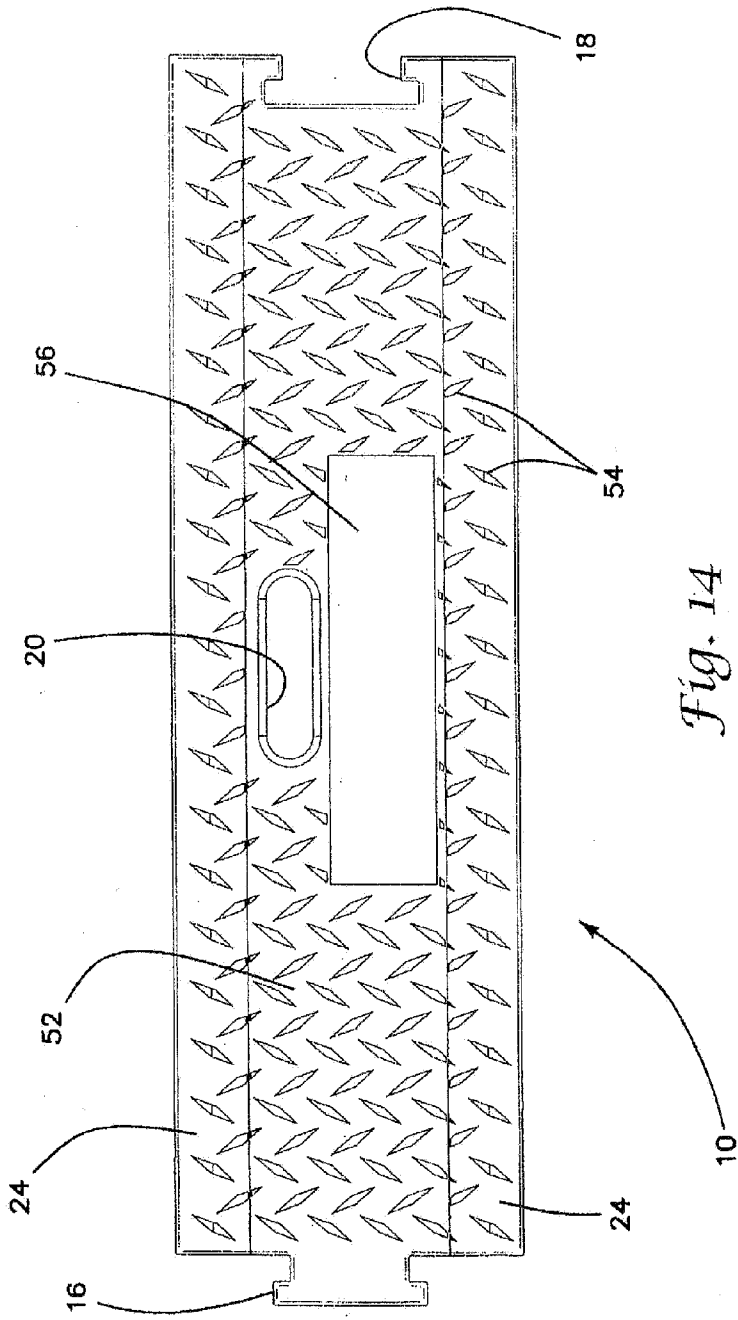
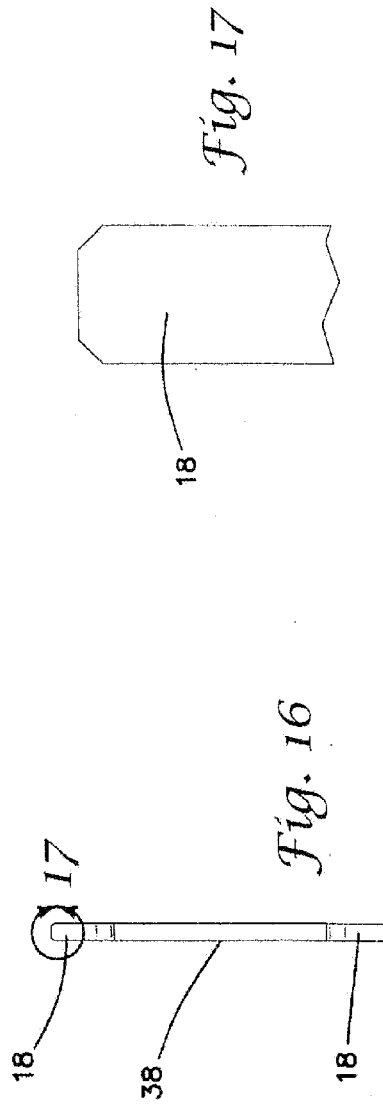
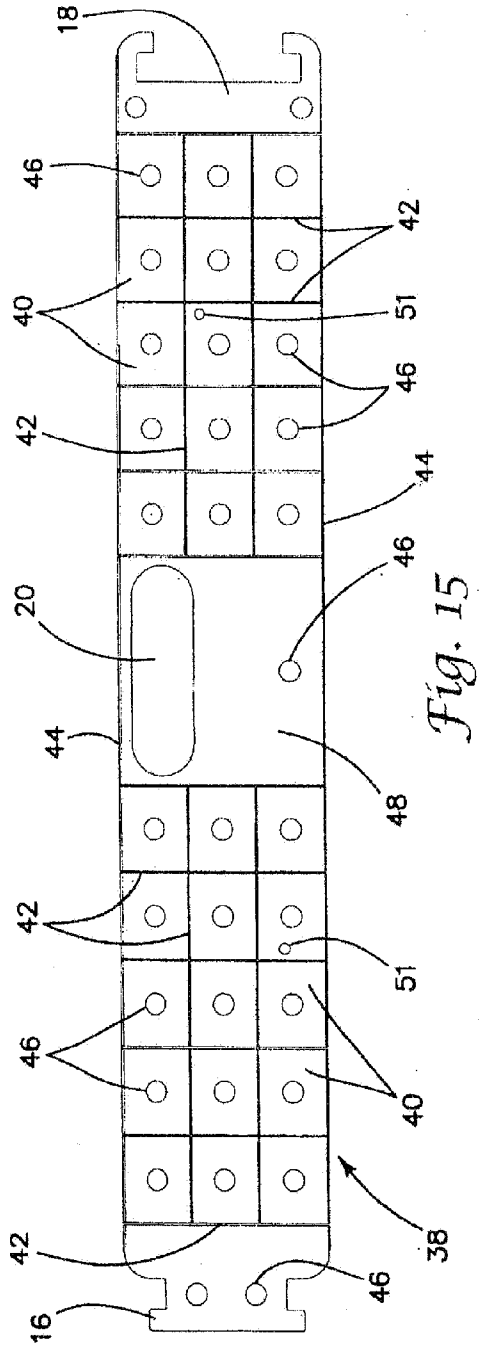

Fig. 14



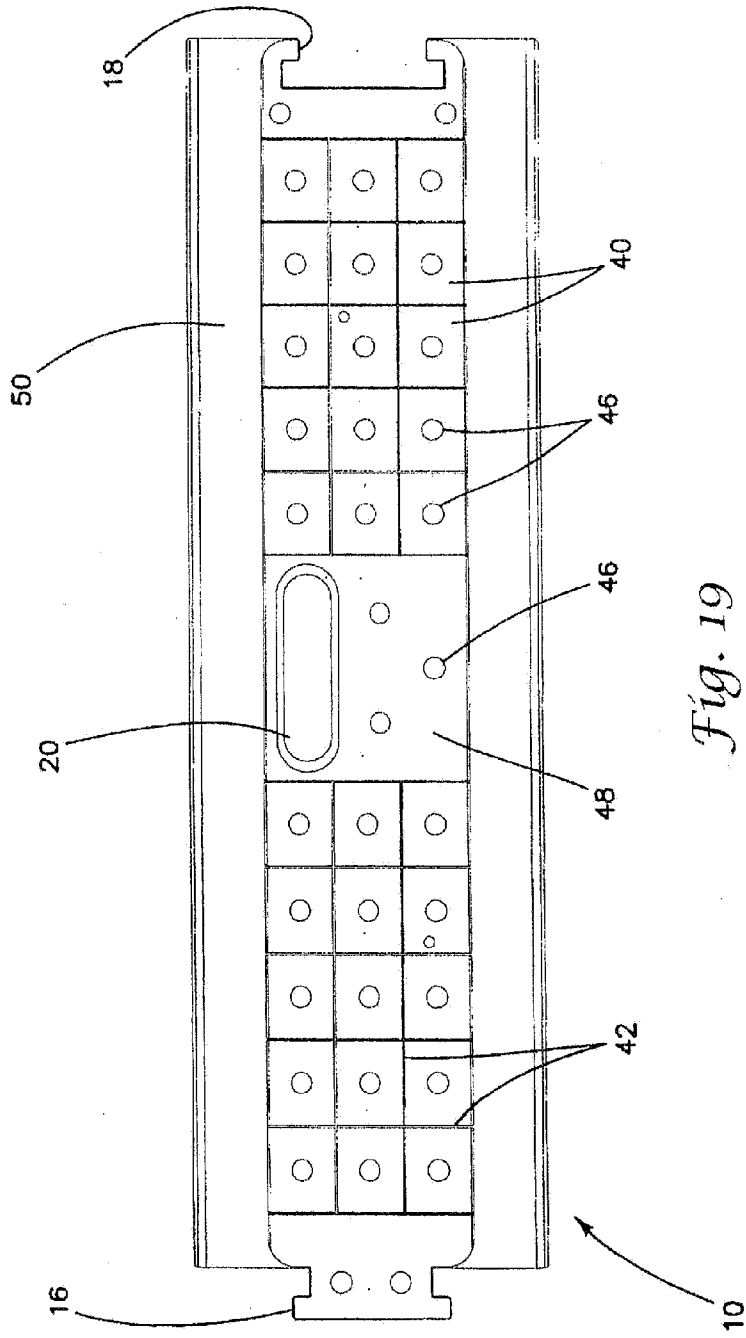

Fig. 19

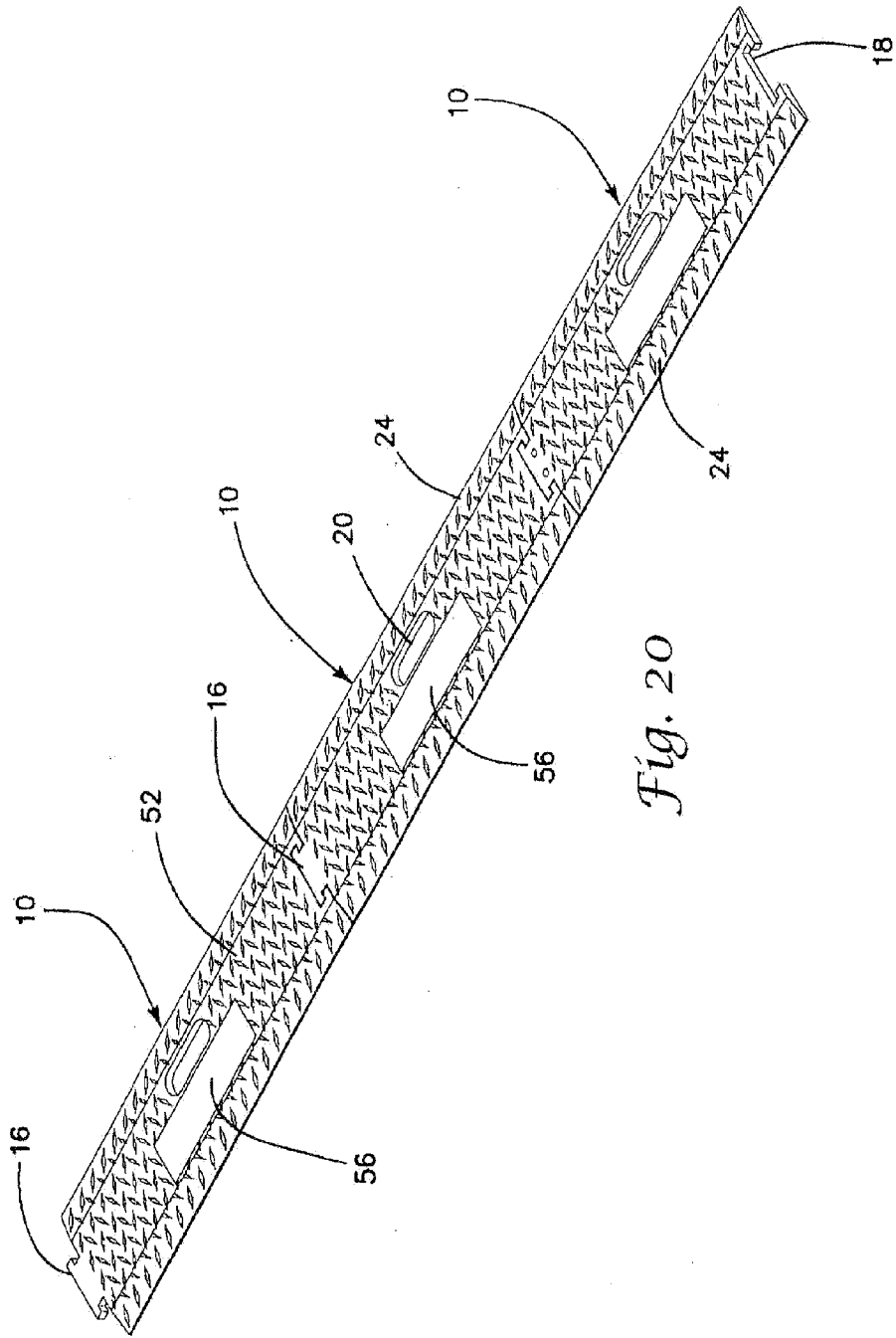
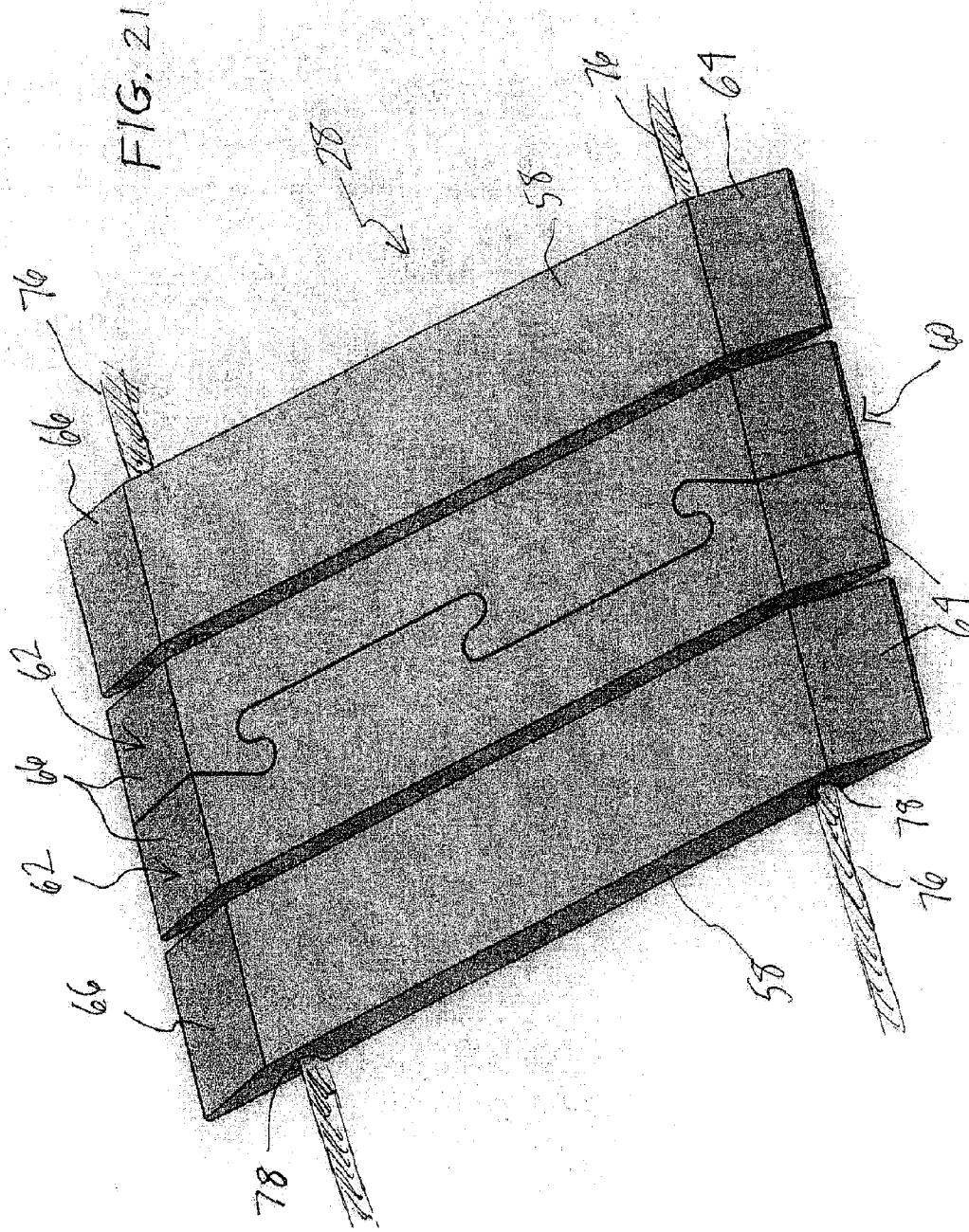

Fig. 20



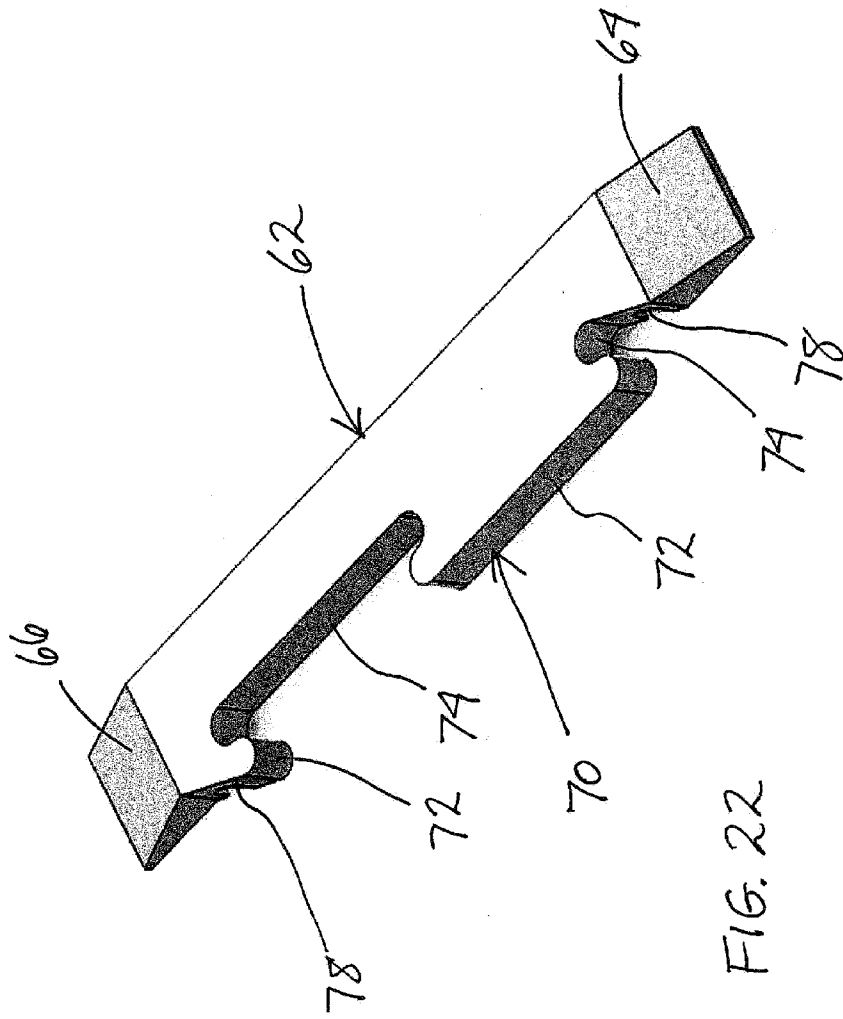
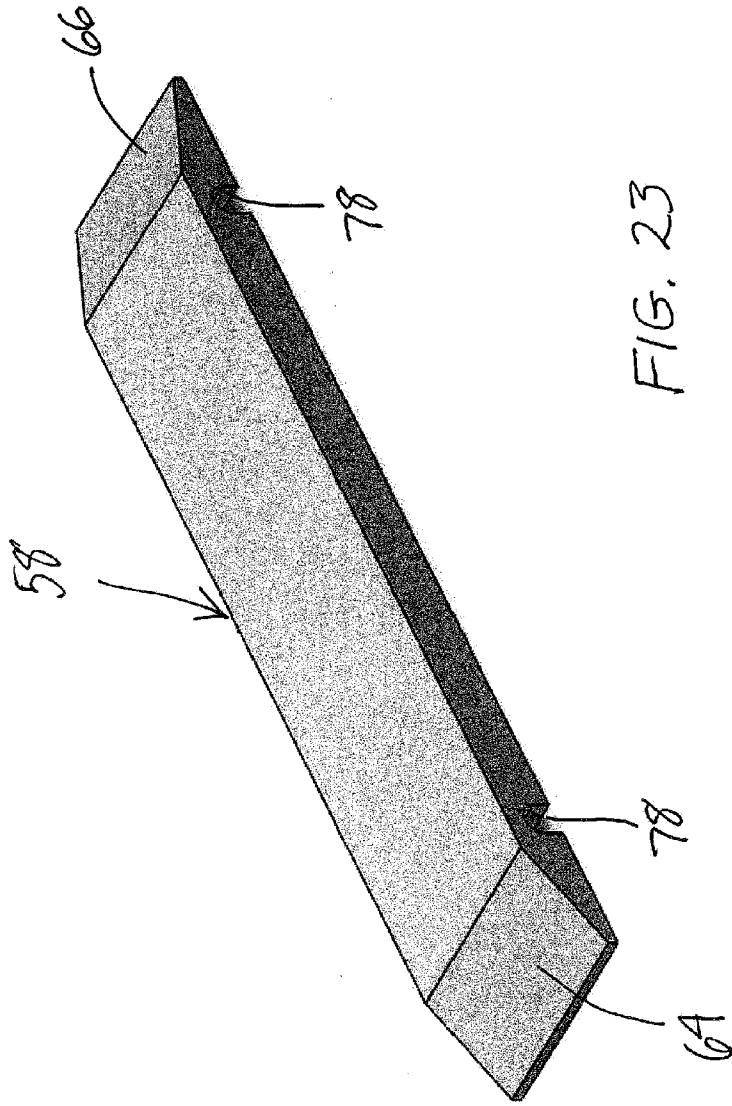

FIG. 22



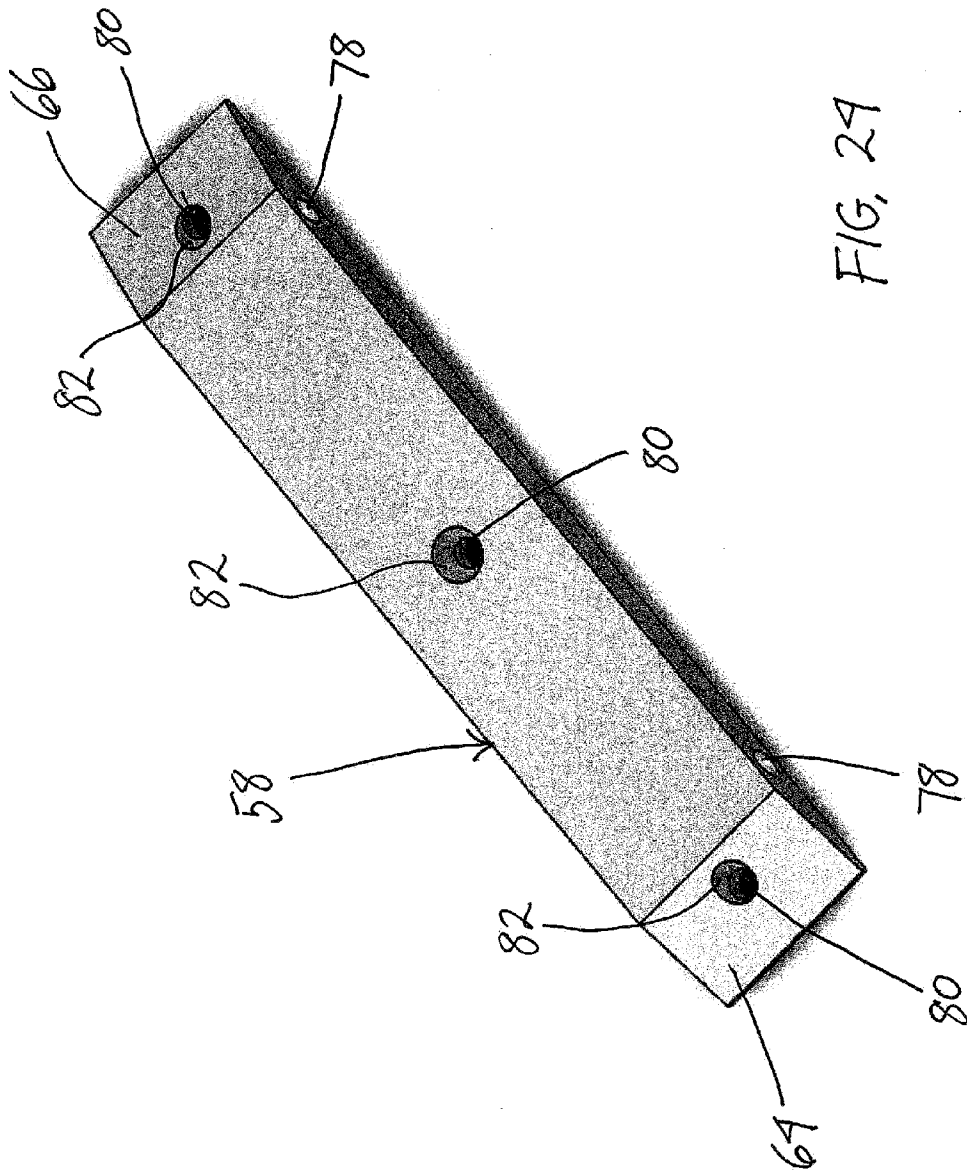

FIG. 29

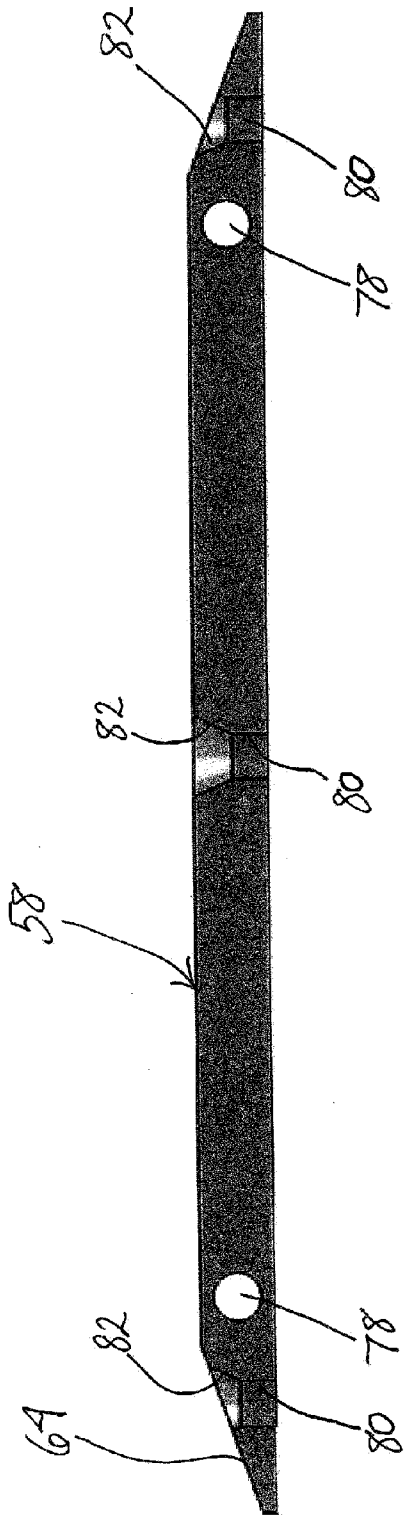

FIG. 25

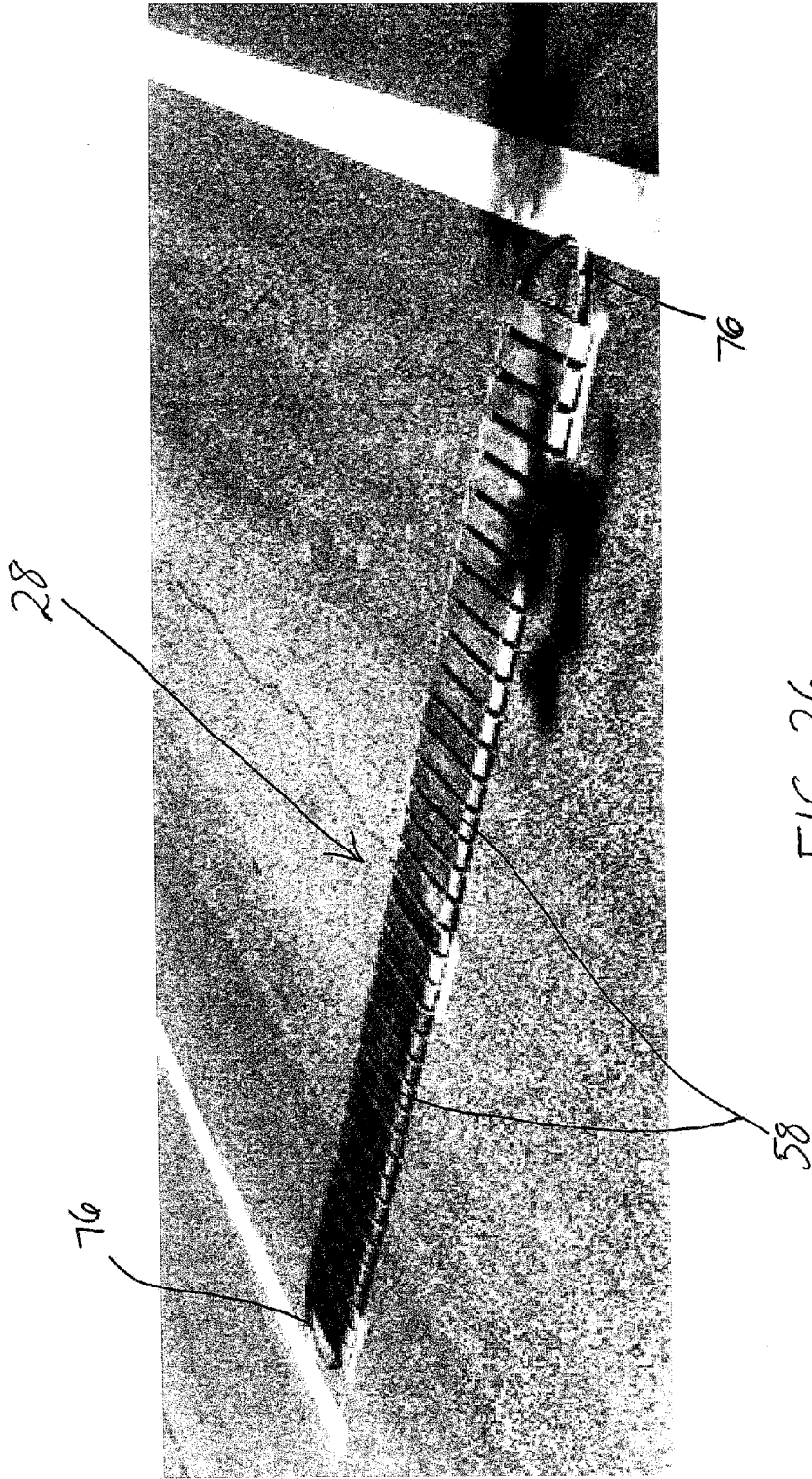

FIG. 26

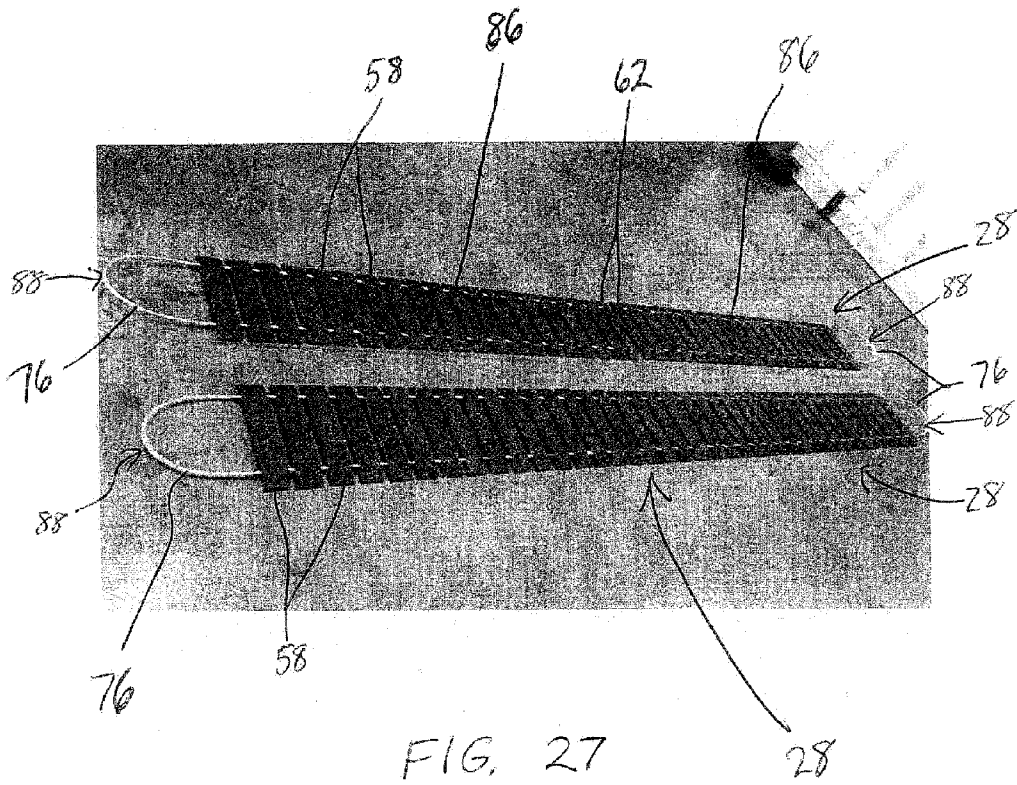

FIG. 27

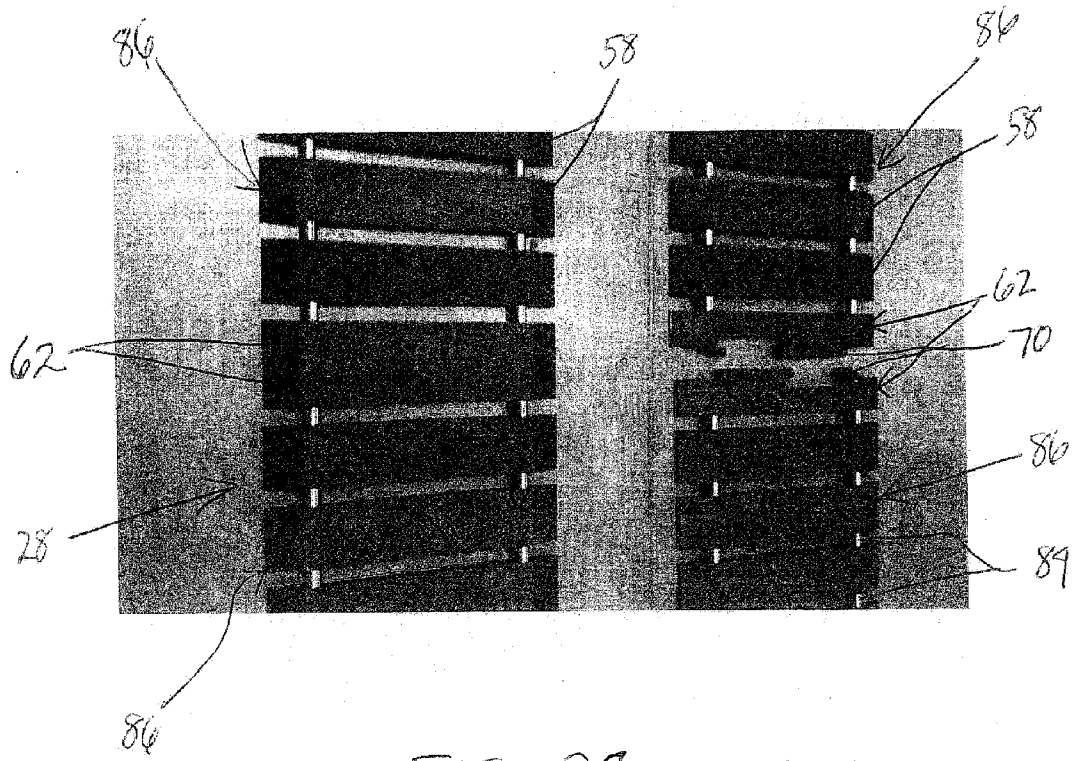

FIG. 28

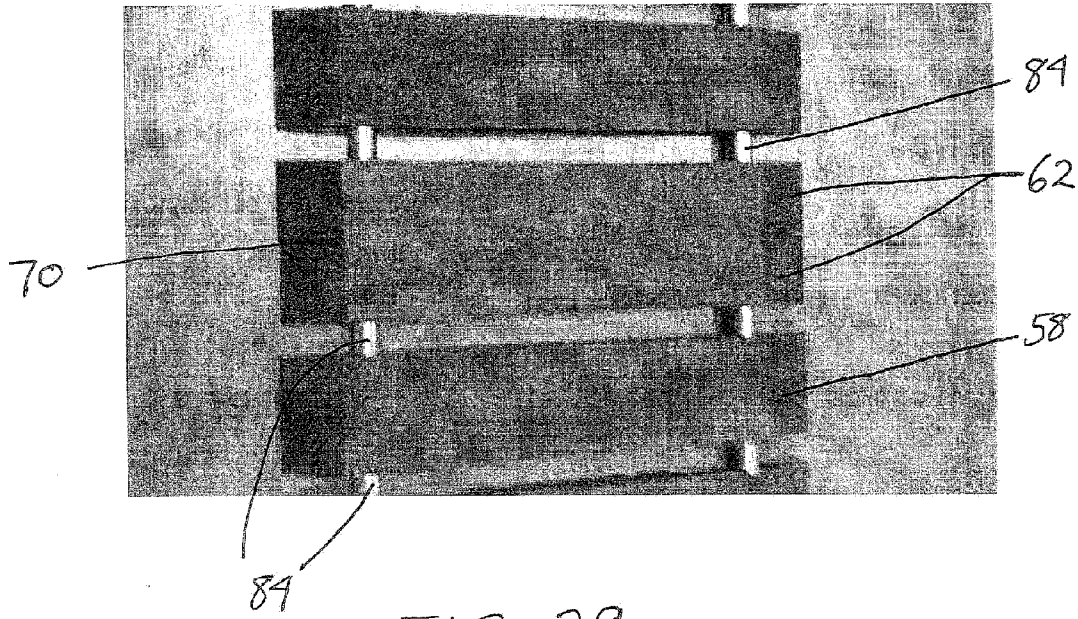

FIG. 29

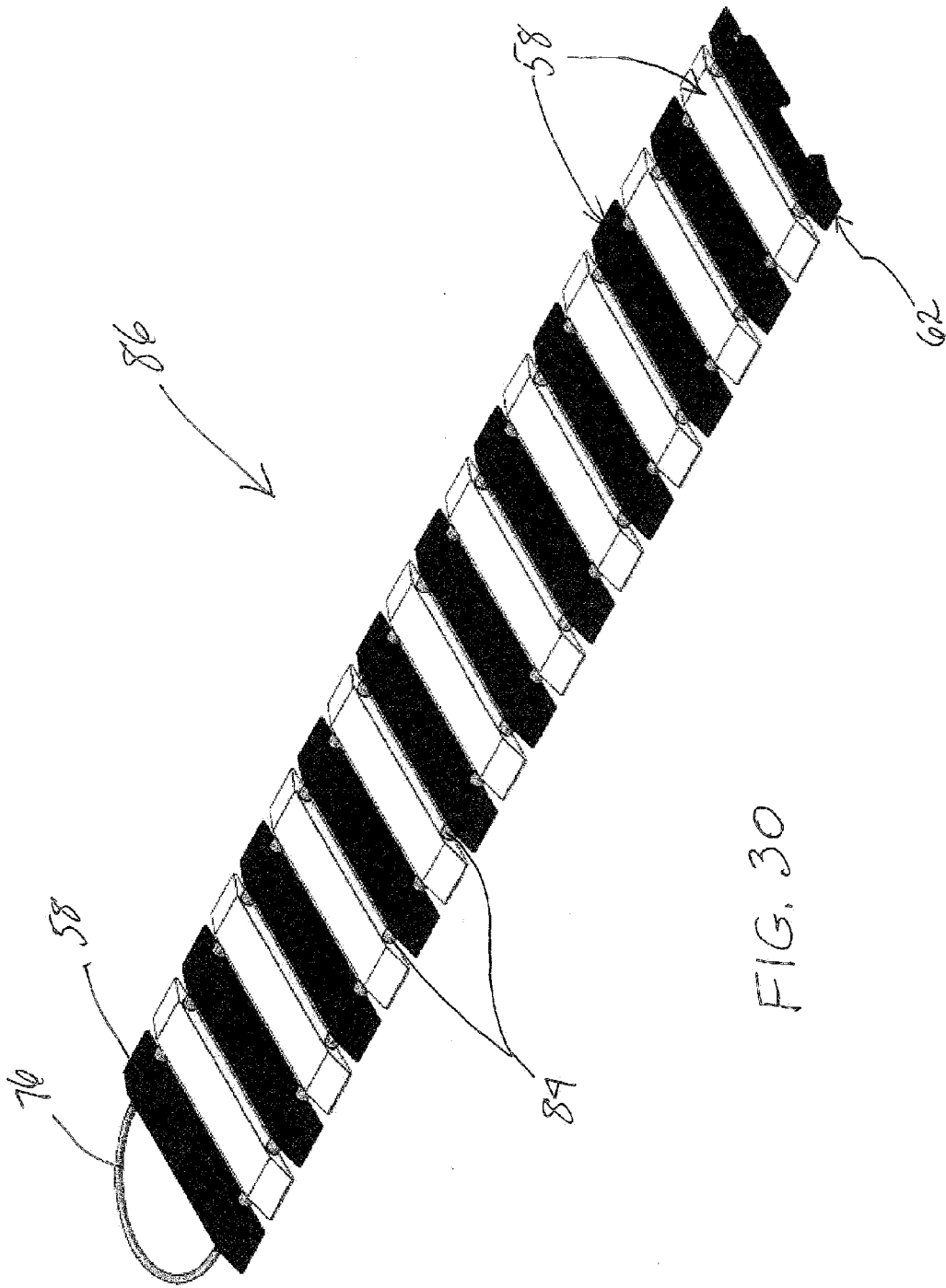

FIG. 30