

(No Model.)

2 Sheets—Sheet 1.

A. R. THOMPSON.  
RAILWAY CAR HEATER.

No. 385,534.

Patented July 3, 1888.

Fig. 1.

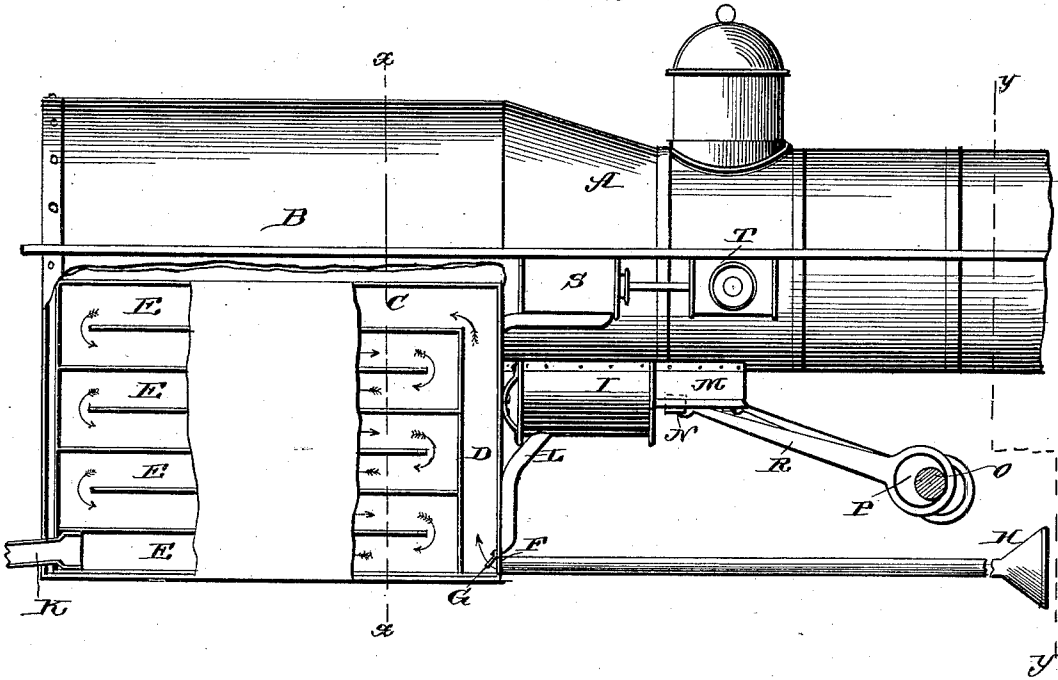

Fig. 2.

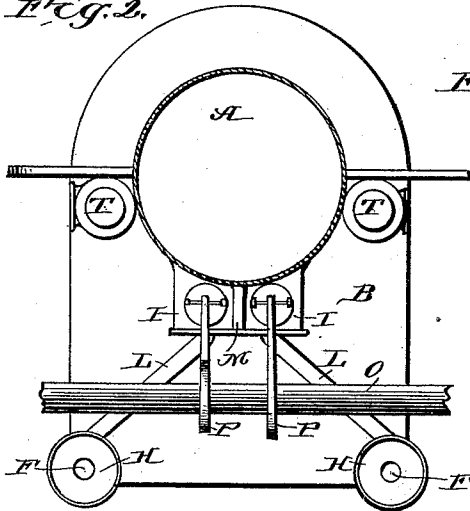

Fig. 3.

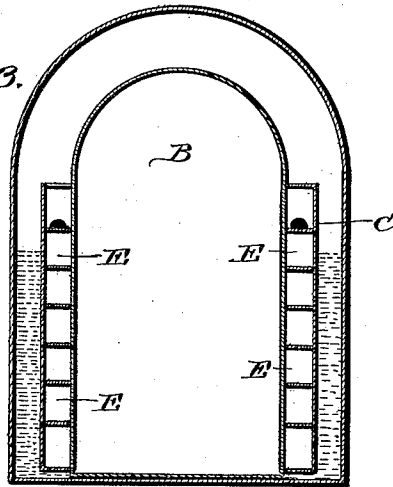

Fig. 5.



Witnesses, Y

J. A. Ryan  
J. E. Garner

Inventor,

Albert R. Thompson.

By his Attorneys

C. Snow & Co.

(No Model.)

2 Sheets—Sheet 2.

A. R. THOMPSON.  
RAILWAY CAR HEATER.

No. 385,534.

Patented July 3, 1888.

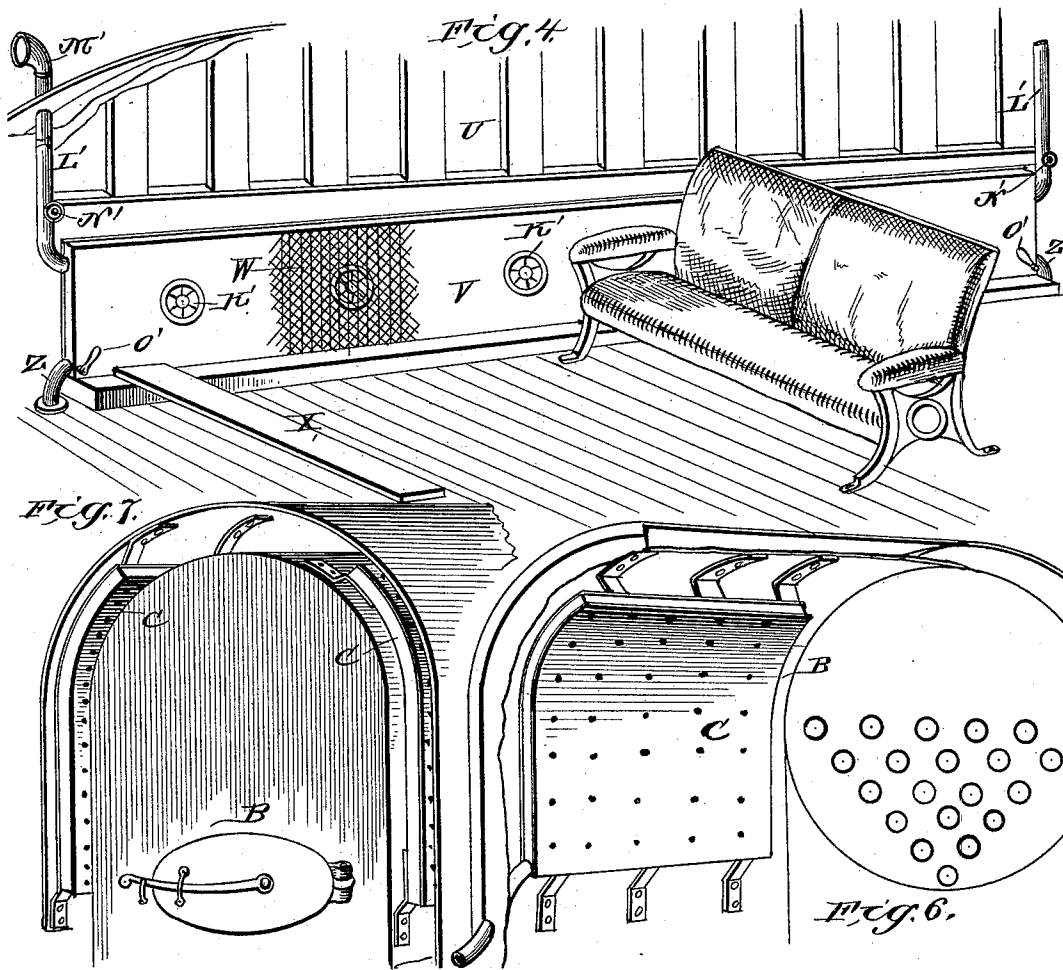

Witnesses,  
*Joe. A. Ryan*  
*J. W. Garner*

Inventor  
*Albert R. Thompson.*  
By his Attorneys  
*C. A. Howden*

# UNITED STATES PATENT OFFICE.

ALBERT RHODES THOMPSON, OF STONE CHURCH, PENNSYLVANIA.

## RAILWAY-CAR HEATER.

SPECIFICATION forming part of Letters Patent No. 385,534, dated July 3, 1888.

Application filed July 7, 1887. Serial No. 243,682. (No model.)

*To all whom it may concern:*

Be it known that I, ALBERT RHODES THOMPSON, a citizen of the United States, residing at Stone Church, in the county of Northampton and State of Pennsylvania, have invented a new and useful Improvement in Railway-Car Heaters, of which the following is a specification.

My invention relates to an improvement in railway-car heaters; and it consists in the peculiar construction and combination of devices that will be more fully set forth hereinafter, and particularly pointed out in the claims.

In the accompanying drawings, Figure 1 is an elevation, partly in section, of a portion of a locomotive provided with my improved air-heating device. Fig. 2 is a vertical sectional view of the same, taken on the line *yy* of Fig. 1. Fig. 3 is a similar view taken on the line *xx* of Fig. 1. Fig. 4 is a perspective view of a portion of the interior of a railway-car provided with my improved heat-radiating appliances. Fig. 5 is a detached perspective view of one of the heat-conducting pipes. Figs. 6 and 7 are modified forms of my invention.

A represents the boiler of the locomotive of the usual construction, and B represents the fire-box of the same. In the spaces formed between the opposing side walls of the fire-box and the boiler-shell are heating-chambers C, each of which is provided at its front end with a vertical channel, D, which extends from the lower side of the same to the upper side thereof, and there communicates with a series of horizontal tortuous channels, E, which communicate with each other at opposite ends, as shown at Fig. 1.

In the lower front corner of each heating-chamber is an inlet-opening, F, which is covered on its inside by an inward-opening valve, G.

H represents an induction-funnel which communicates with the opening F, and is thereby adapted to supply air to the lower end of the vertical channel D. The rear lower corner of each chamber C is provided with an outlet-opening, K.

I represents an air-pump which is arranged in front of each chamber B. The said air-pumps are located under the cylindrical portion of the boiler, and are provided at their rear ends with pipes L, which extend from

their cylinders to the lower front sides of the chambers B and communicate with the flues of channels D thereof. In advance of each air-pump I is a guideway, M, for the cross-head N, with which each piston-rod of the air-pump is provided.

O represents one of the axles of the locomotive-truck, which is provided near its center with eccentric P, that extends in diametrically-opposite directions.

R represents pitmen which connect the eccentric to the cross-heads N.

From the foregoing description it will be understood that when the locomotive is in motion the air-pumps will be operated and caused to force air through the channels of the heating-chamber B, from whence the heated air will be supplied to the cars, as will be hereinafter fully described. In order to cause air to be forced through the channels of the heated chambers, and thus heated and supplied to the cars when the train is standing still, I provide additional air-pumps S, which are operated by small steam-engines T.

I do not desire to limit myself to the exact arrangement of the heating-chamber shown in Figs. 1, 2 and 3, as in some instances it may be desirable to locate the heating-chambers above the fire-box, as shown in Fig. 9, or in the water-space of the boiler, as shown in Fig. 10.

In opposite sides of each car U of the train is located a hot-air-radiating chamber, V, the same extending lengthwise in the cars for a suitable distance, and being constructed of sheet or plate metal. The inner sides of the radiating-chamber V are covered by screens, of wire-netting W or other suitable materials, in order to prevent the passengers from coming in contact with the heated surfaces of the radiators and being burned.

X represents horizontal radiating arms or chambers, which are arranged under the seats of the car and communicate at one end with the radiating-chambers V.

Y represents pipes, (shown in Fig. 5,) which are connected to the openings K of the air-heating chambers C and extend from the locomotive rearward beneath the tender and through the baggage and express cars (not shown) to the passenger-cars. The said pipes

Y are of double thickness and are formed each by placing a pipe, Y', into a pipe, Y<sup>2</sup>, of somewhat greater diameter.

Each radiating-chamber V is provided at 5 opposite ends with downwardly-extending pipes Z, which pass through the bottoms of the cars and have their lower ends bent outward and extended horizontally to the ends of the cars. The extremities of the said pipes Z 10 are provided with suitable coupling-heads (not shown) to enable the pipes to connect the radiating-chambers together between the cars and to connect the radiating-chamber in the 15 locomotive. By this means the hot air from the locomotive may be carried throughout the entire train and supplied to the radiating-chambers V in the car.

The radiating-chambers V are provided 20 with registers or valves K', by means of which the hot air may be admitted directly to the interior of the cars when necessary in order to warm the same in a short time. From each end of the chambers V extend vertical pipes 25 L', which pass through the roofs of the cars and are provided at their upper ends with swivel eduction-cones M'. Valves or dampers N' are arranged in the pipes L', and similar valves, O', are arranged at the inner ends of the pipes 30 Z, thereby enabling the hot air to be cut off in any car, and also controlling the escape of the heated air from the radiating chambers.

The operation of my invention is as follows: 35 When the train is in motion, air is drawn into the vertical flues of channels D of the heating-chambers B through the funnels H, and is also forced into the heating-chambers by the air-pump, as previously described. As the air passes backward and forward through the 40 tortuous flues or channels of the chambers C, it becomes very thoroughly heated and is forced rearward through the coupling-pipes into the radiators in the cars. The valves N' in the intermediate cars are closed to prevent the

escape of the heated air, the valves O' are open 45 to permit the hot air to circulate through all the radiators in the train, and the radiators in the rear car have their forward valves, N' and O', closed and their rearward valve open, thus 50 permitting the hot air to escape only from the rear ends of the radiators in the last car of the train. Owing to the motion of the train, partial vacuums are formed in the eduction 55 funnels or cones M', thereby accelerating the escape of the hot air and consequently assisting the same to circulate throughout the series of radiators in the train.

Having thus described my invention, I claim—

1. In a car-heater, the combination, with the 60 heating-chambers and the conveying-pipes leading therefrom, of the radiators connected to the said conveying-pipes, the pipes Z, provided with the valves O', and the vertical 65 pipes L', having valves N', and cones or funnels M', as set forth.

2. In heating apparatus for railway-cars, the radiators V, arranged in the sides of the 70 cars and having communicating horizontal arms X, extending under the seats, substantially as described.

3. In heating apparatus for railway-cars, the heating-chambers C, arranged in the locomotive-furnace and having the tortuous communicating flues or channels D E, and means to 75 supply the same with air, in combination with the radiators arranged in the sides of the cars, coupled together in series and connected to and communicating with the heating-chambers, 80 substantially as described.

In testimony that I claim the foregoing as my own I have hereto affixed my signature in presence of two witnesses.

ALBERT RHODES THOMPSON.

Witnesses:

S. B. HOFFMEIER,  
JOHN B. OTTO.