

J. P. CONNELL.

Improvement in Door-Bells.

No. 132,199.

Patented Oct. 15, 1872.

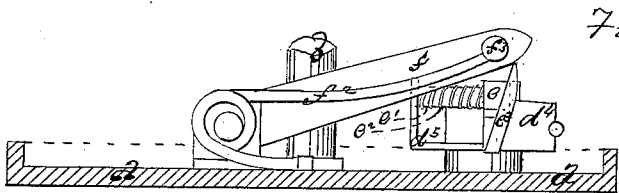
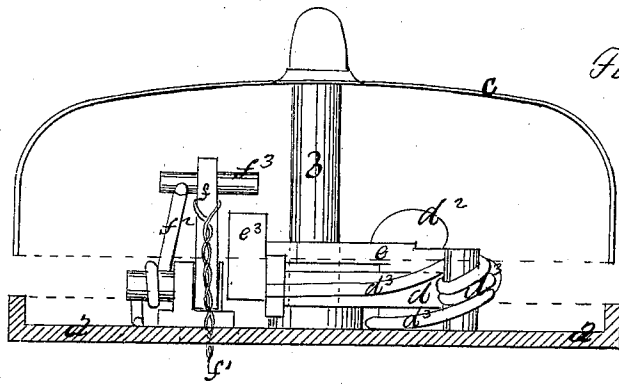
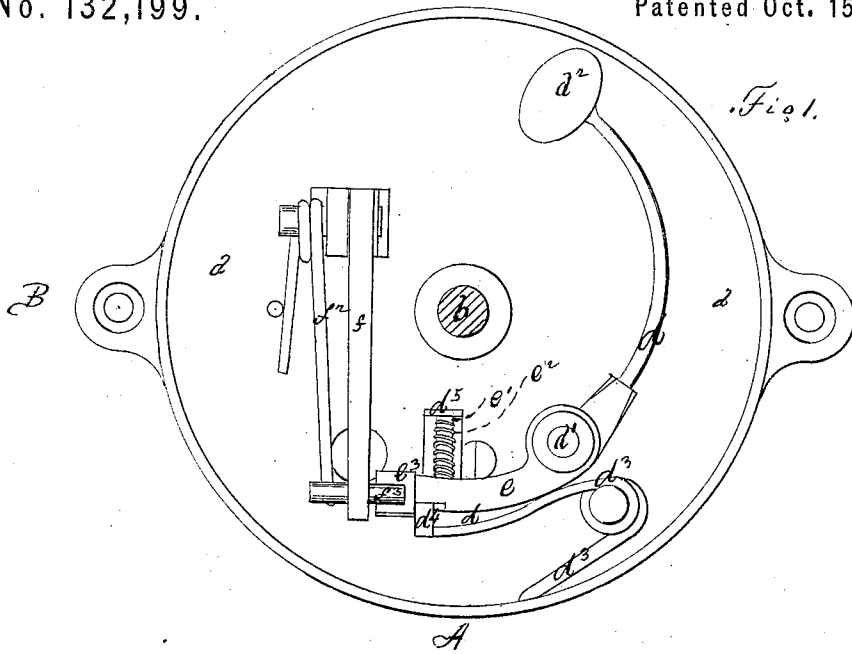

Witnesses:
T. E. Stelle
E. G. Fuller.

Inventor.
John P. Connell
By W. E. Simonds
Att.

UNITED STATES PATENT OFFICE.

JOHN P. CONNELL, OF KENSINGTON, CONNECTICUT.

IMPROVEMENT IN DOOR-BELLS.

Specification forming part of Letters Patent No. 132,199, dated October 15, 1872.

To all whom it may concern:

Be it known that I, JOHN P. CONNELL, of Kensington, in the county of Hartford and State of Connecticut, have invented certain new and useful Improvements in Door-Bells, of which the following is a specification, reference being had to the accompanying drawing, in which—

Figure 1 is a plan or top view of the bell with its concave sounding-shell removed, so as to show the interior working mechanism; Fig. 2 is a side elevation of the same from the side A, showing, also, the sounding-shell, and representing it and the base-plate as cut in section; and Fig. 3 is a side elevation of the same from the side B, but without the sounding-shell.

This invention is an improvement in that class of door-bells which are operated by a pull-wire running through the back or base-plate of the bell.

The letter *a* indicates the base-plate, and *b* the pillar supporting the sounding-shell *c*. The letter *d* indicates the hammer-arm, pivoted on the pin *d*¹, and *d*² is the hammer-head. *d*³ is the spring which gives throw to the hammer-arm. Overlying the hammer-arm is the cam-lever *e*, pivoted on the pin *d*¹, its back striking against the stop *d*⁴ affixed to the hammer-arm, so that the cam-lever can swing no

further outward than indicated by its position in the drawing. From the inner side of the cam-lever a pin, *e*¹, projects, running through the guide *d*⁵, and on this pin is the spiral compression-spring *e*², tending to keep the cam-lever always against the stop *d*⁴. On the end of the cam-lever is the cam *e*³. The letter *f* indicates the pull-wire lever, and *f*¹ is the pull-wire running through a hole in the base-plate. *f*² is a spring tending to keep the lever *f* always in the position shown in the drawing.

When the lever *f* is pulled down it presses past the cam *e*³, carrying back the hammer-arm for a stroke, and when the pin *f*³ passes by the cam the hammer is tripped and sounds the bell. The spring *f*² carries the lever *f* back to position, the pin *f*³ passing up on the opposite side of the cam, the spring *e*² allowing it to give way for this purpose.

I claim as my invention—

The combination of the hammer-arm *d*, the cam-lever *e* and cam *e*³, and the pull-wire lever *f*, all constructed and operating substantially as described, for the purpose set forth.

JOHN P. CONNELL.

Witnesses:

E. W. MORGAN,
THERON UPSON.