

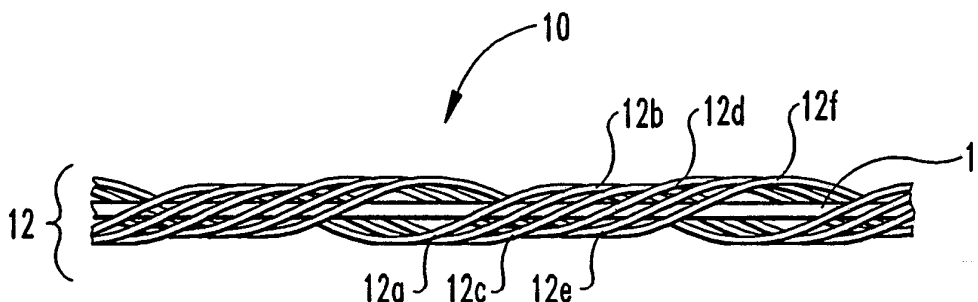

INTERNATIONAL APPLICATION PUBLISHED UNDER THE PATENT COOPERATION TREATY (PCT)

<p>(51) International Patent Classification ⁵ : A61B 17/22</p>	<p>A1</p>	<p>(11) International Publication Number: WO 92/22254 (43) International Publication Date: 23 December 1992 (23.12.92)</p>
<p>(21) International Application Number: PCT/US92/05183 (22) International Filing Date: 16 June 1992 (16.06.92) (30) Priority data: 715,987 17 June 1991 (17.06.91) US (71) Applicant: WILSON-COOK MEDICAL, INC. [US/US]; 4900 Bethania Station Road, Winston-Salem, NC 27105 (US). (72) Inventors: GIBBS, Rebecca, Copenhaver ; 4900 Beaverdale Drive, Greensboro, NC 27406 (US). MARTEL, Mark, Curran ; 54 Carrisbrooke Lane, Winston-Salem, NC 27104 (US). FREMUND, Zdenek, Anthony ; #4 Surrey Lane, Montvale, NJ 07645 (US).</p>		<p>(74) Agents: WAGNER, Vincent, O. et al.; Woodard, Emhardt, Naughton, Moriarty & McNett, Bank One Center/Tower, Suite 3700, 111 Monument Circle, Indianapolis, IN 46204 (US). (81) Designated States: AT (European patent), AU, BE (European patent), CA, CH (European patent), DE (European patent), DK (European patent), ES (European patent), FR (European patent), GB (European patent), GR (European patent), IT (European patent), JP, LU (European patent), MC (European patent), NL (European patent), SE (European patent). Published <i>With international search report.</i></p>

(54) Title: ENDOSCOPIC EXTRACTION DEVICE HAVING COMPOSITE WIRE CONSTRUCTION



(57) Abstract

Disclosed herein is an endoscopic extraction device which retains its operative usefulness for longer periods of time, and therefore needs to be replaced less frequently. This extended instrument life is accomplished through the use of a composite wire construction, which includes an inner monofilament wire (11) of nitinol material surrounded by six stranded stainless steel wires (12a-f). A wire construction in which a nitinol wire (21) is surrounded by five stranded stainless steel wires (22a-e) is also disclosed. After constructing a wire basket in the normal manner using this material, heat is applied to the formed basket in its pre-formed shape to set the memory characteristics of the inner nitinol core.

FOR THE PURPOSES OF INFORMATION ONLY

Codes used to identify States party to the PCT on the front pages of pamphlets publishing international applications under the PCT.

AT	Austria	FI	Finland	MI	Mali
AU	Australia	FR	France	MN	Mongolia
BB	Barbados	GA	Gabon	MR	Mauritania
BE	Belgium	GB	United Kingdom	MW	Malawi
BF	Burkina Faso	GN	Guinea	NL	Netherlands
BG	Bulgaria	GR	Greece	NO	Norway
BJ	Benin	HU	Hungary	PL	Poland
BR	Brazil	IE	Ireland	RO	Romania
CA	Canada	IT	Italy	RU	Russian Federation
CF	Central African Republic	JP	Japan	SD	Sudan
CG	Congo	KP	Democratic People's Republic of Korea	SE	Sweden
CH	Switzerland	KR	Republic of Korea	SN	Senegal
CI	Côte d'Ivoire	LI	Liechtenstein	SU	Soviet Union
CM	Cameroon	LK	Sri Lanka	TD	Chad
CS	Czechoslovakia	LU	Luxembourg	TG	Togo
DE	Germany	MC	Monaco	US	United States of America
DK	Denmark	MG	Madagascar		
ES	Spain				

-|-

ENDOSCOPIC EXTRACTION DEVICE HAVING COMPOSITE WIRE CONSTRUCTION

BACKGROUND OF THE INVENTION

5 Field of the Invention: The field of this invention is medical extraction devices, particularly such devices which are used to endoscopically remove foreign bodies from a patient.

10 Description of the Prior Art: In the medical field of gastroenterology, extraction devices are commonly used to endoscopically incise and/or grasp and remove foreign bodies from a patient. For example, a wire basket stone extractor might be used to extract gallstones from the bile duct of a patient. In such an operation, the stone extractor would be
15 advanced through an endoscope, with its wire basket retracted within a retaining cannula. Once advanced, the wire basket would then be extended out of the retaining cannula, with the basket wires opening up into their pre-formed basket configuration. The basket is then manipulated to grasp and
20 remove the gallstones from the patient.

 The wire material used in prior art wire basket stone extractors and the like has most commonly been either monofilament or stranded stainless steel wire, and has generally been found to be satisfactory for the purpose
25 intended. The stainless steel wire retains its pre-formed orientation, and returns to its basket configuration when extended from its retaining cannula, even after repeated use. After extended periods of non-use or after long-term repeated use, however, these wire baskets slowly tend to lose
30 their pre-formed orientation, and eventually need to be replaced. The medical art in this area would benefit from an improved extraction device which holds its designed orientation longer and more precisely, and which therefore has to be replaced less frequently.

-2-

SUMMARY OF THE INVENTION

The present invention makes available to the medical practitioner endoscopic extraction devices which retain their operative usefulness for longer periods of time, and therefore need to be replaced less frequently. This extended instrument life is accomplished through the use of a composite wire construction, which includes, according to one embodiment, an inner monofilament wire of nitinol material surrounded by six stranded stainless steel wires. In a second disclosed embodiment, the inner nitinol wire is surrounded by five stranded stainless steel wires. After constructing, for example, a wire basket in the normal manner using this material, heat is applied to the formed basket in its pre-formed shape to set the memory characteristics of the inner nitinol core. The result is a durable wire basket which is easy to construct and which maintains its operative usefulness, even after continuous repeated use over long periods of time, or after extended periods of non-use.

BRIEF DESCRIPTION OF THE DRAWINGS

FIG. 1a is schematical view of a 1x7 stranding configuration used in the present invention, wherein a central wire of nitinol material is surrounded by six
5 stranded stainless steel wires. FIG. 1b shows a cross-sectioned view of the composite construction illustrated in FIG. 1a.

FIG. 2a is schematical view of a 1x6 stranding configuration used in the present invention, wherein a
10 central wire of nitinol material is surrounded by five stranded stainless steel wires. FIG. 2b shows a cross-sectioned view of the composite construction illustrated in FIG. 2a.

FIG. 3 is a partial fragmentary and partially
15 cross-sectioned illustration of a wire basket stone extractor according to the present invention, with wire basket 77 retained within retaining cannula 79.

FIG. 4 is a illustration of the wire basket stone
20 extractor of FIG. 3, with wire basket 77 extended out from retaining cannula 79 and into its preformed basket configuration.

-4-

DESCRIPTION OF THE PREFERRED EMBODIMENT

For the purposes of promoting an understanding of the principles of the invention, reference will now be made to the embodiments illustrated in the drawings and specific language will be used to describe the same. It will nevertheless be understood that no limitation of the scope of the invention is thereby intended, such alterations and further modifications in the illustrated device, and such further applications of the principles of the invention as illustrated therein being contemplated as would normally occur to one skilled in the art to which the invention relates.

Referring now to the drawings, FIG. 1a is schematical view of an extraction wire 10 formed in a 1x7 configuration, wherein a central wire 11 of nitinol material is surrounded by stranding 12 of six stranded stainless steel wires 12a-f. The spacing between wiring, as shown by the FIG. 1a, is for illustration purposes to show the relative orientation of the wiring, and does not occur in extraction wire 10, as actually constructed. The stranded construction of extraction wire 10 has a right hand lay .053". Inner wire 11 has a diameter of .005" and surrounding wires 12a-f each have a diameter of .004". The overall diameter of extraction wire 10 is .013". FIG. 1b shows a cross-sectioned view of the composite construction of extraction wire 10.

FIG. 2a is schematical view of a second extraction wire 20 formed in a 1x6 configuration, wherein a central wire 21 of nitinol material is surrounded by a stranding 22 of five stainless steel wires 22a-e. As with FIG. 1a, the spacing between wiring shown by the FIG. 2a is for illustration purposes to show the relative orientation of the wiring, and does not occur in the actually constructed extraction wire 20. The construction of extraction wire 20 has a right hand lay of .082". Inner wire 21 has a diameter of .005" and

surrounding wires 22a-e each have a diameter of .055". The overall diameter of extraction wire 20 is .017". FIG. 1b shows a cross-sectioned view of the composite construction of extraction wire 20.

5 FIGS. 3 and 4, in combination, show the operation of a wire basket stone extractor made according to the present invention. FIG. 3 is a partial fragmentary and partially cross-sectioned illustration of a wire basket stone extractor 70, which includes wire basket assembly 71 and retaining
10 cannula 79. Wire basket assembly 71 includes push rod 72, pushrod/cable solder joint 73, cable 74, proximal basket hub solder joint 75, distal basket hub solder joint 76, and extraction wires 77a-d. Extraction wires 77a-d are made of the composite construction shown for wire 10 in FIGS. 1a-b,
15 and each include a central wire 11 of nitinol surrounded by a stranding 12 of six stainless steel wires 12a-b, as shown and described in relation to wire 10. In FIG. 3, wire basket assembly 71 is shown in its retracted position in relation to retaining cannula 79, with wire basket 77 being held within,
20 and being retained in a collapsed condition by, retaining cannula 79. FIG. 4 illustrates the wire basket stone extractor 70 of FIG. 3, with wire basket 77 extending out from retaining cannula 79 and into its preformed basket configuration for its intended operative purpose. This is
25 accomplished by pushing push rod 72, which movement projects wire basket 77 distally out of retaining cannula 79, allowing wire basket 77 to assume its preformed shape.

The method of construction of wire basket stone extractor 70 will now be discussed with reference to the elements of
30 wire basket stone extractor 70 shown in FIGS. 3 and 4 and the extraction wire construction shown in FIGS. 1a-b. Extraction wires 77a-d are constructed of approximately equal length out of a composite construction which includes an inner monofilament wire 11 of shape memory material (nitinol)
35 surrounded by a stranding 12 of a six stainless steel wires

-6-

12a-f. Extraction wires are joined by soldering stainless steel strands 12 together at one end at push rod/cable solder joint 73 and attached to push rod 71 at joint 73. At the distal end, extraction wires 77a-d are also joined by
5 soldering at stainless steel strands 12 together at distal basket hub soldering joint 76. Extraction wires 77a-d are then also joined at a set position a set distance from the distal end of extraction wires 77a-d by soldering stainless steel strands 12 together at proximal basket hub solder joint
10 75.

Wire basket 77 may then be formed by separating extraction wires 77a-d from each other in the area between proximal basket hub soldering joint 75 and distal basket hub soldering joint 76, and bending extraction wires 77a-d into a
15 desired configuration for use, as shown in FIG. 4. The remaining portion of extraction wires 77a-d between joints 74 and 75 are stranded together to form cable 74. After wire basket 77 has been formed, heat is applied to wire basket 77 to set the shape memory characteristics of inner monofilament
20 wires 11. After cooling, wire basket assembly 71 may then be placed in retaining cannula 79 to complete the assembly of extractor 70.

The shape memory material used in extraction wires 10 and
20 is a nickel titanium alloy known as nitinol, which is composed of about 55% Ni and 44% Ti, with trace elements of
25 Cu (150 ppm), Fe (110 ppm), and Mn (21 ppm). As a shape memory material, nitinol central wires 11 and 21 have the characteristic of superelasticity whereby they exhibit a superelastic tendency to retain the shape in which they are
30 formed when heat is applied to a suitable presetting temperature. This characteristic serves to reinforce the orientation toward the configuration into which extraction wires constructed in this manner are bent to form a wire basket or other extracting configuration, such as a snare.
35 The use of the composite construction with a nitinol inner

-7-

core and surrounding stainless steel strands, as described herein, allows for ease of construction in that the surrounding stainless steel strands 12 and 22 can easily be soldered to each other at joints 73, 75, and 76, whereas
5 nitinol material is not nearly so readily joinable. In addition to the improvements in efficiency of construction and enhanced durability and reliability of operation, the use of the described composite construction also provides a savings in cost of material over the use of a single
10 superelastic material for the forming of extraction wires.

It is to be noted that, while two specific examples of extraction wire construction have been disclosed herein, other configurations are suitable which fall within the scope of this invention. Also, while stainless steel is
15 particularly suited for strands 12 and 22, other materials which are readily joinable relative to shape memory material may satisfactorily serve in an alternative construction. And it is to be further noted that while an example as been provided in which the present invention has been incorporated
20 into a four wire basket, there are many other extraction configurations for wire baskets, stent retrievers, snares etc. in which the present invention is useful. Therefore, while the invention has been illustrated and described in detail in the drawings and foregoing description, the same is
25 to be considered as illustrative and not restrictive in character, it being understood that only the preferred embodiment has been shown and described and that all changes and modifications that come within the spirit of the invention are desired to be protected.

-8-

What is claimed is:

1. In a medical extraction device, said device including a retaining cannula and at least one extraction wire extendable therefrom into a pre-formed configuration for
5 removing a foreign body from within a patient, the improvement comprising constructing said extraction wire out of a composite construction which includes an inner monofilament wire of shape memory material material
10 surrounded by a plurality of stranded wires of material which is readily joinable relative to said shape memory material.

2. The improvement in a medical extraction device according to claim 1 in which said stranded wires are made of stainless steel.

3. The improvement in a medical extraction device
15 according to claim 2 in which said stranded stainless steel wires includes five wires.

4. The improvement in a medical extraction device according to claim 2 in which said stranded stainless steel wires includes six wires.

20 5. The improvement in a medical extraction device according to claim 1 in which said shape memory material is nitinol.

6. The improvement in a medical extraction device according to claim 4 in which said shape memory material is
25 nitinol.

7. The improvement in a medical extraction device according to claim 5 in which said shape memory material is nitinol.

8. The improvement in a medical extraction device according to claim 6 in which said inner wire has a diameter of about .005" and said surrounding wires each have a diameter of about .0055".

5 9. The improvement in a medical extraction device according to claim 7 in which said inner wire has a diameter of about .005" and said surrounding wires each have a diameter of about .0004".

10 10. An improvement in the method for constructing a medical extraction device, said medical extraction device including a retaining cannula and at least one extraction wire extendable therefrom into a pre-formed configuration for removing a foreign body from within a patient, the improvement comprising the steps of:

15 constructing said extraction wire out of a composite construction which includes an inner monofilament wire of shape memory material surrounded by a plurality of stranded wires made from a material which is readily joinable relative to said shape memory material;

20 joining said extraction wire to an extraction assembly by soldering said stranded wires to said extraction assembly;

forming said extraction wire into a desired configuration for use in said medical extraction device; and

25 applying heat to said formed extraction wire to set the shape memory characteristics of said inner monofilament wire of shape memory material.

11. The improvement in the method for constructing a medical extraction device according to claim 10 in which said stranded wires are made of stainless steel.

30 12. The improvement in the method for constructing a

-10-

medical extraction device according to claim 10 in which said shape memory material is nitinol.

13. The improvement in the method for constructing a medical extraction device according to claim 11 in which said 5 stranded stainless steel wires includes five wires.

14. The improvement in the method for constructing a medical extraction device according to claim 11 in which said stranded stainless steel wires includes six wires.

15. The improvement in the method for constructing a 10 medical extraction device according to claim 13 in which said shape memory material is nitinol.

16. The improvement in the method for constructing a medical extraction device according to claim 14 in which said shape memory material is nitinol.

15 17. The improvement in the method for constructing a medical extraction device according to claim 15 in which said inner wire has a diameter of about .005" and said surrounding wires each have a diameter of about .0055".

18. The improvement in the method for constructing a 20 medical extraction device according to claim 16 in which said inner wire has a diameter of about .005" and said surrounding wires each have a diameter of about .0004".

19. An improvement in the method for constructing a medical extraction device, said medical extraction device 25 including a retaining cannula and a plurality of extraction wires extendable therefrom into a pre-formed configuration for removing a foreign body from within a patient, the improvement comprising the steps of:

constructing a plurality of extraction wires of

-11-

approximately equal length out of a composite construction which includes an inner monofilament wire of shape memory material surrounded by a plurality of stranded wires of material which is readily joinable relative to said shape
5 memory material;

joining the ends of said extraction wires by soldering said stranded wires together at said ends;

joining said extraction wires at a set position a set distance from the distal end of said extraction wires by
10 soldering said stranded wires together at said set position;

forming said extraction wires in the area between said set position and the distal end of said extraction wires into a desired configuration for use in said medical extraction device; and

15 applying heat to said formed extraction wires to set the shape memory characteristics of said inner monofilament wire of shape memory material.

20. The improvement in the method for constructing a medical extraction device according to claim 19 in which said
20 stranded wires are made of stainless steel.

21. The improvement in the method for constructing a medical extraction device according to claim 20 in which said stranded stainless steel wires includes five wires.

22. The improvement in the method for constructing a
25 medical extraction device according to claim 20 in which said stranded stainless steel wires includes six wires.

23. The improvement in the method for constructing a medical extraction device according to claim 19 in which said shape memory material is nitinol.

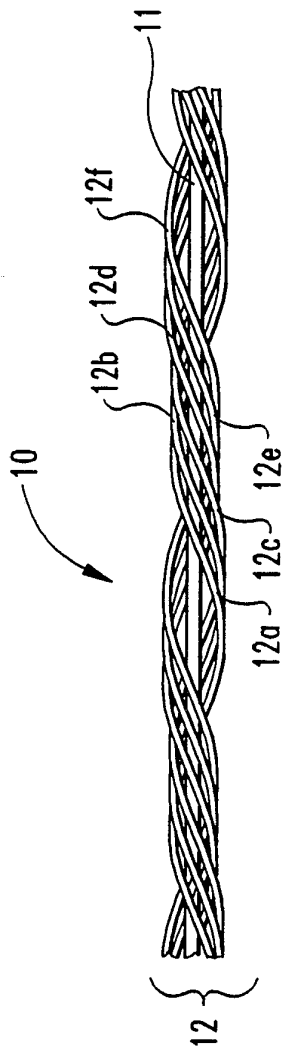

Fig. 1a

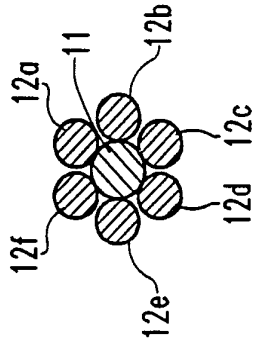

Fig. 1b

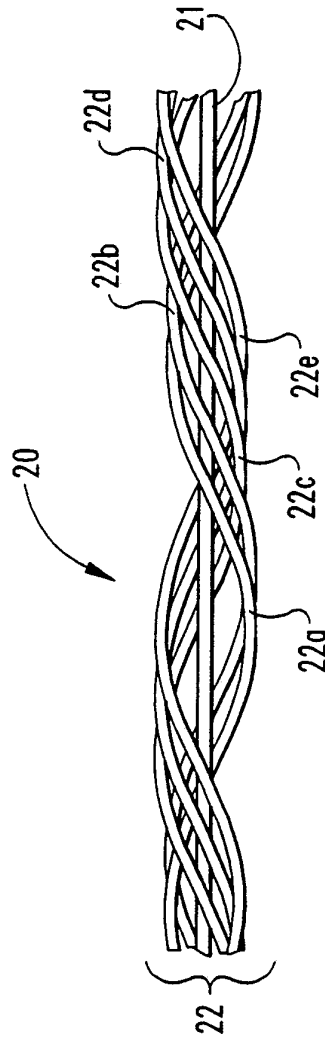

Fig. 2a

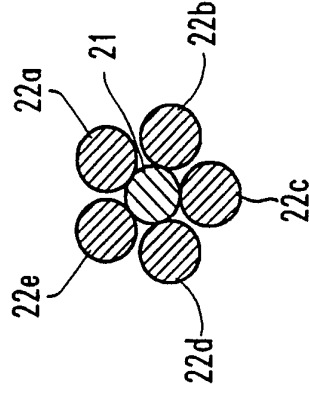

Fig. 2b

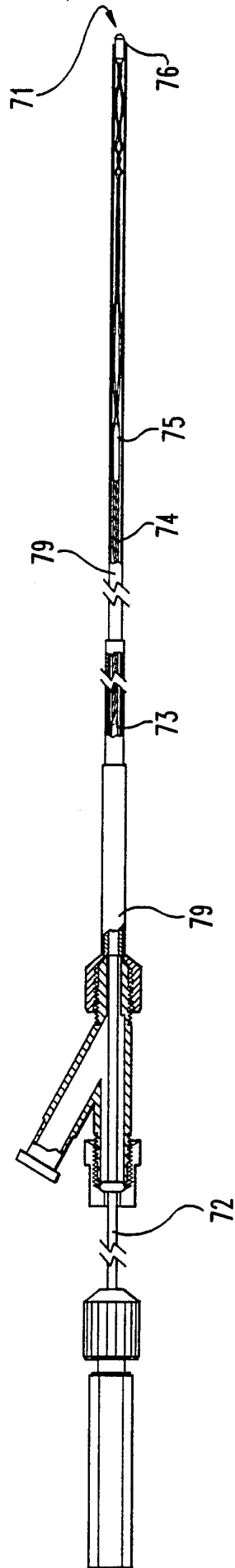

Fig. 3

2/2

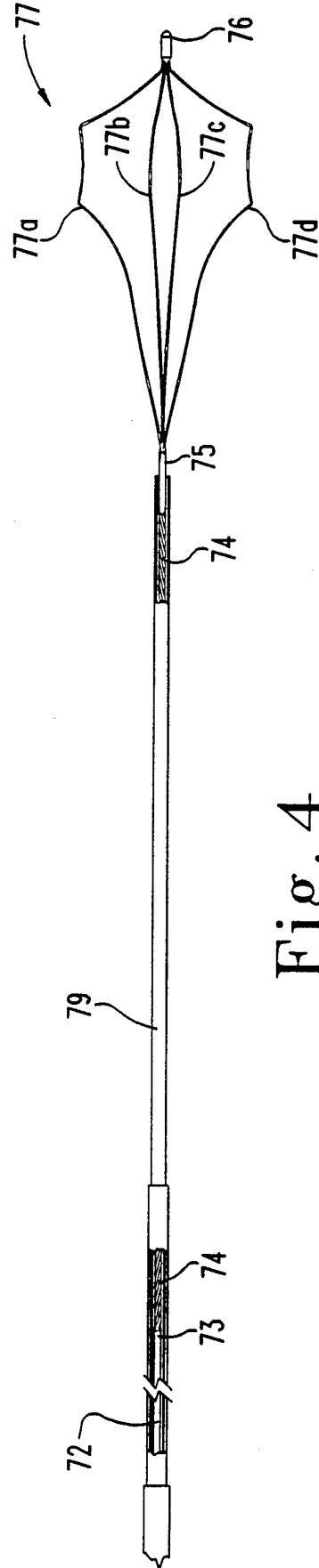

Fig. 4

INTERNATIONAL SEARCH REPORT

International application No.
PCT/US92/05183

A. CLASSIFICATION OF SUBJECT MATTER
IPC(5) :A61B 17/22
US CL :606/127
According to International Patent Classification (IPC) or to both national classification and IPC

B. FIELDS SEARCHED
Minimum documentation searched (classification system followed by classification symbols)
U.S. : 606/127, 113

Documentation searched other than minimum documentation to the extent that such documents are included in the fields searched
none

Electronic data base consulted during the international search (name of data base and, where practicable, search terms used)
none

C. DOCUMENTS CONSIDERED TO BE RELEVANT

Category*	Citation of document, with indication, where appropriate, of the relevant passages	Relevant to claim No.
X,P Y	US,A, 5,064,428 (COPE ET AL) 12 NOVEMBER 1991 (SEE ENTIRE DOCUMENT)	1-18 19-23
Y,P	US,A, 5,098,441 (WECHLER) 24 MARCH 1992 (SEE ENTIRE DOCUMENT)	19-23

Further documents are listed in the continuation of Box C. See patent family annex.

* Special categories of cited documents:	"T" later document published after the international filing date or priority date and not in conflict with the application but cited to understand the principle or theory underlying the invention
"A" document defining the general state of the art which is not considered to be part of particular relevance	"X" document of particular relevance; the claimed invention cannot be considered novel or cannot be considered to involve an inventive step when the document is taken alone
"E" earlier document published on or after the international filing date	"Y" document of particular relevance; the claimed invention cannot be considered to involve an inventive step when the document is combined with one or more other such documents, such combination being obvious to a person skilled in the art
"L" document which may throw doubts on priority claim(s) or which is cited to establish the publication date of another citation or other special reason (as specified)	"&" document member of the same patent family
"O" document referring to an oral disclosure, use, exhibition or other means	
"P" document published prior to the international filing date but later than the priority date claimed	

Date of the actual completion of the international search 22 JULY 1992	Date of mailing of the international search report 23 SEP 1992
---	--

Name and mailing address of the ISA/ Commissioner of Patents and Trademarks Box PCT Washington, D.C. 20231 Facsimile No. NOT APPLICABLE	Authorized officer <i>Michael Thaler</i> MICHAEL THALER Telephone No. (703) 308-2981
---	--