

P. M. RANDALL.
Quartz Mill.

No. 40,854.

Patented Dec. 8, 1863.

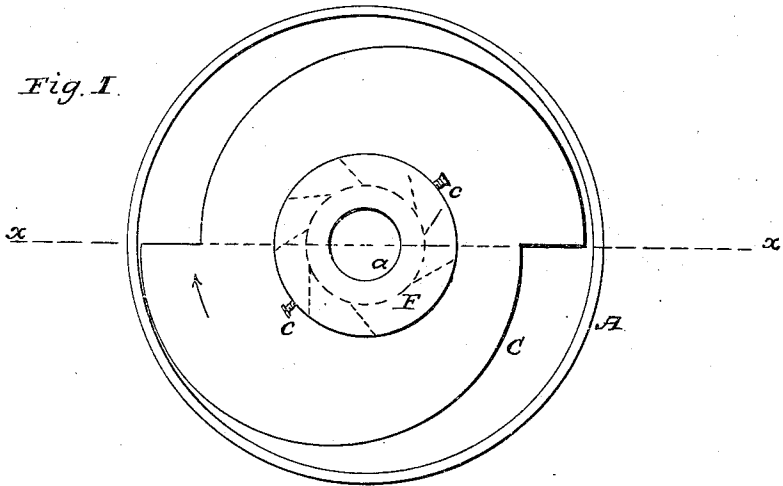

Fig. 2.

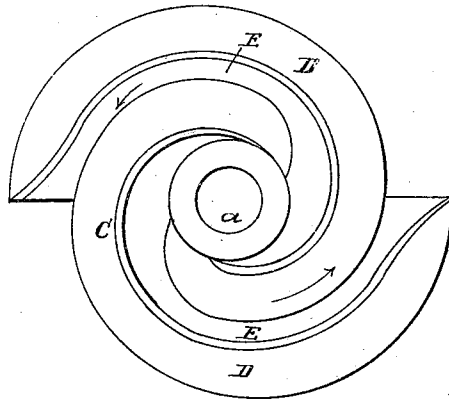
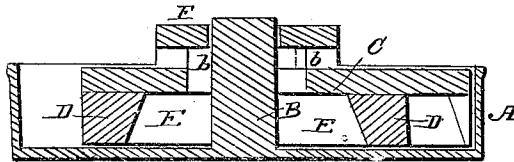

Fig. 3.



witnesses:
J. W. Coombs
W. B. Reed

Inventor:
P. M. Randall
By *Munn & Co*
attys

UNITED STATES PATENT OFFICE.

PHINEAS M. RANDALL, OF SAN FRANCISCO, CALIFORNIA.

IMPROVEMENT IN QUARTZ MILLS OR CRUSHERS.

Specification forming part of Letters Patent No. 40,854, dated December 8, 1863.

To all whom it may concern:

Be it known that I, PHINEAS M. RANDALL, of San Francisco, in the county of San Francisco and State of California, have invented a new and improved rotary muller, designed more especially for the reduction of quartz and the amalgamation of metals contained therein; and I do hereby declare that the following is a full, clear, and exact description of the same, reference being had to the accompanying drawings, making a part of this specification, in which—

Figure 1 is a plan or top view of my invention fitted in a pan; Fig. 2, a detached inverted plan or face view of the same; Fig. 3, a vertical section of Fig. 1, taken in the line *x x*.

Similar letters of reference indicate corresponding parts in the several figures.

The object of this invention is to obtain a muller which will operate in such a manner as to subject the article being ground or reduced to a continuous operation until the article is reduced to the desired degree of comminution.

The invention is applicable to the reduction of most substances to a pulpy or pasty consistency, but is more especially designed for the reduction of quartz and the amalgamation of the metals contained therein.

To enable those skilled in the art to fully understand and construct my invention, I will proceed to describe it.

A, Figs. 1 and 2, represents a circular pan provided at its center with an upright hub, B, and C represents a muller which has a circular opening, *a*, at its center to receive the hub B of the pan A or allow the hub to pass through the muller.

D D represent grinding-plates on the face of the muller, and E E are grooves which are between the grinding-plates D D, said grooves as well as the grinding-plates being of spiral or involute form, as shown clearly in Fig. 2. The top or upper surface of the muller is perfectly smooth, and has a ring, F, attached to it by standards *b*, the hub B passing through the ring and preventing the muller having any lateral play or vibration. The ring F has

gudgeons *c* attached to it, to which the driving mechanism is attached. The opening *a* at the center of the muller C is larger than that in the ring F, and a space is allowed between the hub B and the opening *a*, as shown clearly in Fig. 3. The pan A is rather greater in diameter than the muller C, and both the pan and muller are of iron, the muller being of sufficient thickness to have the requisite weight for crushing the substances to be operated upon. The grinding-plates D D may be made or cast separate from the muller-plate (designated by D') and secured thereto by bolts or in any proper way. The muller is rotated in the direction indicated by the arrow, and the pulp or substance in the pan underneath the muller will be forced from the periphery of the latter toward its center, owing to the involute grooves E E, and will be subjected to a grinding action or process by the plates D D. The pulp, as it reaches the center of the muller, is forced upward around the hub B of the pan A and out through the spaces between the standards *b*, and is then by centrifugal force expelled outward to the periphery of the muller, and passes down again underneath the muller, to be again forced toward its center. Thus it will be seen that the substance in the pan is continually subjected to a grinding action, which may be prolonged until the desired degree of comminution is attained.

Having thus described my invention, what I claim as new, and desire to secure by Letters Patent, is—

A rotary muller provided at its face side with grooves of involute or other form, which will convey or force the substance acted upon from the periphery of the muller toward its center, and thence upward through the muller, so that the substance may be expelled by centrifugal force toward the periphery of the muller, and then pass down again underneath the muller to be forced toward its center as before, as herein set forth.

PHINEAS M. RANDALL.

Witnesses:

JAS. F. HUBBARD,
HENRY HAIGHT.