

No. 637,604.

Patented Nov. 21, 1899.

E. HETT.  
PRESS.

(Application filed Jan. 5, 1899.)

(No Model.)

4 Sheets—Sheet 1.

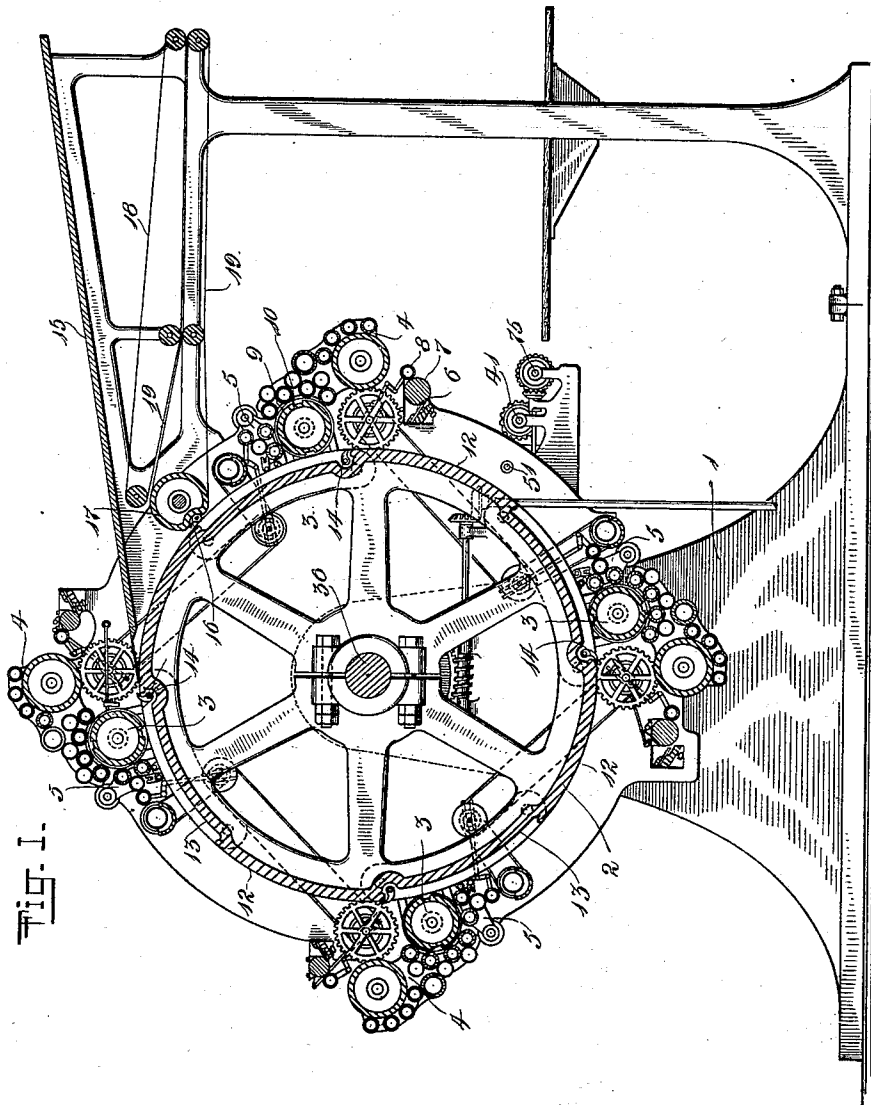

WITNESSES:

*Frederick M. Mann*  
*Sidney Mann*

INVENTOR

*Edward Hett*

BY

*Kerrison & Kerrison*  
ATTORNEYS

No. 637,604.

Patented Nov. 21, 1899.

E. HETT.  
PRESS.

(Application filed Jan. 5, 1899.)

(No Model.)

4 Sheets—Sheet 2.

FIG. 2.

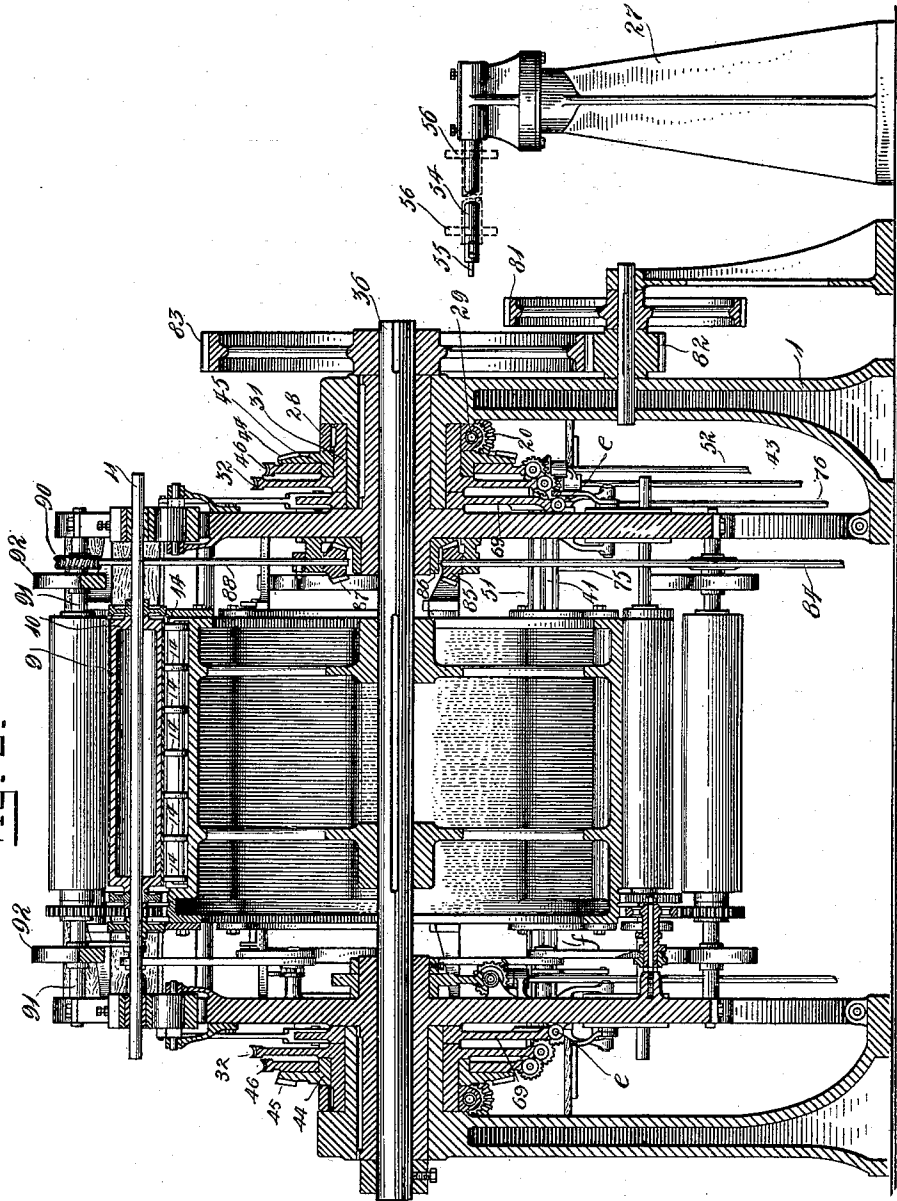

WITNESSES:

*Geo. W. Pillsbury*  
*Sidney Mann*

INVENTOR

*Edward Hett*

BY

*Kerrison & Kerrison*  
ATTORNEYS

No. 637,604.

Patented Nov. 21, 1899.

E. HETT.  
PRESS.

(Application filed Jan. 5, 1899.)

(No Model.)

4 Sheets—Sheet 3.

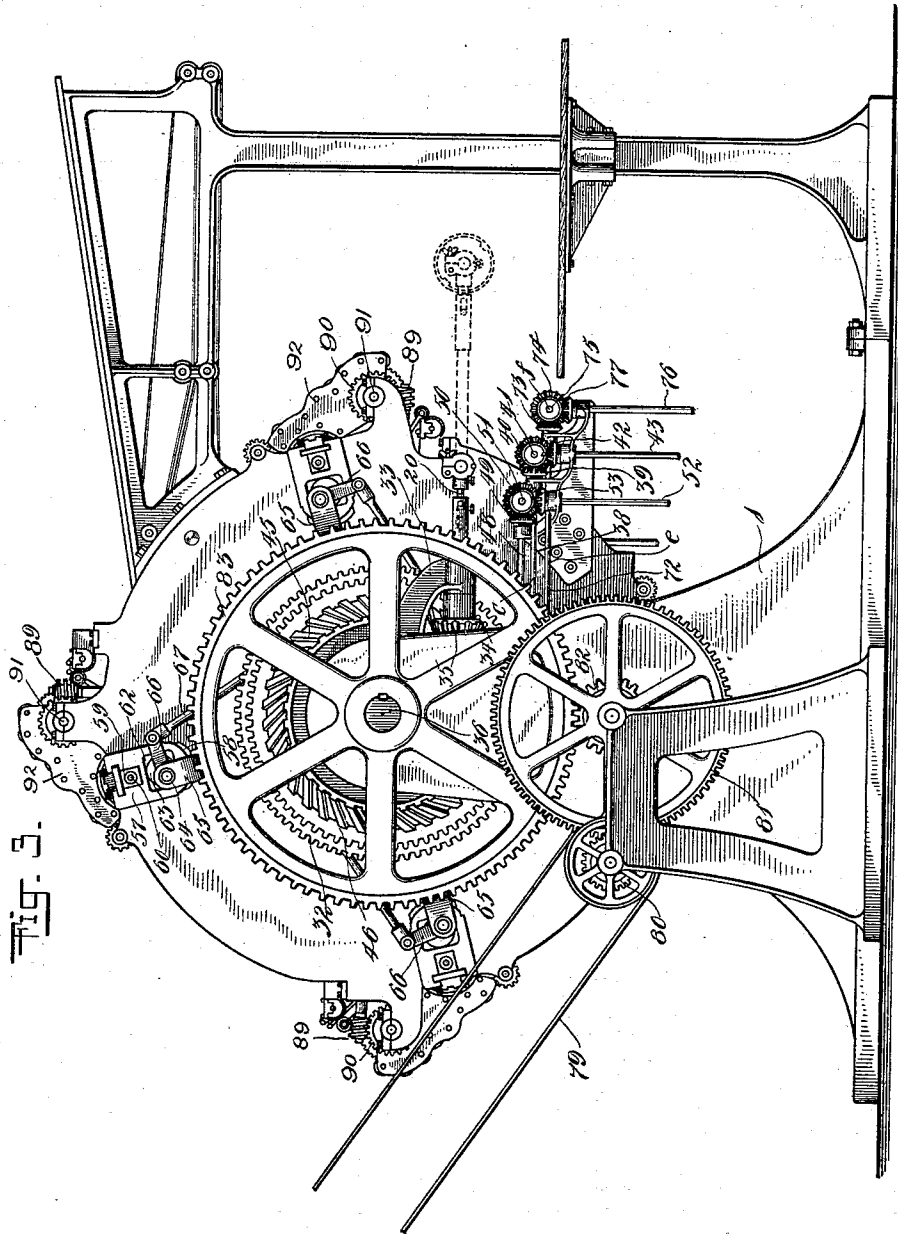

WITNESSES:

*Frederick W. [Signature]*  
*Sidney [Signature]*

INVENTOR

*Edward Hett*

BY

*Kennon & Kennon*  
ATTORNEYS

No. 637,604.

Patented Nov. 21, 1899.

E. HETT.  
PRESS.

(Application filed Jan. 5, 1899.)

(No Model.)

4 Sheets—Sheet 4.

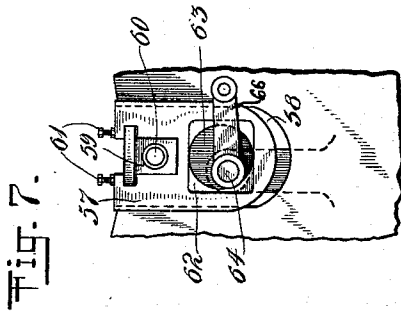
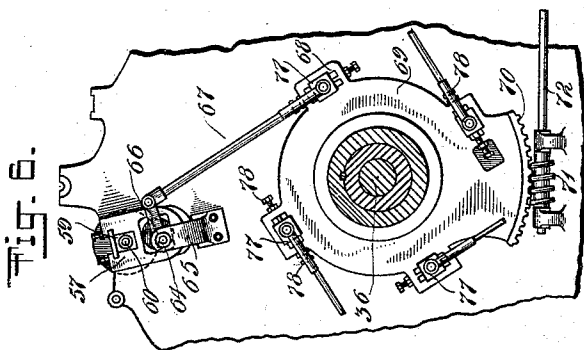
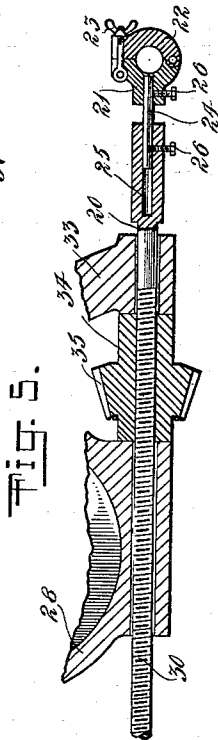
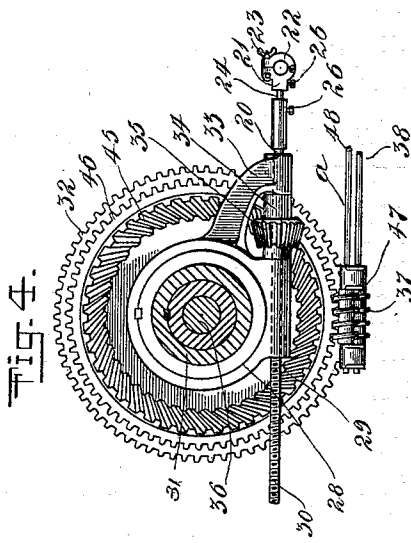
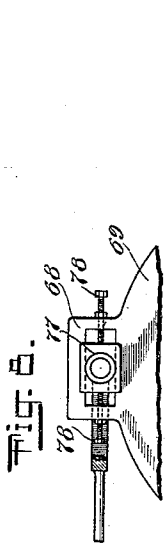

WITNESSES:  
*Geoff Milby*  
*Sidney Frank*

INVENTOR  
*Edward Hett*  
 BY  
*Kerrison & Kerrison*  
 ATTORNEYS

# UNITED STATES PATENT OFFICE.

EDWARD HETT, OF NEW YORK, N. Y.

## PRESS.

SPECIFICATION forming part of Letters Patent No. 637,604, dated November 21, 1899.

Application filed January 5, 1899. Serial No. 701,194. (No model.)

*To all whom it may concern:*

Be it known that I, EDWARD HETT, of New York, (New Dorp,) in the county of Richmond and State of New York, have invented a new and useful Improvement in Presses, of which the following is a specification.

My invention relates to printing and transfer presses.

It has for its object to improve and simplify the means for handling printing-cylinders or printing-tubes or supports therefor, particularly in connection with their introduction into and removal from operative position in the press, to enable such handling means to be arranged and located in the press itself, and to dispense with external means for introducing and removing printing-cylinders, tubes, or supports, such as movable carriages moving upon rails exterior to or surrounding the press.

It also has for its object to provide improved and more efficient means for adjusting the pressure between printing and impression cylinders and to provide means for this purpose which are capable of finer and more delicate adjustment.

My invention consists of the novel devices and combinations of parts herein shown and described.

The preferred form of my invention, which is shown in the drawings herein, is shown in connection with a multicolor-printing press, although obviously my invention can be used with any kind of printing or transfer process in which one or more printing-cylinders, tubes, or supports therefor are used.

In the accompanying drawings, which form a part hereof, and which show the preferred form of my improved device, and in which the same reference characters in the different views refer to corresponding parts, Figure 1 is a vertical section through a multicolor-press embodying one form of my invention, the section being taken at right angles to the axis of the impression-drum. Fig. 2 is a longitudinal vertical section in the plane of the axis of the impression-drum. Fig. 3 is a side elevation of the press, viewed as shown by the arrow in Fig. 2, with the removing standard omitted. Figs. 4 and 5 are detailed sectional views showing a carrier-arm and its support and connecting mechan-

ism, and Figs. 6, 7, and 8 are detailed views of the pressure devices.

Heretofore in inserting printing-cylinders, tubes, or supports therefor into their places in a press or in removing them therefrom it has been necessary either to do this work entirely by hand or by means of handling devices exterior to the press—such, for example, as the movable carriage mounted upon rails shown and described in certain earlier applications of mine. As such printing-cylinders, tubes, or supports therefor are generally of great size and weight, their introduction into the press and removal therefrom by hand involve great labor and a considerable expenditure of time and money. Exterior devices for handling cylinders and the like cannot always be employed by reason of lack of space or for other causes, and they are, moreover, themselves cumbersome and heavy, occupy a large amount of space, and are expensive to construct. In my improved devices I use carrier-arms for carrying printing-cylinders, tubes, or supports therefor to their proper places in the press or for carrying them from their places in the press to a suitable and convenient place of delivery, from whence they may be removed. The carrier-arms are mounted centrally in the press in or upon suitable supports and are adapted to have a revolving motion relative to the press and also to have a radial movement, by means of which combined movements the carrier-arms may be moved to any required position in the press, so as to carry a printing-cylinder, tube, or support therefor to any desired position in the press or to remove it from such position to any convenient delivery-point. In the preferred form of my device I mount the carrier-arms in supports which are adapted to revolve around the shaft of the press, thus imparting a revolving motion to the carrier-arms, and the carrier-arms and supports are so constructed and arranged that the carrier-arms are free to move longitudinally in the supports, thus imparting to the carrier-arms a radial movement relative to the press.

My improved devices for handling printing-cylinders, tubes, or supports therefor are those contained within the body of the press itself. They dispense with the necessity of

the manual work of inserting and removing them, and they dispense with the necessity of using any exterior handling device. My improved devices, moreover, are simple and compact in construction, efficient in operation, and are easily operated and controlled.

My improved devices are shown in connection with a sheet-printing press. It is obvious that they are applicable to a press in which a continuous web is employed.

Referring to the specific forms of apparatus shown in the drawings, 1 indicates the frame of a multicolor sheet-printing press, of which 2 is the impression-drum. 3 3 are printing-cylinders in position in the press. 4 4 are the inking-frames carrying the usual ink-rollers, and 5 5 the dampening-frames carrying the usual dampening-rollers of a lithograph-press. Connected with the inking-rollers are the ink-fountains 6, ink-fountain rollers 7, and ink-daubers 8. As the inking and dampening mechanisms are of the kind usually-employed in similar presses and as their construction forms no part of the present invention, they will not be further described.

The printing-surfaces may be of any suitable form or construction. As shown, they are cylindrical, and consist of an exterior hollow printing tube or shell 9, mounted upon an interior hollow form or support 10, the latter being mounted upon a permanent shaft 11 of the press. As constructed printing-tube 9 is removable from the support 10 and the latter is removable from shaft 11. As far as the present invention, however, is concerned, the printing-surface may be of any form or shape, and, if cylindrical, may be solid or may consist of a printing-tube, as shown.

Any suitable impression-drum of any form, size, or construction may be used. In the form shown in the drawings it consists of a large drum having a number of impression-surfaces 12, arranged to make contact at the proper times with the different printing-surfaces, with intervening depressed places 13 and suitable grippers 14 14 for seizing the sheets of paper as the same come from the feeding-table 15 and for carrying them around the surface of the impression-drum. The sheets after passing around the impression-drum are seized by grippers 16, mounted upon wheel 17, and are carried by the wheel to endless tapes 18 and 19, which pin it between them and deliver it at the right hand of the machine, as shown in Fig. 1.

The devices for squaring the sheet, so as to fit it properly to the press, the devices for driving the impression-drum, printing-cylinders, endless delivery-tapes, and their operating wheels and rollers, and the devices for actuating the dampening and inking mechanisms are the same as those usually employed in sheet-presses of the character of the one shown herein, and as these devices form no part of my present invention they are not

shown in full detail and will not be further described.

I will now proceed to describe my improved devices for handling printing-cylinders, tubes, or supports therefor as the same are shown in the drawings.

20 are carrier-arms for grasping, holding, and carrying printing-cylinders, tubes, or supports therefor. For this purpose they are provided at one end with clamping devices which consist of a fixed part 21 and a swinging part 22, pivoted to the fixed part, two parts being cut out, so that when brought together, as in Fig. 5, they are adapted to hold the end of the shaft of a printing-cylinder, tube, or support. The parts are locked together by means of a screw bolt and nut 23. For the purpose of inserting in or removing from the carrying-arms the shaft of a printing-cylinder and the like part 22 is unlocked and swung down. If this will not permit the printing-cylinder, tube, or support to be removed from the carrier-arms, the entire end of one or both of the carrier-arms can be removed. For this purpose I preferably construct a carrier-arm with a removable head, as shown in Fig. 5, the head part consisting of the portions 21 and 22. A pin 24 fits into a cylindrical opening 25 in the body of the carrier-arm and a similar cylindrical cavity in the head. By means of set-screws 26 26 the parts can be firmly secured together to form one integral structure, Fig. 5. By unloosening the set-screws the head part of the carrier-arm can be removed, the rod 24 can be slipped back into orifice 25, and the printing-cylinder, tube, or support therefor be removed from the carrier-arms. Where hollow external printing-tubes and hollow forms or supports therefor mounted on the shaft and removable therefrom are used, as shown in the drawings, the printing-tube or support therefor is removed from the carrier-arms to a receiving-standard 27 or are taken from such said standard and transferred to the carrier-arms in a manner presently to be described.

The carrier-arms are mounted in supports 28. These supports 28 are provided with a cylindrical opening 29, adapted to receive the screw-threaded portion 30 of the carrier-arm 20. Supports 28 are keyed to a sleeve 31, loosely mounted around the main shaft of the press. Sleeve 31 carries also a worm-wheel 32. Support 28 also has an arm 33, with an opening through which a carrier also projects. Between the sleeve portion 29 of the support and the arm 33 there is placed a sleeve 34, interiorly screw-threaded and carrying on its outer face a beveled gear-wheel 35. The screw-threaded portion 30 of the carrier-arm 20 is adapted to project through the cylindrical openings in sleeves 29 and 34 and arm 33. Sleeve 34, with its beveled gear-wheel 35, is free to rotate between sleeve 29 and arm 33, but is withheld from longitudinal motion by means of the sleeve and arm, which act as

stops. It therefore acts as a nut, and when it revolves by reason of its interior screw-threads and the exterior screw-threads upon carrier-arm 20 it imparts motion to carrier-arm 20 through sleeves 29 and 34 and arm 33 in one direction or the other, depending upon the direction of the rotation of sleeve 33 and beveled gear 35.

Supports 28 are free to revolve in one direction or the other around the main shaft 36 of the press. They are driven one way or the other by mechanism presently to be described. This revolution of the supports around the shaft of the press gives a revolving motion to the carrier-arms and brings the gripper ends of the arms into radial line with the shafts of any of the printing-cylinders in the press that it may be desired to remove or into a radial line with any position where it is desired to insert the printing-cylinder, tube, or support. The means shown in the drawings for giving this revolving motion to the supports, and hence to the arms, is as follows: A worm 37 on each side of the machine meshes with each worm-wheel 32, as shown in Fig. 4. These worms are each mounted upon a shaft 38, which carries at its other end a beveled gear 39. The beveled gears 39 mesh each with a beveled gear 40 on shaft 41, which runs across the entire press. At the right-hand end of shaft 41, as viewed in Fig. 2, the beveled gear 40 at that end meshes with the beveled gear 42 on the shaft 43. The shaft 43 can be driven from any suitable source of power. I prefer to drive it from a controlling-engine such as is shown and described in my application for a patent filed on the 8th day of September, 1898, known as Serial No. 690,480, for controlling-engines for presses, as in such a case the movements of the parts driven by the shaft 43 can be easily and accurately controlled by an operator. Through worm 37 and its driving mechanism and worm-wheel 32 sleeves 31 and supports 28 can be revolved at pleasure in either direction around shaft 36, thus revolving the carrier-arms and bringing them into any radial line desired.

The carrier-arms are moved back and forth longitudinally in supports 28, so as to move the arms radially outward or inward relative to the shaft of the press, by means of the following-described mechanism, as shown in the drawings herein: Loosely mounted upon sleeve 31 is a sleeve 44, adapted to freely rotate around sleeve 31. Sleeve 44 carries a spiral gear-wheel 45 and a worm-wheel 46 secured to it. Sleeve 44 is adapted to rotate freely upon sleeve 31. Worm-wheel 46 is driven by worm 47 on shaft 48. There is a worm 47, mounted on shaft 48, on each side of the press meshing with each worm-wheel 46. At the other end of each shaft 48 is a beveled gear 49. Beveled gears 49 mesh with beveled gears 50, placed at both ends of shaft 51. Shaft 51 is driven by shaft 52 through a beveled gear-wheel 53, which also meshes with one of the beveled gear-wheels 50. Shaft 52

may be driven from any suitable source of power. I prefer to drive it from a controlling-engine in the same manner as shaft 43 is driven and for the same reason. By means of worm 47, driven by the driving mechanism above described, motion is imparted to spiral gear 45 through spur-gear 46 and sleeve 44. As spiral gear 45 rotates it rotates the gear 35, loosely mounted on carrier-arm 20, and through the screw-threads upon the interior face of sleeve 34 and those on carrier-arm 20 the carrier-arm is moved back or forth through sleeve 29 and arm 33 of the support 28, thus moving the carrier-arm outward or inward in a radial direction relative to shaft and press. As the worms 37 on each side of the press are driven by the same shaft 43 from the controlling-engine or other source of power, the same motion, both in direction and amount, is given to both supports and carrier on each side of the press, and as both arms 47 on each side of the press are driven from a common shaft 52 the same motion, both as to direction and amount, will be given to each of the carrier-arms radially through the supports. A uniform motion, both in a revolving direction and in a radial direction, will be imparted to each of the carrier-arms on each side of the press. The arms will therefore move in unison.

By my improved devices the carrier-arms are mounted centrally of the press or substantially so and are adapted to have a revolving motion and a radial motion relative to the press or its shaft, and can thus at will be moved to any desired position in the press either to carry a printing-cylinder, printing-tube, or support therefor to such part of the press to be inserted therein or to carry such printing-cylinder or support from such part of the press to any convenient point of delivery. Any printing-cylinder, tube, or support therefor can be radially secured to and be carried by my said carrier-arms. When such a printing-cylinder or the like is brought to the proper delivery-point, it can be removed from the carrier-arms by hand, if desired, or by any other suitable means. Where the printing-tube or support therefor is a hollow shell or form, as shown in the drawings, it can be removed to a standard 27. This standard has a receiving-arm 54, which can be brought into line with the shaft carrying the printing-cylinder, tube, or support, and the shaft 54 be secured in line with the shaft of the printing-cylinder by any suitable means—such, for instance, as by a pin 55, adapted to slip into a cylindrical opening in the end of the shaft and to secure the two shafts together. After this has been done part 22 of the head of one of the carrier-arms is swung down or the entire head is removed, as above described, whereupon the printing tube or form or support can be slipped off from its shaft onto the receiving-shaft 54, the disks 56 serving to receive and hold the same where the latter is a hollow printing tube or shell. The printing

tube or shell or support can be removed from the receiving-arm in any suitable way. The reverse of the above operation takes place when a printing-tube or support is inserted into the press.

My improved pressure devices for regulating the pressure between the printing-cylinders and the impression-drum in their preferred form, as shown in the drawings herein, consist of the following devices: The bearing for the shaft of each printing-cylinder on each side of the press consists of a plate 57, adapted to fit into similar-shaped openings 58 in the framework of the press and capable of a slight vertical sliding movement in said openings. Each plate 57 has an opening in it, into which a smaller bearing-piece 59 is adapted to fit, piece 59 having a circular opening 60, adapted to receive the end of a shaft of a printing-cylinder. By means of the form of the piece 59 and the opening into which it is inserted in plate 57, and also by means of tightening-screws 61, piece 59 can be securely fastened in position in sliding plate 57. Plate 57 is provided with an opening 62, into which projects an eccentric 63, the shaft 64 of which is held in bearings in brackets 65, secured to the framework of the press. As eccentric 63 is turned in one direction or another sliding plate 57 is moved upward or downward. Motion is imparted to shaft 64 and eccentric 63 by the following means, viz: A rod 66 is keyed to shaft 64 and is connected at its other end to rod 67. The latter is adjustably mounted in a bracket 68 of a wheel 69, the latter being mounted on the shaft 36 of the press. Sets of rods 66 and 67 and bracket 68 are provided for each printing-cylinder of the press, and all of the sets are similarly secured to different parts of wheels 69. It will of course be understood that there is a wheel 69 at each side of the press. A slight rotary motion can be imparted to wheels 69 by the following mechanism: Each wheel 69 is provided with a segment 70 70 of a worm-wheel, which meshes with a worm 71, mounted on a shaft 72. The two shafts 72, one on each side of the press, carry at their other ends a beveled gear-wheel 73. Beveled gears 73 mesh with beveled gears 74 at the opposite ends, respectively, of shaft 75, the latter shaft running across the press. Shaft 75 is driven by means of shaft 76 and a beveled gear 77 at one end of it meshing with one of the beveled gears 74 on shaft 75. Shaft 76 may be driven by any suitable source of power; but I prefer to connect it and drive it from a controlling-engine in the same manner as above referred to in reference to shafts 43 and 52 and for the same reason. As motion is imparted to worms 71 on different sides of the press by means of the single shaft 76 and the intervening connecting mechanism, a uniform rotary motion in one direction or the other is imparted to the two wheels 69 on the different sides of the press, and as these wheels move one way or the other the printing-cylinders throughout

the press are all moved toward or away from the impression-drum by a uniform movement.

In order to allow individual adjustment of each printing-cylinder, should that be necessary, I preferably secure rods 67 to brackets 68 adjustably by means of the following-described devices: The end of each rod 67 is mounted in a block 77, adapted to slide in grooves in the bracket 68. Block 77 can be adjusted one way or the other along the groove by means of set-screws 78 78.

By means of my improved devices for regulating the pressure between the printing-cylinders and the impression-drum very fine and delicate adjustments can be made and the pressure can be uniformly applied and readily controlled.

Motion is imparted to the multicolor-press shown in the drawings through pulley 79 and gear-wheels 80, 81, 82, and 83. Motion is imparted to the ink-frames to swing them backward and forward through shaft 84, driven from any suitable source of power, but preferably from a controlling-engine, through beveled gears 85 86 87, shaft 88, worm 89, and worm-wheel 90, mounted on shaft 91, carrying ink-frames 92 92. The devices for driving the other parts of the press form no part of my present invention, are not shown in detail in the drawings, and will not be further described.

By employing worm-wheels 46 and worms 47 and also worm-wheels 32 and worms 37 the carrier-arms will be locked in any position where they may stop and be prevented both from a revolving motion and a radial motion through the supports until the worms or one set of them are again rotated.

What I claim as new, and desire to secure by Letters Patent, is—

1. In a press, the combination of carrier-arms mounted centrally of the press and adapted to have a radial and also a revolving movement and adapted to carry printing-cylinders, tubes or supports therefor and means for imparting radial and revolving movements to the carrier-arms, whereby printing-cylinders, tubes or supports therefor can be removed from their proper places in the press and be carried to a convenient place of delivery or can be carried from such place to and be inserted in, their proper places in the press.

2. In a press, the combination of carrier-arms mounted centrally of the press and adapted to have a radial and also a revolving movement and adapted to carry printing-cylinders, tubes or supports therefor, and means, driven by the driving mechanism of the press, for imparting radial and revolving movements to the carrier-arms, whereby printing-cylinders, tubes or supports therefor can be removed from their proper places in the press and be carried to a convenient place of delivery or can be carried from such place to and be inserted in, their proper places in the press.

3. In a press, the combination of carrier-arms mounted centrally of the press and adapted to have a radial and also a revolving movement and adapted to carry printing-cylinders, tubes or supports therefor, and means, driven by the driving mechanism of the press and connected with a controlling-engine, for imparting radial and revolving movements to the carrier-arms, whereby printing-cylinders, tubes or supports therefor can be removed from their proper places in the press and be carried to a convenient place of delivery or can be carried from such place to and be inserted in, their proper places in the press.

4. In a press, the combination of supports for the carrier-arms mounted centrally of the press and adapted to have a revolving movement, carrier-arms, adapted to carry printing-cylinders, tubes or supports therefor and mounted on the supports and adapted to have radial movement relative thereto, and means for imparting revolving movement to the supports and means for imparting radial movement to the carrier-arms, whereby printing-cylinders, tubes or supports therefor can be removed from their proper places in the press and be carried to a convenient place of delivery or can be carried from such place to and be inserted in, their proper places in the press.

5. In a press, the combination of supports for the carrier-arms mounted centrally of the press and adapted to have a revolving movement, carrier-arms, adapted to carry printing-cylinders, tubes or supports therefor and mounted on the supports and adapted to have radial movement relative thereto, and means for imparting revolving movement to the supports and means for imparting radial movement to the carrier-arms driven through a controlling-engine, whereby printing-cylinders, tubes or supports therefor can be removed from their proper places in the press and be carried to a convenient place of delivery or can be carried from such place to and be inserted in, their proper places in the press.

6. In a press, the combination of supports for the carrier-arms mounted upon the main shaft of the press and adapted to revolve around said shaft, carrier-arms, adapted to carry printing-cylinders, tubes or supports therefor and mounted in the supports and adapted to move through the supports radially of the press, means for imparting to the supports a revolving movement around the shaft and means for moving the carrier-arms through the supports in a radial direction, whereby printing-cylinders, tubes or supports therefor can be removed from their proper places in the press and be carried to a convenient place for delivery or can be carried from such place to and be inserted in, their proper places in the press.

7. In a press, the combination of supports for the carrier-arms mounted upon the main shaft of the press and adapted to revolve around said shaft, means for revolving said

supports, carrier-arms, adapted to carry printing-cylinders, tubes or supports therefor and mounted in the supports and adapted to move through the supports radially of the press, gear-wheels screw-threaded interiorly, loosely mounted upon the carrier-arms and restrained by stops upon the supports from radial motion relative to the supports, screw-threads upon the carrier-arms adapted to engage with the interior screw-threads of said gear-wheels, and gearing meshing with said gear-wheel for rotating the latter, whereby movement will be imparted to the carrier-arms through the supports in a radial direction and whereby printing-cylinders, tubes or supports therefor can be removed from their proper places in the press and be carried to a convenient place of delivery or can be carried from such place to and be inserted in, their proper places in the press.

8. In a press, the combination of supports for the carrier-arms mounted upon the main shaft of the press and adapted to revolve around said shaft, a worm-wheel secured to said supports, a worm meshing with said worm-wheel and means for turning the worm, under the control of the operator, whereby the supports may be revolved around the shaft at will and will be locked in any position where they may stop, carrier-arms, adapted to carry printing-cylinders, tubes or supports therefor and mounted in the supports and adapted to move through the supports radially of the press, gear-wheels screw-threaded interiorly, loosely mounted upon the carrier-arms and restrained by stops upon the supports from radial motion relative to the supports, screw-threads upon the carrier-arms adapted to engage with the interior screw-threads of said gear-wheels, a spiral gear-wheel meshing with each of said gear-wheels, a worm-wheel secured to each spiral gear-wheel, a worm meshing with each worm-wheel and means for turning the worms, under the control of the operator, whereby movement will be imparted to the carrier-arms through the supports in a radial direction at will and the carrier-arms will be locked in any position where they may stop, and whereby printing-cylinders, tubes or supports therefor can be removed from their proper places in the press and be carried to a convenient place of delivery or can be carried from such place to and be inserted in, their proper places in the press.

9. In a press, carrier-arms for moving printing-cylinders, tubes or supports therefor, each provided with a removable head having devices for holding and clamping one end of the shafts of the printing-cylinders, tubes or supports, and means for securing the removable head to the carrier-arm and for detaching it therefrom.

10. In a press, carrier-arms for moving printing-cylinders, tubes or supports therefor, each provided with a removable head having devices for holding and clamping one end of the shafts of the printing-cylinders, tubes

or supports, a rod adapted to fit into and move in a cylindrical recess in the carrier-arm, means for locking the rod in any position and means for securing the removable head to the rod, whereby the rod and removable head may be unlocked and be removed out of the way of printing-cylinders, tubes or supports therefor while being placed upon or removed from the carrier-arms.

10 11. In a press, the combination of a series of printing-cylinders, adjustable plates carrying the bearings of each cylinder, eccentrics mounted upon the framework of the press adapted to engage with the adjustable  
15 plates to move them radially outward or inward, rods secured to the shafts of the eccentrics for turning the latter, a wheel at each side of the press to which the said rods on that side of the press are secured, and means  
20 for rocking said wheels driven from a common source of power, whereby the printing-cylinders may all be moved the same distance and in unison toward or away from the impression-drum and the pressure between the  
25 printing-cylinder and the drum be regulated.

12. In a press, the combination of a series of printing-cylinders, adjustable plates carrying the bearings of each cylinder, eccentrics mounted upon the framework of the  
30 press adapted to engage with the adjustable plates to move them radially outward or inward, rods secured to the shafts of the eccentrics for turning the latter, a wheel at each side of the press to which the said rods on  
35 that side of the press are adjustably secured, means for adjusting the locking connections between each rod and its wheel, whereby the

pressure between each printing-cylinder and the drum can be separately regulated, and means for rocking said wheels driven from a  
40 common source of power, whereby the printing-cylinders may all be moved the same distance and in unison toward or away from the impression-drum and the pressure between the printing-cylinder and the drum be regu- 45  
lated.

13. In a press, the combination of a series of printing-cylinders, adjustable plates carrying the bearings of each cylinder, eccentrics mounted upon the framework of the  
50 press adapted to engage with the adjustable plates to move them radially outward or inward, rods secured to the shafts of the eccentrics for turning the latter, a wheel at each  
55 side of the press to which the said rods on that side of the press are adjustably secured, set-screws for adjusting the locking connections between each rod and its wheel, whereby the pressure between each printing-cylinder  
60 and the drum can be separately regulated, and means for rocking said wheels driven from a common source of power, whereby the printing-cylinders may all be moved the same distance and in unison toward or away from  
65 the impression-drum and the pressure between the printing-cylinder and the drum be regulated.

In testimony whereof I have signed my name to this specification in the presence of two subscribing witnesses.

EDWARD HETT.

Witnesses:

EDWIN SEGER,

GEO. W. MILLS, Jr.