

(No Model.)

J. HEIM.

MACHINE FOR SPREADING LIQUIDS OVER SHEETS OF PAPER, &c.

No. 577,683.

Patented Feb. 23, 1897.

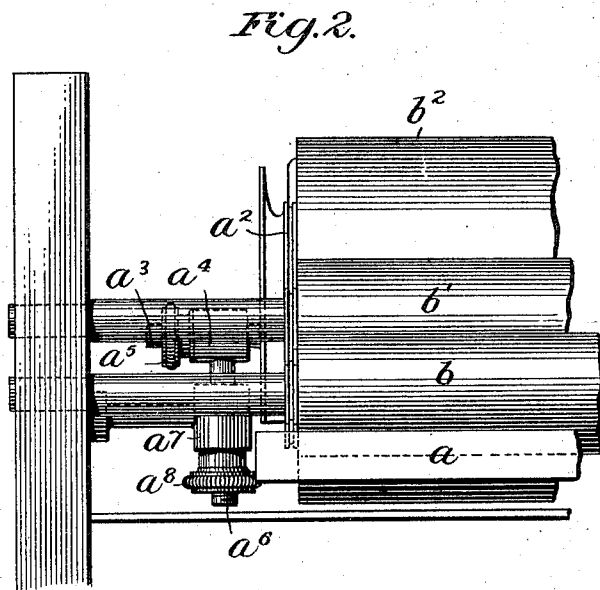
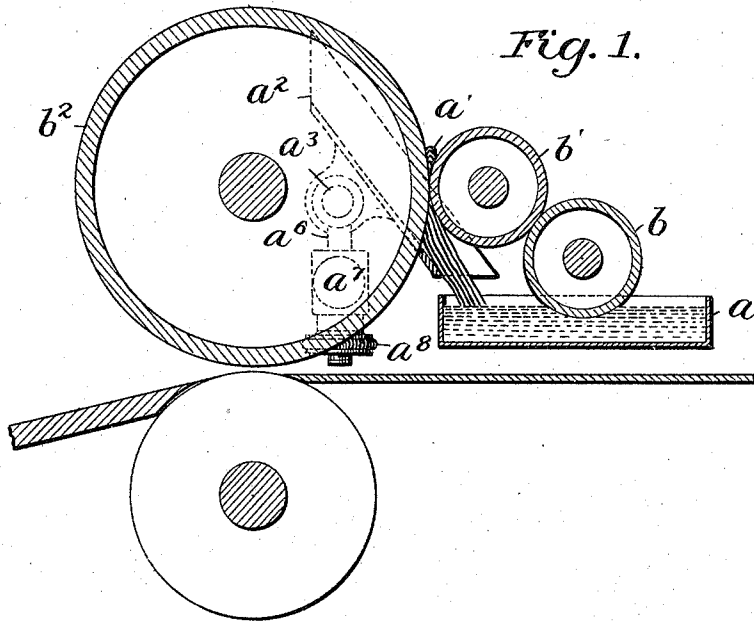

Witnesses
J. Hinkel
E. Howard Ellis

Inventor
Josef Heim
by *Inter Ocean*
Attorneys

UNITED STATES PATENT OFFICE.

JOSEF HEIM, OF OFFENBACH-ON-THE-MAIN, GERMANY.

MACHINE FOR SPREADING LIQUIDS OVER SHEETS OF PAPER, &c.

SPECIFICATION forming part of Letters Patent No. 577,683, dated February 23, 1897.

Application filed November 5, 1896. Serial No. 611,165. (No model.) Patented in England July 18, 1895, No. 13,772.

To all whom it may concern:

Be it known that I, JOSEF HEIM, a subject of the Emperor of Germany, and a resident of Offenbach-on-the-Main, Germany, have invented certain new and useful Improvements in Machines for Spreading Liquids Over Sheets of Paper or the Like, (for which I have obtained Letters Patent of Great Britain, No. 13,772, dated July 18, 1895,) of which the following is a specification.

This invention relates to machinery for spreading liquid or semiliquid substances over paper, cardboard, fabric, sheet metal, glass, or other surfaces, and more especially to that class of machines in which the substance to be applied is spread over the surface which it is desired to cover or impregnate with it by means of rollers.

A simple method of constructing a machine of this description consists in so arranging the spreading-roller that it rotates in the receptacle containing the substance to be applied in direct contact therewith, and that the article which is to receive the coating is afterward caused to travel over such roller. In such an arrangement, however, it is necessary to insert the printed sheets or other articles to be coated with the printed surface downward, and consequently the removal of the coated articles while in a moist condition cannot be effected by means of, say, a collecting-table or any other of the usual stripping devices, such as bands or the like, lest they should be damaged. All that can be done under the circumstances is to remove the articles by hand, and even then the danger of spoiling the machinery is not altogether obviated. Besides it is in such case impossible to ascertain whether as an article passes through the machine the substance employed to form the coating is being spread thereon in a uniform and proper manner or not; and, lastly, the printed articles to be inserted with the front side downward if placed on a table or platform prior to being taken up by the machine are apt to be marked with scratches or otherwise damaged through contact with the table unless the insertion of the articles be also effected by hand.

Now the object of this invention is to provide an improved machine for the purpose stated which is capable of spreading the li-

quid in the downward direction, so that the sheets or other articles to be covered or coated before their introduction into the machine may be placed on the feeding-table with their backs downward and after passing through the machine in the same position be delivered onto a table band or apron or the like without any danger of damaging the coated surface.

Where the liquid is spread downwardly, it is of course impossible to allow the spreading-roller to revolve in direct contact with the liquid in the reservoir, and it is necessary that it should be fed with such liquid from the reservoir through the intermediate agency of auxiliary rollers. Inasmuch, however, as the spreading-roller, in order to be capable of uniformly distributing the liquid over the surface to be covered or impregnated, must possess a very considerable diameter, the liquid transmitted from the auxiliary or feeding rollers onto the main or spreading roller is liable in course of time to harden upon the wide surface of the latter and form a crust, which is apt to interfere with or render altogether impossible the desired uniformity of the coating. This danger is obviated in the improved machine forming the subject of the present invention by so arranging the feeding-rollers that they supply the spreading-roller with a quantity of liquid considerably in excess of that which is required for covering the articles, so that the surplus constantly keeps the material adhering to the spreading-roller in a liquid condition and prevents any solid crust from forming thereon. In order to avoid the inconvenience which would on the other hand result from the surplus liquid running down the side of the spreading-roller as soon as delivered onto it, whereby it would not only fail to attain the object just stated, but also smear or stain the surface to be covered, guard-plates are arranged on either side of the spreading-roller, which plates by bearing upon each end of the said roller form in conjunction with this and the adjoining feeding-roller a receptacle for the liquid to collect up to a certain level. On the side next to the roller the grooves or channels formed by the plates conduct the liquid overflowing the upper edges of the plates back to the reservoir. Owing to this arrangement liquid is kept in

constant circulation from the supply-reservoir to the spreading-roller, then from this roller into the receptacles formed by the rollers and the side plates, and back again to the main reservoir, which effectually prevents any of the liquid from solidifying on the spreading-roller. By adjusting the plates higher or lower, as required, the depth or level of the liquid layer on the spreading-roller can be controlled.

In order that the invention may well be understood, I will describe, with reference to the accompanying drawings, an arrangement accordingly thereto, but I do not limit myself to the precise details shown.

Figure 1 is a transverse sectional elevation, and Fig. 2 is a one-half front elevation, of so much of a machine as is necessary to illustrate my invention.

The liquid or semiliquid substance used is fed to the spreading-roller b^2 in large quantities from the reservoir a by means of feeding and distributing rollers b b' , and any surplus of the liquid or semiliquid collects between the spreading-roller b^2 and the roller b' , as shown at a' in Fig. 1. To retain this superfluous liquid or semiliquid a' and prevent it from flowing off the sides of the roller b^2 , plates a^2 are arranged on both ends of the said roller b^2 , the said plates a^2 closing in laterally the space between the two rollers b' b^2 . These plates a^2 have each an outwardly-extending groove or channel through which the superfluous liquid or semiliquid substance which rises above the upper edge of the plates a^2 flows back into the main reservoir a . The quantity of the liquid or semiliquid substance which will collect at a' will be in accordance with the position of the plates a^2 , that is, whether they are raised or lowered. In order to enable the height or level of the said plates a^2 to be adjusted and their bearing against the ends of the rollers b' b^2 to be regulated, or to enable them to be moved away from such rollers for cleaning or other purposes, each plate is mounted upon a bar or rod a^3 , adjustable horizontally within a sleeve a^4 . This adjustment is effected by means of a screw-nut

a^5 , working upon a screw-thread on the end of the said bar or rod a^3 , the said sleeve a^4 being carried by a rod a^6 , mounted in a guiding-sleeve a^7 , and being screw-threaded and capable of being moved either up or down in the sleeve a^7 by means of a nut a^8 , working on its screwed end.

It is to be understood that the same arrangement is repeated at the other side of the machine.

When the liquid is to be spread over both sides of a sheet or article, there may be provided an additional spreading-roller underneath, which may either rotate within the liquid-supply reservoir direct or be arranged similarly to the upper spreading-roller.

I claim—

1. In a machine for spreading liquid or semiliquid substances upon the surfaces of materials of different kinds, the combination with a liquid-reservoir, a spreading-roller, and a roller distributing the liquid to said spreading-roller, of slanting or inclined guard-plates extending across the ends of the rollers intermediate the axes thereof, and having channels or grooves for conveying the surplus liquid back to the reservoir, substantially as described.

2. In a machine for spreading liquid or semiliquid substances over the surfaces of materials of different kinds, the combination with a liquid-reservoir, a spreading-roller, and a roller distributing the liquid to said spreading-roller, of slanting or inclined guard-plates extending across the ends of the rollers intermediate the axes thereof, and having conducting channels or grooves leading to the reservoir, means for adjusting the plates horizontally, and means for adjusting the same vertically, substantially as described.

In testimony whereof I have signed my name to this specification in the presence of two subscribing witnesses.

JOSEF HEIM.

Witnesses:

FRANZ HASSLACHER,
MICHAEL VOLK.