

**(12) STANDARD PATENT**  
**(19) AUSTRALIAN PATENT OFFICE**

(11) Application No. **AU 2019271283 B2**

(54) Title  
**Systems, devices, and methods for the accurate deployment and imaging of an implant in the prostatic urethra**

(51) International Patent Classification(s)  
**A61F 2/04** (2013.01)                      **A61F 2/88** (2006.01)  
**A61F 2/02** (2006.01)                      **A61F 2/962** (2013.01)  
**A61F 2/844** (2013.01)                      **A61F 2/966** (2013.01)  
**A61F 2/86** (2013.01)

(21) Application No: **2019271283**                      (22) Date of Filing: **2019.05.16**

(87) WIPO No: **WO19/222481**

(30) Priority Data

| (31) Number       | (32) Date         | (33) Country |
|-------------------|-------------------|--------------|
| <b>62/673,097</b> | <b>2018.05.17</b> | <b>US</b>    |

(43) Publication Date: **2019.11.21**

(44) Accepted Journal Date: **2025.02.13**

(71) Applicant(s)  
**Zenflow, Inc.**

(72) Inventor(s)  
**BLY, Austin Michael;SICOTTE, Marcel Song;MEHTA, Shreya;BELEF, William Martin;DAMIANO, Nicholas**

(74) Agent / Attorney  
**AJ PARK, PO Box 949, Wellington, 6140, NZ**

(56) Related Art  
**US 5282472 A**  
**US 2015/0257908 A1**  
**US 2011/0077676 A1**  
**US 2002/0151967 A1**



(51) International Patent Classification:

A61F 2/04 (2013.01) A61F 2/88 (2006.01)  
A61F 2/02 (2006.01) A61F 2/962 (2013.01)  
A61F 2/844 (2013.01) A61F 2/966 (2013.01)  
A61F 2/86 (2013.01)

(21) International Application Number:

PCT/US2019/032637

(22) International Filing Date:

16 May 2019 (16.05.2019)

(25) Filing Language:

English

(26) Publication Language:

English

(30) Priority Data:

62/673,097 17 May 2018 (17.05.2018) US

(71) Applicant: **ZENFLOW, INC.** [US/US]; 395 Oyster Point Boulevard, Suite 501, San Francisco, California 94080 (US).

(72) Inventors: **BLY, Austin Michael**; 31 Via Buen Corazon, San Clemente, California 92673 (US). **SICOTTE, Marcel Song**; 1001 Pine Street, #802, San Francisco, California 94109 (US). **MEHTA, Shreya**; 628 Capp Street, San Francisco, California 94110 (US). **BELEF, William Martin**; 395 Oyster Point Boulevard, Suite 501, San Francisco, Cal-

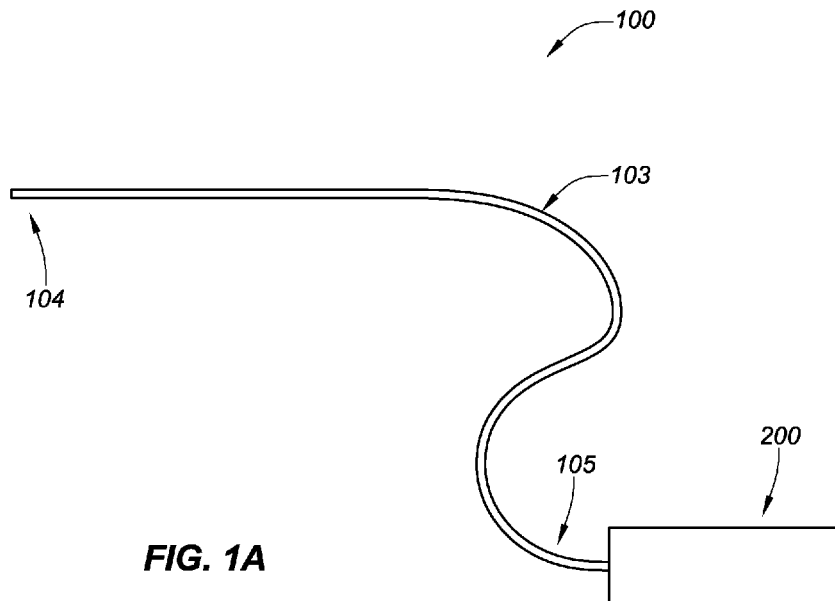
ifornia 94080 (US). **DAMIANO, Nicholas**; 177 Day Street, San Francisco, California 94131 (US).

(74) Agent: **MARK STIRRAT**; ONE LLP, 4000 Macarthur Blvd., East Tower, Suite 500, Newport Beach, California 92660 (US).

(81) Designated States (unless otherwise indicated, for every kind of national protection available): AE, AG, AL, AM, AO, AT, AU, AZ, BA, BB, BG, BH, BN, BR, BW, BY, BZ, CA, CH, CL, CN, CO, CR, CU, CZ, DE, DJ, DK, DM, DO, DZ, EC, EE, EG, ES, FI, GB, GD, GE, GH, GM, GT, HN, HR, HU, ID, IL, IN, IR, IS, JO, JP, KE, KG, KH, KN, KP, KR, KW, KZ, LA, LC, LK, LR, LS, LU, LY, MA, MD, ME, MG, MK, MN, MW, MX, MY, MZ, NA, NG, NI, NO, NZ, OM, PA, PE, PG, PH, PL, PT, QA, RO, RS, RU, RW, SA, SC, SD, SE, SG, SK, SL, SM, ST, SV, SY, TH, TJ, TM, TN, TR, TT, TZ, UA, UG, US, UZ, VC, VN, ZA, ZM, ZW.

(84) Designated States (unless otherwise indicated, for every kind of regional protection available): ARIPO (BW, GH, GM, KE, LR, LS, MW, MZ, NA, RW, SD, SL, ST, SZ, TZ, UG, ZM, ZW), Eurasian (AM, AZ, BY, KG, KZ, RU, TJ, TM), European (AL, AT, BE, BG, CH, CY, CZ, DE, DK, EE, ES, FI, FR, GB, GR, HR, HU, IE, IS, IT, LT, LU, LV, MC, MK, MT, NL, NO, PL, PT, RO, RS, SE, SI, SK, SM,

(54) Title: SYSTEMS, DEVICES, AND METHODS FOR THE ACCURATE DEPLOYMENT AND IMAGING OF AN IMPLANT IN THE PROSTATIC URETHRA



**FIG. 1A**

(57) Abstract: Systems, devices, and methods are provided for the delivery of an implant into the prostatic urethra. Embodiments of delivery systems can include a delivery device for insertion into the patient and a proximal control device for use in controlling release of the implant from the delivery device.



TR), OAPI (BF, BJ, CF, CG, CI, CM, GA, GN, GQ, GW,  
KM, ML, MR, NE, SN, TD, TG).

**Published:**

— *with international search report (Art. 21(3))*

**SYSTEMS, DEVICES, AND METHODS FOR THE ACCURATE DEPLOYMENT AND  
IMAGING OF AN IMPLANT IN THE PROSTATIC URETHRA**

FIELD

[0001] The subject matter described herein relates to systems, devices, and methods for delivery or deployment of an implant into the prostatic urethra, more specifically, delivery in an atraumatic and minimally-invasive manner through the tortuous bends of the male urethra.

BACKGROUND

[0002] There are numerous clinical reasons for placement of an implant into the prostatic urethra, such as for treatment of urinary retention associated with benign prostatic hyperplasia (BPH), blockages from prostate cancer, bladder cancer, urinary tract injury, prostatitis, bladder sphincter dyssynergia, benign or malignant urethral stricture, and other conditions for which treatment is desired. Due to the naturally complex and tortuous anatomical geometry, patient-to-patient geometric and tissue variability, and anatomical restrictions associated with those conditions, accurate and consistent placement of an implant into the prostatic urethral lumen has proven challenging. Furthermore, complex challenges are presented in the design and/or fabrication of systems with sufficient flexibility to deliver such an implant in a minimally-invasive manner. For these and other reasons, needs exist for improved systems, devices, and methods of implant delivery to the prostatic urethra.

SUMMARY

[0003] In accordance with a first aspect of the invention, there is provided a system for delivering an implant, the system comprising a delivery device comprising: an outer tubular member comprising an imaging device located in a distal end region of the outer tubular member; an inner tubular member being within a lumen of the outer tubular member, wherein the inner tubular member is adapted to house at least a portion of an implant, wherein the inner tubular member is configured to slide distally and proximally within the lumen of the outer tubular member; one or more structures slidably advanceable within the inner tubular member to cause deployment of the implant from within the inner tubular member; and a proximal control device coupled with the inner tubular member and the one or more structures, and releasably coupled with the outer tubular member with a coupling mechanism, wherein the proximal control

2019271283 23 Jan 2025

device is configured to longitudinally move the inner tubular member and the outer tubular member concurrently.

[0004] In accordance with a second aspect of the invention, there is provided a method of imaging delivery of an implant, the method comprising: advancing a delivery device within a urethra of a patient, wherein the delivery device comprises an outer tubular member comprising an imaging device located in a distal end region of the outer tubular member, an inner tubular member within a lumen of the outer tubular member and housing at least a portion of an implant, wherein the inner tubular member is configured to slide distally and proximally within the lumen of the outer tubular member, and one or more structures slidably advanceable within the inner tubular member to cause deployment of the implant from within the inner tubular member, wherein the outer tubular member, inner tubular member, and one or more structures are each coupled with a proximal control device outside of the patient; longitudinally retracting the inner tubular member with respect to the proximal control device and the one or more structures to at least partially deploy the implant from the inner tubular member; and while the inner tubular member is being longitudinally retracted, concurrently (a) longitudinally retracting the outer tubular member with respect to the proximal control device and (b) imaging the at least partially deployed implant with an imaging device located at a distal end region of the outer tubular member.

[0005] In accordance with a third aspect of the invention, there is provided a method of user assembly of a proximal control device, comprising: inserting an inner tubular member into a lumen of an outer tubular member, wherein the inner tubular member is configured to slide distally and proximally within the lumen of the outer tubular member, wherein the inner tubular member is coupled with a first portion of a proximal control device and the outer tubular member is coupled with a second portion of the proximal control device; and coupling the first portion of the proximal control device to the second portion of the proximal control device with a coupling mechanism, wherein the inner tubular member is longitudinally and rotationally movable with respect to the first portion of the proximal control device, wherein the first portion is coupled to the second portion such that longitudinal movement of the inner tubular member causes longitudinal movement of the second portion and outer tubular member, and wherein the first portion is coupled to the second portion such that rotational movement of the inner tubular member does not cause rotational movement of the second portion and outer tubular member.

2019271283 23 Jan 2025

[0006] Provided herein are a number of example embodiments of delivery systems for delivering or deploying implants within the prosthetic urethra or other parts of the body, and methods related thereto. Embodiments of the delivery system can include a delivery device insertable into the prosthetic urethra and a proximal control device coupled with the delivery device and configured to control deployment of one or more implants from the delivery device. In some embodiments, the delivery device can include multiple tubular components each having various functions described in more detail herein. Embodiments of the delivery system have imaging capabilities. Multiple embodiments of implants for use with the delivery systems are also described, as are various implanted placements of those implants.

[0007] Other systems, devices, methods, features and advantages of the subject matter described herein will be or will become apparent to one with skill in the art upon examination of the following figures and detailed description. It is intended that all such additional systems, methods, features and advantages be included within this description, be within the scope of the subject matter described herein, and be protected by the accompanying claims. In no way should the features of the example embodiments be construed as limiting the appended claims, absent express recitation of those features in the claims.

[0008] Reference may be made in the description to subject matter which is not in the scope of the appended claims. That subject matter should be readily identifiable by a person skilled in the art and may assist putting into practice the invention as defined in the appended claims.

#### BRIEF DESCRIPTION OF THE FIGURES

[0009] The details of the subject matter set forth herein, both as to its structure and operation, may be apparent by study of the accompanying figures, in which like reference numerals refer to like parts. The components in the figures are not necessarily to scale, emphasis instead being placed upon illustrating the principles of the subject matter. Moreover, all illustrations are intended to convey concepts, where relative sizes, shapes and other detailed attributes may be illustrated schematically rather than literally or precisely.

[0010] FIG. 1A is a block diagram depicting an example embodiment of a delivery system.

[0011] FIGs. 1B, 1C, and 1D are side, end, and perspective views, respectively, depicting an example embodiment of an implant.

2019271283 23 Jan 2025

[0012] FIGs. 2A-2H are perspective views depicting example embodiments of a delivery system in different stages of deployment of an implant.

[0013] FIGs. 3A-3C are perspective views depicting example embodiments of a grasper component in use within a delivery system.

[0014] FIGs. 4A-4J are partial cross-sectional views depicting example embodiments of anchor delivery members of a delivery system.

[0015] FIGs. 5A-5B are side views depicting an example embodiment of a delivery system in various stages of deployment of an implant.

[0016] FIGs. 6A and 6B are interior side and interior perspective views, respectively, depicting an example embodiment of a proximal control device.

[0017] FIG. 6C is a perspective view depicting an example embodiment of a gear for use with the delivery system.

[0018] FIG. 7A is an interior top down view depicting an example embodiment of components of a proximal control device.

[0019] FIG. 7B is a perspective view depicting an example embodiment of a cam.

[0020] FIG. 8 is an interior side view depicting an example embodiment of a gear assembly.

[0021] FIGs. 9A-9F are interior perspective views depicting an example embodiment of components of a proximal control device.

[0022] FIG. 10A is a flowchart depicting an example embodiment of a method for delivering an implant.

[0023] FIG. 10B is a timing diagram depicting an example embodiment of a sequence of steps for deploying an implant.

[0024] FIGs. 11A-12C are perspective views depicting example embodiments of components within a proximal control device.

[0025] FIGs. 12D-12E are perspective views depicting an example embodiment of a distal end region of an outer tubular member.

[0026] FIG. 13 as an example cross-section of the male anatomy.

[0027] FIG. 14A is an example cross-section of the male anatomy having an example embodiment of an implant deployed therein.

[0028] FIG. 14B is an example cross-section of the male anatomy and FIG. 14C is an example cross-section of the male anatomy taken along line 14C-14C of FIG. 14B.

2019271283 23 Jan 2025

[0029] FIG. 14D is an example cross-section of the male anatomy having an example embodiment of an implant deployed therein and FIG. 14E is an example cross-section of the male anatomy taken along line 14E-14E of FIG. 14D.

[0030] FIG. 14F is an example cross-section of the male anatomy having an example embodiment of an implant deployed therein and FIG. 14G is an example cross-section of the male anatomy taken along line 14F-14F of FIG. 14G.

#### DETAILED DESCRIPTION

[0031] Before the present subject matter is described in detail, it is to be understood that this disclosure is not limited to the particular embodiments described, as such may, of course, vary. It is also to be understood that the terminology used herein is for the purpose of describing particular embodiments only, and is not intended to be limiting, since the scope of the present disclosure will be limited only by the appended claims.

[0032] The subject matter presented herein is described in the context of delivery or deployment of one or more implants within the prostatic urethra. The purpose for deployment of the implant(s) in the prostatic urethra can vary. The embodiments described herein are particularly suited for treatment of BPH, but they are not limited to such. Other conditions for which these embodiments can be used include, but are not limited to, treatment of blockages from prostate cancer, bladder cancer, urinary tract injury, prostatitis, bladder sphincter dyssynergia, and/or benign or malignant urethral stricture. Further, these embodiments can have applicability for deployment of one or more implants in other locations of the urinary tract or in the bladder, as well as other biological lumens, cavities, or spaces, such as the human vasculature, cardiac system, pulmonary system, or gastro-intestinal tract, including locations within the heart, stomach, intestines, liver, spleen, pancreas, and kidney.

[0033] FIG. 1A is a block diagram depicting an example embodiment of delivery system 100 having an elongate delivery device 103 coupled with a proximal control device 200. A distal end region 104 is adapted to be inserted into the patient's urethra (or other lumen or body cavity of the patient) through the urethral orifice. Distal end region 104 preferably has an atraumatic configuration (e.g., relatively soft and rounded) to minimize irritation or trauma to the patient. Elongate delivery device 103 carries or houses one or more implants 102 (not shown) to be delivered or deployed within or adjacent to the prostatic urethra. A proximal end region 105 of

2019271283 23 Jan 2025

delivery device 103 is coupled with proximal control device 200, which remains outside of the patient's body and is configured to be used by the physician or other healthcare professional to control the delivery of one or more implants 102.

Example Embodiments of Delivery Devices and Related Methods

[0034] FIGs. 1B, 1C, and 1D are side, end, and perspective views, respectively, depicting an example embodiment of implant 102 in an at-rest configuration. Implantable device 102 is biased towards the at-rest configuration depicted here and is deformable between the at-rest configuration and a relatively more elongate housed (or delivery) configuration (e.g., see FIG. 3A) for housing implant 102 within delivery device 103. The housed configuration can be a straight or lineated state with minimal curvature. The at-rest configuration has a relatively greater lateral width, and a relatively shorter longitudinal length than the housed configuration. Upon exiting an open end of delivery device 103, implant 102 is free to transition its shape back towards that of the at-rest configuration although restraints imparted by the patient's urethral wall may prevent implant 102 from fully reaching the at-rest configuration. Because implant 102 is biased towards the at-rest configuration, implant 102 is configured to automatically expand when freed from the restraint of delivery device 103, and can be referred to as "self-expanding." The shape of implant 102 in its deployed state within, e.g., the patient's urethra, can be referred to as the deployed configuration, and will often be a shape that is deformed from the at-rest configuration by the surrounding tissue, although the deployed configuration can be the same as the at-rest configuration.

[0035] Implant 102 can be configured in numerous different ways, including any and all of those implant configurations described in U.S. Patent Publ. No. 20150257908 and/or Int'l Publ. No. WO 2017/184887, both of which are incorporated by reference herein for all purposes.

[0036] Implant 102 can be formed from one or more discrete bodies (e.g., wires, ribbons, tubular members) of varying geometries. Referring to the embodiment of FIGs. 1B-1D, implant 102 has a main body formed of only one single wire member set in a predetermined shape. Implant 102 can have two or more ring-shaped structures 111 (in this embodiment there are four: 111a, 111b, 111c, and 111d) with one or more interconnections 112 extending between each pair of adjacent ring-shaped structures 111 (in this embodiment there is one interconnection between each adjacent pair, for a total of three: 112a, 112b, and 112c). Each interconnection 112 extends from

2019271283 23 Jan 2025

one ring-shaped structure 111 to an immediately adjacent ring-shaped structure 111. Each interconnection 112 can have a relatively straight shape (not shown) or a curved (e.g., semi-circular or semi-elliptical) shape as shown in FIGs. 1B-1D.

[0037] Ring-shaped structures 111 are configured to maintain the urethra in a fully or partially open state when expanded from the housed configuration. Device 100 can be manufactured in various sizes as desired, such that the width (e.g., diameter) of each ring-shaped structure 111 is slightly larger than the width of the urethra, and the length of each interconnection 112 determines the spacing between ring-shaped structures 111. Ring-shaped structures 111 can have the same or different widths. For example, in the embodiment depicted here, ring-shaped structure 111a has a relatively smaller width than structures 111b-111d, which have the same width. This can accommodate prostatic urethras that converge to a smaller geometry before the bladder neck.

[0038] Each ring-shaped structure 111 can be located or lie in a single plane, and in some embodiments that single plane can be oriented with a normal axis perpendicular to a central axis 124 of implant 102 (as depicted in FIG. 1B). In other embodiments, ring-shaped structures 111 can be located in multiple planes. Ring-shaped structures 111 can extend around central axis 126 to form a complete circle (e.g., a 360 degree revolution) or can form less than a complete circle (e.g., less than 360 degrees) as shown here. Although not limited to such, in many embodiments ring-shaped structures 111 extend between 270 and 360 degrees.

[0039] As can be seen from FIGs. 1B-1D, the geometry of implant 102 can have a cylindrical or substantially cylindrical outline shape with a circular or elliptical cross-section. In other embodiments, implant 102 can have a prismatic or substantially prismatic shape with triangular or substantially triangular cross-section, or otherwise.

[0040] Implant 102 can also include a distal engagement member 114 and a proximal engagement member 115 that are each configured to engage with elements of delivery device 103. Engagement with delivery device 103 can serve one or more purposes such as allowing control of the release of implant 102, allowing movement of the ends of implant 102 relative to each other, and/or allowing retrieval of implant 102 after deployment, e.g., in an instance where the physician desires to recapture implant 102 and redeploy implant 102 in a different position. In this embodiment, distal engagement member 114 is a wire-like extension from ring-shaped structure 111a that has a curved (e.g., S-like) shape for positioning an atraumatic end 116 (e.g.,

2019271283 23 Jan 2025

rounded, spherical, ballized) in a location suitable for engagement with delivery device 103 and thereby allow control of the distal end region of implant 102. Likewise, proximal engagement member 115 has a curved shape for positioning another atraumatic end 117 in a location suitable for engagement with delivery device 103 and thereby allow control of the proximal end region of implant 102. In other embodiments, distal engagement member 114 and proximal engagement member 115 can be omitted, and delivery device 103 can couple with implant 102 at one or more other distal and/or proximal locations, such as on a ring-shaped structure 111 or interconnect 112.

[0041] Delivery device 103 can include one or more elongate flexible members (e.g., 120, 130, 140, and 150 as described below), each having one or more inner lumens. One or more elongate flexible members of delivery device 103 can be a solid or a non-hollow member with no inner lumen. FIG. 2A is a perspective view depicting an example embodiment of distal end region 104 of a delivery device 103. In this embodiment, delivery device 103 includes a first elongate tubular member 120, a second elongate tubular member 130, a third elongate tubular member 140, and a fourth elongate tubular member 150. Delivery device 103 can vary and in other embodiments can include more or less tubular members.

[0042] In this embodiment, first elongate tubular member 120 is the outermost tubular member and is flexible yet provides support for members contained therein. First tubular member 120 is referred to herein as outer shaft 120 and can have one or more inner lumens. In this embodiment, outer shaft 120 includes a first inner lumen 121 housing second elongate tubular member 130, which is referred to herein as inner shaft 130. Outer shaft 120 and inner shaft 130 are each controllable independent of the other. Inner shaft 130 can slide distally and proximally within lumen 121 and is shown here partially extending from an open distal terminus of outer shaft 120.

[0043] In this embodiment, outer shaft 120 includes three additional lumens 122, 123, and 124. An illumination device (not shown) and an imaging device (not shown) can be housed in two of lumens 122-124 (e.g., lumens 122 and 123). The imaging device can utilize any desired type of imaging modality, such as optical or ultrasound imaging. In one example embodiment the imaging device utilizes a forward (distal) looking CMOS imager. The illumination device can be configured to provide adequate illumination for optical imaging, and in one embodiment includes one or more light emitting diodes (LEDs). In embodiments where illumination is not

2019271283 23 Jan 2025

required, such as for ultrasound imaging, the illumination device and its respective lumen can be omitted. The illumination device and/or the imaging device can each be fixedly secured at the distal terminuses of lumens 122 and 123, or each can be slidable within lumens 122 and 123 to allow advancement further distally from outer shaft 120 and/or retraction into outer shaft 120. In one example embodiment, the illumination device and the imaging device are mounted together and only a single lumen 122 or 123 is present for that purpose. The remaining lumen (e.g., lumen 124) can be configured as an irrigation or flush port from which fluid such as saline can be introduced to the urethra to flush the region and provide adequate fluid through which implant 102 and the surrounding prostatic urethra wall can be imaged.

[0044] Outer shaft 120 has a proximal end (not shown) coupled with proximal control device 200. Delivery device 103 can be configured to be steerable to navigate tortuous anatomy. Steerability can be unidirectional (e.g., using a single pull wire) or multidirectional (e.g., using two or more pull wires arranged at different radial locations about device 103) depending on the needs of the application. In some embodiments, the structures (e.g., pull wires) for steerability extend from distal end region 104 of delivery device 103 (e.g., where the distal ends of the pull wires are secured to a plate or other structure within distal end region 104) to proximal control device 200, where they can be manipulated by the user to steer delivery device 103. The steering structures can be located in one or more lumens of outer shaft 120, or can be coupled to or embedded within a sidewall of outer shaft 120. Delivery device 103 can be biased to deflect in a particular lateral direction (e.g., bend) such that device 103 automatically deflects in that manner and forces imparted to steer delivery device 103 are in opposition to this biased deflection. Other mechanisms for steering delivery device 103 can also be used. The steering mechanism may also be locked or adjusted during deployment of implant 102 to control the position of implant 102 within the anatomy (e.g., steering anteriorly during deployment may help place implant 102 in a more desirable anterior position).

[0045] Inner shaft 130 can include one or more inner lumens for housing one or more implants 102 and/or other components. In this embodiment, inner shaft 130 includes a first lumen 131 in which one or more implants 102 can be housed, and a second lumen 132 in which third elongate tubular member 140 can be housed. In this embodiment, third elongate tubular member 140 is configured to releasably couple with the distal end region of implant 102 and is referred to as a distal control member or tether 140. Distal control member 140 can be slidably advanced and/or

2019271283 23 Jan 2025

retracted with respect to inner shaft 130. Distal control member 140 can include an inner lumen 141 that houses fourth elongate tubular member 150, which is shown here extending from an open distal terminus of distal control member 140. Fourth elongate tubular member 150 is configured to anchor delivery device 103 with respect to the patient's anatomy, e.g., to keep components of delivery device 103 stationary with respect to the anatomy during deployment of implant 102, and is referred to as anchor delivery member 150.

[0046] In the configuration depicted in FIG. 2A, anchor delivery member 150 is extended from lumen 141 of distal control member 140, and distal control member 140 along with inner shaft 130 are shown extended from lumen 121 of outer shaft 120. When delivery device 130 is advanced through the urethra, anchor delivery member 150 is preferably housed entirely within distal control member 140, and distal control member 140 along with inner shaft 130 are retracted from the positions shown in FIG. 2A such that they reside within lumen 121 of outer shaft 120 and do not extend from the open distal terminus of lumen 120. In other words, in some embodiments the open distal terminus of outer shaft 120 forms the distalmost structure of device 103 upon initial advancement through the urethra. This facilitates steering of delivery device 103 by outer shaft 120. The physician can advance distal end region 104 of delivery device 103 to be in proximity with the desired implantation site, or entirely into the patient's bladder. Anchor delivery member 150 can be exposed from the open distal terminus of distal control member 140, either by distally advancing anchor delivery member 150 further into the bladder, or if already present within the bladder, then by proximally retracting the other components of delivery device 103. At this point the anchor from anchor delivery member 150 can be deployed in the bladder.

[0047] The placement of these components within system 100 is not limited to the embodiments described with respect to FIG. 2A. In some embodiments, outer shaft 120 can be omitted altogether. In such embodiments, visualization of the deployment procedure can be accomplished with external imaging such as fluoroscopy, where implant 102 and delivery device 103 can be radiopaque or can include radiopaque markers, and where the imaging and illumination lumens 122 and 123 (and the imaging and illumination devices), as well as the irrigation lumen are omitted. In some embodiments, instead of distal control member 140 being slidably received within inner shaft 130, distal control member 140 can be slidable within a lumen of outer shaft 120 (either the same lumen receiving inner shaft 130 or a different lumen).

2019271283 23 Jan 2025

Similarly, instead of anchor delivery member 150 being slidably received within distal control member 140, anchor delivery member 150 can be slidable within a lumen of outer shaft 120 (either the same lumen receiving inner shaft 130 and/or anchor delivery member 150 or a different lumen) or a lumen of inner shaft 130 (either the same lumen receiving distal control member 140 or a different lumen). In some embodiments, outer shaft 130 has a separate and distinct lumen for each of members 130, 140, and 150, and can be configured to deploy implant 102 around members 140 and 150.

[0048] FIG. 2B is a perspective view depicting distal end region 104 of delivery device 103 with the various components deployed. In this embodiment, anchor delivery member 150 includes an anchor 152 in the form of an inflatable member or balloon. Other embodiments of anchors 152 are described with respect to FIGs. 4A-4G. Anchor 152 expands (or otherwise transitions) to a size greater than that of the bladder neck such that anchor 152 resists proximal retraction (e.g., a relatively light tension). In embodiments where anchor 152 is a balloon, that balloon can be an elastic or inelastic and inflatable with an inflation medium (e.g., air or liquid such as saline) introduced into balloon 152 through one or more inflation ports 153. Here three inflation ports 153 are located on the shaft of anchor delivery member 150 and communicate with an inflation lumen that extends proximally back to proximal control device 200, which can include a port for inflation with a syringe. Upon deployment of anchor 152, the physician can proximally retract delivery system 100 until anchor 152 is in contact with the bladder neck and/or wall (if not already).

[0049] The physician can use the imaging device of outer shaft 120 to move delivery device 103 proximally away from anchor 152 until the physician is in the desired position within the urethra to begin deployment of implant 102. A retainer 142 on distal control member 140 is releasably coupled with distal engagement member 114 of implant 102. The physician can position retainer 142 in a location along the length of the urethra where the physician desires the distal end of implant 102 to deploy. This can involve moving distal control member 140 and inner shaft 130, together, proximally and/or distally with respect to anchor delivery member 150. In another embodiment, the position of retainer 142 is fixed with respect to anchor 152 such that the longitudinal position of implant 102 within the anatomy is set by the system independently of any manipulation by the physician. The coupling of distal engagement member 114 with retainer 142 also permits the physician to manipulate the radial orientation of implant 102 by

2019271283 23 Jan 2025

rotating distal control member 140 and inner shaft 130 together. Active or passive shaping of distal control member 140 may allow for a more desirable placement of implant 102. For example, member 140 may have a curvature that places the implant in a more anterior anatomical position. This curvature may be inherently set in member 150 or actively applied by the physician through a separate entity such as a control wire. Once in the desired location and orientation, the physician can proximally retract inner shaft 130 with respect to distal control member 140 to initiate deployment of implant 102.

[0050] Distal engagement member 114 is held in place with respect to distal control member 140 by retainer 142, and proximal retraction of inner shaft 130 with respect to distal control member 140 causes ring-shaped structures 111 to begin to deploy in sequence (111a, then 111b, then 111c, then 111d (not shown)). Distal control member 140 can remain stationary or be moved longitudinally with respect to the urethra during deployment. In some embodiments, distal control member 140 is steerable to allow for angulation of implant 102 to accommodate relatively tortuous anatomy. Mechanisms for accomplishing steerability are discussed elsewhere herein and can likewise be applied to distal control member 140. In these or other embodiments, distal control member 140 can be significantly flexible to passively accommodate tortuous anatomy. In some embodiments, distal control member 140 has a predefined curve to assist in navigation.

[0051] To assist in deployment, inner shaft 130 can rotate clockwise and counterclockwise (as depicted by arrow 134) about distal control member 140. Referring back to FIGs. 1B-1C, implant 102 has a non-constant direction of winding that, when viewed as commencing at distal engagement member 114, proceeds clockwise along ring-shaped structure 111a, then reverses along interconnect 112a to a counterclockwise direction for ring-shaped structure 111b, then reverses along interconnect 112b to a clockwise direction for ring-shaped structure 111c, and then reverses along interconnect 112c to a counterclockwise direction for ring-shaped structure 111d, until ending at proximal engagement member 115. Depending on the direction of winding of the portion of implant 102 about to exit the open distal terminus of lumen 131, the transition of implant 102 towards the at-rest configuration can impart a torque on shaft 130 if shaft 130 is not actively rotated as implant 102 is deployed. That torque can cause shaft 130 to passively rotate (without user intervention) either clockwise or counterclockwise accordingly. In certain embodiments described elsewhere herein, shaft 130 is actively rotated during deployment.

2019271283 23 Jan 2025

Rotation of inner shaft 130 with respect to distal control member 140 thus allows delivery device 103 to rotate and follow the direction of winding of implant 102. In some embodiments, all ring-shaped structures 111 are wound in the same direction, clockwise or counterclockwise (e.g., as in the case of a fully spiral or helical implant), or do not have a set direction of winding.

[0052] In this or other embodiments, the distal end region of inner shaft 130 is configured to be relatively more flexible than the more proximal portion of inner shaft 130, which can permit avoidance of excessive motion of the rest of device 103 during deployment, resulting in better visualization and less tissue contact by device 103. Such a configuration can also reduce the stress imparted on implant 102 by device 103 during delivery. For example, the portion of inner shaft 130 extending from outer shaft 120 during deployment can be relatively more flexible than the portion of inner shaft 130 that remains within outer shaft 120, thus allowing inner shaft 130 to flex more readily as implant 102 exits inner lumen 131. This in turn can stabilize delivery device 103 and allow the physician to obtain stable images of the appointment process.

[0053] FIG. 2B depicts implant 102 after three ring-shaped structures 111a, 111b, and 111c have been deployed. Proximal retraction of shaft 130 continues until the entirety of implant 102, or at least all of ring-shaped structures 111, have exited lumen 131. If the physician is satisfied with the deployed position of implant 102 and the deployed shape of implant 102, then implant 102 can be released from delivery device 103.

[0054] Release of the distal end of implant 102 can be accomplished by releasing retainer 142. Retainer 142 can be a cylindrical structure or other sleeve that linearly or rotationally actuates over a cavity or recess in which a portion of implant 102 is housed. In the embodiment of FIG. 2B, retainer 142 includes an opening or slot that allows distal engagement member 114 to pass therethrough. Retainer 142 can rotate with respect to the cavity or recess in which distal engagement member 114 (not shown) is housed until the opening or slot is positioned over member 114, at which point member 114 is free to release from distal control member 130. Rotation of retainer 142 can be accomplished by rotation of a rotatable shaft, rod or other member coupled with retainer 142 (and accessible at proximal control device 200).

[0055] FIGs. 2C and 2D are perspective views depicting another example embodiment of system 100 with a different embodiment of retainer 142 shown in more detail. Here, retainer 142 slides distally and/or proximally with respect to distal control member 140. Distal engagement member 114 of implant 102 can be received within a corresponding recess of distal control

2019271283 23 Jan 2025

member 140. Retainer 142 can slide over distal engagement member 114 while received within this recess until retainer 142 abuts a stepped portion of member 140. A control wire 146 extends within the length of control member 140, either in the same lumen as anchor delivery member 150 or in a different lumen. Control wire 146 couples with retainer 142 with an enlarged portion 147 from which control wire 146 can be routed into member 140 through an opening 148.

[0056] Engagement member 114 can be placed within the recess and retainer 142 can be advanced over engagement 114 to secure the distal end of implant 102 to control member 140. Upon satisfactory deployment of implant 102 within the urethra, e.g., in the state of FIG. 2C, retainer 142 can be proximally retracted with control wire 146 to expose engagement member 114 and permit its release from member 140. FIGs. 2E and 2F are perspective views depicting another embodiment of system 100 with another configuration for retainer 142 that operates in similar fashion to that described with respect to FIGs. 2C and 2D. Here, implant 102 is not shown and recess 143 in which distal engagement member 114 can be received is shown in more detail.

[0057] FIGs. 2G and 2H are side and perspective views, respectively, of another example embodiment of system 100. In this embodiment, inner shaft 130 includes a flexible distal extension 160 in which is located inner lumen 131 (not shown). In this configuration, the open distal terminus of lumen 131 is located distal to the open distal terminus of lumen 132 (not shown) from which distal control member 140 extends. Lumens 122, 123, and 124 (not shown) are located on outer shaft 120 opposite to distal extension 160. Flexible distal extension 160 contributes to the flexibility to stabilize the delivery system, as well as to stabilize the image. Flexible extension 160 helps align ring-shaped structures 111 in a planar manner, and helps vector implant 102 (e.g., point radially) toward the urethral wall during deployment.

[0058] Release of the proximal end of implant 102 is also controllable. FIG. 3A is a partial cross-sectional view depicting an example embodiment of system 100 with a portion of implant 102 shown within inner lumen 131 of inner shaft 130. Here, implant 102 is in the lineated state prior to deployment with proximal engagement member 115 coupled with a grasper 136 that is slidable distally and/or proximally within lumen 131. Grasper 136 can include a distal end region 137 on or coupled with a shaft 138. Grasper 136 is preferably controllable to rotate and longitudinally translate (e.g., push and pull) implant 102 with respect to inner shaft 130.

2019271283 23 Jan 2025

[0059] FIGs. 3B and 3C are perspective views depicting an example embodiment of distal end region 137 of grasper 136 without implant 102 and with implant 102, respectively. Grasper 136 includes a recess (also referred to as a cavity or pocket) 139 for receiving and holding proximal engagement member 115. Here, the enlarged portion 117 is retained within recess 139 by a distal necked down region having a relatively smaller width. While within inner lumen 131, the sidewalls of inner shaft 130 maintain proximal engagement member 115 within recess 139. When distal end region 137 exits inner lumen 131 (either by retracting inner shaft 130 with respect to grasper 136 or by advancing grasper 136 with respect to inner shaft 130), the restraint imparted by the inner shaft sidewalls is no longer present and engagement member 115 is free to release from grasper 136. Thus, when the physician is satisfied with placement of the deployed implant 102, distal engagement member 114 can be released by moving retainer 142 and permitting distal engagement member 114 to decouple from control member 140, and proximal engagement member 115 can be released by exposing grasper 136 from within inner shaft 130 and permitting proximal engagement member 115 to decouple from grasper 136.

[0060] Grasper 136 can also assist in loading implant 102. In some embodiments, application of a tensile force on implant 102 with grasper 136 (while the opposite end of implant 102 is secured, for example, by retainer 142) facilitates the transition of implant 102 from the at-rest configuration to a lineated configuration suitable for insertion of implant 102 into inner shaft 130.

[0061] Anchor delivery member 150 can have multiple different configurations and geometries (e.g., including those that extend in one direction across the bladder wall, two directions across the bladder wall (e.g., left and right), or three or more directions across the bladder wall). FIGs. 4A-4B are cross-sectional views depicting an example embodiment of anchor delivery member 150 in various stages of deployment within a patient's body. In FIG. 4A, anchor delivery member 150 has been advanced through urethra 401 until open distal end 151 is past the bladder neck and within bladder 402, although in this and other embodiments end 401 can be stopped prior to entering bladder 402. Here, two anchoring arms 408a and 408b are housed within an inner lumen of anchor delivery member 150. In other embodiments, anchoring arms 408 can each be housed in a separate lumen within member 150. Anchoring arms 408 can be distally advanced with respect to anchor delivery member 150 (or anchor delivery member 150 can be advanced into bladder 402 and proximally retracted with respect to anchoring arms 408) such

2019271283 23 Jan 2025

that upon exiting open distal end 151, deflectable portions 410a and 410b transition laterally into contact with the bladder wall forming anchor 152 as depicted in FIG. 4B.

[0062] Anchoring arms 408 can be formed of a shape retentive material that is biased towards the at-rest configuration of FIG. 4B. The distal ends of anchoring arms 408 can each have an atraumatic terminus as depicted here (e.g., rounded, spherical, ballized) and, or alternatively, the distal ends of arms 408 can curve away from the bladder wall for added atraumatic effect. In other embodiments, only one anchoring arm 408 is used. FIG. 4C is a cross-sectional view depicting another example embodiment of anchor delivery member 150. Here, deflectable portions 410a and 410b have a generally straight or lineated shape and deflect from a shared shaft 412 that is slidable distally and/or proximally with respect to anchor delivery member 150. In all of the anchoring embodiments described herein, the one or more deflectable portions can deflect from a shared shaft (such as depicted here) or from separate shafts (such as depicted in FIGs. 4A-4B).

[0063] FIGs. 4D-4E are partial cross-sectional views depicting another example embodiment of anchor delivery member 150. FIG. 4D depicts this embodiment with anchor 152 in a state of partial deployment from open distal end 151 of anchor delivery member 150. FIG. 4E depicts anchor 152 after full deployment within bladder 402. Here, anchor 152 includes laterally deflectable struts 420a, 420b, 421a, and 421b connected by hinges 422a, 422b, and 422c. Specifically, laterally deflectable struts 420a and 421a are connected by hinge 422a, laterally deflectable struts 420b and 421b are connected by hinge 422b, and struts 421a and 421b are connected by hinge 422c. Again, anchor 152 is biased towards the at-rest configuration depicted in FIG. 4E and automatically transitions towards this configuration once exposed from within the inner lumen of anchor delivery member 150. Hinges 422 can each be implemented as a living hinge such as depicted in FIG. 4E, e.g., defined by a reduced with or relatively more flexible section of the device. Other hinge configurations can also be utilized.

[0064] In another embodiment, a pull wire or other member 424 is attached to one or more of struts 421 and/or hinge 422c and extends proximally to proximal control device 200. In FIG. 4E, pull member 424 is shown with a dashed line to indicate that it is optional. Proximal retraction of pull member 424 at proximal control device 200 causes the structural arrangement to laterally deflect into the configuration depicted in FIG. 4E. This arrangement provides a significant locking force while tension is maintained on pull member 424.

2019271283 23 Jan 2025

[0065] FIG. 4F is a partial cross-sectional view depicting another example embodiment of anchor delivery member 150. Here, a shape retentive element 430 has been advanced from within the inner lumen of anchor delivery member 150 where it was in a relatively straight or lineated shape. Upon exiting open distal end 151, the distal portion of element 430 automatically transitions towards a laterally expanded shape 432, which in this embodiment is in the shape of a coil or spiral. FIG. 4G depicts another example embodiment where the laterally expanded shape 432 has multiple loops and resembles a numeral “8” or a bowtie. Many different shapes can be utilized for laterally expanded shape 432 in addition to those depicted here. In all of the anchoring embodiments, the distal termini of the wires or elements exposed to the body tissue can have a rounded or enlarged atraumatic end (as depicted in FIGs. 4F and 4G).

[0066] Upon completion of the implant deployment procedure, anchor 152 can be collapsed or retracted to permit removal of delivery device 103. For instance, in embodiments where anchor 152 is a balloon, that balloon is deflated and optionally retracted back into a lumen of device 103, and subsequently withdrawn from the bladder and urethra. In embodiments where anchor 152 is a wire form or other expandable member (such as those described with respect to FIGs. 4A-4G), anchor 152 is retracted back into the lumen of device 103 from which it was deployed, and device 103 can subsequently be withdrawn from the bladder and urethra. Retraction can be accomplished using fluid or pneumatic actuation, a screw type mechanism, or others.

[0067] In FIG. 2B, anchor 152 is a generally spherical balloon with anchor delivery member 150 extending through the center. In other embodiments, balloon anchor 152 can be laterally offset, or positioned on only one side of anchor delivery member 150. FIG. 4H is a partial cross-sectional view depicting an example embodiment having a laterally offset balloon 152. Here the laterally offset balloon 152 exerts force on the side of bladder neck 403, and forces anchor delivery member 150 (and delivery device 103) in direction 450.

[0068] In other embodiments device 103 can include two or more balloons that can independently inflate in different lateral directions. Independent inflation of one or more balloons while maintaining the one or more remaining balloons in a deflated state can allow the user to change the angle of the delivery catheter relative to the anatomy, and thus allow for deployment of the implant in anatomy with significant curvatures. FIG. 4I depicts another example embodiment where a first anchor balloon 152a is inflated to a larger size than a second anchor balloon 152b located on the opposite side of member 150. As a result of the forces

2019271283 23 Jan 2025

exerted on the bladder wall, member 150 is tilted away from the smaller balloon 152b in direction 451. Selection of the appropriate balloon or balloons for inflation can be performed by the physician and the process of inflation and deflation can be repeated until the physician achieves a desirable angular orientation of device 103 within the anatomy, at which point the rest of the delivery procedure can be performed. Delivery member 150 can be a flexible or rigid shaft pre-shaped in a manner which will not impede the ability of implant 102 to be placed in a desirable anatomical position. For example, curvature in member 150 just proximal to the balloon mount location may allow implant 102 to be placed more anteriorly without constraint from the bladder neck.

[0069] In some embodiments, a shaped balloon or substantially elastic balloon can be inflated at the same location as the bladder neck. FIG. 4J depicts an example embodiment where balloon 152 is inflated at bladder neck 403. Here, balloon 152 includes a first lobe 155 formed in bladder 402 and a second lobe 156 formed in urethra 401. This configuration can be used to anchor member 150 directly over bladder neck 403.

#### Example Embodiments of Proximal Control Devices and Related Methods

[0070] FIG. 5A is a side view depicting an example embodiment of delivery system 100 prior to deployment of implant 102, and FIG. 5B is a side view depicting this embodiment with implant 102 in a deployed configuration (anchor delivery member 150 and distal control member 140 are not shown). In this embodiment proximal control device 200 is a handheld device having a handle 201, a first user actuator 202 (configured in this example as a trigger), a main body 203, and a second user actuator 205. A longitudinal axis of delivery device 103 is indicated by dashed line 204. Proximal control device 200 can include mechanisms that are manually powered by actuation of actuator 202 to cause relative motions of the components of device 103. In other embodiments, proximal control device 200 can utilize electrically powered mechanisms instead. Second user actuator 205 can be configured to control steering of delivery device 103. Here, actuator 205 is configured as a rotatable wheel that can wind or unwind a pull wire (not shown) within delivery device 103 and cause deflection of device 103 upwards and downwards as depicted here.

[0071] FIG. 6A is an interior view of proximal control device 200 that depicts various mechanical assemblies or subassemblies within a main housing 203 of control device 200. In

2019271283 23 Jan 2025

this embodiment, proximal control device 200 is configured to perform three types of motion on implant 102, namely, distal advancement of implant 102 along axis 204 (e.g., pushing), proximal retraction of implant 102 and/or inner shaft 130 along axis 204 (e.g., pulling), and rotation of inner shaft 130 about axis 204 (e.g., rotation). In other embodiments, depending on the delivery functions desired, proximal control device 200 can be configured to perform any subset of one or two of the aforementioned types of motion, to perform these types of motion but imparted on different components, or to perform other types of motion not mentioned here.

[0072] In this embodiment, proximal control device 200 includes a longitudinally translatable member 601 that, in this embodiment, is configured as a yoke. Yoke 601 is coupled with trigger 202 such that depression of trigger 202 causes proximal longitudinal translation of yoke 601. Yoke 601 is coupled with two proximally-located ratchet members 602 and 603 that, in this embodiment, are configured as pawls. Pawl 602 has a set of teeth that oppose corresponding teeth on pawl 603, and the teeth of each pawl 602 and 603 can interface or engage with complementary teeth on a gear 605 (see FIG. 6B), referred to herein as a pinion gear, that is part of a first gear assembly 600.

[0073] A switch 604 is accessible to the user and can be shifted between two positions, where each position is responsible for bringing only one of pawls 602 and 603 into engagement with pinion gear 605. Each of pawls 602 and 603 are deflectable and biased (e.g., with the spring) towards engagement with pinion gear 605. In this embodiment, placement of switch 604 in a downward position moves pawl 602 out of engagement with pinion gear 605 and moves pawl 603 into engagement with pinion gear 605. The proximal movement of yoke 601 and pawl 603 causes pinion gear 605 to rotate counterclockwise. Placement of switch 604 in an upward position reverses the engagement and places pawl 602 into engagement with pinion gear 605 and the proximal movement of yoke 601 and pawl 602 causes pinion gear 605 to rotate clockwise.

[0074] In this embodiment, first gear assembly 600 includes pinion gear 605, a second gear 610, a third gear 612, and a fourth gear 614. In other embodiments, first gear assembly 600 can be implemented to achieve the same or similar functionality with more or less gears than those described here.

[0075] Pinion gear 605 is engaged with second gear 610, which is oriented perpendicular to pinion gear 605. Pinion gear 605 has teeth that project from the radial edge of gear 605 while the second gear 610 has teeth that project from both distal face and a proximal face of the gear 610,

2019271283 23 Jan 2025

which is referred to herein as face gear 610. Counterclockwise rotation of pinion gear 605 will cause rotation of face gear 610 in a first direction and clockwise rotation of pinion gear 605 will cause rotation of face gear 610 in a second, opposite direction. The direction of rotation of face gear 610 in turn determines whether implant 102 is proximally retracted or distally advanced with respect to housing 203.

[0076] FIG. 6B is a perspective view depicting the interior of this embodiment of proximal control device 200 in more detail. The proximally facing teeth on face gear 610 engage with teeth on gear 612, referred to as an input gear. The teeth of input gear 612 are engaged with teeth of gear 614. Gear 614 is coupled with, or integrated with, a reel 616 that is configured to house or hold grasper shaft 138. As can be seen in the embodiment of FIGs. 9A-9B, reel 616 can include an optional groove or channel 617 in which grasper shaft 138 can be received. Rotation of reel 616 causes grasper shaft 138 to be wound onto reel 616 or unwound from reel 616 depending on the direction of rotation. Winding of grasper shaft 138 onto reel 616 corresponds to proximal retraction of implant 102 (e.g., into inner shaft lumen 131), while unwinding of grasper shaft 138 from reel 616 corresponds to distal advancement of implant 102 (e.g., out of inner shaft lumen 131). In the embodiment of FIGs. 9A-9B, channel 617 is a helical channel that extends about the circumference of reel 616 multiple times. In the embodiment depicted in FIG. 6B, channel 617 is omitted.

[0077] In some embodiments, input gear 612 can be configured as an interrupted gear, where one or more teeth are not present such that rotation of input gear 612 will not cause corresponding rotation of another gear at all times. An example of such an input gear 612 is depicted in the perspective view of FIG. 6C. From the perspective depicted here, input gear 612 has teeth 620 spaced at regular intervals on the left side 621 of the radial edge of the gear. Teeth 620 are also present at regular intervals on the right side 622 of the radial edge of the gear except for a region 623 where no teeth are present. A smooth surface hub 624 is present adjacent this interrupted region 623. The right side 622 of input gear 612 is configured to engage with reel gear 614. Placement of interrupted region 623 is predetermined such that continuous user depression of trigger 202 (and thus continuous rotation of pinion gear 605, face gear 610, and input gear 612) does not translate into continuous rotation of reel gear 614. Instead, reel gear 614 will only be turned when engaged with the portion of input gear 612 having teeth 620 and will not be turned while interrupted region 623 is traversing reel gear 614. Placement of

2019271283 23 Jan 2025

interrupted region 623 allows for a pause in longitudinal translation (e.g., distal and/or proximal) of grasper shaft 138. Interrupted region 623 is specifically placed such that longitudinal translation only occurs during certain parts of the delivery sequence.

[0078] In this embodiment, placement of switch 604 in the down position translates user depression of trigger 202 into pushing of implant 102, while placement of switch 604 in the up position translates user depression of trigger 202 into pulling of implant 102 and/or inner shaft 130. In other embodiments, these switch positions can be reversed to cause the opposite motions.

[0079] FIG. 7A is a top down view depicting a cam assembly 702 of proximal control device 200. Cam assembly 702 includes an outer slotted tube or cam 703, an inner slotted tube 704, and a guide member 706. Cam assembly can be positioned within yoke 601. FIG. 7B is a perspective view depicting this embodiment of cam 703. Cam 703 is coupled with face gear 610 such that rotation of face gear 610 also rotates cam 703. Inner slotted tube 704 is mounted within proximal control device 200 such that it does not rotate when cam 703 rotates. Guide member 706 can be configured as an arm or strut member that is located within and follows both a slot 710 in cam 703 and a slot 714 in inner tube 704. Guide member 706 is coupled with a hub 802 (FIG. 8) located within inner slotted tube 704 that is in turn coupled with inner shaft 130 (e.g., by way of a main shaft that can, in some embodiments, include a multi-sided shaft 708 and rotary adapter 1112 as described with respect to FIG. 11E). Rotation of face gear 610 causes rotation of cam 703 which in turn causes guide member 706 to follow the path or route of slot 710 in cam 703. Because guide member 706 extends through slot 714 in inner tube 704, which is not rotatable, rotation of cam 703 causes guide member 706 to move only in a longitudinal direction and not a radial direction.

[0080] Slot 710 can have one or more sloped slot portions and/or one or more radial slot portions. In the embodiment depicted here, slot 710 has multiple sloped portions (e.g., slot portions 717a, 717b, and 717c) and multiple radial portions (e.g., slot portions 719a, 719b, 719c, and 719d). Other shapes can be used as well and linked together to form the desired path. Sloped slot portions 717 can have a constant or variable slope, and in some embodiments, these sloped slot portions can vary such that the slope reverses from positive to negative (like a “V”).

[0081] A sloped slot portion 717 can be an opening or groove in cam 703 with a non-perpendicular and non-parallel angle (with respect to longitudinal axis 204) that moves guide

2019271283 23 Jan 2025

member 706 along longitudinal axis 204 during rotation. A radial slot portion 719, in most embodiments, is parallel to longitudinal axis 204 such that rotation of cam 703 moves radial slot portion 719 with respect to guide member 706 while guide member 706 does not move in the longitudinal direction (proximally or distally). Radial slot portion 719 can correspond to a pause in the delivery sequence where trigger 202 is continuing to be depressed and other components of delivery device 103 are moving but inner shaft 130 remains in the same relative position.

[0082] In FIG. 7A, guide member 706 is located at the distal most terminus within radial slot portion 719a (FIG. 7B). For retraction of inner shaft 130, cam 703 is rotated in counterclockwise direction 720. While cam 703 rotates radial slot portion 719a past guide member 706 there is no longitudinal movement of inner shaft 130. When guide member 706 reaches sloped slot portion 717a, it begins to proximally retract along with inner shaft 130. This process repeats as guide member 706 moves through the succession of radial slot portions 719 (e.g., pauses in shaft 130 retraction) and sloped slot portions 717 (e.g., retraction of shaft 130). In some embodiments, guide member 706 can be selectively coupled with outer shaft 120 to cause longitudinal movement of that component. For example, in proximally retracting inner shaft 130, outer shaft 120 can be proximally retracted as well, for example to allow the physician to continue imaging the deployment process. (See, e.g., the description with respect to FIGs. 11A-11E.) Similar embodiments utilizing a cam assembly, that can be used with the embodiments described here, are described in the incorporated Int'l Publ. No. WO 2017/184887.

[0083] Proximal control device 200 can also be configured to rotate inner shaft 130 with respect to distal control member 140 during extrusion of implant 102 from within inner lumen 131. FIG. 8 is a side view depicting an example embodiment of a second gear assembly 800 configured to translate rotation of face gear 610 into rotation of hub 707, which is in turn coupled with inner shaft 130, which in some embodiments is accomplished by way of an intermediately located multi-sided shaft 708 (see, e.g., FIGs. 6A and 11A) and rotary adapter 1104 (see, e.g., FIG. 11E). Gear assembly 800 is located distal to cam assembly 702 (see FIGs. 6A and 7A). Gear assembly 800 can include a first gear 802 coupled with cam 703 such that rotation of cam 703 causes rotation of gear 802. In this embodiment, gear 802 has an annular or ring-like shape with a first set of radially inwardly projecting teeth 804 and an interrupted region 806. Gear 802 can have a second set of radially inwardly projecting teeth (not shown) with an interrupted region that are located in a plane different from teeth 804.

2019271283 23 Jan 2025

[0084] Gear assembly 800 can also include translation gears 810, 812, and 814, which can also be referred to as planetary gears, which translate rotation of gear 802 to a centrally located gear 816. In this example, the first set of teeth 804 engages with gear 810, which in turn engages with and rotates central gear 816 in a first direction. Central gear 816 has an aperture in which hub 707 is rotationally secured but free to slide longitudinally. Thus, rotation of gear 802 is translated to rotation of hub 707, which in turn rotates inner shaft 130. The second set of teeth of gear 802 (not shown) engages with gear 812, which in turn is engaged with gear 814, which in turn is engaged with central gear 816 and causes rotation of central gear 816 in the opposite direction. Depending on the positions of the first and second sets of teeth, and the interrupted regions in the various planes, constant rotation of annular gear 802 in one direction can translate into timed rotation of central gear 816 in the same direction, in the opposite direction, or no rotation of central gear 816 at all.

[0085] The delivery sequence of the three stages can be described relative to corresponding features of implant 102. Each ring-shaped structure 111 and interconnect 112 is subjected to pushing by grasper 136. In some embodiments, implant 102 can be rotated by grasper 136 as well. In some embodiments, the total longitudinal push distance traveled by grasper 136 (provided by reel 616) in an implant delivery is roughly equivalent to the additive circumferences of all ring-shaped structures 111 of the embodiment of implant 102. The combined movement of pushing and rotating can ensure that, despite lateral forces impinged on the prostatic urethra, ring-shaped structures 111 of implant 102 are laid down in plane to provide sufficient radial force to open the cavity. Each interconnect 112 of implant 102 is subjected to the pulling stage (without rotation) by the hub and cam. Thus, the total axial pull distance traveled by the hub inside the cam is roughly equivalent to the total longitudinal length of implant 102. The pulling stage and pushing/rotation stage do not occur at the same time during the delivery sequence; they are mutually exclusive.

[0086] Proximal control device 200 can be configured so that, after all of ring-shaped structures 111 have been deployed from inner lumen 131 but prior to advancement of proximal engagement feature 115 and recess 139 from within lumen 131, further deployment of implant 102 is automatically prevented. This provides the physician with an opportunity to verify that implant 102 has been properly deployed and placed prior to releasing implant 102 from delivery device 103.

2019271283 23 Jan 2025

[0087] FIGs. 9A-9F are interior perspective views depicting an example embodiment of proximal control device 200 with a lock or locking mechanism 900 for preventing premature release of implant 102. Locking mechanism 900 interfaces with a groove or channel 902 in the proximally facing surface of face gear 610 as shown in FIGs. 9A-9B. A longitudinally, laterally, and radially inwardly movable tracking mechanism 904 has a head portion with a projection 905 and is biased distally such that projection 905 presses into and tracks within groove 902. As face gear 610 is rotated by pinion gear 605 (not shown), tracking mechanism 904 follows the spiral groove 902 and moves radially inwardly. This movement continues until implant 102 is almost fully deployed, but proximal engagement member 115 is still retained by grasper 136 within inner lumen 131. At this point, projection 905 enters a relatively deeper portion 906 of groove 902 (e.g., a cavity) which securely captures tracking mechanism 904. Further rotation of face gear 610 causes tracking mechanism 904 to move laterally or swivel in a semicircular arc to the position depicted in FIGs. 9C-9D, where an arm 907 of tracking mechanism 904 is prevented from further lateral motion by a fixed body 915. Further rotation of face gear 610 is prevented, which in turn prevents rotation of all gears and prevents the user from continuing to pull trigger 202.

[0088] If the physician is satisfied with placement of implant 102, then an unlock actuator or tab 910, which is accessible to the user outside of housing 203, is pulled proximally. Unlock tab 910 is coupled, directly or indirectly, to the control wire 146 responsible for releasing retainer 142 as described with respect to FIGs. 2C and 2D. Thus, the proximal movement of unlock tab 910 causes retainer 142 to move proximally and allows release of distal engagement member 114 of implant 102 from delivery device 103. Unlock tab 910 can also be coupled with tracking mechanism 904 such that proximal retraction of tab 910 withdraws projection 905 from within groove 902. This action unlocks device 200 and the user is free to continue depression of trigger 202, which in turn feeds reel 616 forward to further unwind grasper shaft 138 and cause proximal engagement member 115 of implant 102 and recess 139 to exit inner lumen 131 of shaft 130. At this stage both distal engagement member 114 and proximal engagement member 115 of implant 102 are exposed and implant 102 is free to disengage or release from device 103.

[0089] Proximal control device 200 can be configured to rotate distal control member 140 with respect to the other components of delivery device 103 to facilitate the removal of distal engagement member 114 from distal control device 140. In the embodiment depicted in FIG.

2019271283 23 Jan 2025

9E, a second cam 940 is rotatable within body 941. Distal control member 140 (not shown) is secured to cam 940 (e.g., with a set screw) such that rotation of cam 940 causes rotation of distal control member 140. Cam 940 has two sloped surfaces 944a and 944b that are in contact with two rigid members (e.g., pins) 946a and 946b, respectively, that are fixed to body 941 and located on opposite sides of cam 940. Cam 940 is rotatable but longitudinally fixed with respect to body 941. Pulling unlock tab 910 moves body 941 and members 946a and 946b proximally. Cam 940 cannot move proximally so the contact of members 946 on sloped surfaces 944 cause cam 940 to rotate, which in turn rotates distal control member 140. Thus, the retraction of tab 910 releases retainer 142 and rotates distal control member 140, which uncovers distal engagement member 114 of implant 102 (implant 102 is now expanded in contact with the urethra). The rotation assists in withdrawing distal engagement member 114 from recess 143 of member 140 and can ensure complete disengagement.

[0090] In some embodiments, distal control member 140 has a preset bend (not shown) proximal to retainer 142. Distal control member 140 is deformed from this preset bent shape when attached to distal engagement member 114 (e.g., as depicted in FIGs. 2B, 2G, and 2H), and thus is biased to return to this preset bent shape, which can also assist in the disengagement of member 140 from implant 102 (either instead of, or in addition to, embodiments where device 200 rotates member 140).

[0091] A stop surface 912 is present on tracking mechanism 904 that opposes another stop surface 914 on fixed body 915. In the position of tracking mechanism 904 shown in FIG. 9B, these opposing stop surfaces 912 and 914 prevent unlock tab 910 from being proximally retracted since body 915 is a separate component held in a static position (e.g., by housing 203). Lateral movement of tracking mechanism 904, e.g., in the semicircular arc, continues until stop surface 912 ceases and passes stop surface 914 as shown in FIG. 9D. This feature prevents premature unlocking of implant 102 by proximally retracting unlock tab 910 before implant 102 is sufficiently deployed.

[0092] Proximal control device 200 can also include an emergency release mechanism that permits removal of a partially deployed implant 102 from the patient. Unlock tab 910 can be decoupled from tracking mechanism 904 by disengaging a notch of a deflectable arm 920 from a detent 922 on the base of tracking mechanism 904. In other embodiments the notch and detent features can be reversed. An emergency release button 924 having a ramped surface 925 is

2019271283 23 Jan 2025

positioned underneath arm 920 (see FIGs. 9A-9B). Actuation, e.g., by pushing, release button 924 causes the ramped surface 925 to deflect arm 920 upwards and decouple the notch from detent 922 as depicted in FIG. 9E. In this state, unlock tab 910 is decoupled from tracking mechanism 904 and is free to be proximally retracted even while stop surfaces 912 and 914 are in opposing positions. Proximal retraction of unlock tab 910 retracts control wire 146 and releases distal engagement member 114 of implant 102 from distal control member 140. At this point, the partially deployed implant 102 is still attached to grasper 136, which can be proximally retracted into outer shaft 120 and then completely removed from the patient.

#### Example Embodiments of Delivery Methods

[0093] FIG. 10A is a flow diagram depicting an example embodiment of a method 1000 of delivering implant 102 using system 100. Distal end region of outer shaft 120 is inserted into the urethra, preferably with inner shaft 130, distal control member 140, and anchor delivery member 150 in retracted states fully contained within outer shaft 120 such that no part is extending from the open distal terminus of outer shaft 120. After advancement into the urethra, at step 1002 anchor delivery member 150 is advanced distally with respect to the remainder of delivery device 103 (e.g., members 120, 130, and 140) and used to deploy anchor 152 within the bladder. In some embodiments, deployment of anchor 152 can be the inflation of one or more balloons (e.g., as depicting in FIGs. 2B, and 4H-4J) by the introduction of an inflation medium through an injection (e.g., luer taper) port. FIG. 6A depicts tubing 650 for balloon inflation. In other embodiments deployment of anchor 152 can be the advancement of one or more wire-form members from anchor delivery member 150 such that they deflect into a position that opposes the bladder wall (e.g., FIGs. 4A-4G). The longitudinal positioning (e.g., advancement and retraction) of anchor delivery member 150 and/or any wire-form members can be accomplished manually by the user manipulating a proximal end of anchor delivery member 150 and/or any wire-form members either directly or with proximal control device 200.

[0094] At step 1004, anchor 152 can be held in tension against the bladder wall by exertion of a proximally directed force on device 200. Anchor 152 can therefore provide an ordinate for system 100 from which to deploy implant 102 in an accurate location. This feature can ensure the implant is not placed too close to the bladder neck.

[0095] At 1006, distal control member 140 and inner shaft 130 can then be distally advanced from within outer shaft 120 if they have not already (for example, step 1006 can occur prior to

23 Jan 2025

2019271283

steps 1002 and/or 1004). The user can manipulate the position of proximal control device 200 with the aid of imaging (as described herein) until implant 102 is in the desired position. Once implant 102 is in the desired position, the implant deployment procedure can begin. The steps for implant deployment can be performed automatically by user actuation of proximal control device 200 (e.g., actuation of trigger 202, selection of a position for switch 604, etc.), or the steps can be performed directly by hand manipulation of each component of delivery device 103, or by a combination of the two as desired for the particular implementation.

[0096] In some embodiments, deployment of implant 102 from within lumen 131 is fully accomplished by (1) distally advancing grasper 136 with respect to inner shaft 130, while inner shaft 130 is not moved, while in other embodiments, deployment of implant 102 from within inner lumen 131 is fully accomplished by (2) proximally retracting inner shaft 130 with respect to grasper 136 while grasper 136 is not moved. In some embodiments, deployment of implant 102 is fully accomplished by (3) a combination of both movements. In still other embodiments, deployment of implant 102 is fully accomplished by (1), (2), or (3) in combination with one or more rotations of inner shaft 130, in one or more directions (e.g., clockwise or counterclockwise) with respect to distal control member 140.

[0097] An example embodiment of a sequence of steps 1008, 1010, and 1012 for deploying implant 102 is described with reference to FIG. 10A and the timing diagram of FIG. 10B. First with reference to FIG. 10A, at step 1008 a first ring-shaped structure 111a is caused to exit lumen 131 of inner shaft 130, at step 1010 an interconnect 112 is caused to exit lumen 131, and at step 1012 a second ring-shaped structure 111b is caused to exit lumen 131. Steps 1010 and 1012 can be repeated for each additional interconnect 112 and ring-shaped structure 111 present on implant 102.

[0098] In FIG. 10B, step 1008 begins at the far left of the timing diagram at T0. Deployment of ring-shaped structure 111a corresponds to the duration of time marked 1008, deployment of interconnect 123 corresponds to time span 1010, and deployment of ring-shaped structure 111b corresponds to time span 1012. Those of ordinary skill in the art will recognize that the differentiations between deployment of a ring-shaped structure 111 and deployment of an interconnect 112 are approximations as the transitions between those portions of implant 102 can be gradual and do not have to have precise demarcations.

2019271283 23 Jan 2025

[0099] The embodiment described with respect to FIG. 10B is for an implant with ring-shaped structures 111 having opposite directions of winding (e.g., clockwise, then counterclockwise, then clockwise, etc.). Three different motions are indicated in FIG. 10B. At top is rotational motion of inner shaft 130 in one direction (e.g., clockwise), in the middle is longitudinal motion (e.g., proximal or distal) of one or more components of delivery device 103, and at bottom is rotational motion inner shaft 130 in the direction opposite (e.g., counterclockwise) that indicated at top. In embodiments where ring-shaped structures 111 of implant 102 are all wound in the same one direction, rotation of inner shaft 130 will also be in only one direction.

[0100] From time T0 to T1, deployment of implant 102 is accomplished by rotating inner shaft 130, as indicated in region 1031. At the same time, in region 1032, grasper 136, and thus implant 102, is distally advanced without moving outer shaft 120 longitudinally (neither distally nor proximally) nor rotationally, and also without longitudinally moving inner shaft 130 (neither distally nor proximally). By way of example, within proximal control device 200 the rotational movement of inner shaft 130 without corresponding longitudinal movement of both inner shaft 130 and outer shaft 120 is accomplished by the user depression of trigger 202 being translated (through the yoke and pawl) into rotation of pinion gear 605 and face gear 610. Rotation of face gear 610 also rotates cam 703 of cam assembly 702 (FIGs. 7A-7B) while guide member 706 is in a radial slot portion (e.g., 719a), and thus neither of shafts 120 and 130 move longitudinally. Rotation of cam 703 also causes second gear assembly 800 (FIG. 8) to rotate inner shaft 130. The advancement of grasper 136 is caused by face gear 610 rotating input gear 612, which in turn rotates reel gear 614 (FIGs. 6A-6B) and causes reel 616 to rotate and unwind grasper shaft 138 distally.

[0101] From time T1 to T2, rotation of inner shaft 130 is stopped but distal advancement of grasper 136 continues while shafts 120 and 130 do not move longitudinally. By way of example, within proximal control device 200, user depression of trigger 202 continues and cam 703 continues to rotate with guide member 706 in a radial slot portion (e.g., 719a). Rotation of cam 703 continues to rotate annular gear 802 of second gear assembly 800, but at this point an interrupted portion (without teeth) of annular gear 802 is reached none of planetary gears 810, 812, and 814 are rotated, and thus rotation of central gear 816 and inner shaft 130 is stopped. In this embodiment, deployment of first ring-shaped structure 111a is complete at time T2.

2019271283 23 Jan 2025

[0102] From time T2 to T4, deployment of a first interconnect 112 takes place. In region 1033, from time T2 to T4, no distal advancement of grasper 136 (and implant 102) occurs.

Deployment of interconnect 112 is accomplished by proximal retraction of both outer shaft 120 and inner shaft 130 while holding grasper 136 in place. This causes interconnect 112 to exit inner lumen 131 of shaft 130. By way of example, in proximal control device 200, user depression of trigger 202 continues and face gear 610 continues to rotate, as do both cam 703 and input gear 612. Interrupted portion 623 in input gear 612 is reached and rotation of input gear 612 no longer causes rotation of reel gear 614, and thus distal advancement of grasper shaft 138 is stopped. Within cam assembly 702, guide member 706 transitions from a radial slot portion (e.g., 719a) to a sloped slot portion (e.g., 717a), and rotation of cam 703 causes guide member 706 to move proximally. With guide member 706 coupled with shafts 120 and 130, these shafts 120 and 130 also move proximally.

[0103] With respect to rotation of inner shaft 130, from time T2 to T3 no rotation of inner shaft 130 occurs. Within proximal control device 200 the interrupted portion of annular gear 802 continues and there is no rotation of shaft 130 by central gear 816.

[0104] In embodiments where interconnect 112 is straight, then it can be desirable to refrain from rotating shaft 130 while interconnect 112 is deployed from time T2 to T4. For embodiments where interconnect 112 is curved, such as the embodiment of FIGs. 1B-1D, it may be desirable to initiate rotation of inner shaft 130 during interconnect deployment. FIG. 10B depicts deployment for a curved interconnect 112, and from T3-T4 inner shaft 130 is rotated in the opposite direction as indicated by region 1034. By way of example, within proximal control device 200, user depression of trigger 202 continues and this motion is translated to annular gear 802, which has a region with teeth come into engagement with the planetary gears responsible for motion of central gear 816 in the opposite direction. Rotation of central gear 816 in the opposite direction therefore begins and inner shaft 130 is likewise rotated in the opposite direction from that of times T0 to T1, which facilitates deployment of interconnect 112 and begins rotation of inner shaft in the direction appropriate for the oppositely wound second ring-shaped structure 111b.

[0105] At T4, deployment of interconnect 112 is complete and deployment of second ring-shaped structure 111b begins. Proximal retraction of shafts 120 and 130 is stopped as indicated by the cessation of region 1033. Distal advancement of grasper shaft 138 is restarted in region

2019271283 23 Jan 2025

1035 at T4, while outer shaft 120 is not moved rotationally nor longitudinally. Rotation of inner shaft 130 continues as indicated in region 1034, but inner shaft 130 is not moved longitudinally. By way of example, within proximal control device 200, the user continues to depress trigger 202. Rotation of cam 703 continues but guide member 706 reaches a second radial slot portion (e.g., 719b) and proximal movement of guide member 706 stops (as does retraction of shafts 120 and 130). Rotation of central gear 816 continues. Interrupted portion 623 of input gear 612 ceases and teeth 620 reengage with reel gear 614 causing rotation of both reel gear 614 and reel 616 to begin again, and thus distal advancement of grasper shaft 138 begins as well.

[0106] These motions continue until time T5, at which point rotation of inner shaft 130 is stopped. Within proximal control device 200, an interrupted portion of annular gear 802 is reached and gear 802 disengages from the planetary gears and rotation of central gear 816 is stopped. User depression of trigger 202 continues from time T5-T6, the components operate with similar motions as described from time T1 to T2. If another interconnect 112 and ring-shaped structure 111 are present, then the sequence beginning at time T6 can be the same as that described beginning at time T2 and continuing to time T6. This process can repeat as needed until all ring-shaped structures 111 of implant 102 are deployed. In some embodiments, further depression of trigger 202 can be stopped by lock mechanism 900 (FIGs. 9A-9B) to prevent premature deployment and release of proximal engagement portion 115.

[0107] In many embodiments described here, deployment of all of ring-shaped structures 111 can occur with a single continuous depression of trigger 202. In all of these embodiments, proximal control device 200 can instead be configured such that repeated pulls of trigger 202 are required to deploy all of ring-shaped structures 111 of implant 102.

[0108] During deployment, e.g., after time T0 up until completed deployment of the proximal-most ring-shaped structure 112, if the physician wishes to recapture implant 102, then depression of trigger 202 can be stopped. Trigger 202 can be spring-loaded or otherwise biased to return to the outermost position. The physician can adjust switch 604 from the position corresponding to deployment to a different position corresponding to recapture. This adjustment of switch 604 will disengage pawl 603 and engage pawl 602. The physician can again depress trigger 202 and that depression will translate into the reverse motion of face gear 610, which in turn translates into reverse motion of the remainder of first gear assembly 600, cam 703, and second gear assembly 800. For example, if switch 604 is adjusted at any time between times T0 and T6, then

2019271283 23 Jan 2025

the next depression of trigger 202 will cause the sequence of events to be reversed going from right to left in FIG. 10B. Because these motions are merely a reversal of that already described, they will not be repeated here.

[0109] If the physician is satisfied with deployment, then at 1014 distal engagement portion 114 and proximal engagement portion 115 of implant 102 can be released from distal control member 140 and grasper 136, respectively. By way of example, in proximal control device 200 the physician can pull tab 910 to permit trigger 202 to be depressed the rest of the way, which in turn can deploy proximal engagement portion 115 of implant 102, either by distal advancement of grasper 136, proximal retraction of shafts 120 and 130, or both. Tab 910 can be coupled with control wire 146 and the pulling of tab 910 can pull wire 146 and remove retainer 142 from distal engagement portion 114.

[0110] Anchor 152 can then be recaptured (e.g., deflation of the balloon or retraction of the wire-form members) and withdrawn into anchor delivery member 150 if desired. Anchor delivery member 150, distal control member 140, and inner shaft 130 can be retracted into outer shaft 120 and then withdrawn from the urethra.

#### Example Embodiments of User Assembly of Proximal Control Device

[0111] Referring back to FIG. 5A, proximal control device 200 can include a movable (e.g., retractable and/or advanceable) handle portion 1102 that can move with respect to the more proximally located handle portion 1103. FIG. 5A depicts movable handle portion 1102 in a distally advanced position prior to deployment of implant 102 and FIG. 5B depicts portion 1102 in a proximally retracted position after deployment of implant 102. Movable portion 1102 can be secured to and moved with outer shaft 120, and can also be moved independently of inner shaft 130, distal control member 140, and anchor delivery member 150 (not shown).

[0112] FIG. 11A is an interior view of an example embodiment of movable portion 1102 of proximal control device 200 taken from a view that is reversed as compared to FIGs. 5A-5B. Proximal end region 105 of delivery device 103 is shown coupled with housing 1103 of movable portion 1102 at right, and multi-sided shaft 708 is shown at left. (Shaft 708 can be multi-sided to allow an interference fit with hub 707, although other configurations and securement techniques can be used such that shaft 708 is cylindrical (e.g., secured to hub 707 with adhesive). A coupling mechanism 1106 is mounted or formed within housing 1103 and will be described in

2019271283 23 Jan 2025

more detail with respect to FIGs. 11B-11E. Also included within housing 1103 is imaging hardware 1202, which will be described in more detail with respect to FIGs. 12A-12E.

[0113] FIG. 11B is an interior view of coupling mechanism 1106 depicted from a closer perspective than FIG. 11A. Here, coupling mechanism 1106 includes a user actuator 1107 that is configured in this embodiment as a latch slidable within a track 1108 provided by housing 1109. FIG. 11C depicts coupling mechanism 1106 with a proximal side of housing 1109 removed to permit the interior components to be seen. FIG. 11D depicts the coupling mechanism 1106 of FIG. 11C also with latch 1107 removed, and FIG. 11E depicts the coupling mechanism 1106 of FIG. 11D with housing 1109 removed, to further ease description.

[0114] Latch 1107 is coupled with an elastic, deflectable member 1110 that is seated within housing 1109. Movement of latch 1107 from a leftmost position to a rightmost position (as depicted here) causes member 1110 to bend against a sloped surface 1119. Member 1110 is biased towards a straight configuration (as shown in FIGs. 11C-11D) and release of latch 1107 in the rightmost position permits latch 1107 return to the leftmost position by the elastic action of member 1110. Member 1110 can be configured as desired for the needs of the application. For example, in this embodiment member 1110 is a nitinol wire.

[0115] When in the leftmost position member 1110 can be received within one or more grooves in rotary adapter 1112. In the embodiment of FIG. 11E there are two grooves 1114 and 1115, each of which can receive member 1110 such that member 1110 can slide in grooves 1114 and 1115 as rotary adapter 1112 is rotated, but any longitudinal movement (advancement and/or retraction) of rotary adapter 1112 will cause likewise movement to member 1110.

[0116] Prior to use in the implantation procedure, the proximal end of inner shaft 130 is coupled with rotary adapter 1112, which in turn is coupled with multi-sided shaft 708, which is in turn coupled with the proximal portion 1103 of proximal control device 200. The outer shaft 120 is coupled with movable portion 1102, but portions 1103 and 1102 are separated and not coupled together. The medical professional or other user can advance the distal end of inner shaft 130 into movable portion 1102 of proximal control device 200 until a groove 1114 and/or 1115 of rotary adapter 1112 engages with deflectable member 1110. The insertion of inner shaft 130 through portion 1102 can be accomplished with the aid of one or more ramps 1120 depicted in FIG. 11B. The distal end 1118 of rotary adapter 1112 can be tapered or necked down in one or more regions to assist in this insertion by deflecting member 1110 until the first groove 1115 is

23 Jan 2025

2019271283

located immediately adjacent thereto at which point member 1110 will snap into the groove. Upon engagement of wire 1110 with one of grooves 1114 or 1115, movable portion 1102 is coupled with proximal portion 1103 of proximal control device 200. In certain embodiments, at this point, proximal control device 200 is assembled and ready for use in the implantation procedure.

#### Example Embodiments of Imaging Devices and Use

[0117] In certain example embodiments, the coupling of movable portion 1102 (which is secured to outer shaft 120) to rotary adapter 1112 (which in turn is secured to multi-sided shaft 708, guide member 706, and inner shaft 130), causes outer shaft 120 to track the movements of inner shaft 130. As described with respect to FIG. 2A, an imaging device and illumination device (see FIGs. 12D-12E) can be placed in one or more of lumens 122-124 at the distal end of outer shaft 120. These devices can be mounted at the distal terminus of their respective lumens (or share a lumen), the locations of which are a small distance proximal to the distal terminus of inner shaft 130 from which implant 102 exits during delivery. As inner shaft 130 moves proximally in a longitudinal direction, outer shaft 120 also moves proximally in a longitudinal direction with the same spacing maintained between their relative distal terminuses. Conversely, as inner shaft 130 moves distally outer shaft 120 also moves distally with the same spacing maintained (i.e., at the same rate). As such, system 100 allows the delivery of implant 102 from inner shaft 130 to be imaged with a constant spacing from the distal terminus of inner shaft 130. Because grooves 1114 and 1115 are annular (e.g., ring-like extending about the periphery of rotary adapter 1112) inner shaft 130 is permitted to rotate without causing like rotation in outer shaft 120. Deflectable member 1110 simply slides along the respective groove 1114 or 1115.

[0118] If the user or medical professional desires the imaging device to be placed at a different spacing from the distal terminus of inner shaft 130, coupling mechanism 1106 can be used to release the coupling between movable portions 1102 and 1103, and movable portion 1102 can be moved such that a different groove engages with deflectable member 1110. For example, disengaging groove 1115 and engaging with groove 1114 will increase the spacing between the imaging device at the distal terminus of outer shaft 120 and the distal terminus of inner shaft 130, thus allowing the user to image with a relatively wider field of view. This feature provides the

2019271283 23 Jan 2025

user with the ability to adjust the field of view. Coupling mechanism 1106 can be coupled in a first position corresponding to a first one of grooves 1114 and 1115, and if the imaging field of view is not optimal, the user can uncouple mechanism 1106 and switch to a second position corresponding to the other one of grooves 1114 and 1115. Although in the embodiments described herein only two grooves 1114 and 1115 are present, any number of one, two, three, four, or more grooves can be used, each being independently selectable from the others and each corresponding to a different position and field of view. The ability of the imaging and illumination devices to automatically move in lockstep with the longitudinal movement of inner shaft 130 during deployment can be used with any embodiment described herein.

[0119] FIG. 12A depicts a housing 1203 for imaging hardware 1202. FIG. 12B depicts the components on the interior of housing 1203 and FIG. 12C depicts these components from a closer perspective. FIG. 12D is a perspective view depicting the proximal side of a distal end region of outer tubular member 120, and FIG. 12E is a perspective view depicting the distal side of the distal end region of outer tubular member 120. A first bus 1204, which in this embodiment is in the form of a ribbon cable, is connected at its distal end (FIG. 12D) to an imaging device 1220 in a distal end region tip 1224 of outer tubular member 120 (not shown). First bus 1204 can be routed through a lumen (e.g., one of lumens 122-124) of outer tubular member 120 and have its proximal end is connected to one or more contacts (FIG. 12C), in this example four contacts 1205-1208 for power, ground, the received signal, and a clock.

[0120] A second bus 1210, which in this embodiment is also in the form of a ribbon cable, is connected at its distal end (FIG. 12D) to an illumination device 1222 in distal end region tip 1224. Second bus 1210 can be routed through the same or a different lumen of outer tubular member 120 (e.g., one of lumens 122-124) and have its proximal end connected to one or more contacts (FIG. 12C), in this example two contacts 1211 and 1212 for power and ground. These contacts are located on a printed circuit board 1216 that can have additional imaging hardware (not shown) coupled thereto, including passive RLC components and active components (e.g., transistors, diodes, and/or semiconductor chips). The output circuitry to transmit the received images can be wireline circuitry that outputs the image via a cable to a display or wireless circuitry that transmits the images wirelessly to a local receiver with a display. A flush port lumen 1223 is also shown in FIGs. 12D-12E. The order of the positions of imaging device 1220,

illumination device 1222, and flush port lumen 1223 can be rearranged from the positions described and shown here.

#### Example Embodiments of Implant Placement

[0121] All the embodiments of system 100 described herein can be used to deliver implant 102 to various locations in proximity to the prostate gland, or other locations within the human anatomy. FIG. 13 is a cross-section of the male anatomy that provides context for use in describing various examples of implantation locations within the prostatic urethra. Here, prostate gland 1302 is centrally located with bladder wall 1304 and bladder 1305 located superiorly. The prostatic urethra 1306 extends inferiorly from bladder 1305 past ejaculatory duct 1307 and through prostate gland 1302. The prostatic urethra 1306 becomes the membranous urethra 1308 at the general location of the external urethral sphincter 1309 and continues on to exit the body. The rectum is indicated by 1310.

[0122] FIG. 14A is a cross-section rotated from the viewpoint of FIG. 13 such that the posterior direction extends into the page in the anterior direction extends out of the page. Here an example embodiment of implant 102 is shown positioned within prostatic urethra 1306. Implant 102 is generally positioned centrally within prostatic urethra 1306 as viewed from this perspective, in other words, generally an equal distance from the superior and inferior edges of prostate gland 1302. Placement of implant 102 is generally at the discretion of the medical professional and can be offset either superiorly or inferiorly from the positions shown here, however a position within the prostatic urethra 1306 is generally preferred.

[0123] FIG. 14B depicts the area of prostate gland 1302 from generally the same perspective as that of FIG. 13, but with more detail. Here, prostate gland 1302 is in an enlarged state with a median lobe 1402 that protrudes into prostatic urethra 1306. FIG. 14C is a cross-section taken along line 14C-14C of FIG. 14B and shows the slit-like nature of prostatic urethra 1306 in this enlarged prostate gland 1302 where the width of urethra 1306 widens as it progresses from the anterior to the posterior side.

[0124] FIG. 14D depicts an example embodiment of a posteriorly placed implant 102 within the example anatomy described with respect to FIG. 14B and FIG. 14E is a cross-section taken along line 14E-14E of FIG. 14D. As can be seen here, implant 102 is placed generally along the posterior most surface of the prostatic urethra 1306. Implant 102 is sized to have a maximum

2019271283 23 Jan 2025

diameter that is less than the width of prostatic urethra 1306 at its maximum central width (e.g., less than 50% of the width, less than 65% of the width, less than 80% of the width, etc.) such that implant 102 can be described as residing substantially on the posterior side of prostatic urethra 1306, and not in contact with the anterior most side of urethra 1306. The implications of this placement are shown in FIG. 14E where the opening through prostate gland 1302 that is created by implant 102 is positioned primarily on the posterior side of prostate gland 1302 and urethra 1306.

[0125] FIG. 14F depicts an example embodiment of an anteriorly placed implant 102 within the example anatomy described with respect to FIG. 14B and FIG. 14G is a cross-section taken along line 14G-14G of FIG. 14E. As can be seen here, implant 102 is placed generally along the anterior most surface of prostatic urethra 1306. Implant 102 can be sized to have a maximum diameter that is less than the width of prostatic urethra 1306 at its maximum central width (e.g., less than 50% of the width, less than 65% of the width, less than 80% of the width, etc.) such that implant 102 can be described as residing substantially on the anterior side of prostatic urethra 1306, and not in contact with the posterior most side of urethra 1306. The implications of this placement are shown in FIG. 14G where the opening through prostate gland 1302 that is created by implant 102 is positioned primarily on the anterior side of prostate gland 1302 and urethra 1306. With both the posterior placement and the anterior placement, implant 102 can still be placed generally centrally with respect to prostate gland 1302 as shown in FIG. 14A.

Deployment of implant 102 in a posterior or anterior position is generally at the discretion of the medical professional. Other variations of placement can also be used including placements that are centrally located between the posterior most side and interior most side of urethra 1306, as well as variations in sizing such that implant 102 has a relatively larger or smaller diameter with respect to prostate 1302 than shown here.

[0126] The embodiments described herein are restated and expanded upon in the following paragraphs without explicit reference to the figures. In many example embodiments, a system for delivering an implantable device is provided, where the system includes a delivery device including: an outer tubular member; an inner tubular member having a first inner lumen and a second inner lumen, the inner tubular member being slidable within the outer tubular member, where the first inner lumen is adapted to house an elongate grasper member configured to releasably couple with a proximal portion of an implant; and a distal control member slidable

2019271283 23 Jan 2025

within the second inner lumen, where the distal control member includes a retainer configured to releasably couple with a distal portion of the implant.

[0127] In some embodiments, the implant is configured to maintain a prostatic urethra in an at least partially open state. In some embodiments, the implant has a body including first and second ring-shaped structures and an interconnect that extends between the first and second ring-shaped structures. The body of the implant can be only a single wire. The implant can include a distal engagement member configured to releasably couple with the retainer and/or a proximal engagement member configured to releasably couple with the elongate grasper member. In some embodiments, the implant includes a wire-like distal engagement member that extends proximally away from a distal-most portion of the implant and/or a wire-like proximal engagement member. In some embodiments, the first ring-shaped structure can be the distal-most ring-shaped structure of the implant and has a relatively smaller width than the second ring-shaped structure.

[0128] In some embodiments, the inner tubular member is slidable and rotatable with respect to the distal control member while the retainer is releasably coupled with the distal portion of the implant. The system can further include an elongate member coupled with the retainer and having a proximal end that is manipulatable by a user to permit release of the distal portion of the implant from the retainer. In some embodiments, the retainer is tubular and adapted to slide along the distal control member. The distal control member can include a recess adapted to receive the distal portion of the implant and the retainer can be movable to uncover the recess while the distal portion of the implant is received within the recess. In some embodiments the retainer includes a slot through which the implant can pass.

[0129] In some embodiments, the system includes an elongate anchor member. The elongate anchor member can include an anchor configured to contact a bladder wall. The anchor can be an inflatable balloon or multiple inflatable balloons. In some embodiments, the elongate anchor member includes a wire-form member having a portion configured to automatically deflect when deployed.

[0130] In some embodiments, the elongate grasper member includes a recess configured to releasably couple with the proximal portion of an implant. In some embodiments, the system is configured such that the proximal portion of the implant is free to release from the recess of the elongate grasper member when the recess is unconstrained by the first inner lumen.

2019271283 23 Jan 2025

[0131] In some embodiments, a proximal control device is included and coupled with a proximal end region of the delivery device. The proximal control device can be manipulatable by a user to control deployment of the implant from the delivery device. In some embodiments, the proximal control device includes a housing and is configured to distally advance the elongate grasper member with respect to the housing and the inner tubular member, and/or is configured to proximally retract and rotate the inner tubular member with respect to the housing and the distal control member, and/or is configured to proximally retract the outer tubular member with respect to the housing.

[0132] In some embodiments, the proximal control device includes: a user actuator; a first gear assembly coupled with the user actuator; a cam assembly coupled with the first gear assembly; and a second gear assembly coupled with the cam assembly. In some embodiments, the first gear assembly is configured to control longitudinal movement of the elongate grasper member, the cam assembly is configured to control longitudinal movement of the inner tubular member, and/or the second gear assembly is configured to control rotation of the inner tubular member.

[0133] In many embodiments, a system for delivering an implantable device is provided, where the system includes: a delivery device including a first elongate member having an inner lumen, an elongate grasper member slidable within the inner lumen and configured to hold a proximal portion of an implant, and a distal control member configured to hold a distal portion of the implant; and a proximal control device coupled with a proximal end region of the delivery device, the proximal control device including a user actuator and a housing.

[0134] In some embodiments, the proximal control device includes a first gear assembly within the housing, the proximal control device being configured to translate movement of the user actuator into movement in the first gear assembly. In some embodiments, the proximal control device includes a switch that selects between movement of the first gear assembly in a first direction and movement of the first gear assembly in a second direction. In some embodiments, the user actuator is coupled with a yoke that is coupled with a first pawl and a second pawl. The switch selectively can engage either the first pawl or the second pawl with a pinion gear. The proximal control device can be configured such that rotation of the pinion gear causes rotation of a face gear. The proximal control device can be configured such that rotation of the face gear causes rotation of a reel coupled with the elongate grasper member.

2019271283 23 Jan 2025

[0135] In some embodiments, the system further includes an input gear engaged with the face gear and a reel gear engaged with the input gear, the reel gear being coupled with or integrated with the reel. In some embodiments, the input gear is an interrupted gear, and rotation of the reel gear by the input gear causes rotation of the reel and longitudinal movement of the elongate grasper member. In some embodiments, movement of the first gear assembly in the first direction causes distal movement of the elongate grasper member, and movement of the first gear assembly in the second direction causes proximal movement of the elongate grasper member.

[0136] In some embodiments, the proximal control device includes a cam assembly within the housing, the proximal control device being configured to translate movement of the user actuator into movement in the cam assembly. The cam assembly can be coupled with the first elongate member and can be configured to move the first elongate member proximally with respect to the housing. In some embodiments, the cam assembly includes a rotatable cam having a slot, the first elongate member being coupled with a guide member received within the slot. In some embodiments, the slot includes a sloped slot portion and a radial slot portion. The cam assembly can include an inner tube having a longitudinal slot with the guide member received in the longitudinal slot.

[0137] In some embodiments, the first gear assembly includes a face gear having a first set of teeth that engage with teeth of another gear in the first gear assembly, where the face gear is coupled with the cam assembly such that movement of the face gear causes movement in the cam assembly.

[0138] In some embodiments, the proximal control device includes a second gear assembly and movement in the cam assembly can cause movement in the second gear assembly. The second gear assembly can be coupled with the first elongate member and can be configured to rotate the first elongate member with respect to the housing. The second gear assembly can include a central gear having an aperture configured to receive the first elongate member such that rotation of the central gear causes rotation of the first elongate member. In some embodiments, the second gear assembly includes an annular gear coupled with the cam assembly and coupled with the central gear by way of a planetary gear assembly. The annular gear can engage the planetary gear assembly such that rotation of the annular gear in a first direction causes first directional rotation of the central gear and rotation of the annular gear in a second direction causes second

2019271283 23 Jan 2025

directional rotation of the central gear, the first directional rotation of the central gear being opposite to the second directional rotation.

[0139] In some embodiments, the proximal control device includes a releasable lock mechanism that prevents the proximal portion of the implant held by the elongate grasper member from exiting the inner lumen. In some embodiments, the lock mechanism includes a movable tracking mechanism that interfaces with a groove in a face gear of the first gear assembly, the proximal control device configured such that movement of the face gear moves the tracking mechanism as the implant exits the inner lumen. The proximal control device can be configured such that the tracking mechanism is prevented from further motion prior to the proximal portion of the implant exiting the inner lumen.

[0140] In some embodiments, the proximal control device includes a release structure configured to be actuated by a user, where the release structure is configured to disengage the tracking mechanism from the face gear to allow the proximal portion of the implant to exit the inner lumen. The release structure can be a pull tab and can be coupled with the elongate grasper member.

[0141] In many embodiments, a method of delivering an implant is provided that includes: advancing a delivery device within a body lumen of a patient, where the delivery device includes as first tubular member housing an implant, a distal control member slidable within the first tubular member and releasably coupled with a distal portion of the implant, and an elongate grasper member slidable within the first tubular member and releasably coupled with a proximal portion of the implant; causing relative motion between the elongate grasper member and the first tubular member to expose at least a portion of the implant from within the first tubular member; and releasing the distal portion of the implant from the distal control member and the proximal portion of the implant from the elongate grasper member.

[0142] In some embodiments, the body lumen is a prostatic urethra of a human. In some embodiments, upon release of the distal portion and the proximal portion, the implant is released from the delivery device in a state adapted to maintain the prostatic urethra in an at least partially open state.

[0143] In some embodiments, the implant has a body including first and second ring-shaped structures and an interconnect that extends between the first and second ring-shaped structures and causing relative motion can include distally advancing the elongate grasper member. In

2019271283 23 Jan 2025

some embodiments, the method further includes rotating the first tubular member in a first direction with respect to the distal control member during exposure of the first ring-shaped structure from the first tubular member. In some embodiments, the method further includes rotating the first tubular member in a second direction with respect to the distal control member during exposure of the second ring-shaped structure from the first tubular member, the second direction being opposite the first direction. Rotation of the first tubular member in the first and second directions can occur while the distal control member is releasably coupled with the distal portion of the implant.

[0144] In some embodiments, the method further includes proximally retracting the first tubular member with respect to the elongate grasper member and the distal control member to expose the interconnect from the first tubular member. In some embodiments, the method further includes rotating the first tubular member while proximally retracting the first tubular member. In these embodiments, the interconnect can be curved.

[0145] In some embodiments, a retainer couples the distal portion of the implant to the distal control member, and the method includes releasing the retainer to release the distal portion of the implant from the distal control member.

[0146] In some embodiments, the method further includes exposing the proximal portion of the implant from within the first tubular member to release the proximal portion of the implant from the elongate grasper member.

[0147] In some embodiments, the method further includes anchoring the delivery device against a wall of a bladder before causing relative motion between the elongate grasper member and the first tubular member. In some embodiments, anchoring the delivery device includes inflating a balloon in the bladder.

[0148] In some embodiments, a proximal control device is coupled with a proximal end region of the delivery device, and the method includes moving a user actuator of the proximal control device by the user, where moving the user actuator causes motion in a first gear assembly of the proximal control device. In some embodiments, the first gear assembly causes the elongate grasper member to distally advance with respect to the first tubular member. In some embodiments, the first gear assembly causes movement in a cam assembly and a second gear assembly. In some embodiments, movement in the cam assembly causes intermittent retraction of the first tubular member with respect to the distal control member. In some embodiments,

2019271283 23 Jan 2025

movement in the second gear assembly causes intermittent rotation of the first tubular member with respect to the distal control member.

[0149] In some embodiments, the user actuator is a first user actuator, and the method includes actuating a second user actuator of the proximal control device. In some embodiments, actuating the second user actuator unlocks a lock mechanism and permits release of the distal portion of the implant from the distal control member and the proximal portion of the implant from the elongate grasper member. In some embodiments, actuating the second user actuator removes a retainer from the distal portion of the implant and rotates the distal control member to cause the distal portion of the implant to disengage from the distal control member.

[0150] In some embodiments, the first tubular member is an inner tubular member slidably received within an outer tubular member of the delivery device.

[0151] In many embodiments, a system for delivering an implant is provided, where the system includes a delivery device including: an outer tubular member including an imaging device located in a distal end region of the outer tubular member; an inner tubular member being within the outer tubular member, where the inner tubular member is adapted to house at least a portion of an implant; one or more structures slidably advanceable within the inner tubular member to cause deployment of the implant from within the inner tubular member; and a proximal control device coupled with the inner tubular member and the one or more structures, and releasably coupled with the outer tubular member with a coupling mechanism, where the proximal control device is configured to longitudinally move the inner tubular member and the outer tubular member concurrently.

[0152] In some embodiments, the system further includes the implant. The implant can be configured to maintain a prostatic urethra in an at least partially open state. In some embodiments, the implant has a body including first and second ring-shaped structures and an interconnect that extends between the first and second ring-shaped structures.

[0153] In some embodiments, the one or more structures include: an elongate grasper member configured to releasably couple with a proximal portion of the implant; and a distal control member configured to releasably couple with a distal portion of the implant. In some embodiments, the distal control member includes a retainer configured to releasably couple with the distal portion of the implant, where the implant includes a distal engagement member configured to releasably couple with the retainer. In some embodiments, the implant includes a

2019271283 23 Jan 2025

proximal engagement member configured to releasably couple with the elongate grasper member. In some embodiments, the implant includes a wire-like distal engagement member that extends proximally away from a distal-most portion of the implant. In some embodiments, the implant includes a wire-like proximal engagement member.

[0154] In some embodiments, the proximal control device is configured to rotate and longitudinally move the inner tubular member with respect to the distal control member while the distal control member is releasably coupled with the distal portion of the implant. In some embodiments, the proximal control device is configured to rotate the inner tubular member without rotating the outer tubular member.

[0155] In some embodiments, the system further includes an elongate member coupled with the retainer and having a proximal end that is manipulatable by a user to permit release of the distal portion of the implant from the retainer. In some embodiments, the retainer is tubular and adapted to slide along the distal control member. In some embodiments, the distal control member includes a recess adapted to receive the distal portion of the implant. In some embodiments, the retainer is movable to uncover the recess while the distal portion of the implant is received within the recess. In some embodiments, the retainer includes a slot.

[0156] In some embodiments, the system further includes an elongate anchor member. In some embodiments, the elongate anchor member includes an anchor configured to contact a bladder wall. In some embodiments, the anchor is an inflatable balloon. In some embodiments, the elongate anchor member includes multiple balloons. In some embodiments, the elongate anchor member includes a wire-form member having a portion configured to automatically deflect when deployed.

[0157] In some embodiments, the elongate grasper member includes a recess configured to releasably couple with the proximal portion of an implant. In some embodiments, the system is configured such that the proximal portion of the implant is free to release from the recess of the elongate grasper member when the recess is unconstrained by the first inner lumen.

[0158] In some embodiments, the proximal control device includes a first portion including a first housing including a handle, and a second portion including a second housing, the second portion being slidable with respect to the first portion. In some embodiments, the inner tubular member is secured to the first housing, and the outer tubular member is secured to the second housing. In some embodiments, release of the coupling mechanism permits the first portion to

2019271283 23 Jan 2025

be decoupled from the second portion. In some embodiments, the coupling mechanism includes a deflectable member receivable within a groove of a shaft portion of the first portion of the proximal control device.

[0159] In some embodiments, the groove is annular and extends about the periphery of the shaft portion, where the shaft portion is secured to the inner tubular member. In some embodiments, the shaft portion includes multiple grooves, each adapted to receive the deflectable member. In some embodiments, the deflectable member is slidable within the groove, such that the shaft portion is rotatable while the deflectable member is received within the groove.

[0160] In some embodiments, the second portion includes a flexible bus having a first end electrically connected to a printed circuit board within the second portion and a second end electrically connected to the imaging device.

[0161] In some embodiments, the distal end region of the outer tubular member further includes an illumination device.

[0162] In some embodiments, the second portion includes: a first flexible bus having a first end electrically connected to a printed circuit board within the second portion and a second end electrically connected to the imaging device; and a second flexible bus having a first end electrically connected to the printed circuit board within the second portion and a second end electrically connected to the illumination device.

[0163] In some embodiments, a distal end region of the inner tubular member is distal to the distal end region of the outer tubular member by a separation distance, and where the proximal control device is configured to longitudinally move the outer tubular member and inner tubular member concurrently without changing the separation distance.

[0164] In some embodiments, the proximal control device includes: a user actuator; a first gear assembly coupled with the user actuator; a cam assembly coupled with the first gear assembly; and a second gear assembly coupled with the cam assembly. In some embodiments, the first gear assembly is configured to control longitudinal movement of the elongate grasper member, the cam assembly is configured to control longitudinal movement of the inner tubular member, and the second gear assembly is configured to control rotation of the inner tubular member.

[0165] In some embodiments, the implant is sized to fit entirely within a prostatic urethra. In some embodiments, the delivery system is usable to deliver the implant to an anterior position

2019271283 23 Jan 2025

within the prostatic urethra. In some embodiments, the delivery system is usable to deliver the implant to a posterior position within the prostatic urethra.

[0166] In many embodiments, a method of imaging delivery of an implant is provided, the method including: advancing a delivery device within a urethra of a patient, where the delivery device includes an outer tubular member including an imaging device located in a distal end region of the outer tubular member, an inner tubular member within the outer tubular member and housing at least a portion of an implant, and one or more structures slidably advanceable within the inner tubular member to cause deployment of the implant from within the inner tubular member, where the outer tubular member, inner tubular member, and one or more structures are each coupled with a proximal control device outside of the patient; longitudinally retracting the inner tubular member with respect to the proximal control device and the one or more structures to at least partially deploy the implant from the inner tubular member; and while the inner tubular member is being longitudinally retracted, concurrently (a) longitudinally retracting the outer tubular member with respect to the proximal control device and (b) imaging the at least partially deployed implant with an imaging device located at a distal end region of the outer tubular member. In some embodiments, the urethra is the prostatic urethra.

[0167] In some embodiments, the method further includes releasing the implant from the delivery device. In some embodiments, the method further includes releasing the implant from the delivery device such that the implant is entirely within the prostatic urethra.

[0168] In some embodiments, the implant is released while in an expanded state, the diameter of the implant in the expanded state being less than the smallest width of the prostatic urethra where the implant is released.

[0169] In some embodiments, the implant is released such that the implant contacts the posterior most tissue surface of the prostatic urethra. In some embodiments, the implant is released such that the implant does not contact the anterior most tissue surface of the prostatic urethra.

[0170] In some embodiments, the implant is released such that the implant contacts the anterior most tissue surface of the prostatic urethra. In some embodiments, the implant is released such that the implant does not contact the posterior most tissue surface of the prostatic urethra.

[0171] In some embodiments, the outer tubular member is longitudinally retracted at the same rate as the inner tubular member.

2019271283 23 Jan 2025

[0172] In some embodiments, the method further includes: rotating the inner tubular member with respect to the proximal control device to at least partially deploy the implant from the inner tubular member; and while the inner tubular member is being rotated, concurrently (a) maintaining the outer tubular member in a rotationally fixed position with respect to the proximal control device and (b) imaging the at least partially deployed implant with the imaging device.

[0173] In some embodiments, the method further includes the following steps performed prior to advancing the delivery device within the urethra of the patient: inserting the inner tubular member into the outer tubular member, where the inner tubular member is coupled with a first portion of the proximal control device and the outer tubular member is coupled with a second portion of the proximal control device; and coupling the first portion of the proximal control device to the second portion of the proximal control device. In some embodiments, coupling the first portion of the proximal control device to the second portion of the proximal control device includes coupling a deflectable member of the second portion to a groove of the first portion.

[0174] In some embodiments, the method further includes illuminating the implant with an illumination device at the distal end region of the outer tubular member.

[0175] In many embodiments, a method of user assembly of a proximal control device is provided, the method including: inserting an inner tubular member into an outer tubular member, where the inner tubular member is coupled with a first portion of a proximal control device and the outer tubular member is coupled with a second portion of the proximal control device; and coupling the first portion of the proximal control device to the second portion of the proximal control device with a coupling mechanism, where the inner tubular member is longitudinally and rotationally movable with respect to the first portion of the proximal control device, where the first portion is coupled to the second portion such that longitudinal movement of the inner tubular member causes longitudinal movement of the second portion and outer tubular member, and where the first portion is coupled to the second portion such that rotational movement of the inner tubular member does not cause rotational movement of the second portion and outer tubular member.

[0176] In some embodiments, the first portion can couple to the second portion in more than one position, and the method includes: coupling the first portion of the proximal control device to the second portion of the proximal control device with the coupling mechanism in a first position; uncoupling the first portion of the proximal control device from the second portion of the

2019271283 23 Jan 2025

proximal control device; and coupling the first portion of the proximal control device to the second portion of the proximal control device with the coupling mechanism in a second position. [0177] In some embodiments, the first position corresponds to a first distance between a distal terminus of the inner tubular member and a distal terminus of the outer tubular member, and the second position corresponds to a second distance between the distal terminus of the inner tubular member and the distal terminus of the outer tubular member, where the first and second distances are different. In some embodiments, the second distance is greater than the first distance and corresponds to a relatively wider field of imaging for the second position as compared to the first position.

[0178] In many embodiments, a method of delivering an implant is provided, the method including: advancing a delivery device within a urethra of a patient; deploying an implant from the delivery device to a position entirely within a prostatic urethra of the patient, where the implant transitions from a unexpanded state to an expanded state upon deployment; and removing the delivery device from the patient while the implant remains in the prostatic urethra in the expanded state that maintains a pathway through the prostatic urethra, the diameter of the implant in the expanded state being less than the smallest width of the prostatic urethra adjacent the implant, where, after removal of the delivery device, the implant contacts the posterior most tissue surface of the prostatic urethra.

[0179] In some embodiments, after removal of the delivery device, the implant contacts the posterior most tissue surface of the prostatic urethra and does not contact the anterior most tissue surface of the prostatic urethra.

[0180] In many embodiments, a method of delivering an implant is provided, the method including: advancing a delivery device within a urethra of a patient; deploying an implant from the delivery device to a position entirely within a prostatic urethra of the patient, where the implant transitions from a unexpanded state to an expanded state upon deployment; and removing the delivery device from the patient while the implant remains in the prostatic urethra in the expanded state that maintains a pathway through the prostatic urethra, the diameter of the implant in the expanded state being less than the smallest width of the prostatic urethra adjacent the implant, where, after removal of the delivery device, the implant contacts the anterior most tissue surface of the prostatic urethra.

2019271283 23 Jan 2025

[0181] In some embodiments, after removal of the delivery device, the implant contacts the anterior most tissue surface of the prostatic urethra and does not contact the posterior most tissue surface of the prostatic urethra.

[0182] All features, elements, components, functions, and steps described with respect to any embodiment provided herein are intended to be freely combinable and substitutable with those from any other embodiment. If a certain feature, element, component, function, or step is described with respect to only one embodiment, then it should be understood that that feature, element, component, function, or step can be used with every other embodiment described herein unless explicitly stated otherwise. This paragraph therefore serves as antecedent basis and written support for the introduction of claims, at any time, that combine features, elements, components, functions, and steps from different embodiments, or that substitute features, elements, components, functions, and steps from one embodiment with those of another, even if the following description does not explicitly state, in a particular instance, that such combinations or substitutions are possible. It is explicitly acknowledged that express recitation of every possible combination and substitution is overly burdensome, especially given that the permissibility of each and every such combination and substitution will be readily recognized by those of ordinary skill in the art.

[0183] As used herein and in the appended claims, the singular forms “a,” “an,” and “the” include plural referents unless the context clearly dictates otherwise.

[0184] The term "comprising" as used in this specification and claims means "consisting at least in part of". When interpreting statements in this specification and claims which include the term "comprising", other features besides the features prefaced by this term in each statement can also be present. Related terms such as "comprise" and "comprised" are to be interpreted in a similar manner.

[0185] While the embodiments are susceptible to various modifications and alternative forms, specific examples thereof have been shown in the drawings and are herein described in detail. It should be understood, however, that these embodiments are not to be limited to the particular form disclosed, but to the contrary, these embodiments are to cover all modifications, equivalents, and alternatives falling within the spirit of the disclosure. Furthermore, any features, functions, steps, or elements of the embodiments may be recited in or added to the

2019271283 23 Jan 2025

claims, as well as negative limitations that define the inventive scope of the claims by features, functions, steps, or elements that are not within that scope.

2019271283 23 Jan 2025

CLAIMS

What is claimed is:

1. A system for delivering an implant, the system comprising a delivery device comprising:
  - an outer tubular member comprising an imaging device located in a distal end region of the outer tubular member;
  - an inner tubular member being within a lumen of the outer tubular member, wherein the inner tubular member is adapted to house at least a portion of an implant, wherein the inner tubular member is configured to slide distally and proximally within the lumen of the outer tubular member;
  - one or more structures slidably advanceable within the inner tubular member to cause deployment of the implant from within the inner tubular member; and
  - a proximal control device coupled with the inner tubular member and the one or more structures, and releasably coupled with the outer tubular member with a coupling mechanism, wherein the proximal control device is configured to longitudinally move the inner tubular member and the outer tubular member concurrently.
2. The system of claim 1, further comprising the implant, wherein the implant is configured to maintain a prostatic urethra in an at least partially open state.
3. The system of claim 2, wherein the implant has a body comprising first and second ring-shaped structures and an interconnect that extends between the first and second ring-shaped structures.
4. The system of claim 2, wherein the one or more structures comprise:
  - an elongate grasper member configured to releasably couple with a proximal portion of the implant; and

2019271283 23 Jan 2025

a distal control member configured to releasably couple with a distal portion of the implant.

5. The system of claim 4, wherein the distal control member comprises a retainer configured to releasably couple with the distal portion of the implant, wherein the implant comprises a distal engagement member configured to releasably couple with the retainer.

6. The system of claim 4, wherein the implant comprises a wire-like distal engagement member that extends proximally away from a distal-most portion of the implant, and/or a wire-like proximal engagement member.

7. The system of claim 4, wherein the proximal control device is configured to rotate and longitudinally move the inner tubular member with respect to the distal control member while the distal control member is releasably coupled with the distal portion of the implant.

8. The system of claim 7, wherein the proximal control device is configured to rotate the inner tubular member without rotating the outer tubular member.

9. The system of claim 5, further comprising an elongate member coupled with the retainer and having a proximal end that is manipulatable by a user to permit release of the distal portion of the implant from the retainer.

10. The system of claim 4, wherein the distal control member comprises a recess adapted to receive the distal portion of the implant.

11. The system of claim 10, wherein the retainer is movable to uncover the recess while the distal portion of the implant is received within the recess.

2019271283 23 Jan 2025

12. The system of claim 1, further comprising an elongate anchor member comprising an anchor configured to contact a bladder wall.

13. The system of claim 12, wherein the anchor is an inflatable balloon.

14. The system of claim 12, wherein the elongate anchor member comprises a wire-form member having a portion configured to automatically deflect when deployed.

15. The system of claim 4, wherein the elongate grasper member comprises a recess configured to releasably couple with the proximal portion of an implant.

16. The system of claim 15, wherein the system is configured such that the proximal portion of the implant is free to release from the recess of the elongate grasper member when the recess is unconstrained by the first inner lumen.

17. The system of claim 1, wherein the proximal control device comprises a first portion comprising a first housing comprising a handle, and a second portion comprising a second housing, the second portion being slidable with respect to the first portion, and wherein the inner tubular member is secured to the first housing, and the outer tubular member is secured to the second housing.

18. The system of claim 17, wherein release of the coupling mechanism permits the first portion to be decoupled from the second portion.

19. The system of claim 1, wherein the distal end region of the outer tubular member further comprises an illumination device.

2019271283 23 Jan 2025

20. The system of claim 1, wherein a distal end region of the inner tubular member is distal to the distal end region of the outer tubular member by a separation distance, and wherein the proximal control device is configured to longitudinally move the outer tubular member and inner tubular member concurrently without changing the separation distance.

21. The system of claim 4, wherein the proximal control device comprises:  
a user actuator;  
a first gear assembly coupled with the user actuator;  
a cam assembly coupled with the first gear assembly; and  
a second gear assembly coupled with the cam assembly, wherein the first gear assembly is configured to control longitudinal movement of the elongate grasper member, the cam assembly is configured to control longitudinal movement of the inner tubular member, and the second gear assembly is configured to control rotation of the inner tubular member.

22. The system of claim 2, wherein the implant is sized to fit entirely within a prostatic urethra, and wherein the delivery system is usable to deliver the implant to an anterior position or a posterior position within the prostatic urethra.

23. A method of imaging delivery of an implant, the method comprising:  
advancing a delivery device within a urethra of a patient, wherein the delivery device comprises an outer tubular member comprising an imaging device located in a distal end region of the outer tubular member, an inner tubular member within a lumen of the outer tubular member and housing at least a portion of an implant, wherein the inner tubular member is configured to slide distally and proximally within the lumen of the outer tubular member, and one or more structures slidably advanceable within the inner tubular member to cause deployment of the implant from within the inner tubular member, wherein the outer tubular

2019271283 23 Jan 2025

member, inner tubular member, and one or more structures are each coupled with a proximal control device outside of the patient;

longitudinally retracting the inner tubular member with respect to the proximal control device and the one or more structures to at least partially deploy the implant from the inner tubular member; and

while the inner tubular member is being longitudinally retracted, concurrently (a) longitudinally retracting the outer tubular member with respect to the proximal control device and (b) imaging the at least partially deployed implant with an imaging device located at a distal end region of the outer tubular member.

24. The method of claim 23, wherein the urethra is the prostatic urethra, the method further comprising releasing the implant from the delivery device such that the implant is entirely within the prostatic urethra.

25. The method of claim 24, wherein the implant is released such that the implant contacts the posterior most tissue surface of the prostatic urethra and/or does not contact the anterior most tissue surface of the prostatic urethra.

26. The method of claim 24, wherein the implant is released such that the implant contacts the anterior most tissue surface of the prostatic urethra and/or does not contact the posterior most tissue surface of the prostatic urethra.

27. The method of claim 24, further comprising:  
rotating the inner tubular member with respect to the proximal control device to at least partially deploy the implant from the inner tubular member; and

2019271283 23 Jan 2025

while the inner tubular member is being rotated, concurrently (a) maintaining the outer tubular member in a rotationally fixed position with respect to the proximal control device and (b) imaging the at least partially deployed implant with the imaging device.

28. The method of claim 23, further comprising the following steps performed prior to advancing the delivery device within the urethra of the patient:

inserting the inner tubular member into the outer tubular member, wherein the inner tubular member is coupled with a first portion of the proximal control device and the outer tubular member is coupled with a second portion of the proximal control device; and

coupling the first portion of the proximal control device to the second portion of the proximal control device.

29. The method of claim 28, wherein coupling the first portion of the proximal control device to the second portion of the proximal control device comprises coupling a deflectable member of the second portion to a groove of the first portion.

30. The method of claim 29, further comprising illuminating the implant with an illumination device at the distal end region of the outer tubular member.

31. A method of user assembly of a proximal control device, comprising:

inserting an inner tubular member into a lumen of an outer tubular member, wherein the inner tubular member is configured to slide distally and proximally within the lumen of the outer tubular member, wherein the inner tubular member is coupled with a first portion of a proximal control device and the outer tubular member is coupled with a second portion of the proximal control device; and

coupling the first portion of the proximal control device to the second portion of the proximal control device with a coupling mechanism,

2019271283 23 Jan 2025

wherein the inner tubular member is longitudinally and rotationally movable with respect to the first portion of the proximal control device,

wherein the first portion is coupled to the second portion such that longitudinal movement of the inner tubular member causes longitudinal movement of the second portion and outer tubular member, and

wherein the first portion is coupled to the second portion such that rotational movement of the inner tubular member does not cause rotational movement of the second portion and outer tubular member.

32. The method of claim 31, wherein the first portion can couple to the second portion in more than one position, the method comprising:

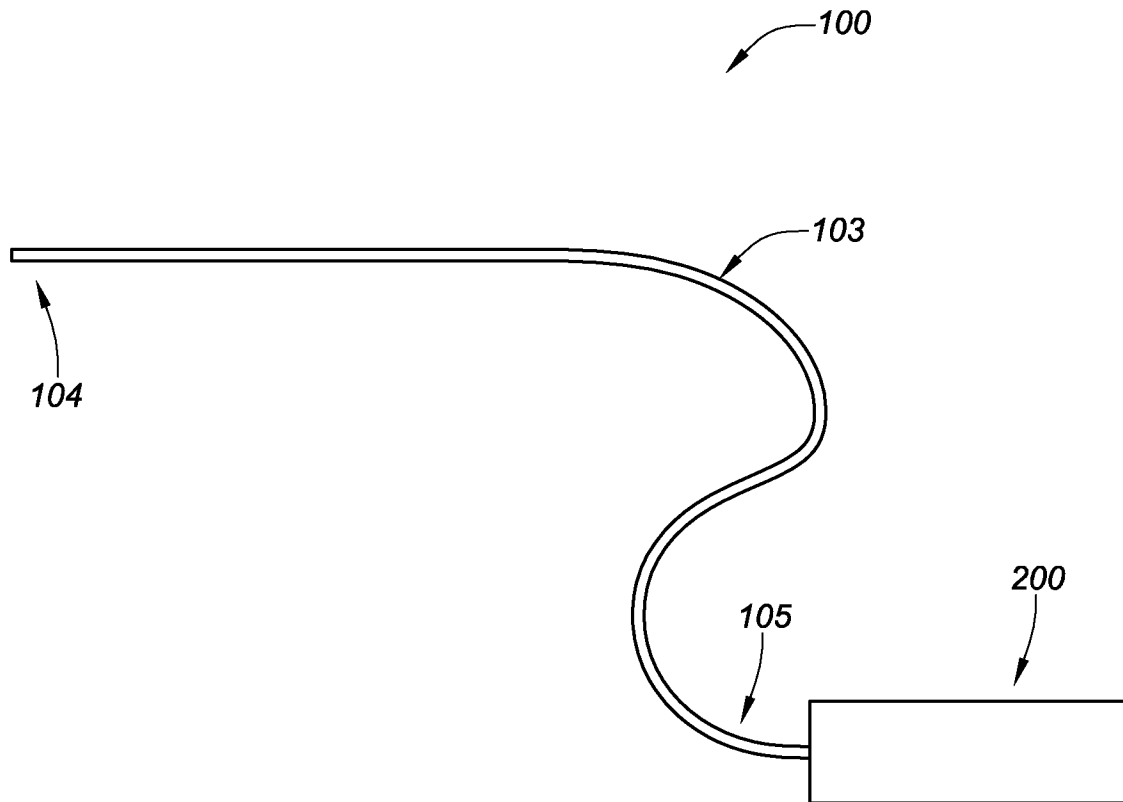
coupling the first portion of the proximal control device to the second portion of the proximal control device with the coupling mechanism in a first position; and

uncoupling the first portion of the proximal control device from the second portion of the proximal control device; and

coupling the first portion of the proximal control device to the second portion of the proximal control device with the coupling mechanism in a second position.

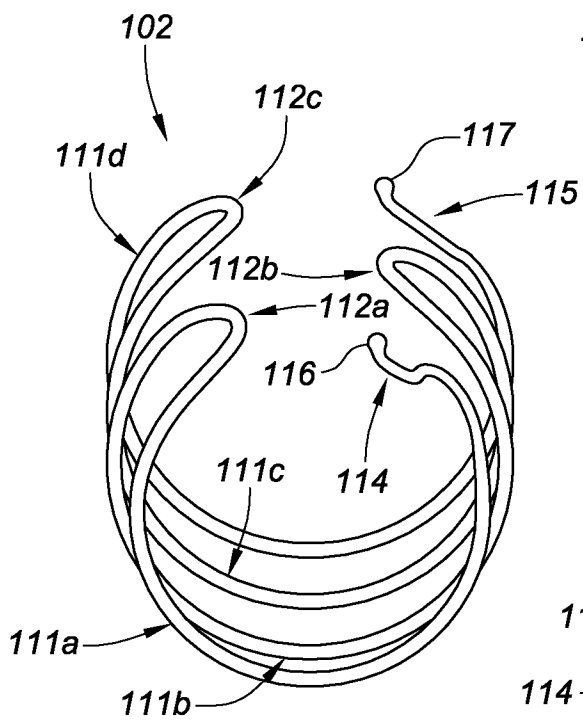
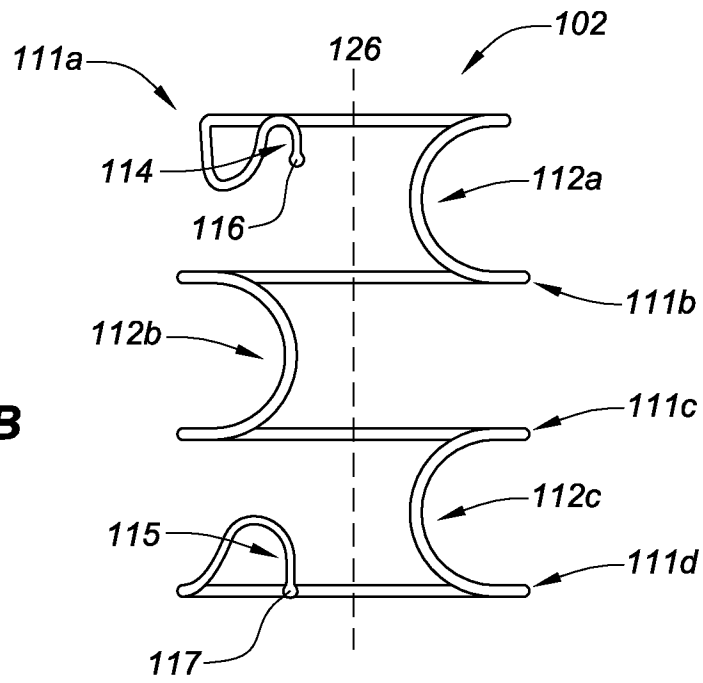
33. The method of claim 32, wherein the first position corresponds to a first distance between a distal terminus of the inner tubular member and a distal terminus of the outer tubular member, and wherein the second position corresponds to a second distance between the distal terminus of the inner tubular member and the distal terminus of the outer tubular member, wherein the first and second distances are different.

34. The method of claim 33, wherein the second distance is greater than the first distance and corresponds to a relatively wider field of imaging for the second position as compared to the first position.

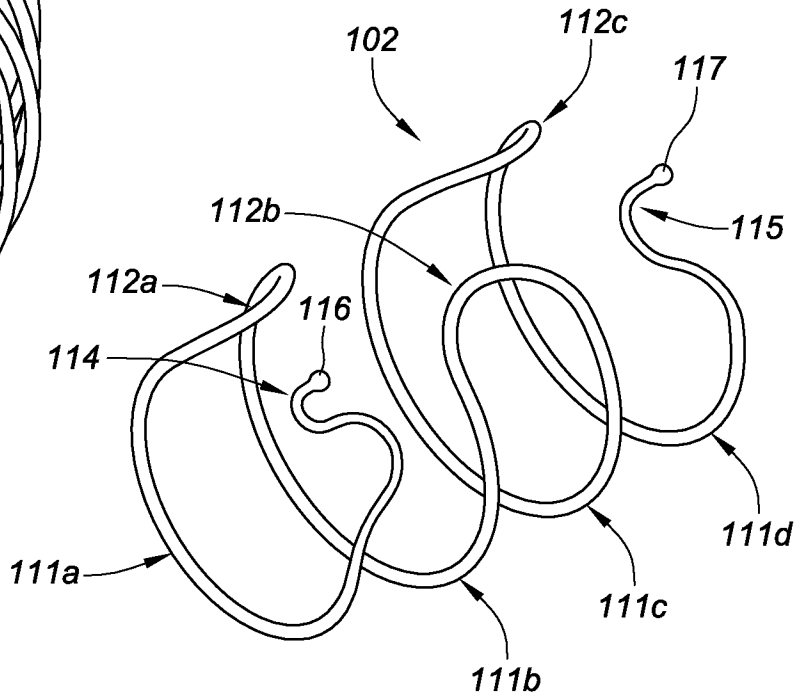


**FIG. 1A**

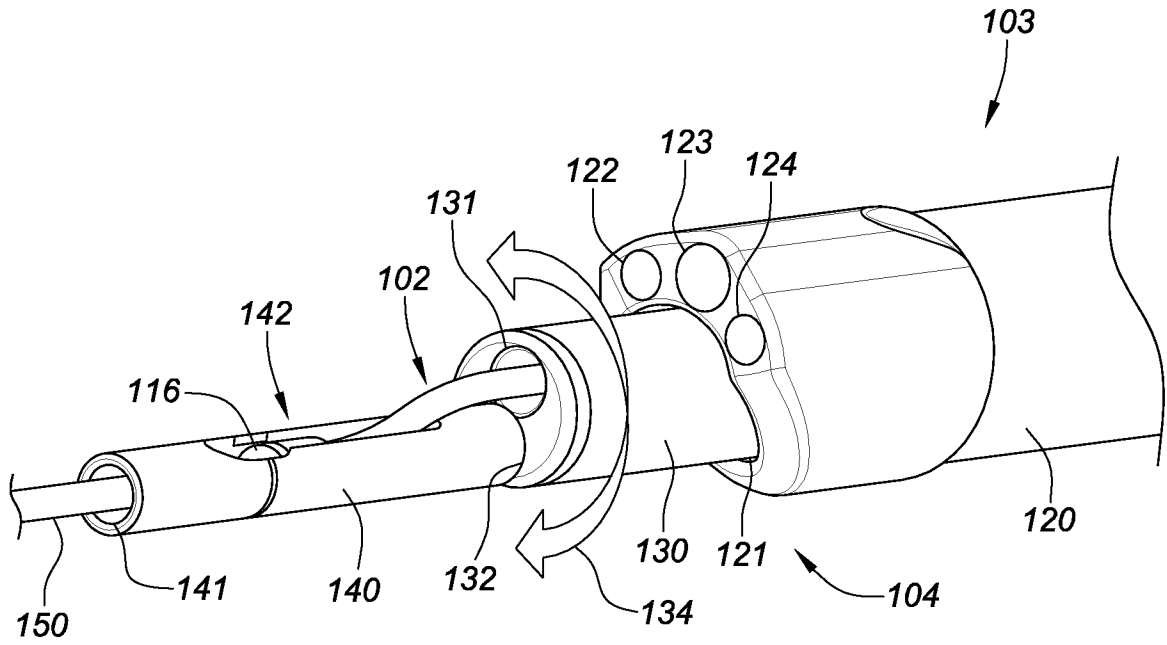
**FIG. 1B**



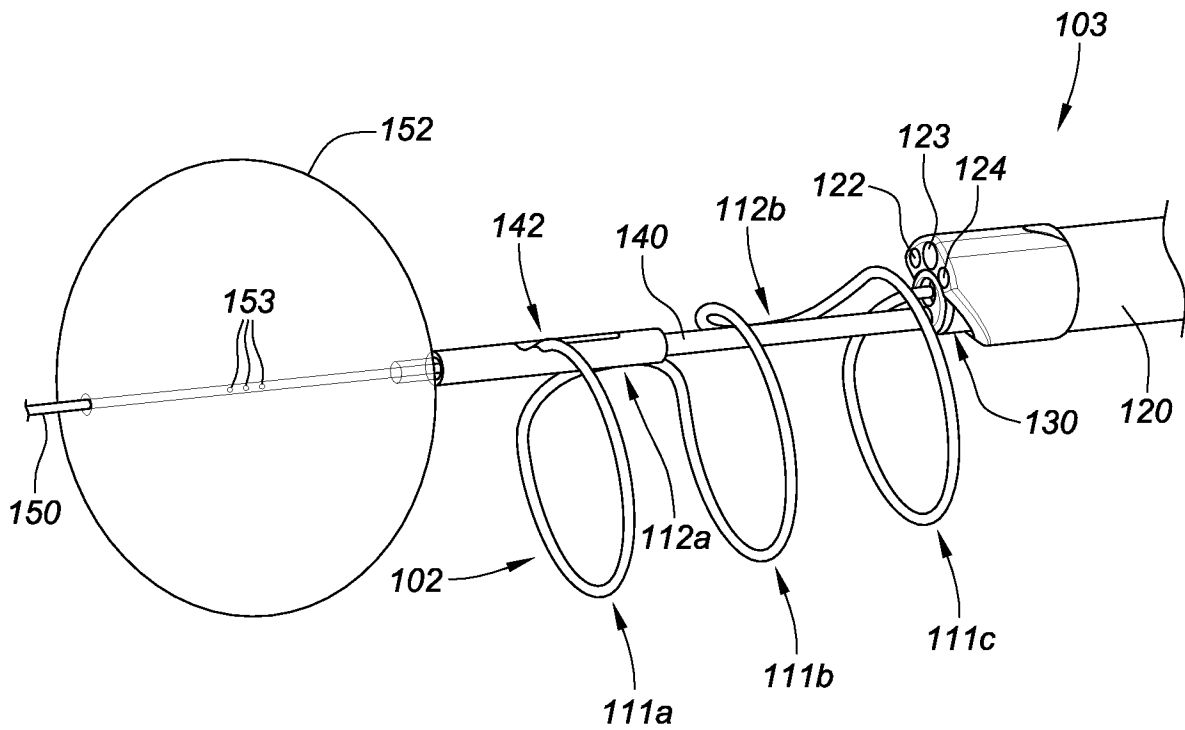
**FIG. 1C**



**FIG. 1D**

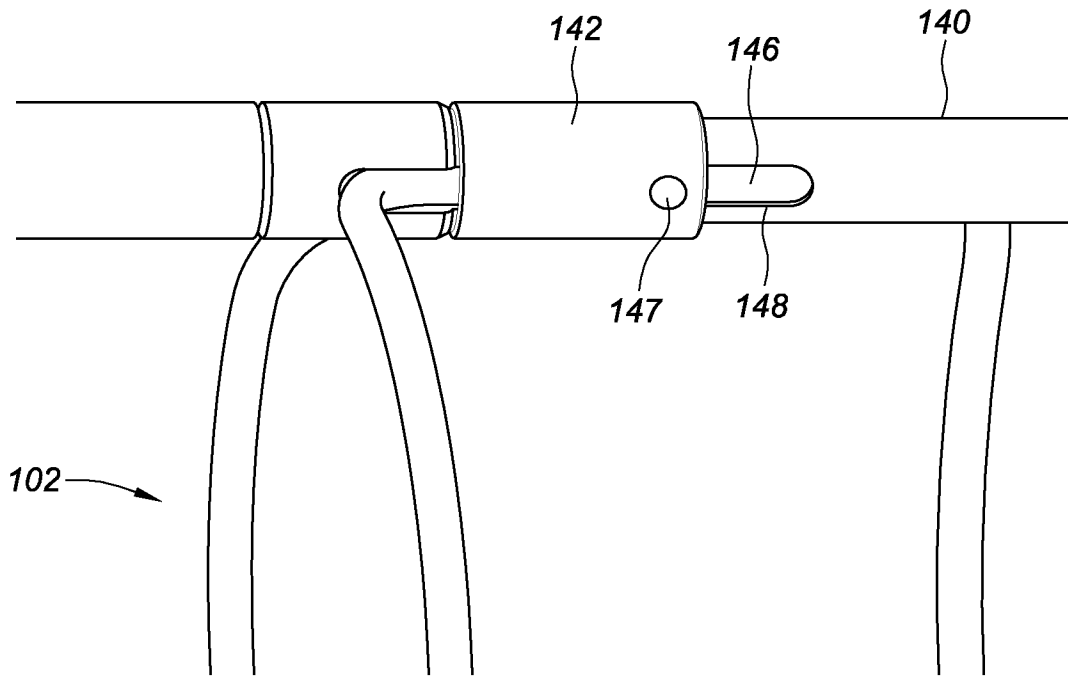


**FIG. 2A**

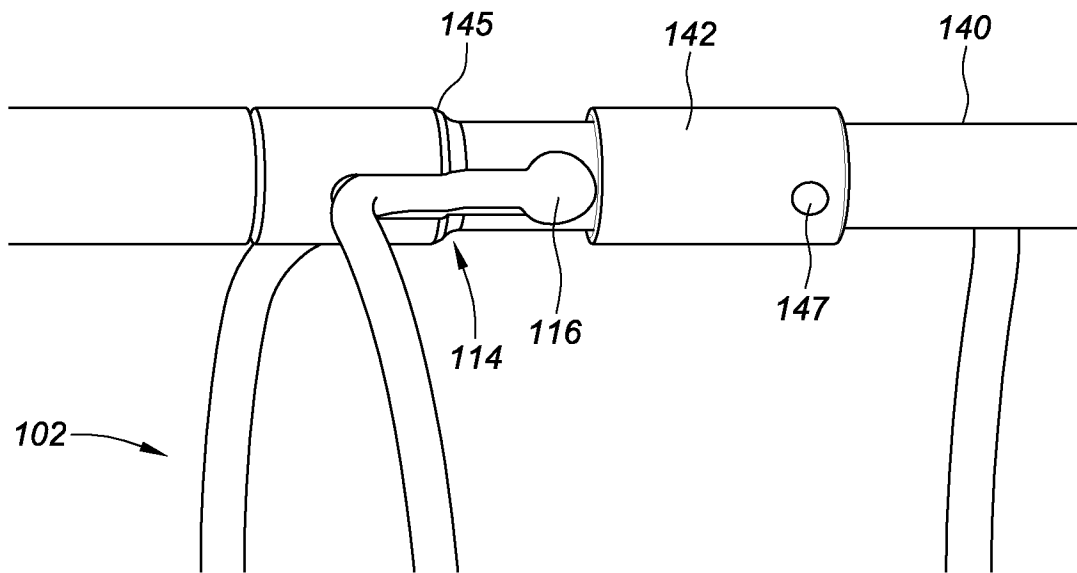


**FIG. 2B**

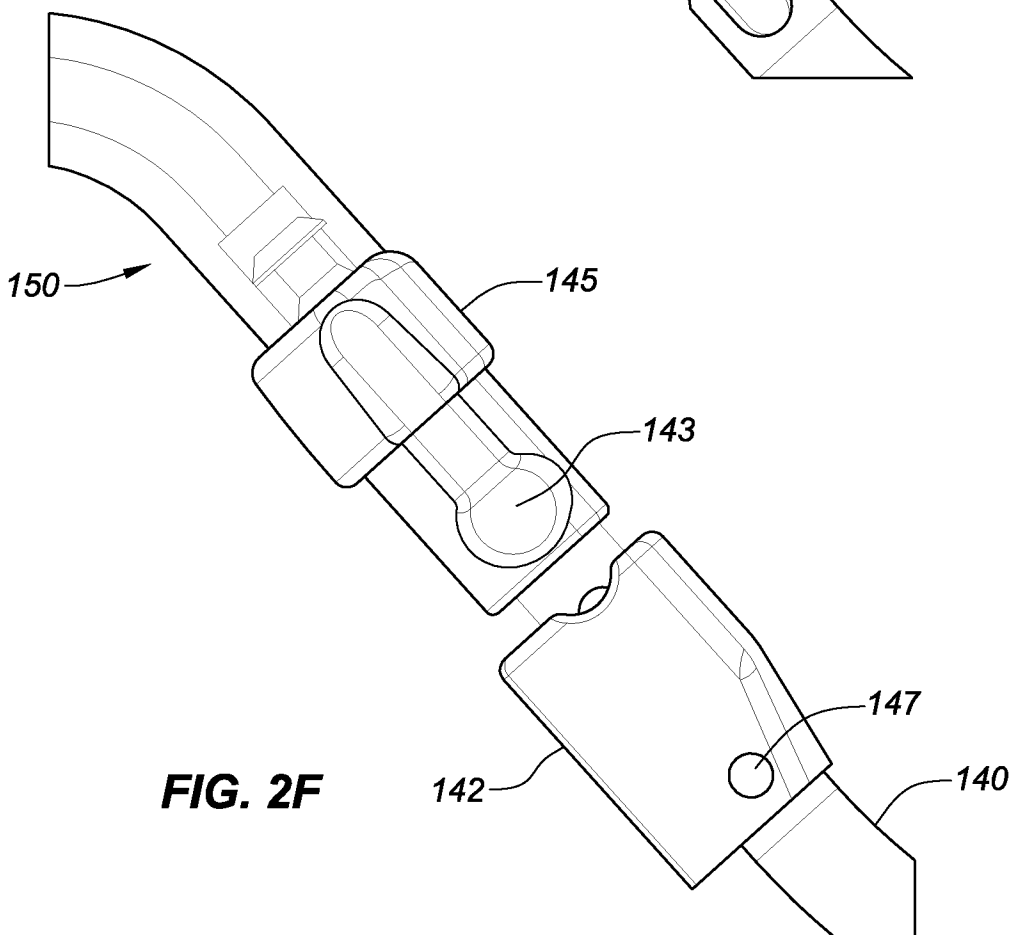
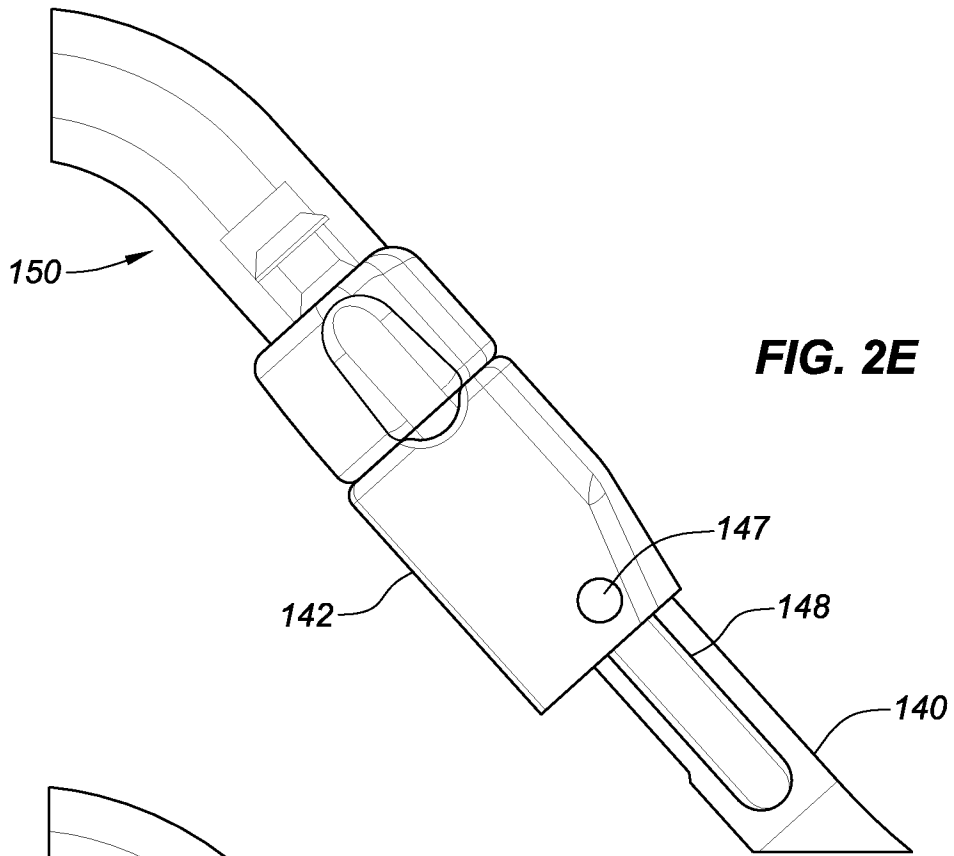
4/36

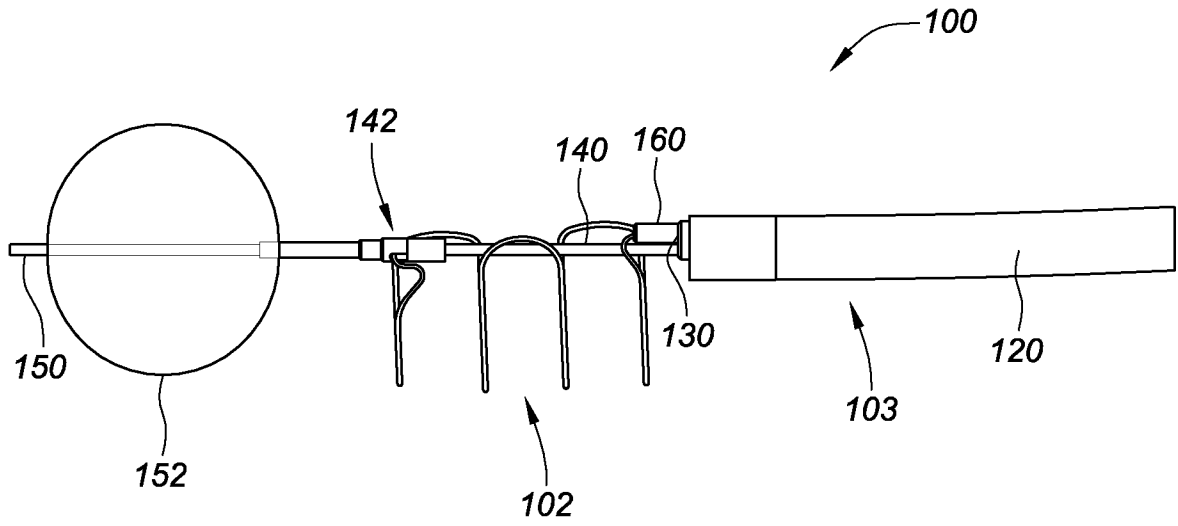


**FIG. 2C**

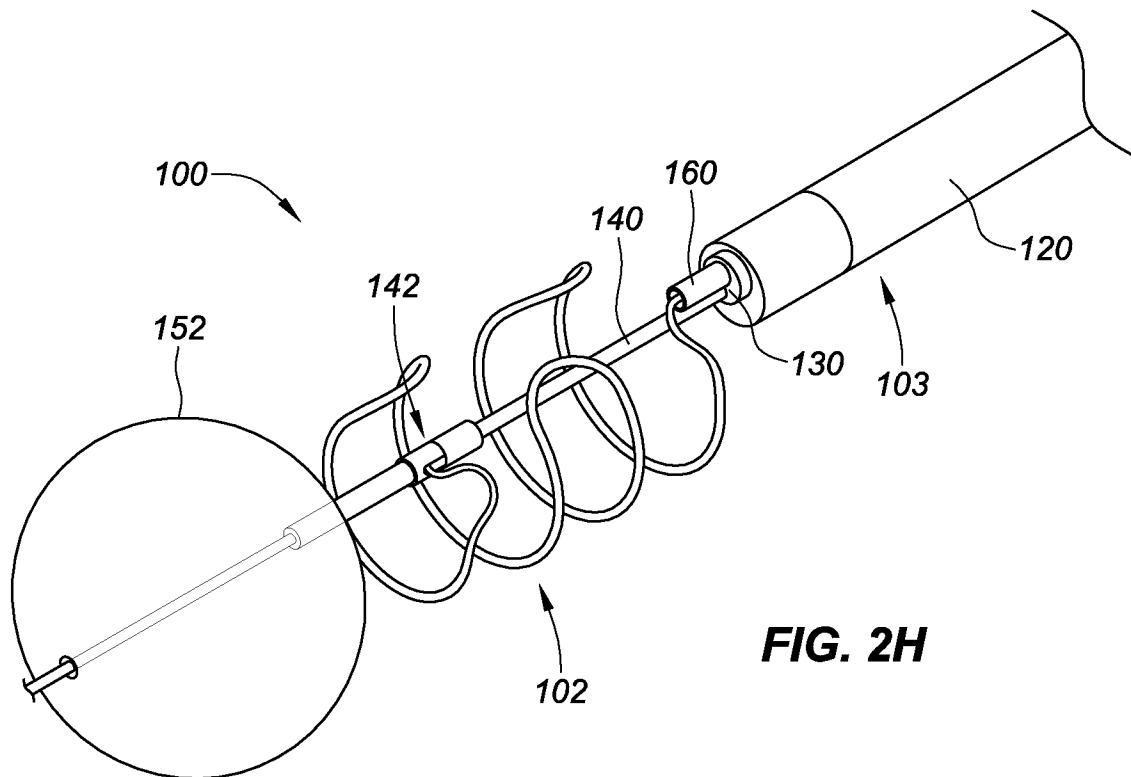


**FIG. 2D**

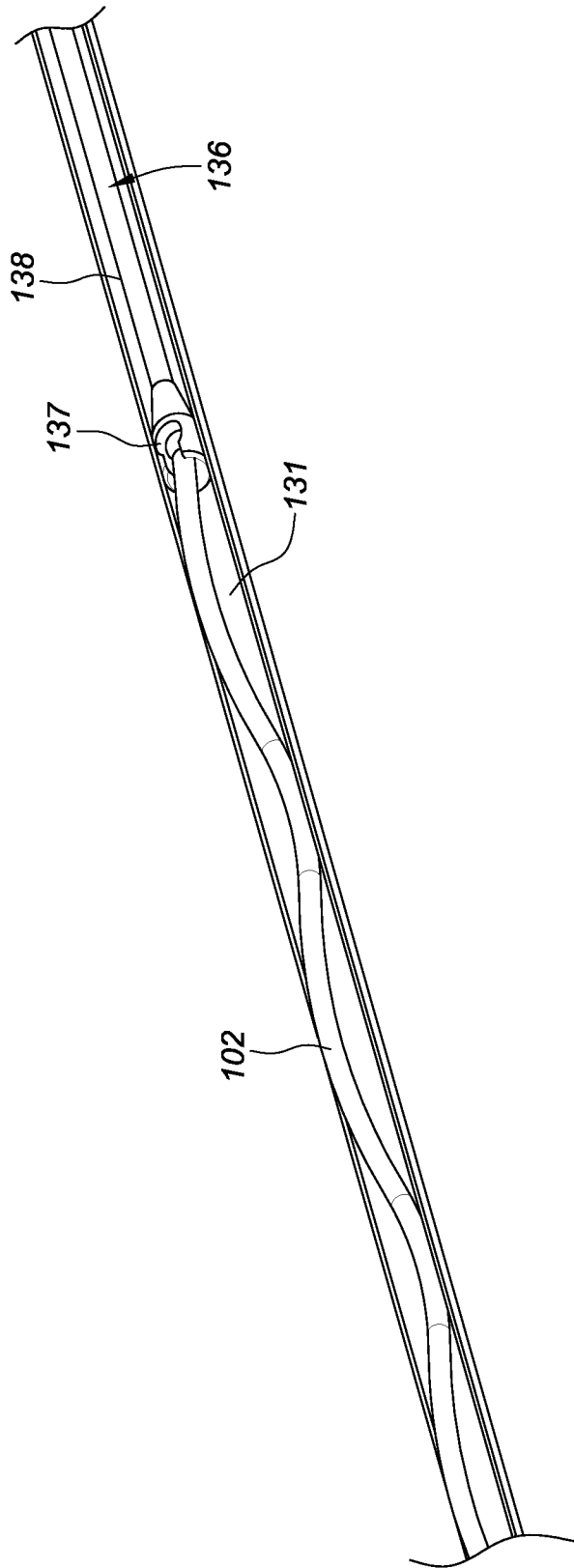




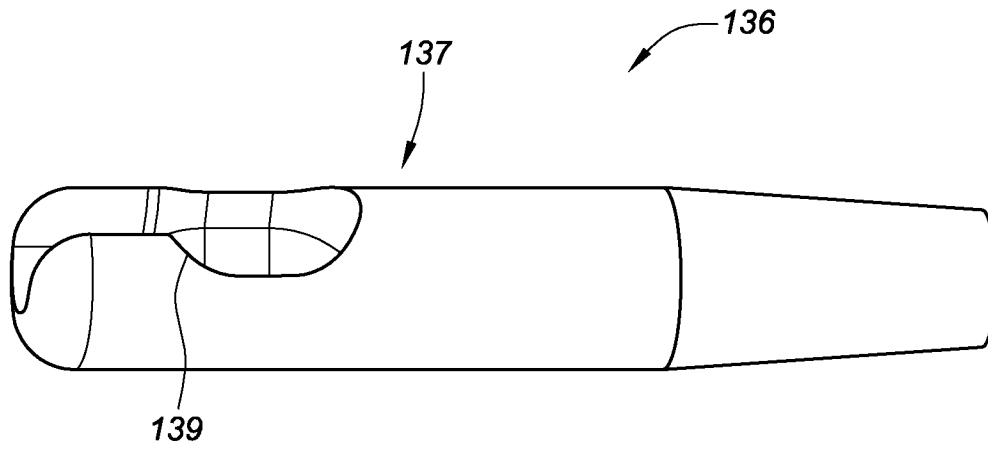
**FIG. 2G**



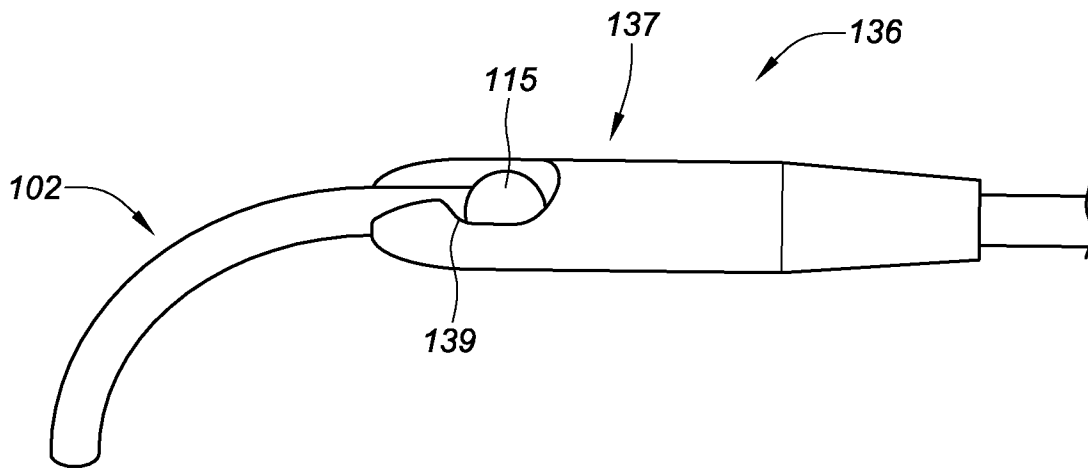
**FIG. 2H**



**FIG. 3A**

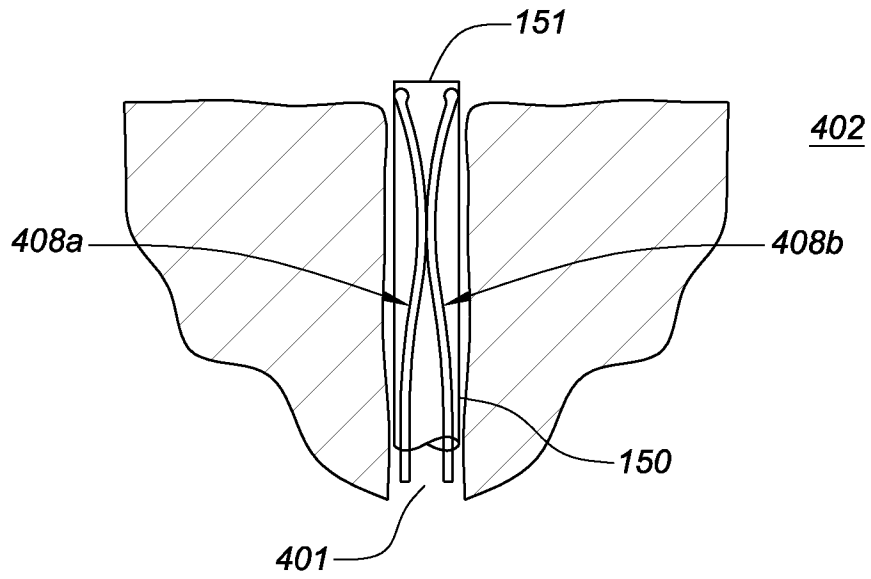


**FIG. 3B**

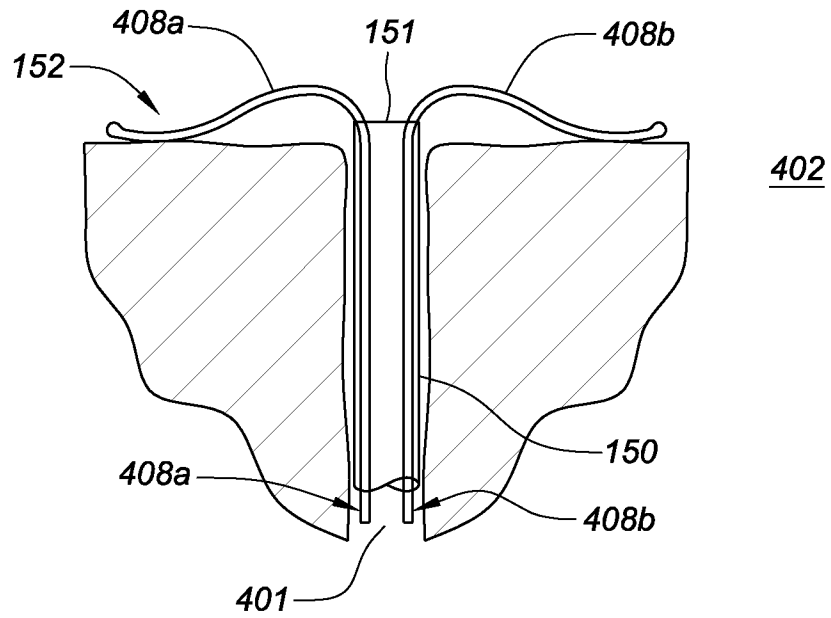


**FIG. 3C**

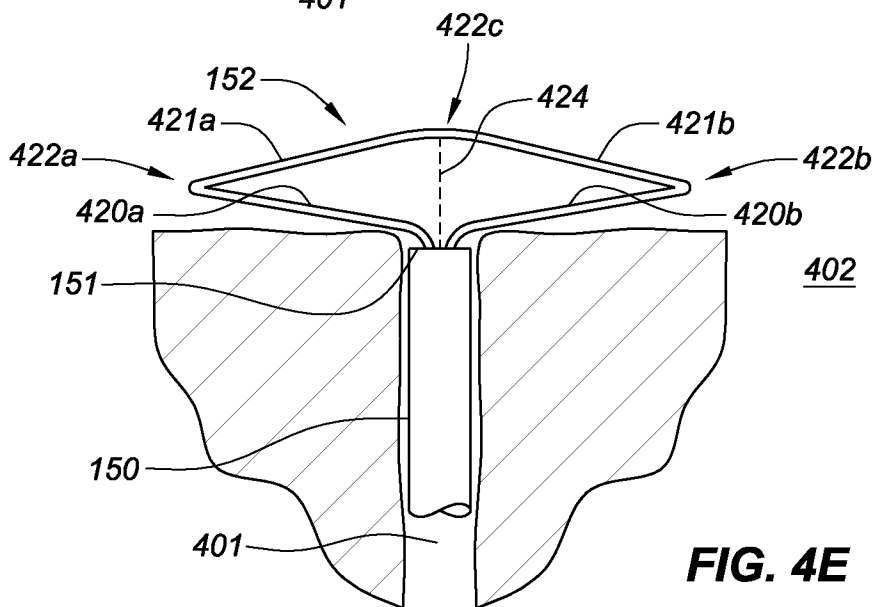
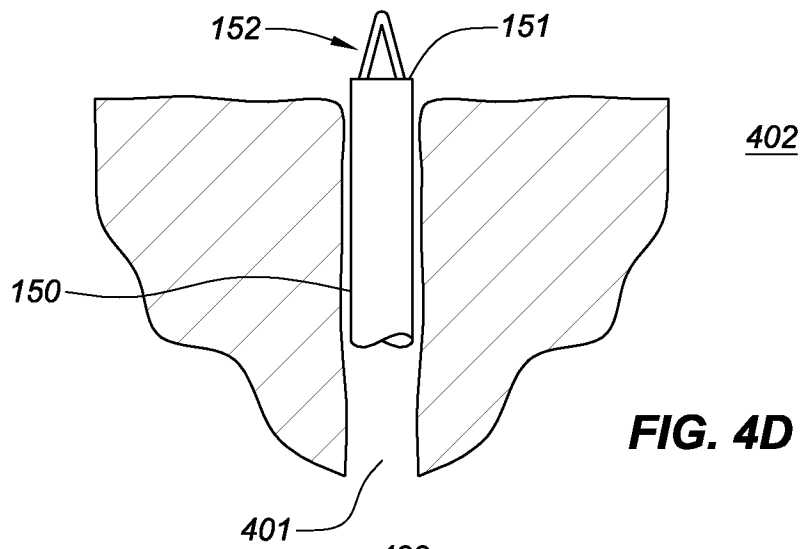
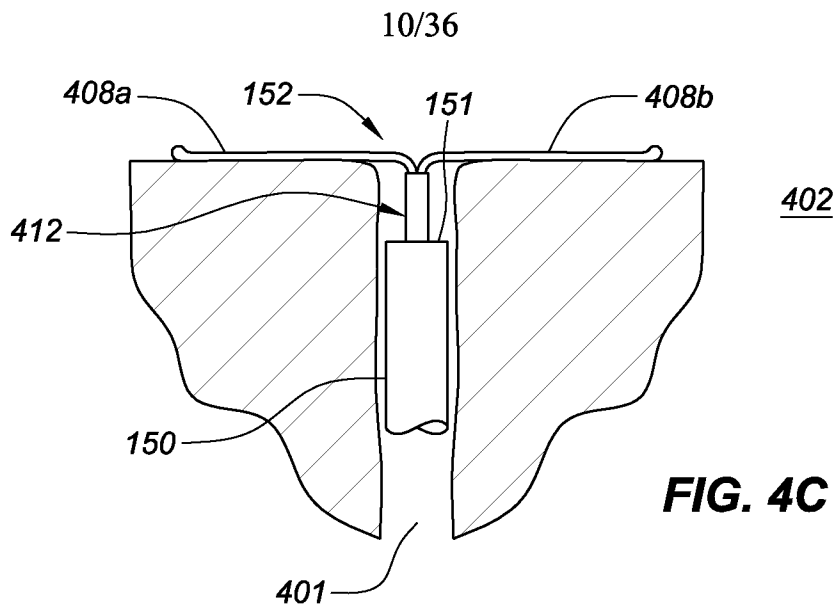
9/36

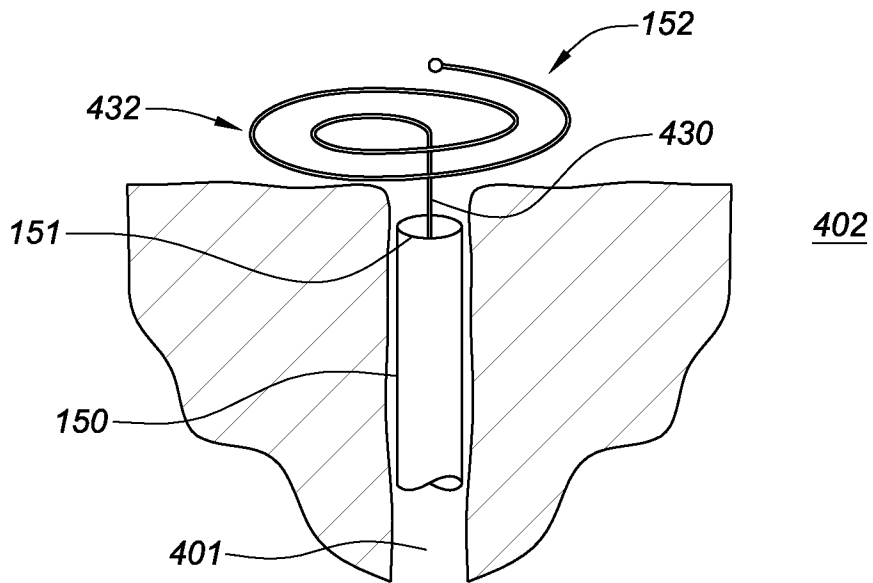


**FIG. 4A**

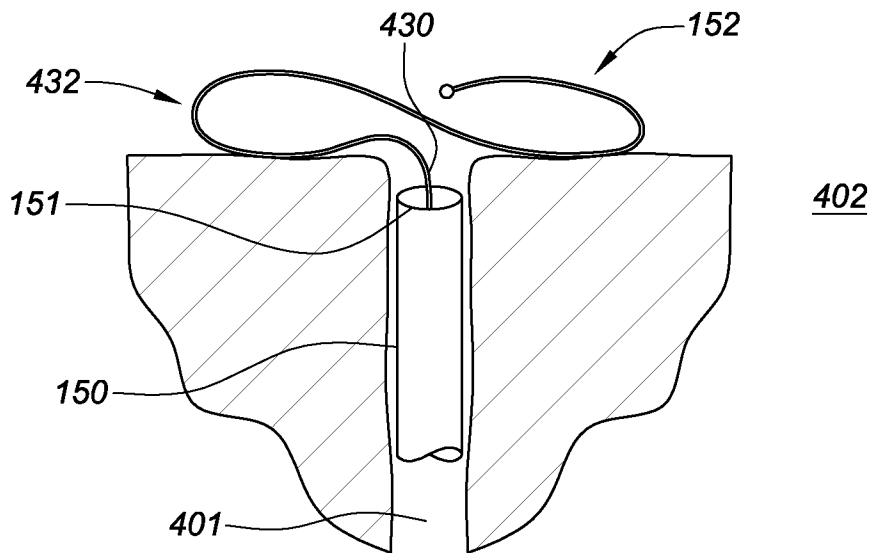


**FIG. 4B**



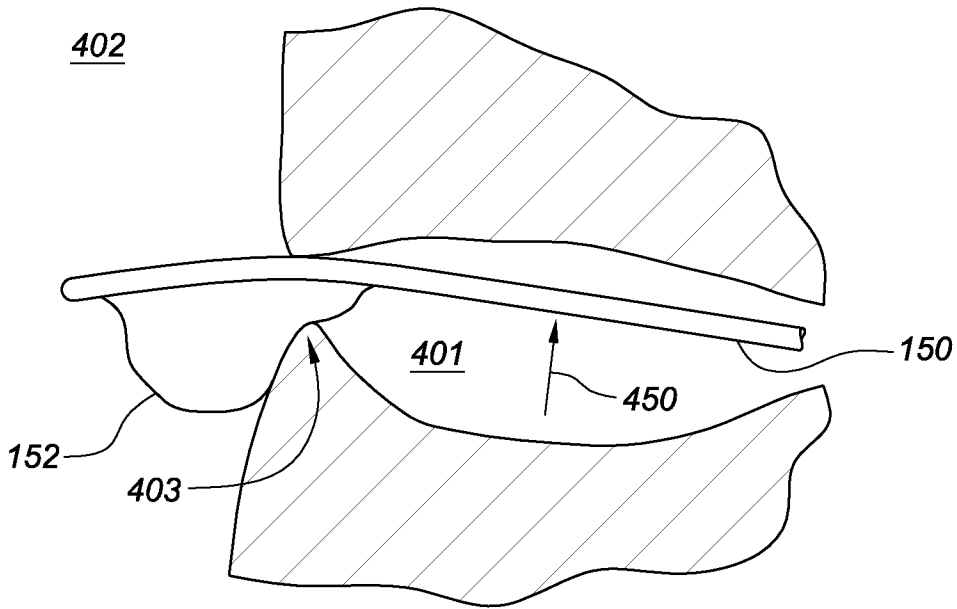


**FIG. 4F**

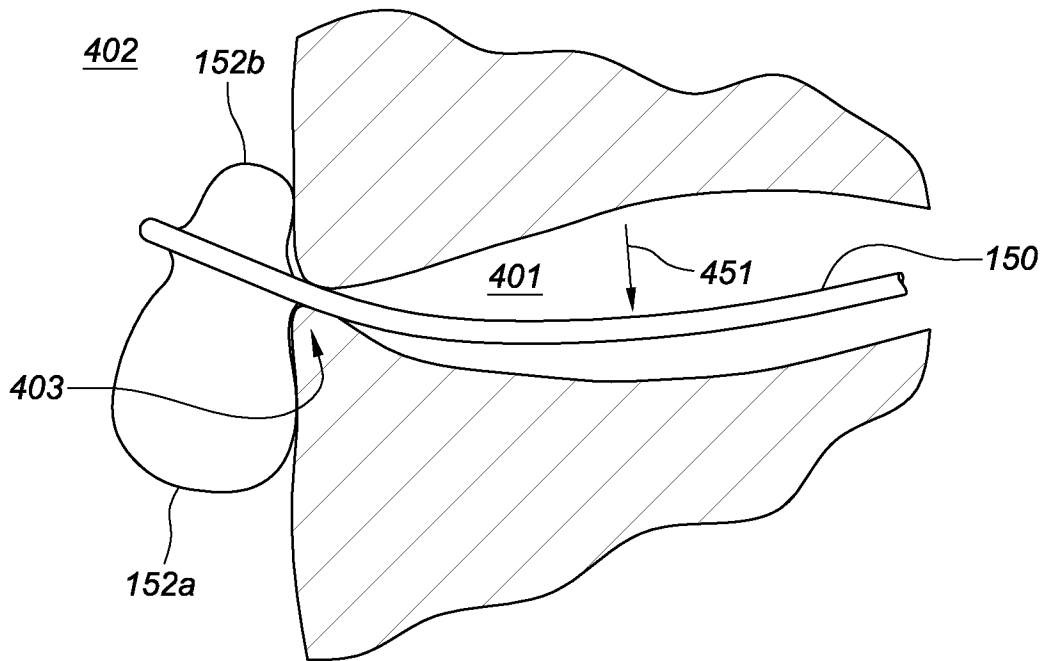


**FIG. 4G**

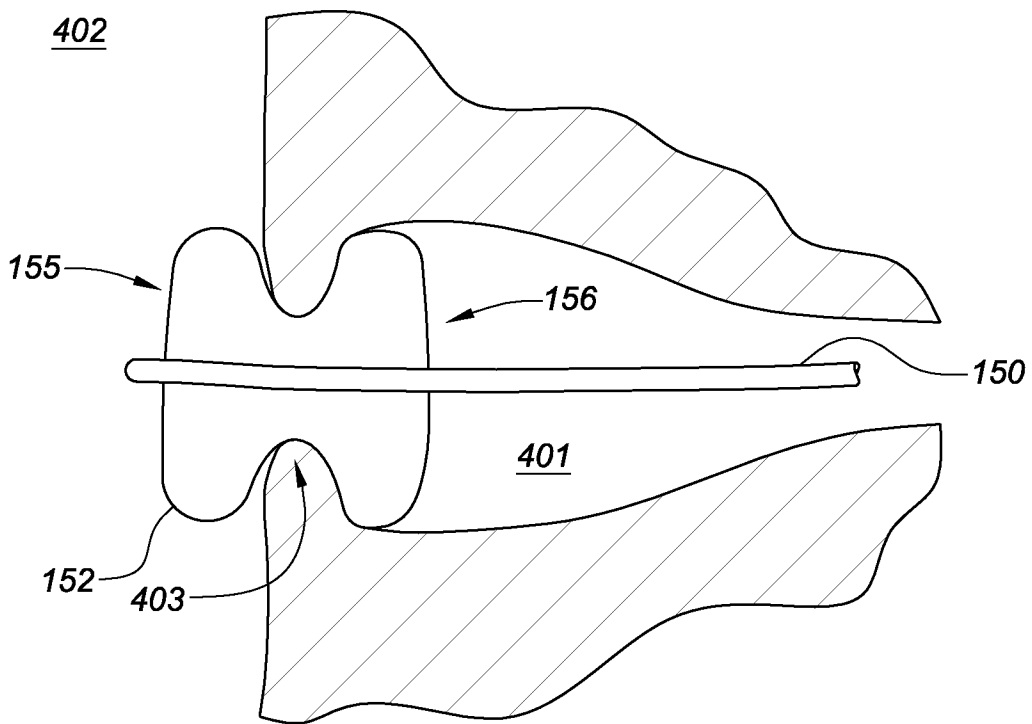
12/36



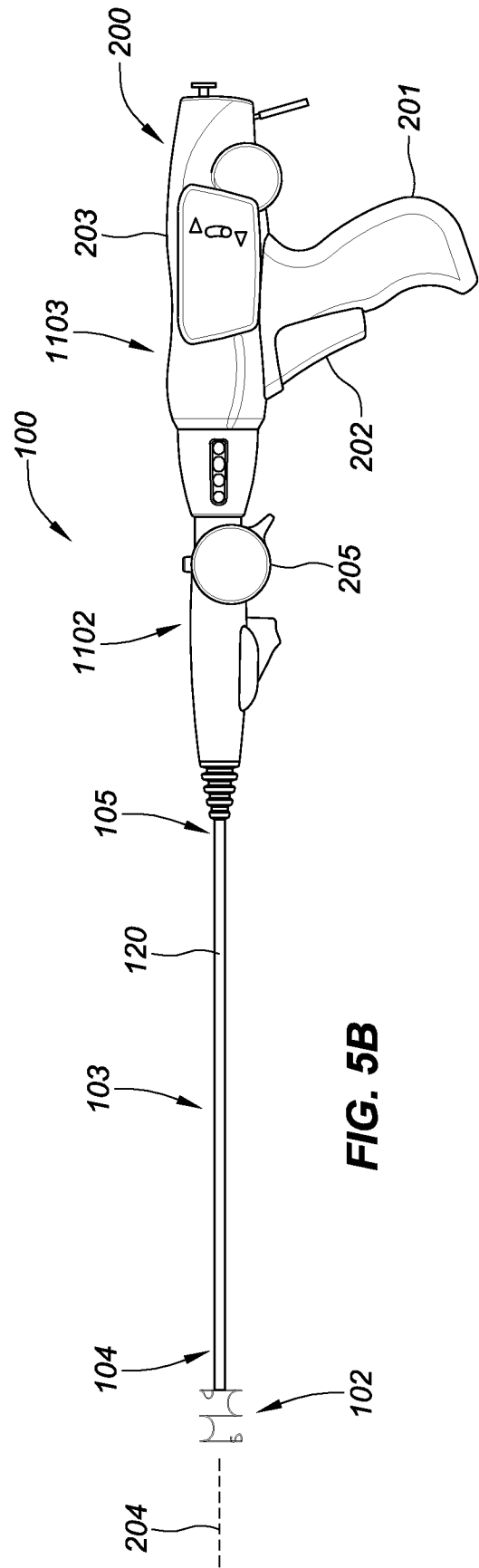
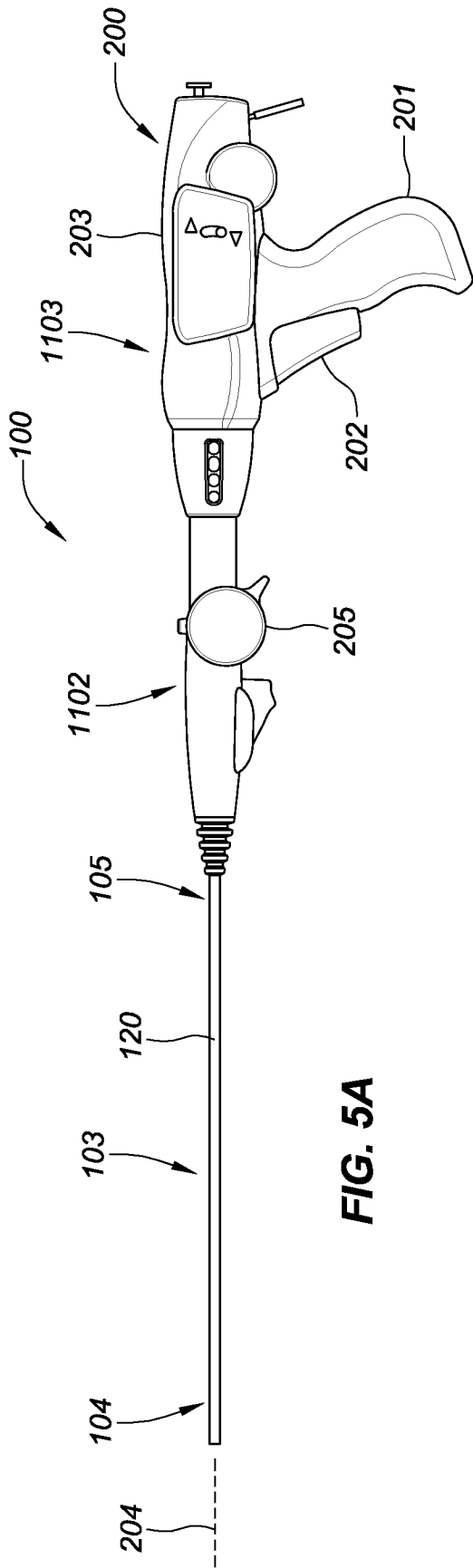
**FIG. 4H**

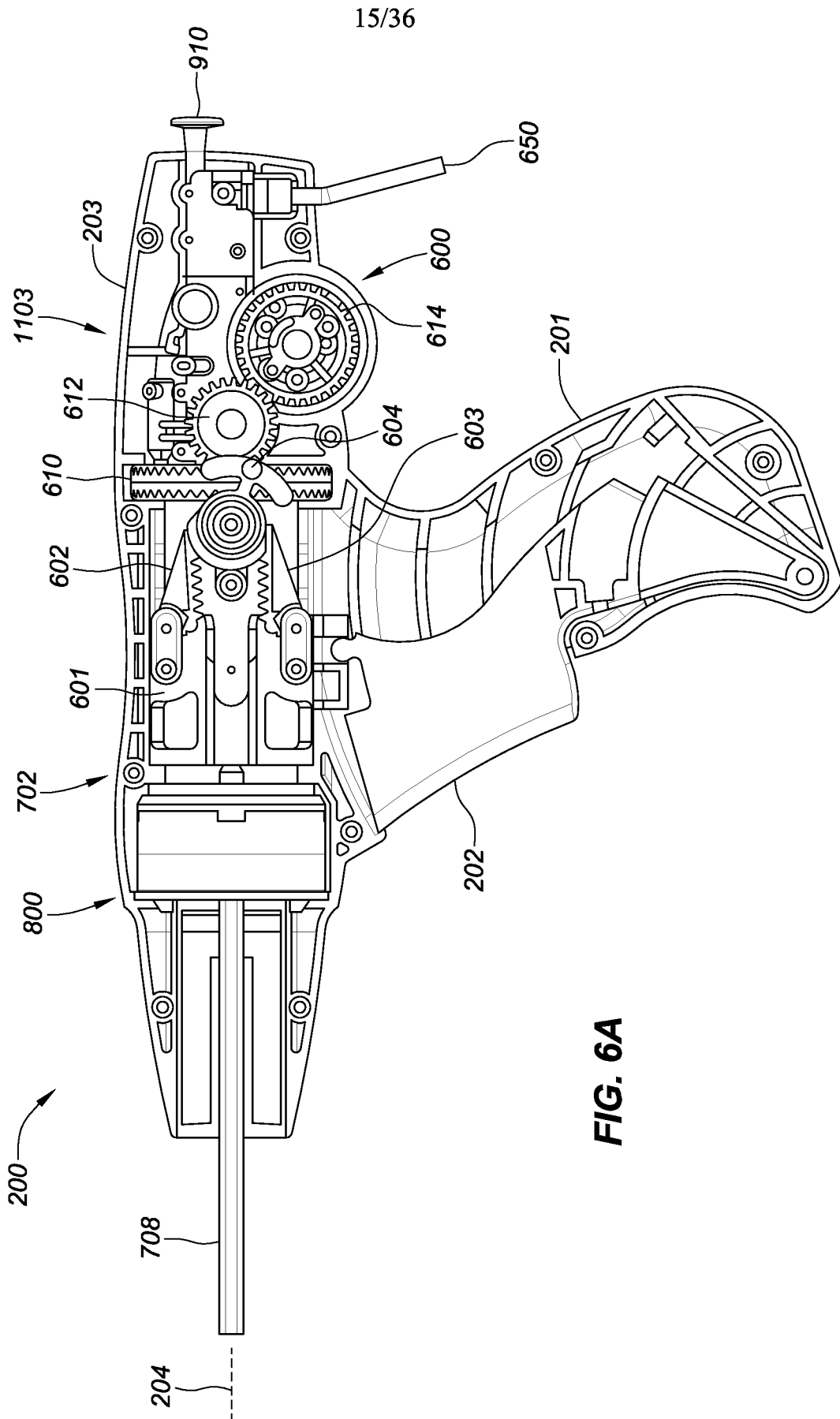


**FIG. 4I**

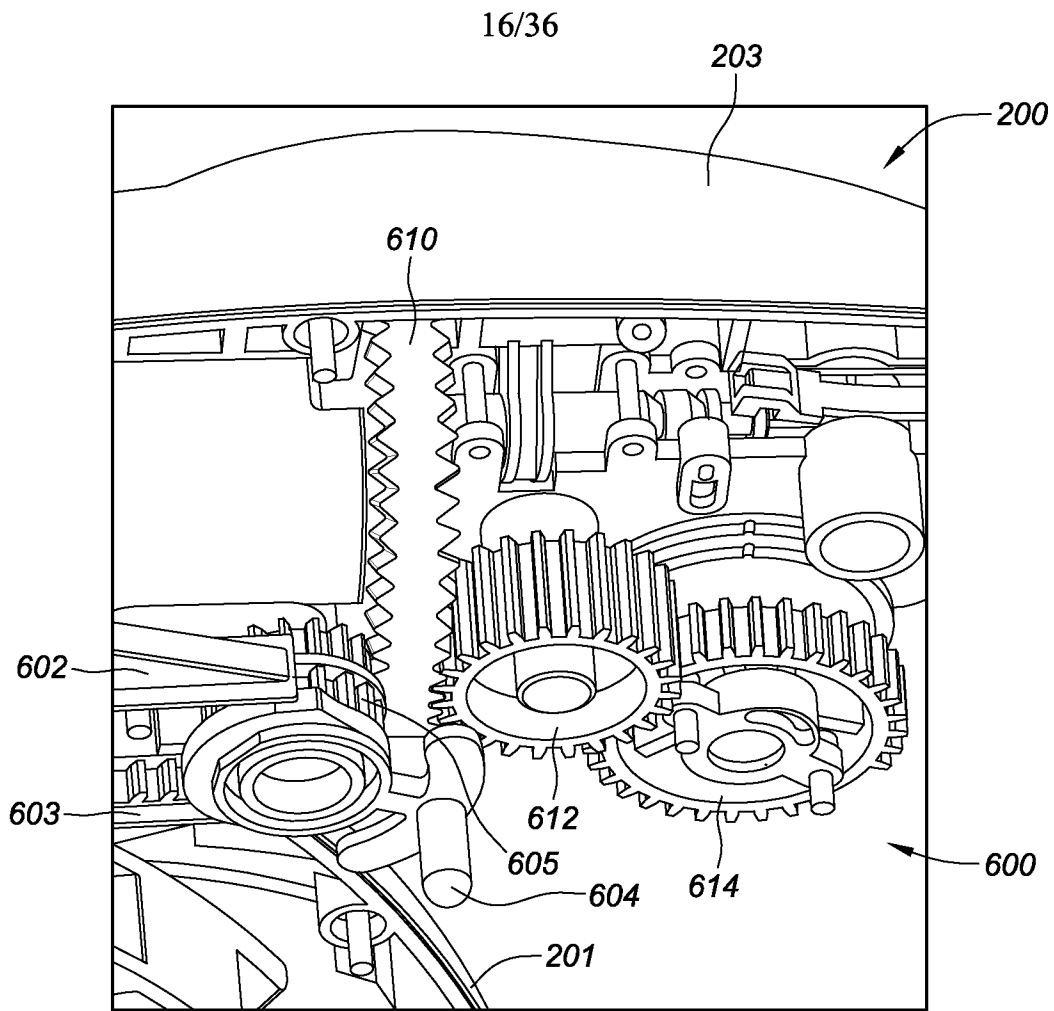


**FIG. 4J**

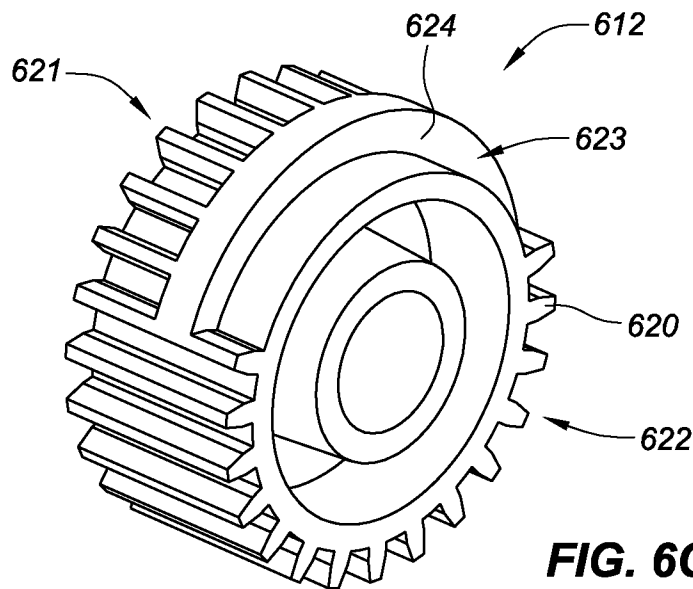




**FIG. 6A**

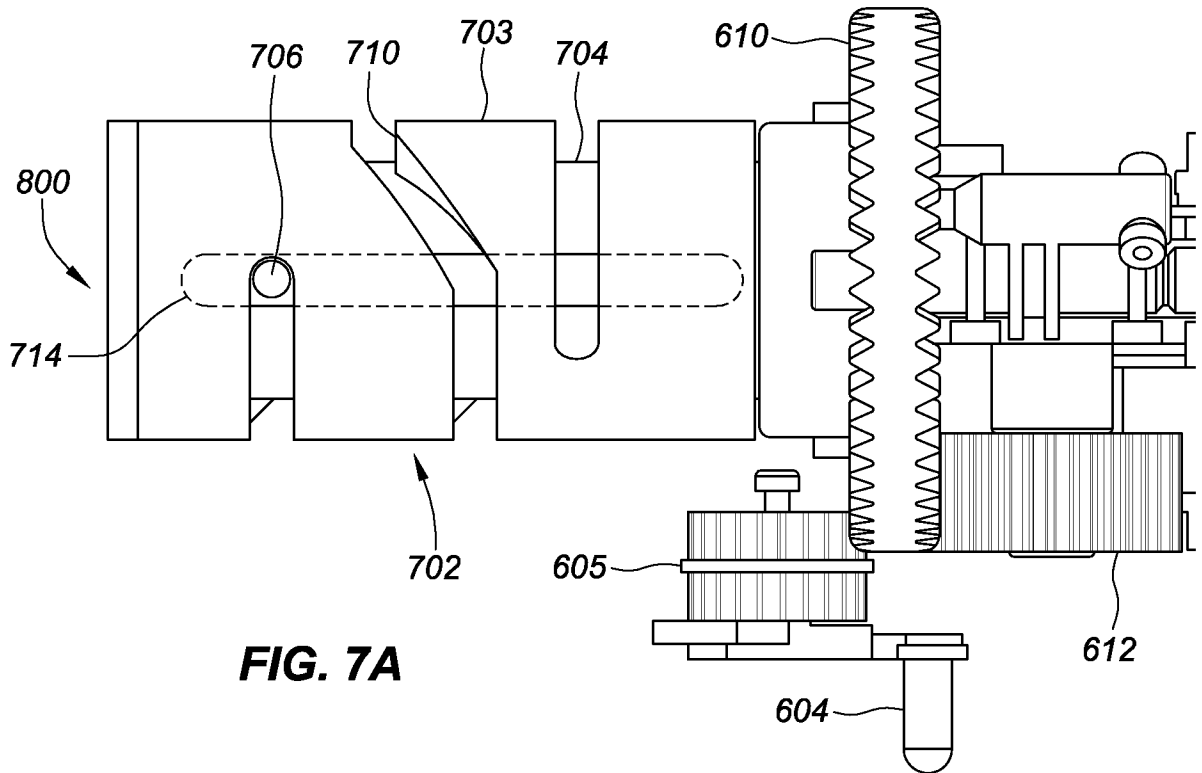


**FIG. 6B**

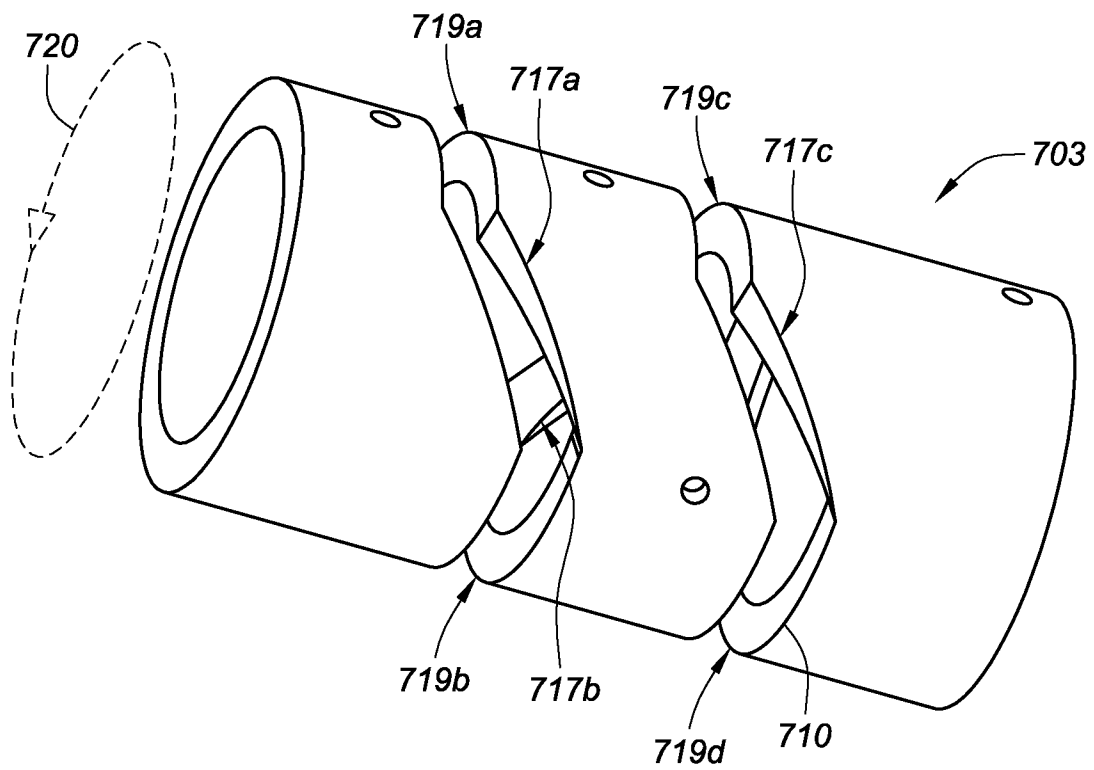


**FIG. 6C**

17/36



**FIG. 7A**



**FIG. 7B**

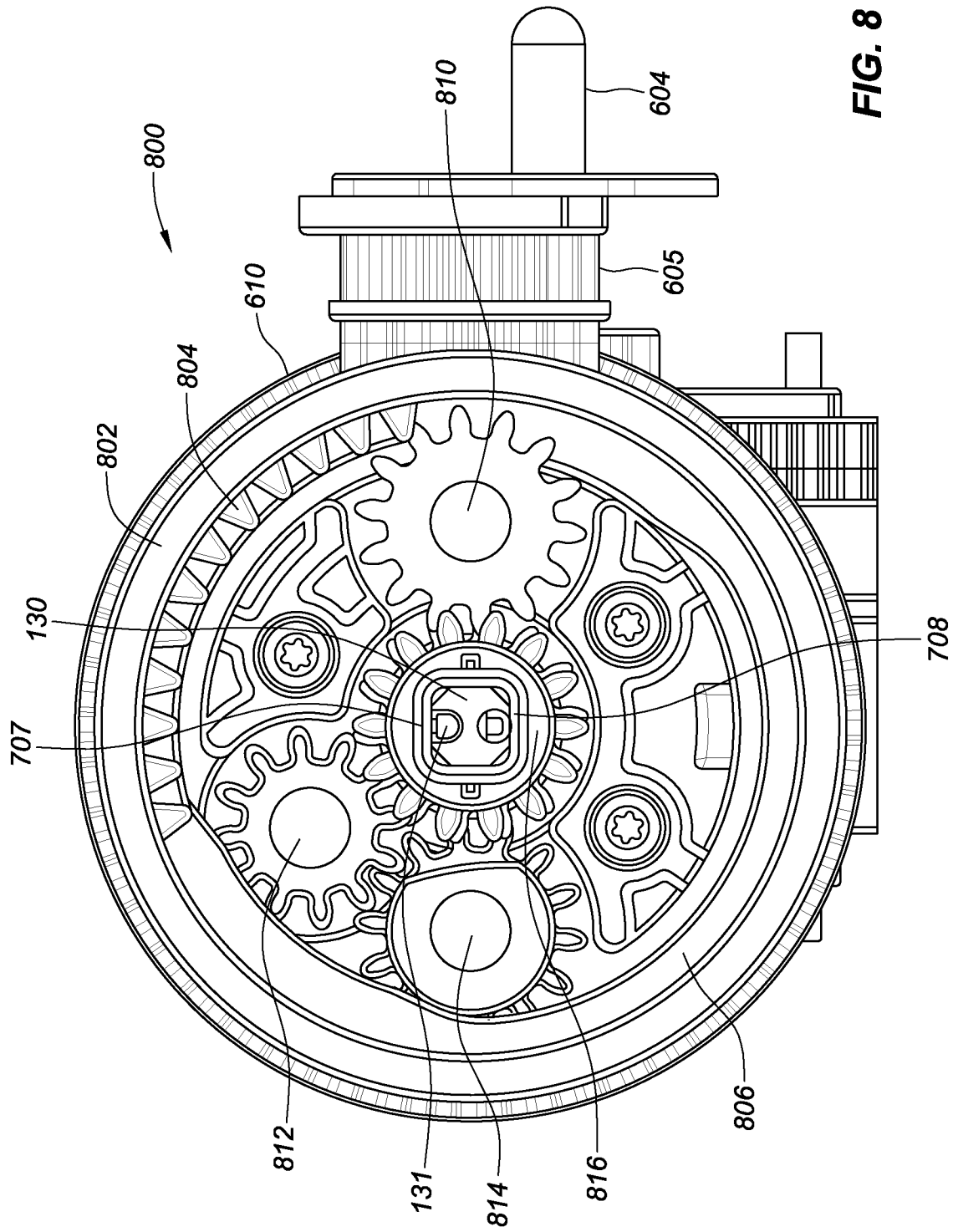
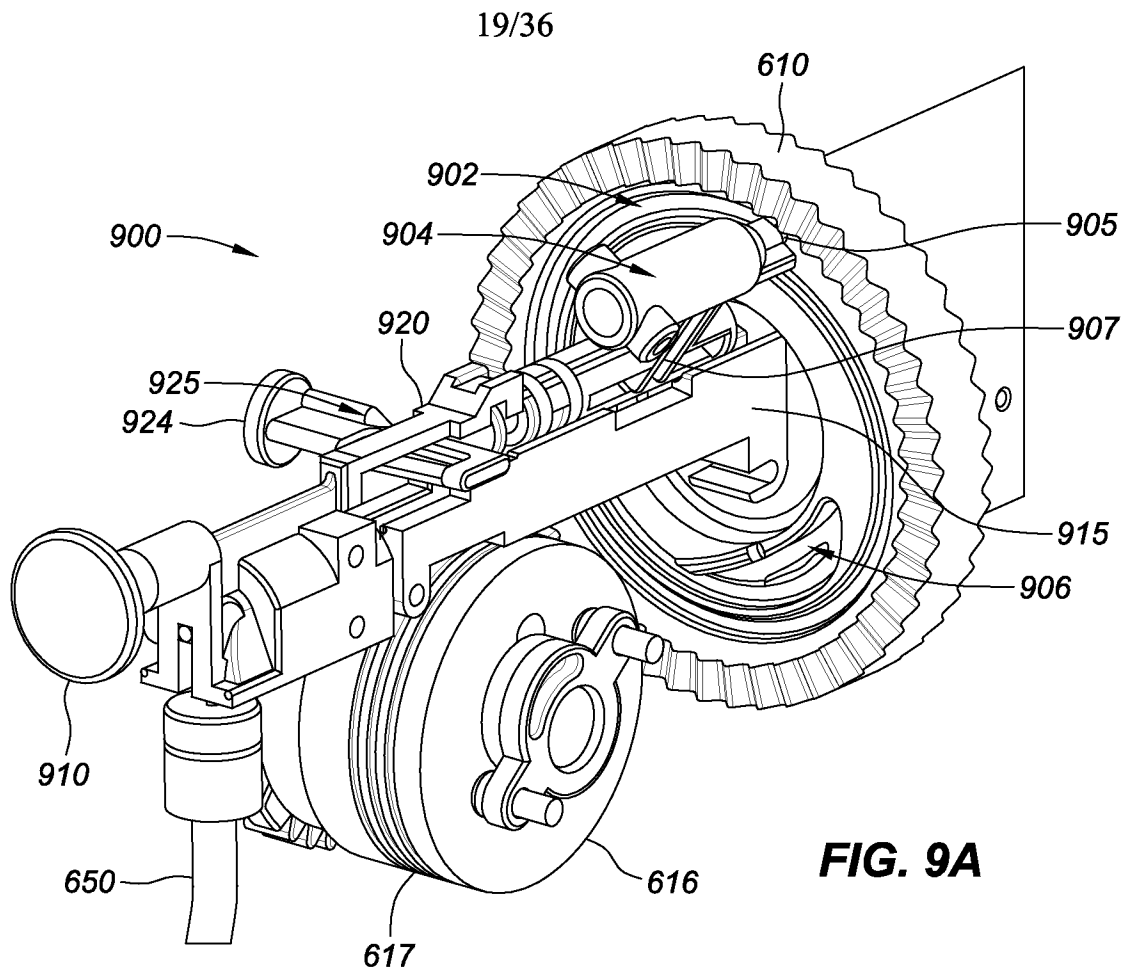
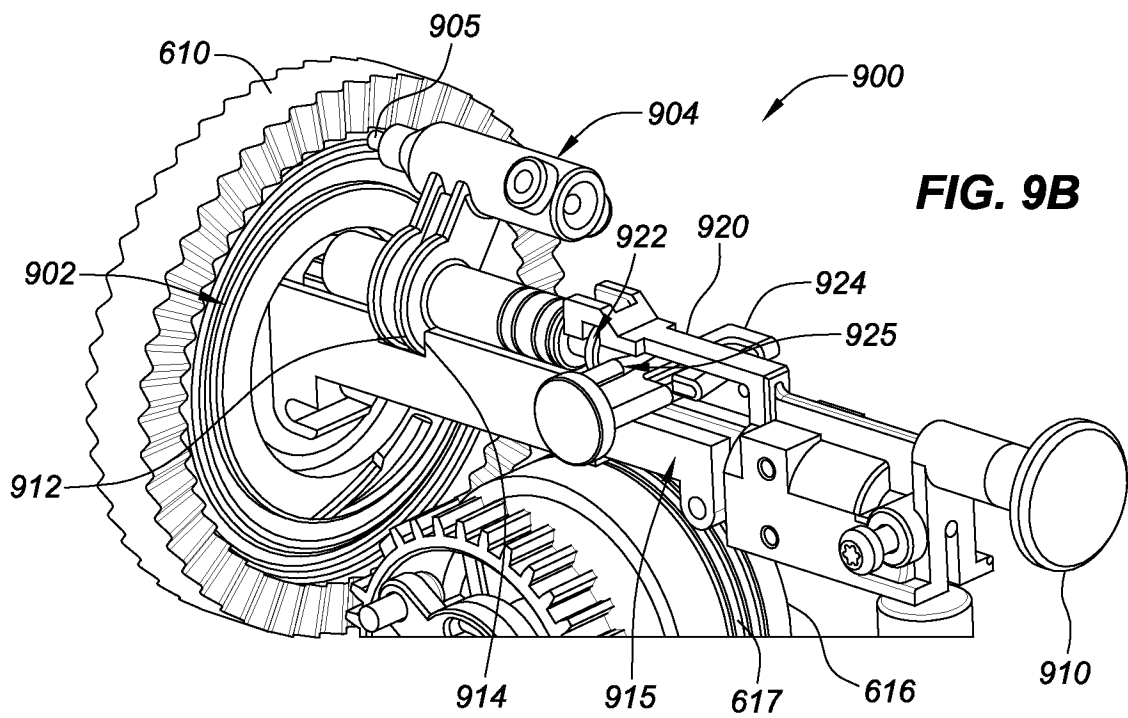


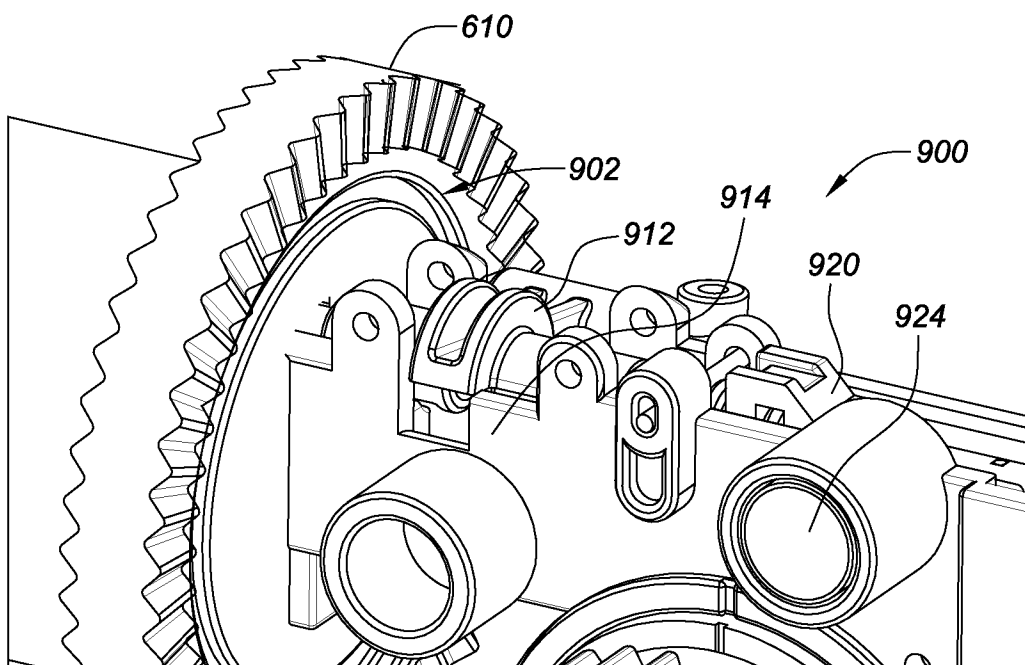
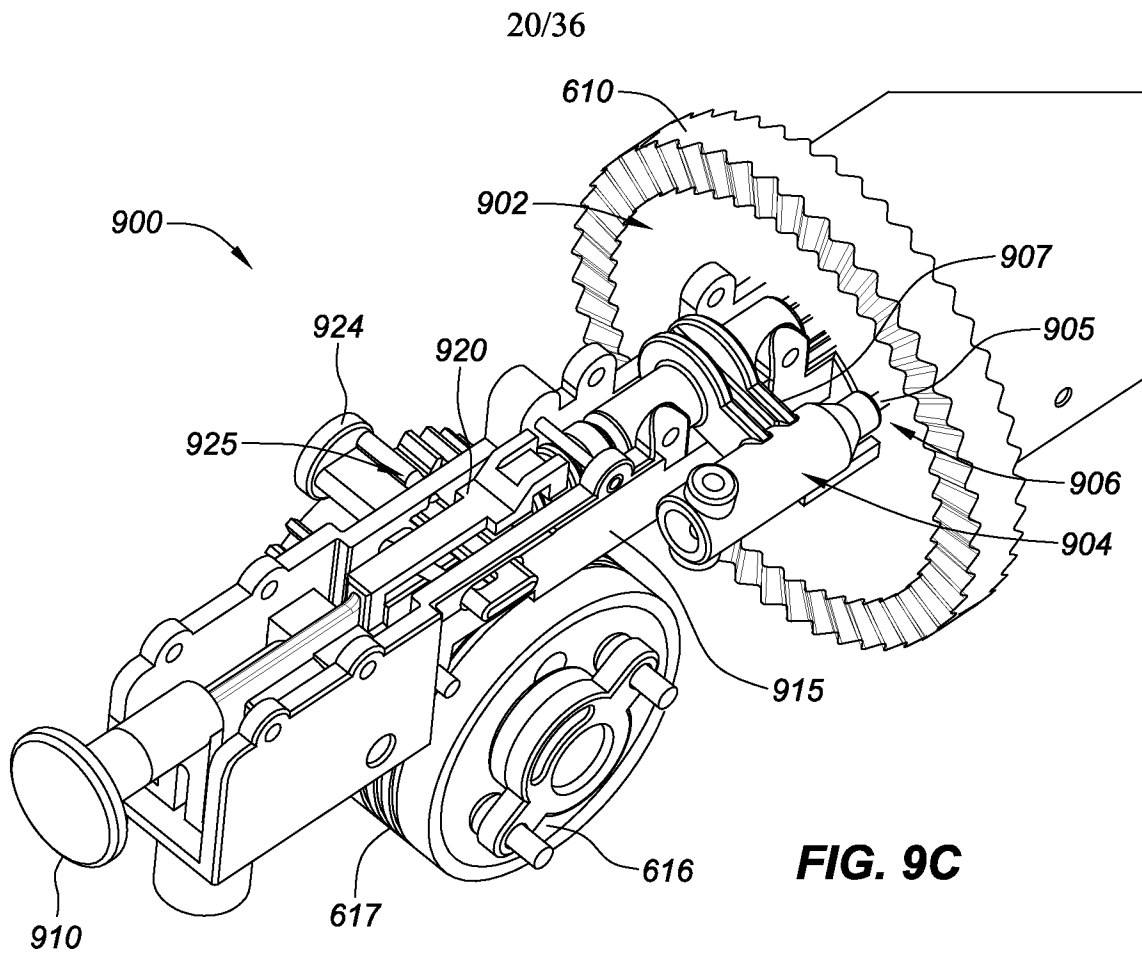
FIG. 8



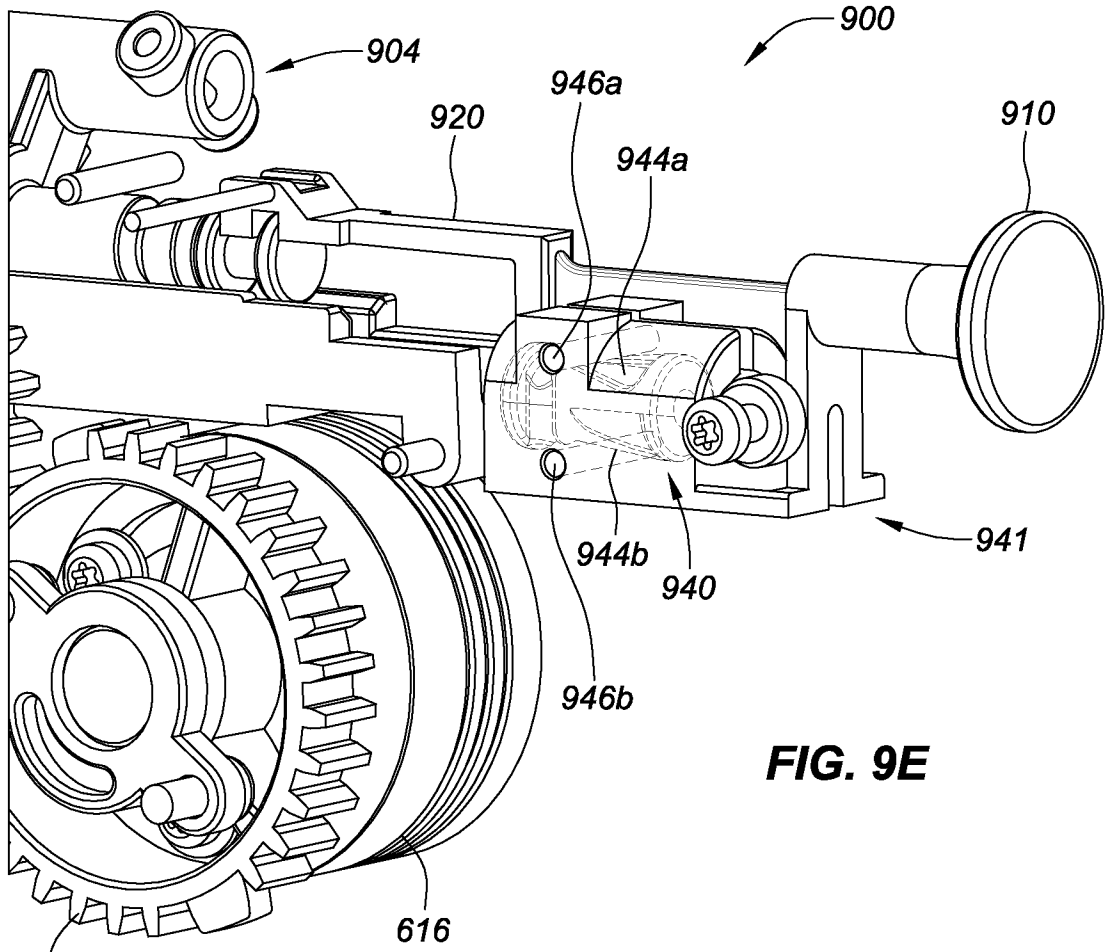
**FIG. 9A**



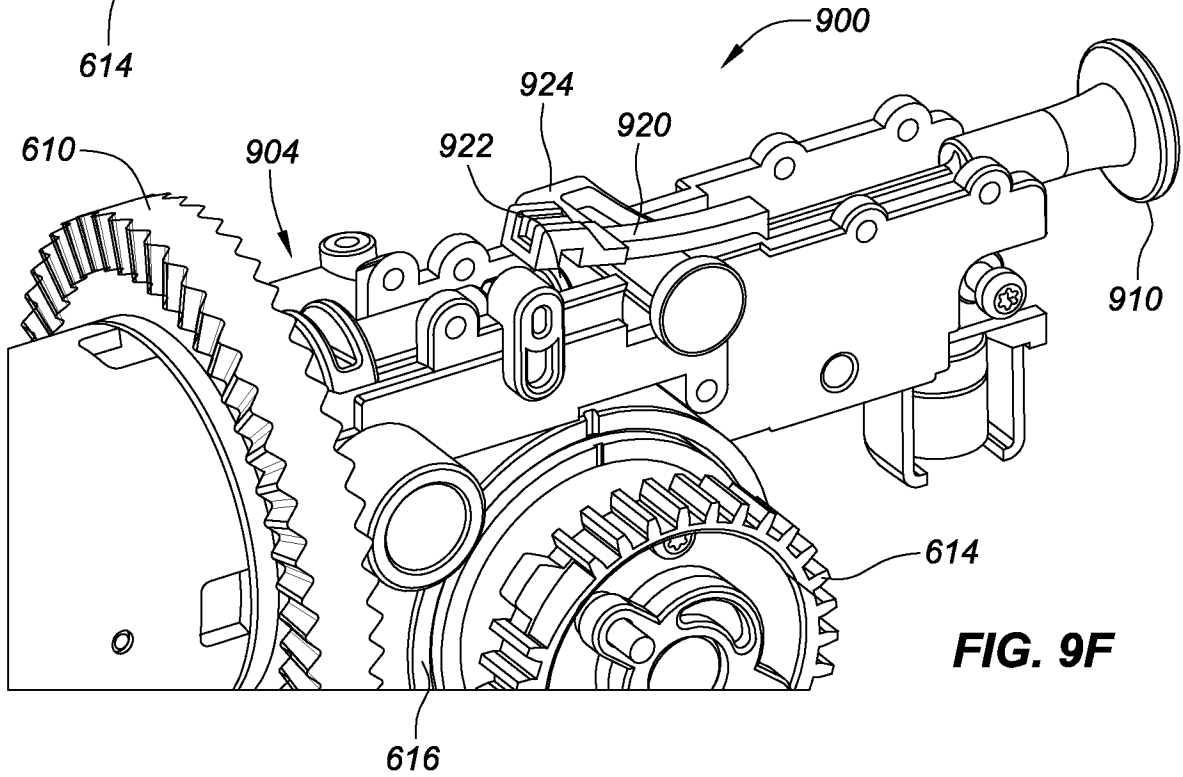
**FIG. 9B**



21/36



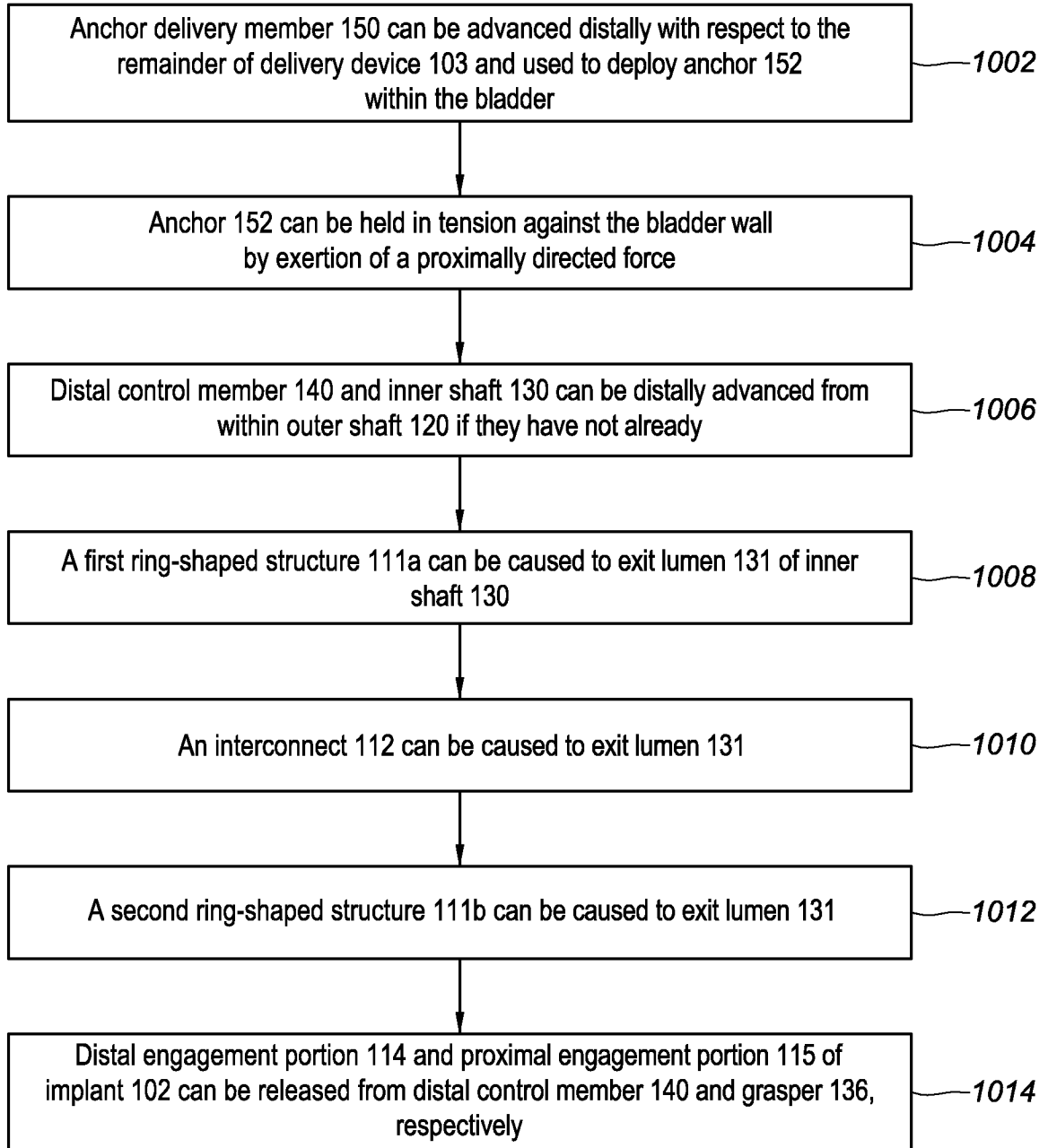
**FIG. 9E**



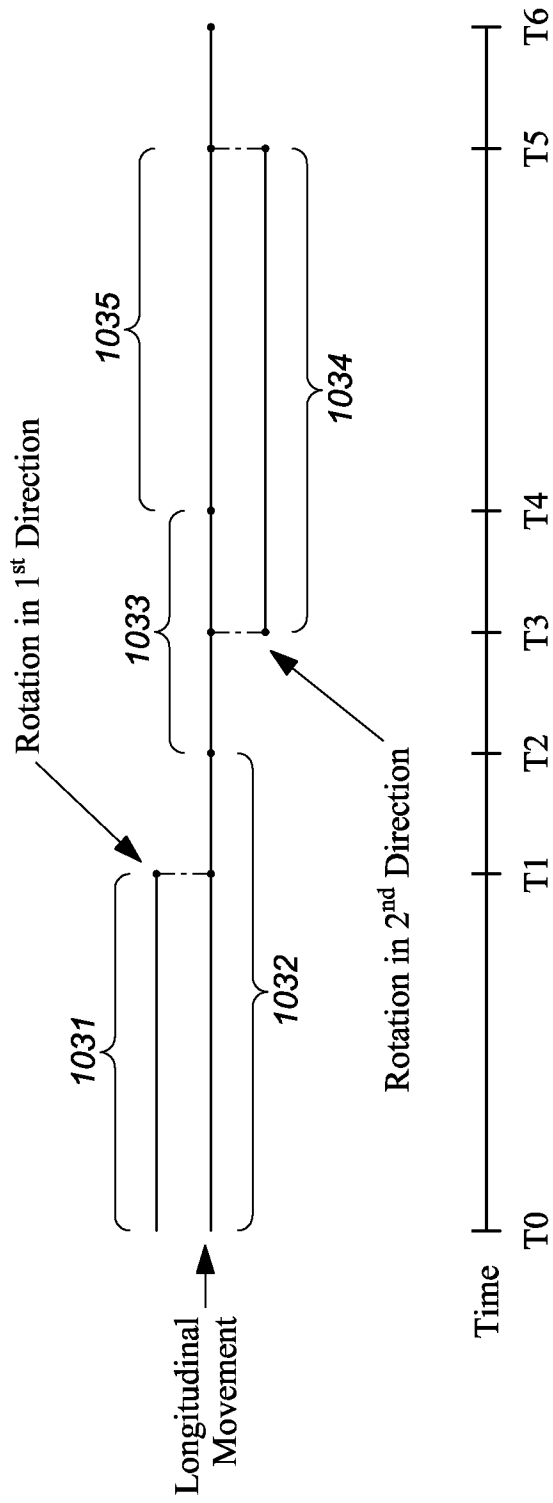
**FIG. 9F**

22/36

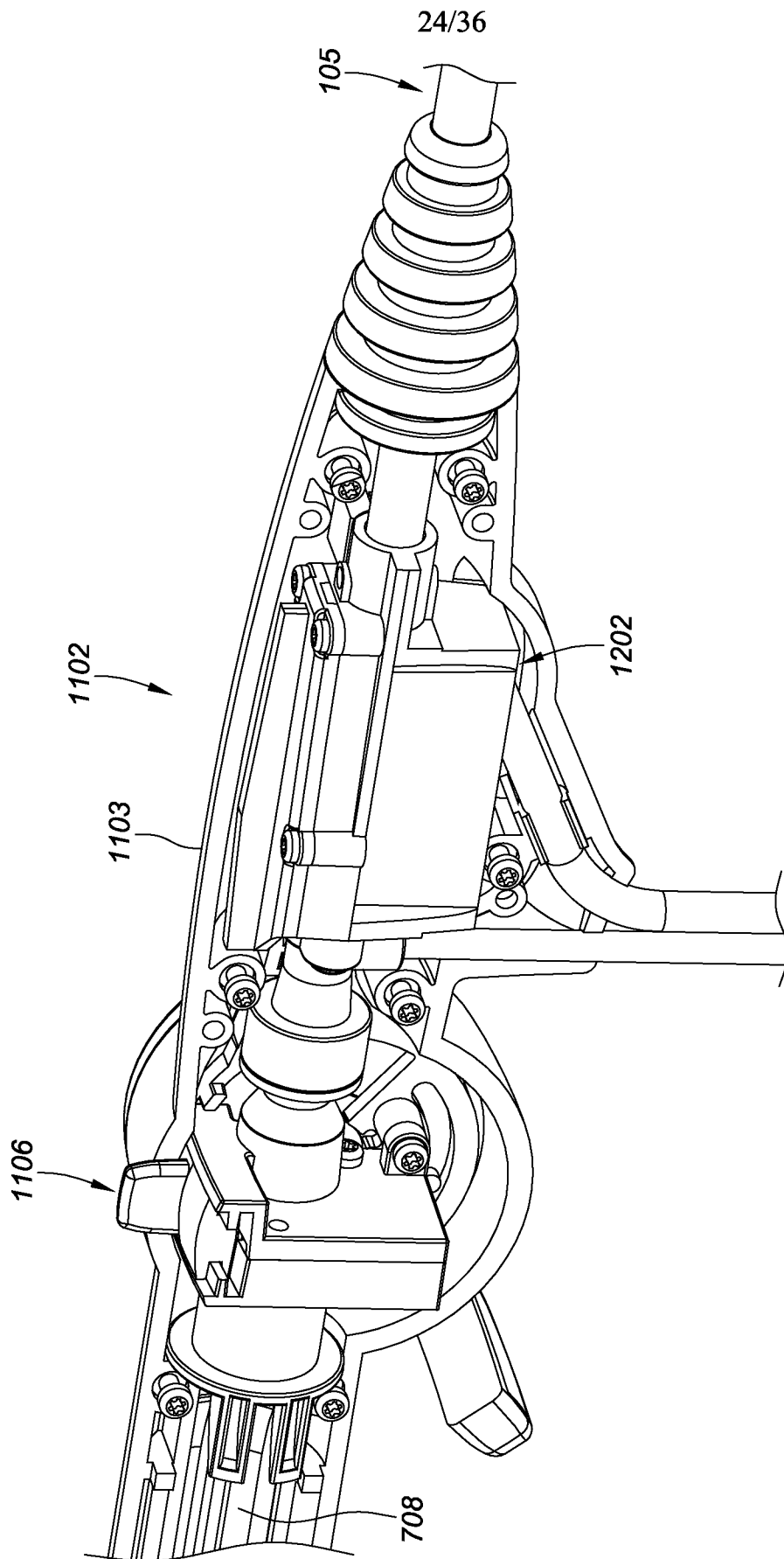
1000



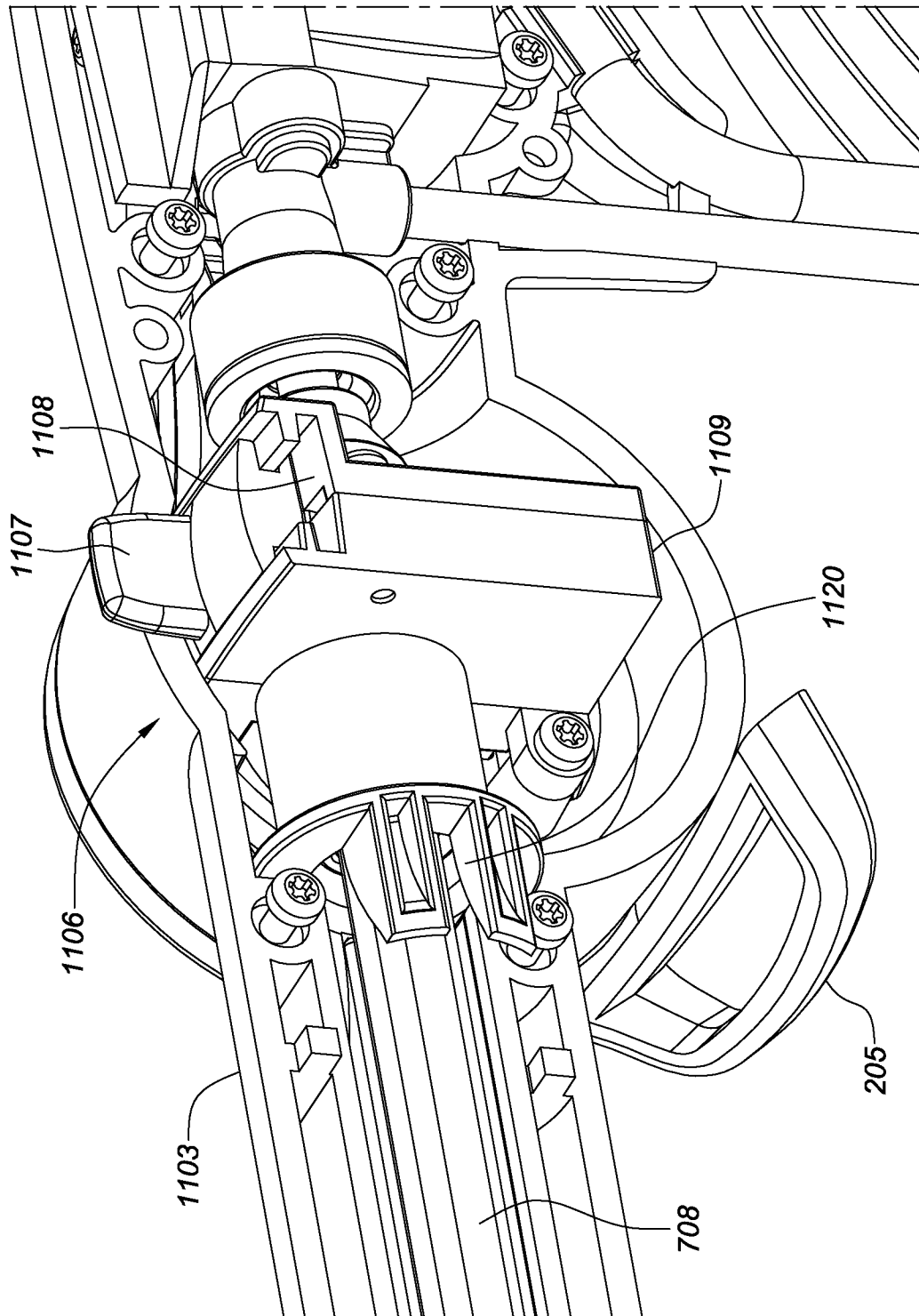
**FIG. 10A**



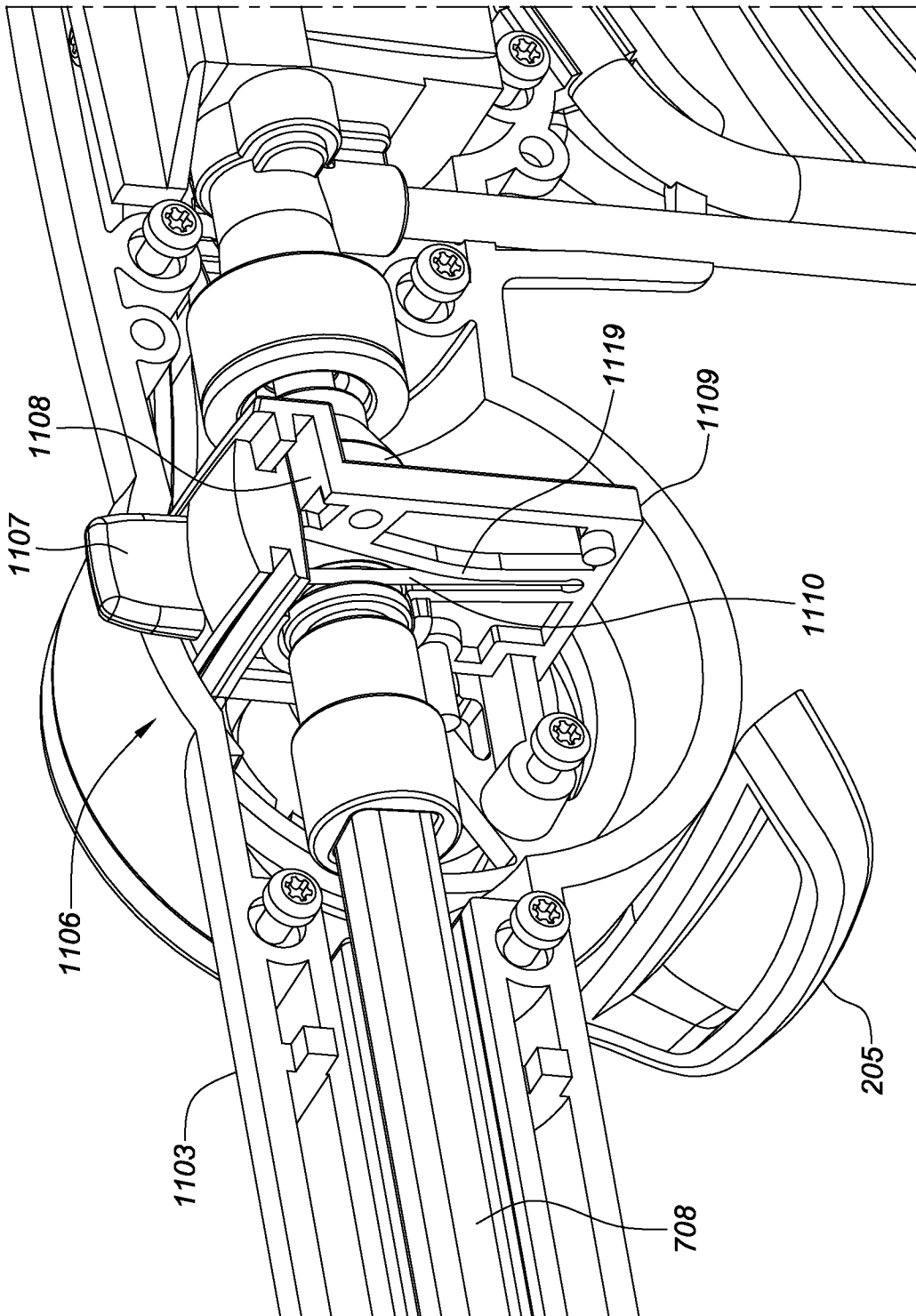
**FIG. 10B**



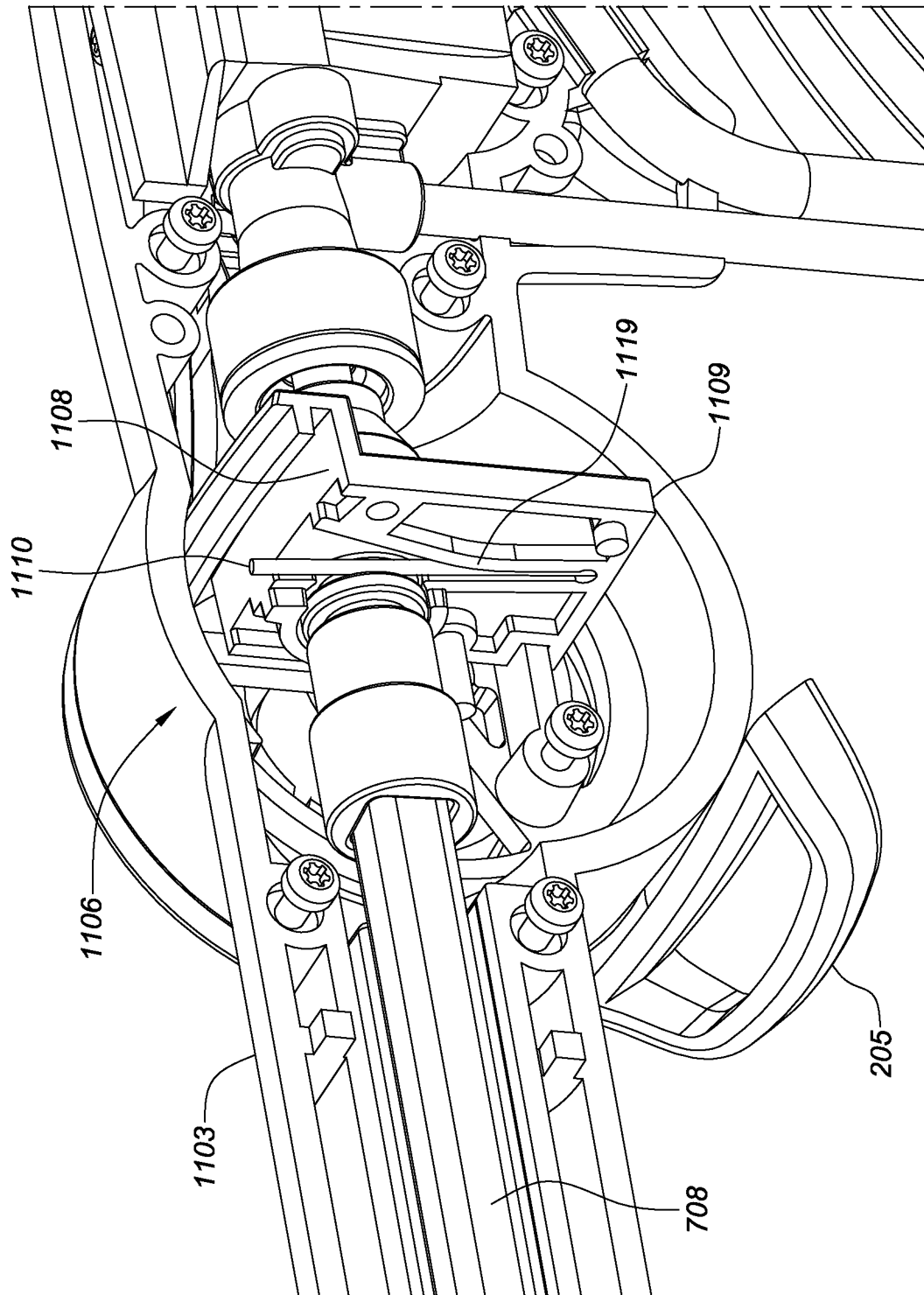
**FIG. 11A**



**FIG. 11B**



**FIG. 11C**



**FIG. 11D**

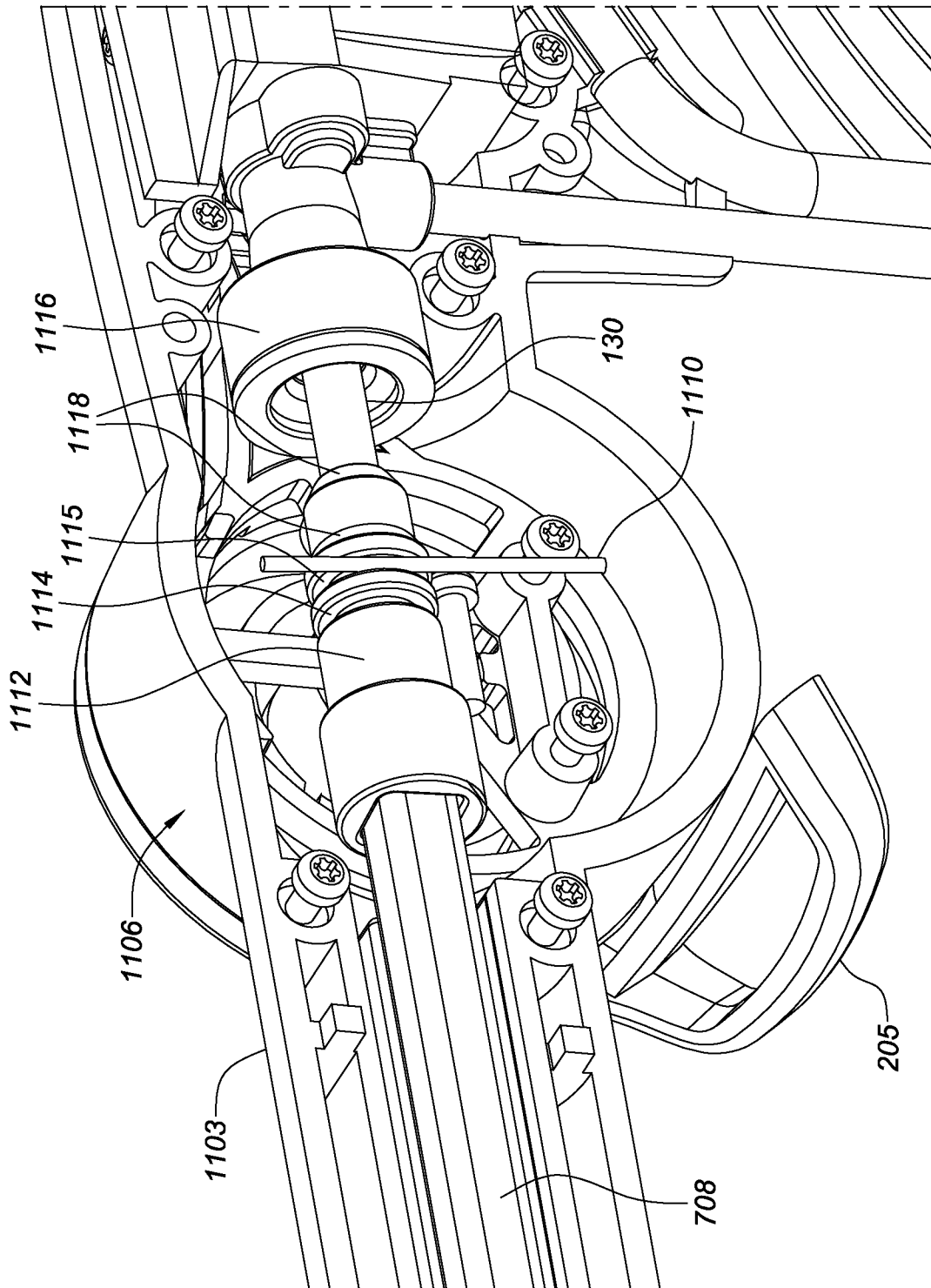
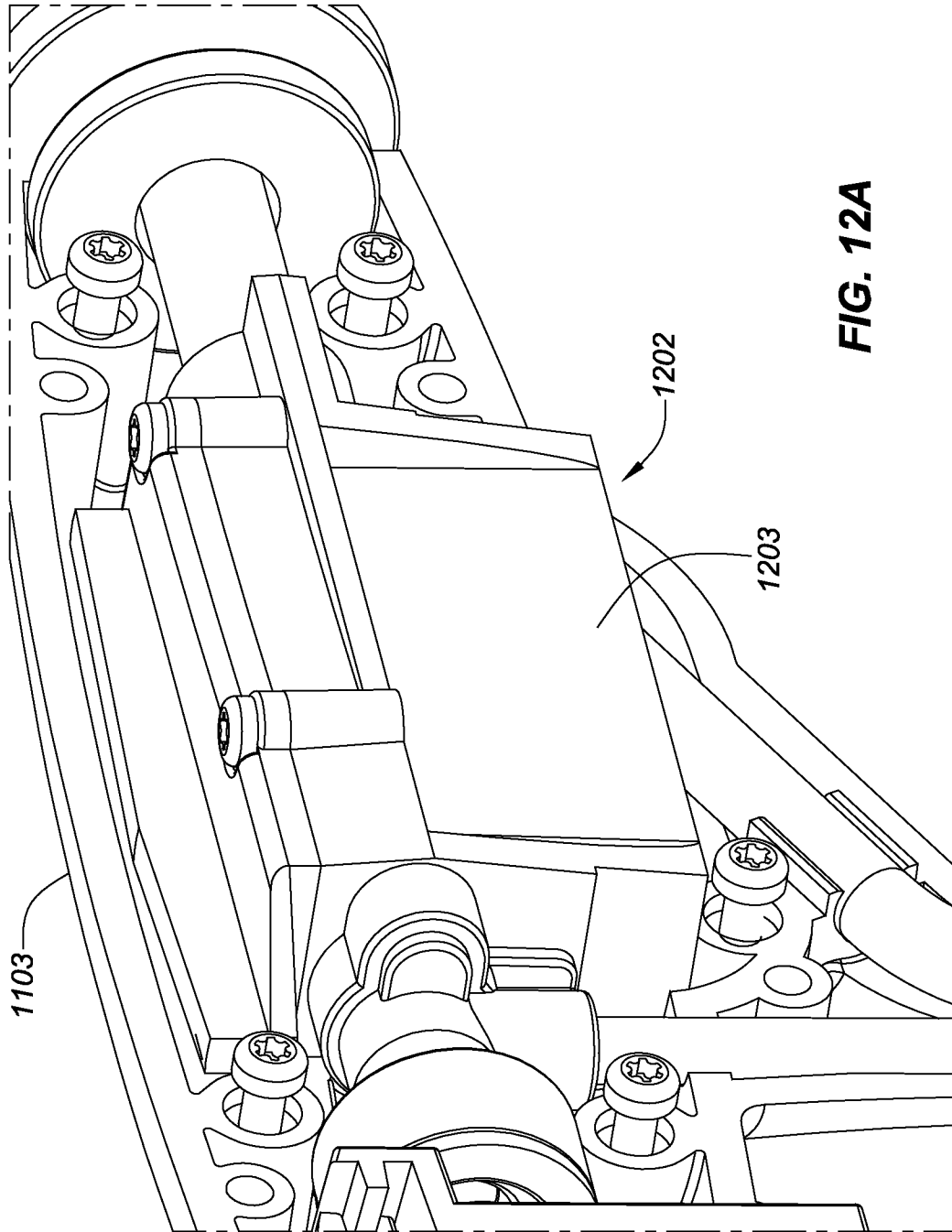
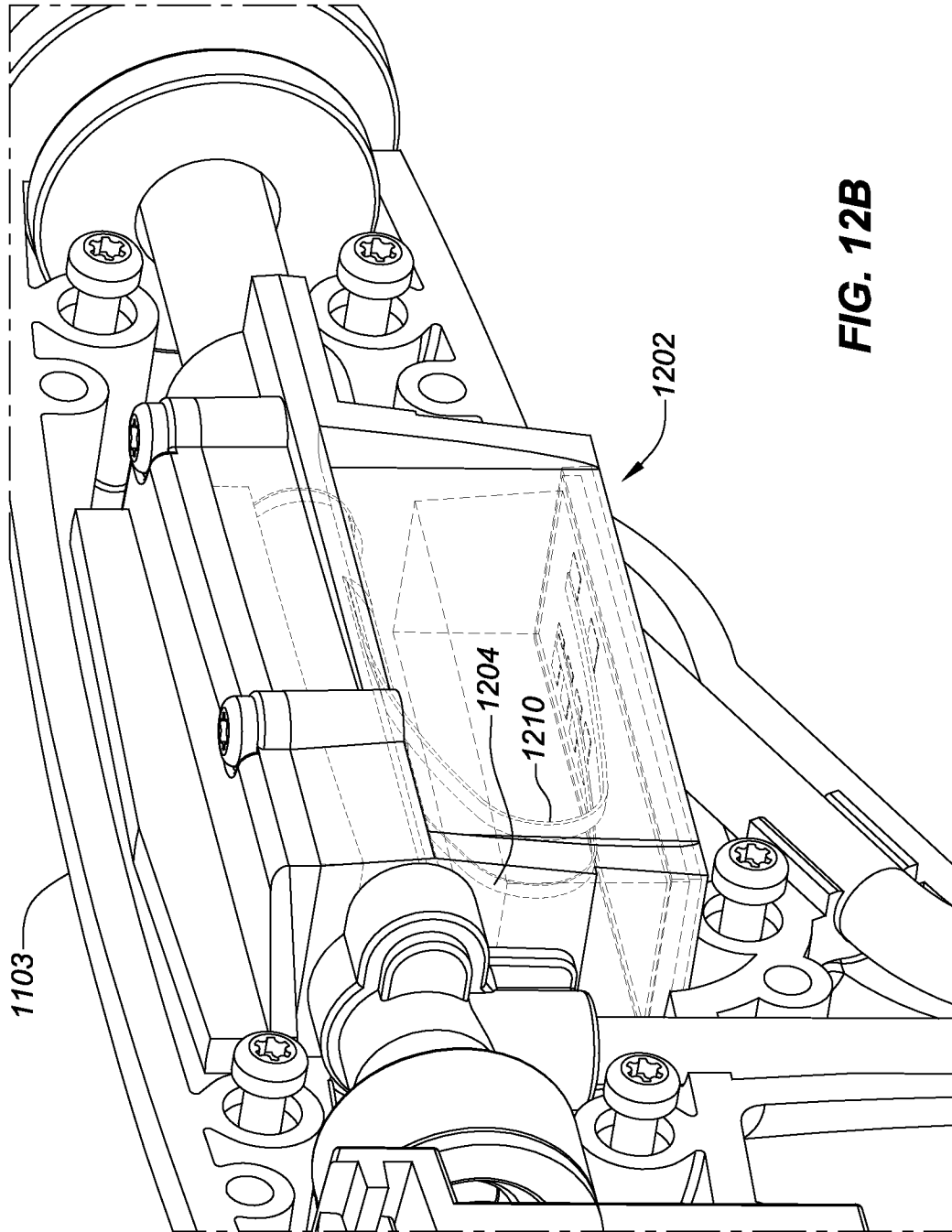


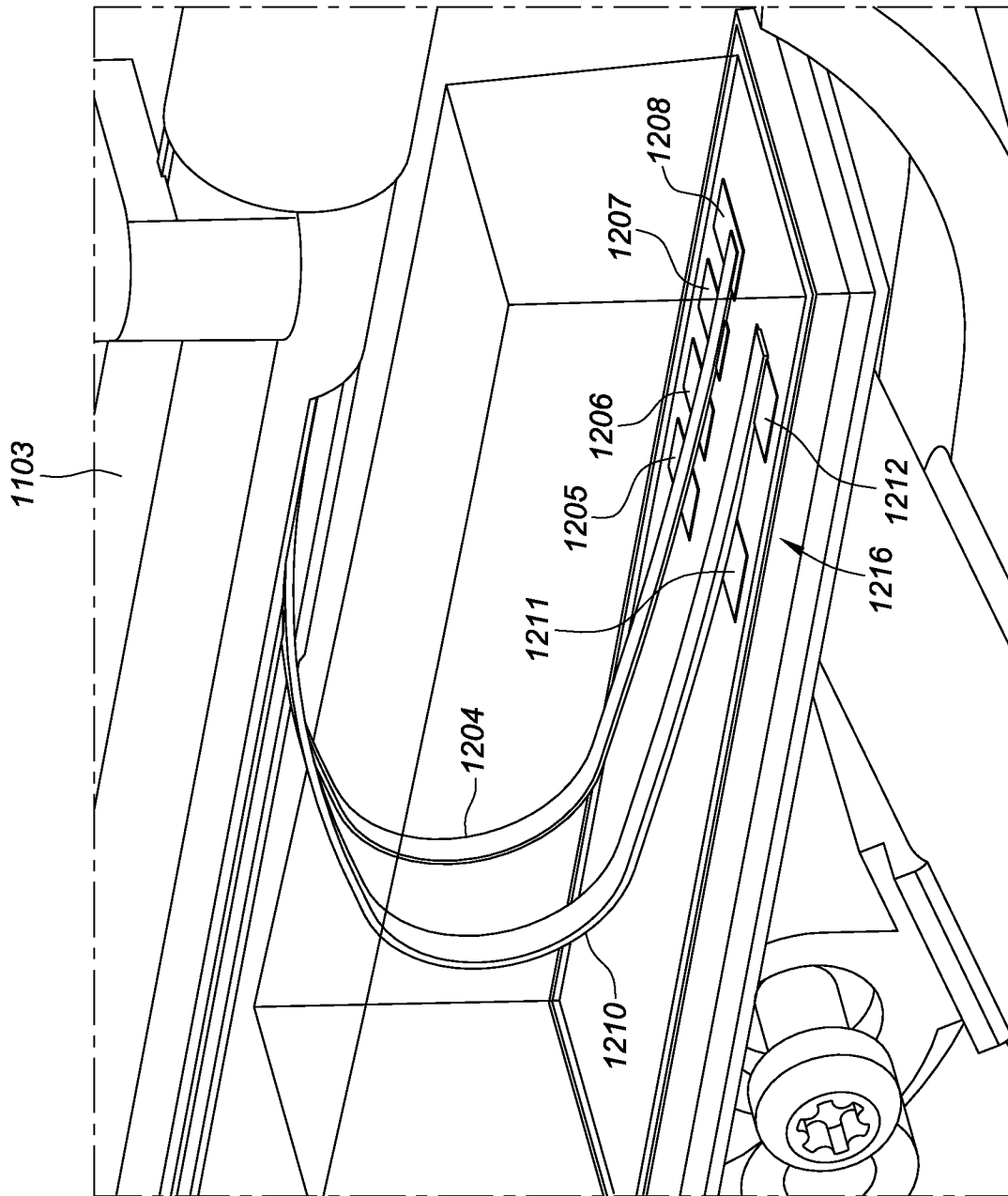
FIG. 11E



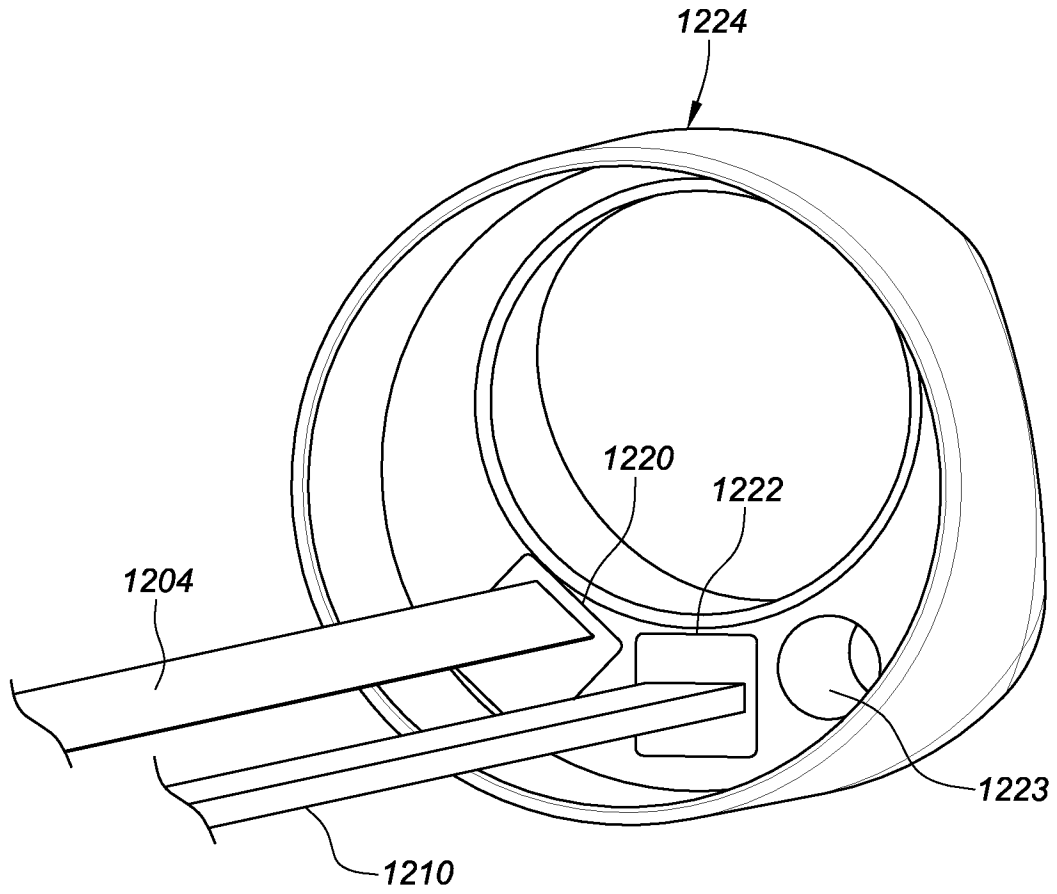
**FIG. 12A**



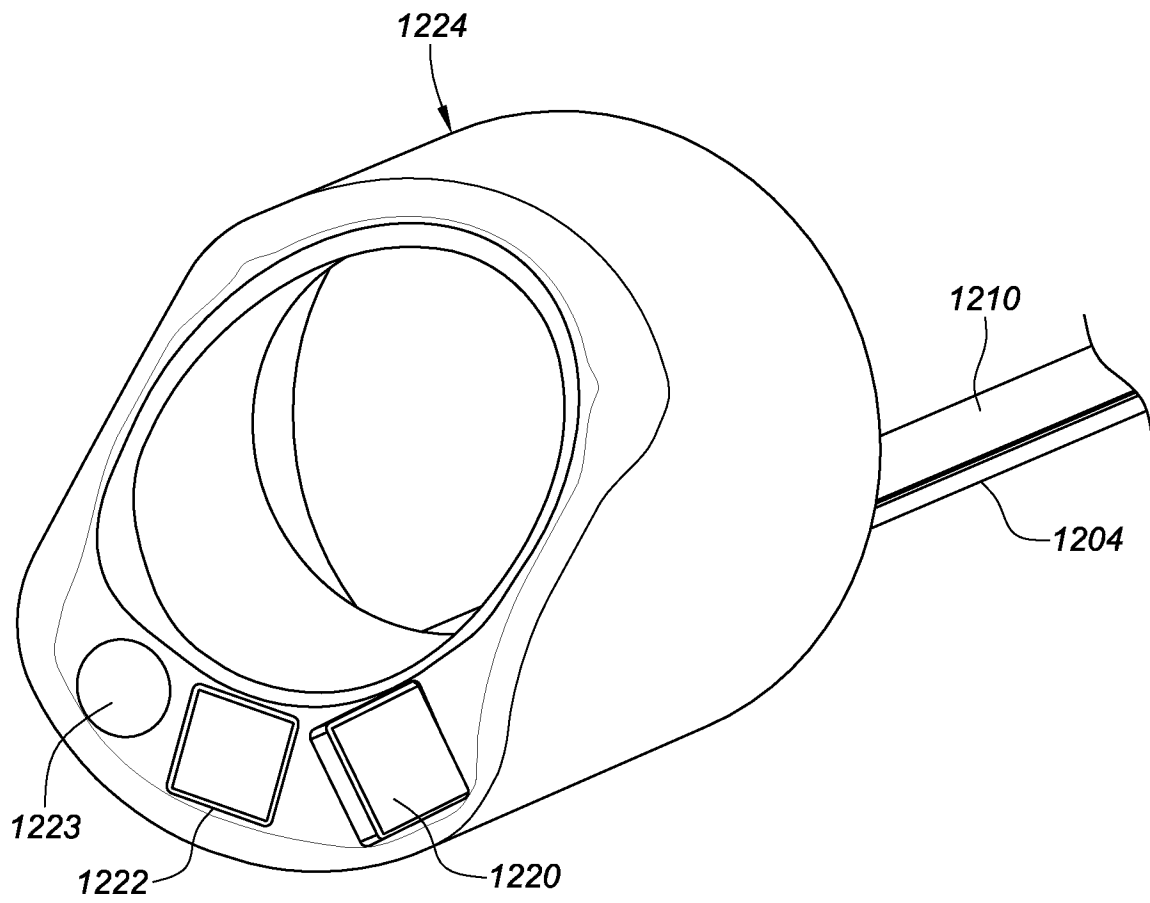
**FIG. 12B**



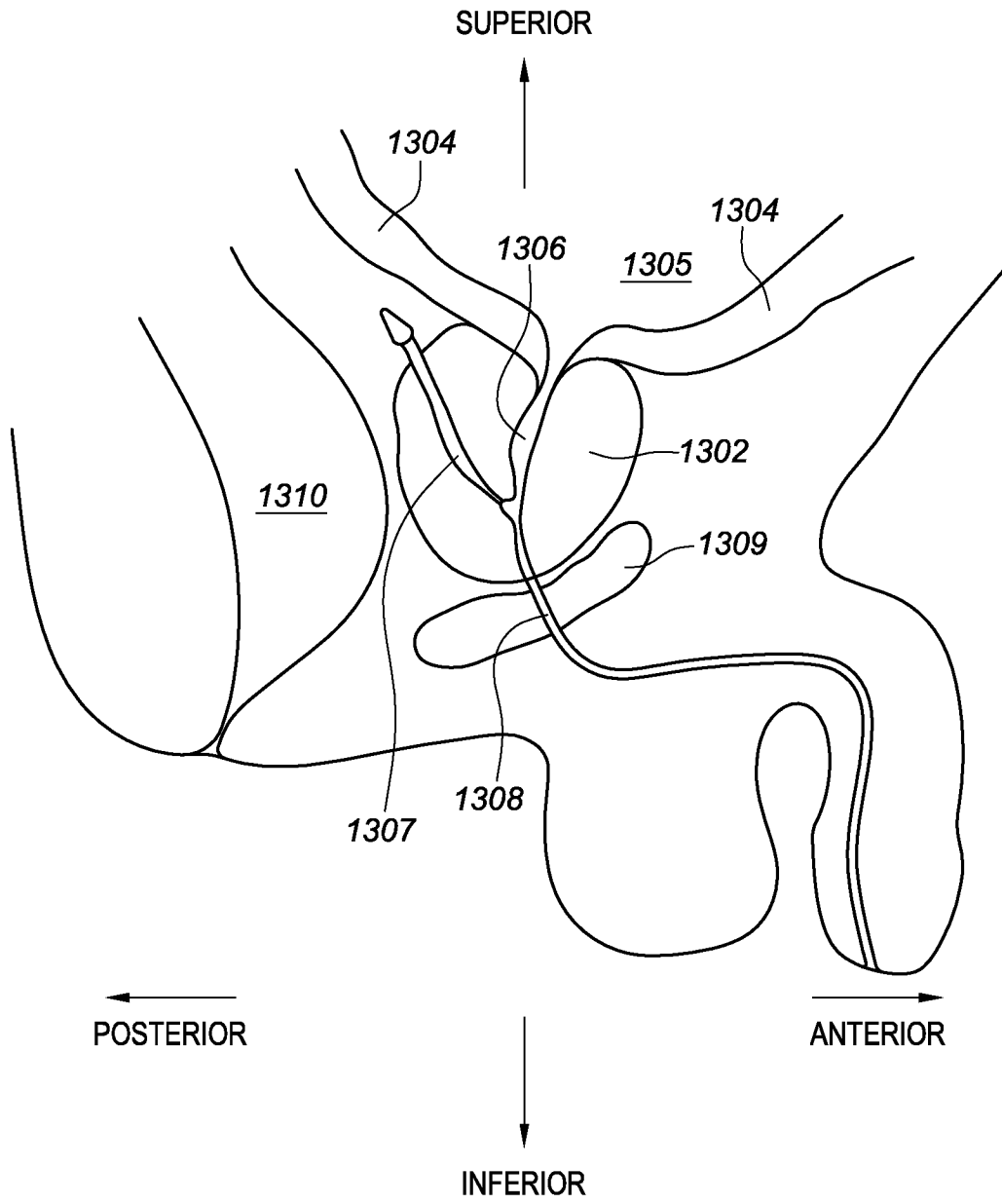
**FIG. 12C**



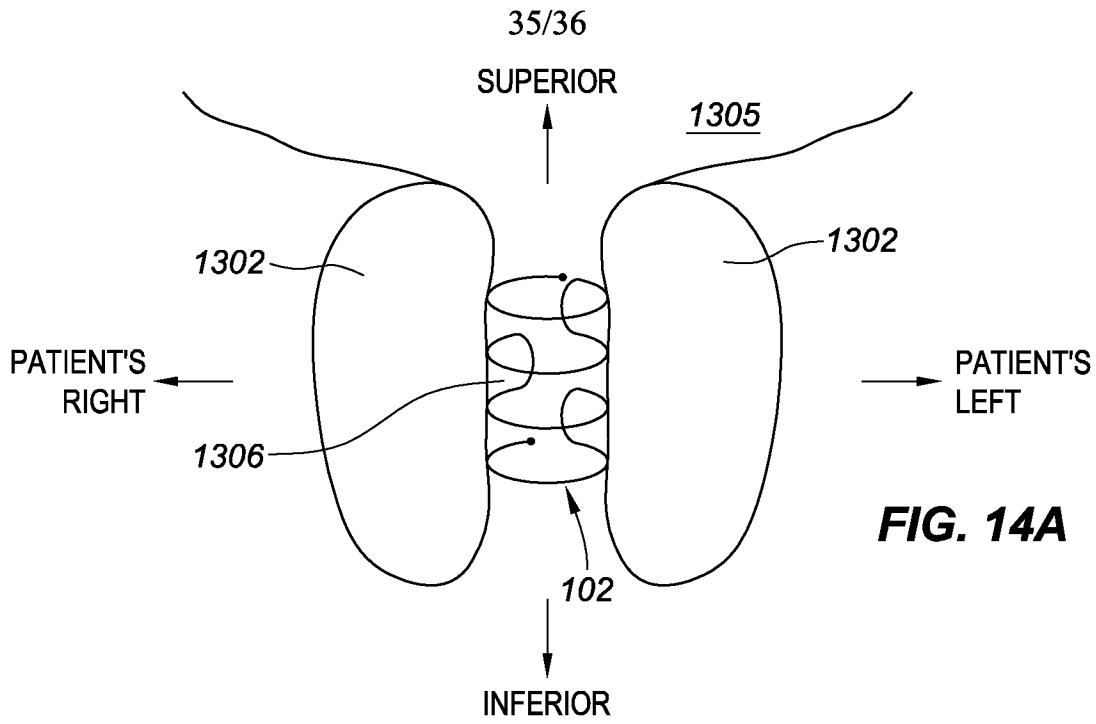
**FIG. 12D**



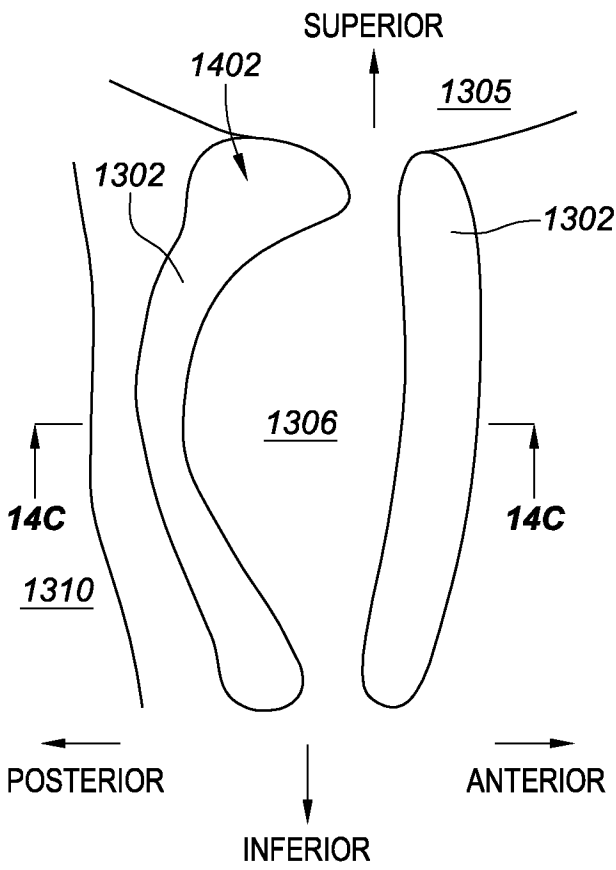
**FIG. 12E**



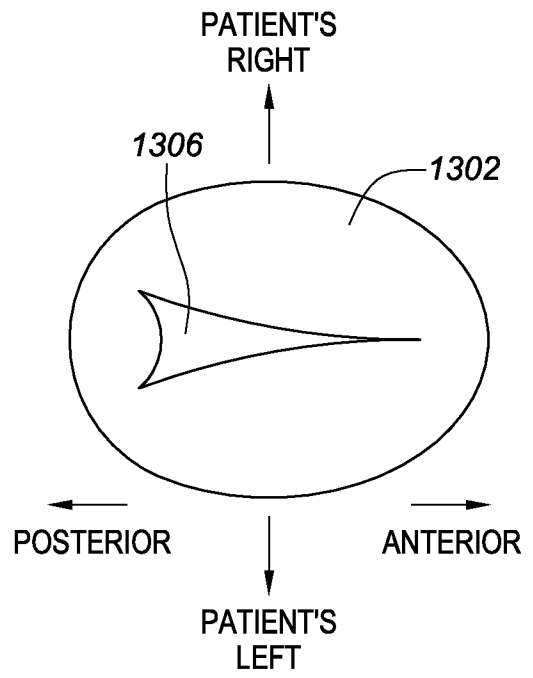
**FIG. 13**



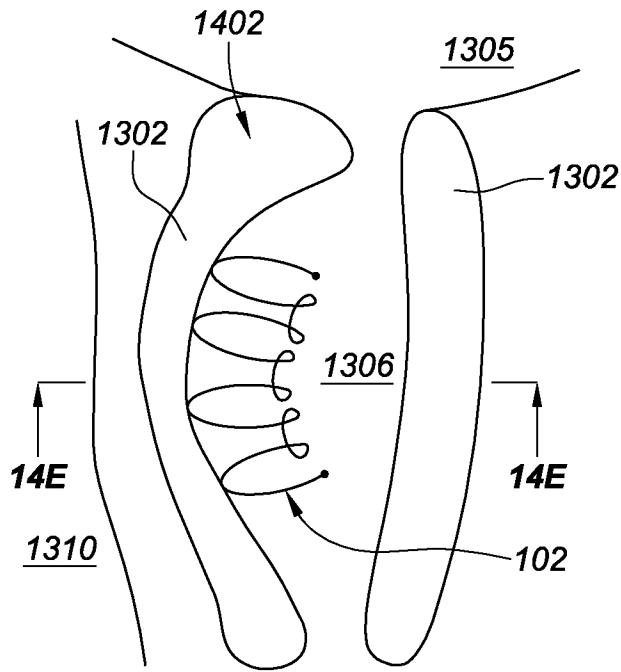
**FIG. 14A**



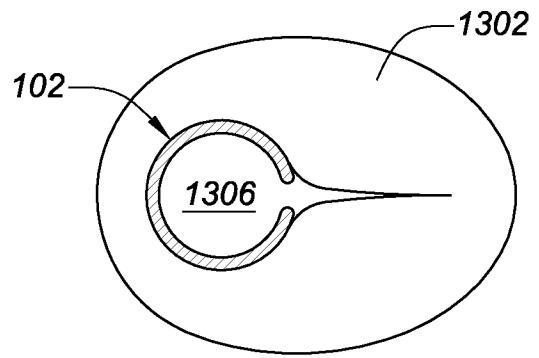
**FIG. 14B**



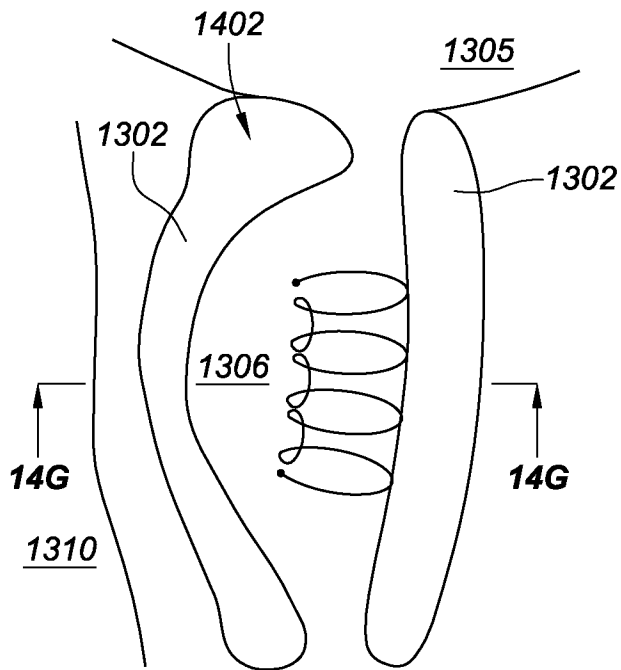
**FIG. 14C**



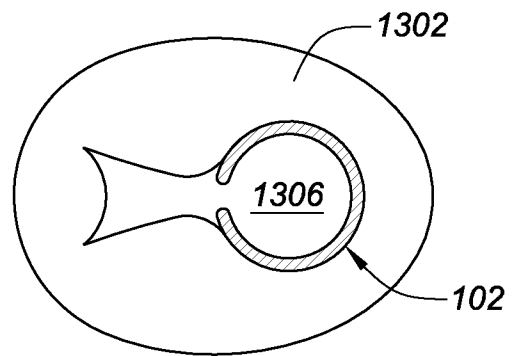
**FIG. 14D**



**FIG. 14E**



**FIG. 14F**



**FIG. 14G**