



(22) Date de dépôt/Filing Date: 2004/01/19  
 (41) Mise à la disp. pub./Open to Public Insp.: 2004/08/18  
 (45) Date de délivrance/Issue Date: 2011/03/15  
 (30) Priorité/Priority: 2003/02/18 (US10/369,331)

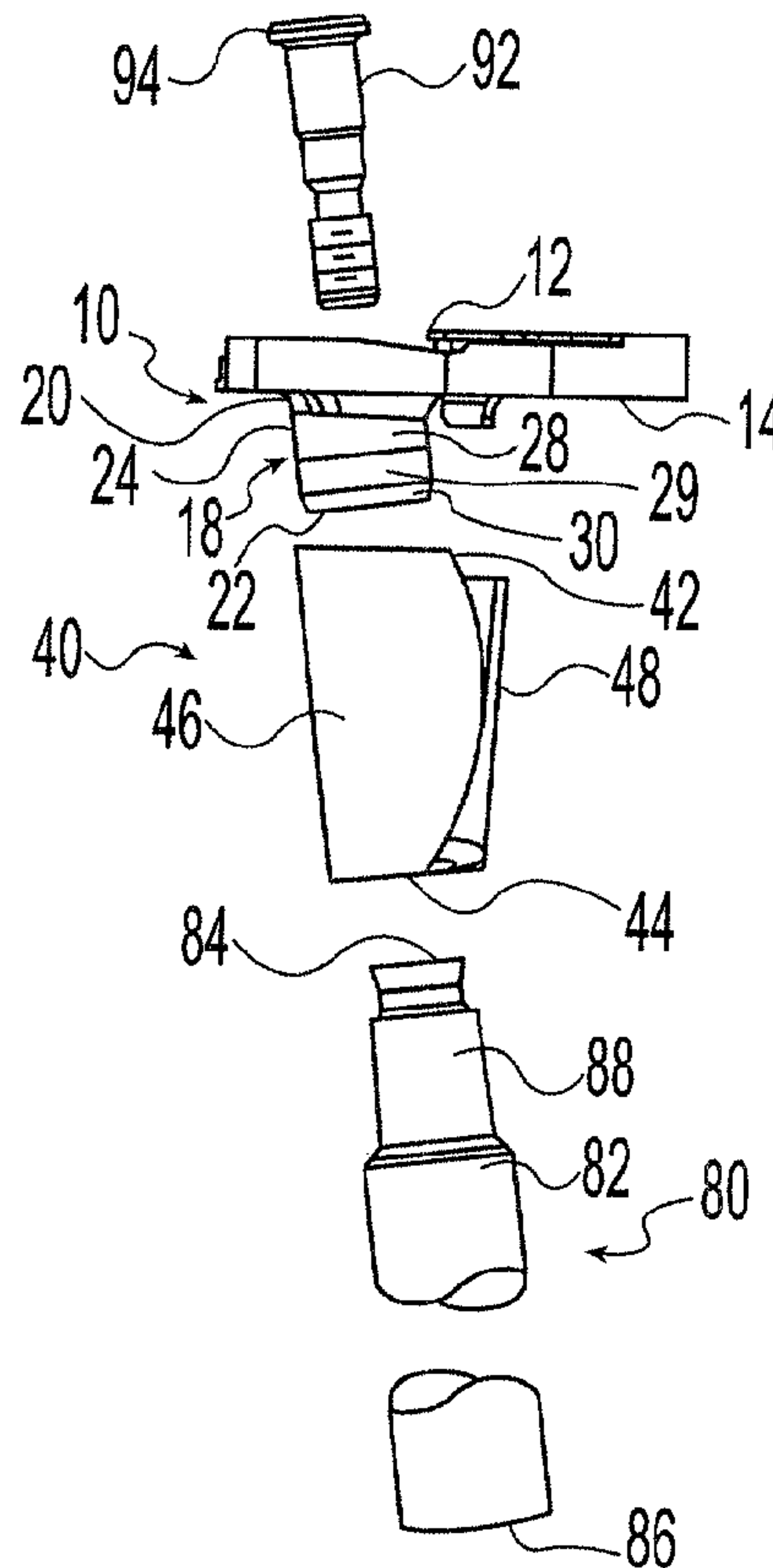
(51) Cl.Int./Int.Cl. *A61F 2/38* (2006.01),  
*A61F 2/28* (2006.01), *A61F 2/30* (2006.01),  
*A61F 2/46* (2006.01), *A61F 2/00* (2006.01)

(72) Inventeurs/Inventors:  
 HODOREK, ROBERT A., US;  
 BAKER, GORDON, US;  
 FALLIN, THOMAS WADE, US;  
 GERBEC, DANIEL, US;  
 ...

(73) Propriétaires/Owners:  
 ZIMMER TECHNOLOGY, INC., US;  
 BAKER, GORDON, US;  
 ...

(74) Agent: OGILVY RENAULT LLP/S.E.N.C.R.L.,S.R.L.

(54) Titre : GREFFON OSSEUX MODULAIRE, OUTIL ET METHODE  
 (54) Title: MODULAR BONE IMPLANT, TOOL, AND METHOD



(57) Abrégé/Abstract:  
 Modular bone implants , means of assembly, and their method of use are presented.

(72) **Inventeurs(suite)/Inventors(continued)**: GOBLE, E. MARLOWE, US; HAMMOND, NATHAN A., US;  
JUSTIN, DANIEL F., US; TRIPLETT, DANIEL J., US

(73) **Propriétaires(suite)/Owners(continued)**: FALLIN, THOMAS WADE, US; GERBEC, DANIEL, US;  
GOBLE, E. MARLOWE, US; HAMMOND, NATHAN A., US; JUSTIN, DANIEL F., US; TRIPLETT, DANIEL J., US

**ABSTRACT**

Modular bone implants , means of assembly, and their method of use are presented.

## **MODULAR BONE IMPLANT, TOOL, AND METHOD**

### 5 **CROSS-REFERENCE TO RELATED APPLICATIONS**

This application is a continuation-in-part of U.S. Application No. 10/132,668, filed April 25, 2002.

### **FIELD OF THE INVENTION**

10 The present invention relates to modular bone implants, means of assembly, and their method of use.

### **BRIEF DESCRIPTION OF THE DRAWINGS**

15 Various embodiments of the present invention will be discussed with reference to the appended drawings. These drawings depict only illustrative embodiments of the invention and are not to be considered limiting of its scope.

FIG. 1 is an exploded side elevation view of an illustrative embodiment of a bone implant according to the present invention.

20 FIG. 2 is a rear elevation view of the illustrative embodiment of FIG. 1.

FIG. 3 is a side sectional view of the illustrative embodiment of FIG. 1 taken along line 3-3 of FIG. 2.

FIG. 4 is a detail view of the sectional view of FIG. 3.

FIG. 5 is a bottom perspective view of the tray of the illustrative embodiment of  
25 FIG. 1.

FIG. 6 is a bottom plan view of the tray and keel of the illustrative embodiment of FIG. 1 assembled together.

FIG. 7 is a perspective view of an illustrative embodiment of an assembly tool according to the present invention.

5 FIG. 8 is a side sectional view of the illustrative embodiment of FIG. 7 showing the assembly tool in a condition ready for use.

FIG. 9 is a side sectional view of the illustrative embodiment of FIG. 7 showing the assembly tool after the first stage of its two stage activation.

10 FIG. 10 is a side sectional view of the illustrative embodiment of FIG. 7 showing the assembly tool during the second stage of its two stage activation.

### **DESCRIPTION OF THE ILLUSTRATED EMBODIMENTS**

The present invention is applicable to any bone implant in which modularity is  
15 advantageous. Examples include joint prostheses for the knee, hip, shoulder, elbow, ankle, and wrist. Such prostheses are implanted by first making an incision near the joint to access the joint space, cutting away the articulating bone ends to be replaced, and seating the prostheses on the cut bone ends. FIGS. 1-6 depict an illustrative tibial knee prosthesis used to describe the various aspects of the invention.

20 A tibial prosthesis 2 includes separate tray 10, keel 40, and stem 80 components able to be joined together to form a desired joint prosthesis configuration for replacing the articular surface of the proximal tibia. The tray 10 includes generally planar top 12 and bottom 14 surfaces. The top surface 12 is configured to receive a bearing surface (not shown), such as a polyethylene bearing surface, as is known in the art. The bottom  
25 surface 14 is configured to sit on the cut end of the proximal tibia. One or more fins 16

extend radially along the bottom surface and project downwardly from the bottom surface. The fins 16 are received in grooves cut in the proximal tibia to provide rotational resistance to the prosthesis. The fins 16 also serve to strengthen the tray 10 by increasing the bending moment of inertia of the tray. Where further stability is desired, the tray provides for the modular attachment of additional components via a boss 18 extending downwardly from the bottom surface 14. The boss 18 includes a top end 20 joined to the bottom surface 14 of the tray 10, a freely projecting bottom end 22, and an axis extending from the top end 20 to the bottom end 22. An outer wall 24 defines the exterior of the boss 18 and an inner bore 26 extends from the top end 20 to the bottom end 22. The outer wall includes a cylindrical mating portion 28, a tapered mating portion 30, and a relieved, non-mating portion 29 therebetween. An alignment hole 32 is formed in the bottom end 22 and extends upwardly between the outer wall 24 and the inner bore 26. The fins 16 can attach to the boss 18, or they can stop short of the boss 18 to leave a gap 34.

15 An extension can be mounted on the tray to increase the stability of the tibial prosthesis on the bone. Such an extension can take the form of a stem, a fluted stem, or a keel. The extension can be symmetric or asymmetric. In the illustrative embodiment, a keel 40 is mated to the boss 18 to increase both the rotational and bending stability of the tibial prosthesis on the bone. The keel 40 includes an elongate body having a top end 42 and a bottom end 44 with an axis extending between them, and an outer wall 46. The keel includes at least one fin 48 extending axially along the outer surface 46 and projecting radially outwardly. The keel includes a first axial bore 50 extending downwardly from the top end 42 and having a bore wall including a cylindrical mating portion 52, a tapered mating portion 54, and an end wall 56. An alignment hole 58 is formed in the end wall 56 and extends downwardly. The keel further includes a second

axial bore 64 extending upwardly from the bottom end 44 and comprising a tapered side wall 65. A keyed portal 66 communicates between the first 50 and second 64 axial bores. The portal 66 includes a circular central opening 67 and side slots 68 forming a bayonet engagable member. Alternately, the portal 66 can be threaded for engaging a threaded  
5 member..

The keel 40 engages the tray 10 with the boss 18 received in the first axial bore 50, the tapered portion 30 of the boss seating on the tapered portion of the bore 54, and the cylindrical portion 28 of the boss being received by the cylindrical portion 52 of the bore in press-fit relationship to form a junction between the tray 10 and keel 40. The  
10 tapered portions aid in aligning the components as they are brought together. The cylindrical press-fit locks the components together. The cylindrical press-fit also provides a fluid tight seal to prevent material from migrating past the press-fit into or out of the junction. In the illustrative embodiment, the relieved portion 29 of the boss results in a circumferential gap 69 between the boss 18 and first axial bore 50 lying between the  
15 cylindrical 28, 52 and tapered 30,54 portions of the junction. The tray 10 and keel 40 can be aligned by providing an alignment pin 70 in one of the alignment holes 32, 58. In the illustrative embodiment, the keel alignment hole is slightly smaller than the pin 70 and the pin 70 is pressed into it. The tray alignment hole 32 is slightly larger than the pin. As the components are brought together, they are prevented from seating until the tray  
20 alignment hole 32 engages the pin 70. Where a gap 34 exists between the boss 18 and fins 16, the top end 42 of the keel 40 can extend further up and fit into the gap 34 as shown in FIG. 4.

The junction of the present invention makes use of a press-fit which is advantageous over Morse taper-type arrangements used alone. The press fit allows the  
25 components to slide together in tight frictional engagement to create a fluid-tight seal and

strong resistance to dislocation. The practicalities of machining result in a press-fit having a band, or area, of contact whereas a taper typically has line contact between the mating parts. The press-fit therefore provides a better seal and is more likely to prevent material from migrating across the press-fit boundary. Furthermore, the press-fit locking arrangement is not dependent on precise axial positioning between the components and therefore allows them to be positioned axially at a desired location, once initial press-fit engagement has been achieved. While a cylindrical press fit has been shown and lends itself to precise manufacturing, other cross-sectional shapes can be used in a sliding press-fit according to the invention. The junction also utilizes a taper engagement which provides for centering of the components during assembly and a positive stop to seating as the tapered portions bottom on one another. When the taper is fully seated, it provides increased bending strength to the junction due to the axial distance between the press fit and taper contacts. As shown in FIG. 4, the press-fit 28, 52 and tapered 30,54 portions are spaced apart axially as far as possible to maximize the bending strength of the junction. The illustrative taper is greater than  $3^\circ$  to facilitate manufacturing of a taper with a predictable seating depth. However, the taper can be a locking taper to provide further locking strength. Because the press-fit permits continued axial translation during assembly after it is engaged, the tapered portion of the junction can be locked after the press-fit has been engaged. A locking taper would be on the order of  $1.5-3^\circ$ .

When assembled, the tray 16 and keel 48 fins are generally aligned with one another from top to bottom to project as a single fin, as best seen in FIG. 6. However, when the tray and keel are fully assembled, there remains an axial gap 72 between the fins 16, 48 so that they do not touch. In the illustrative embodiment, the first axial bore is arranged with the cylindrical press fit portion 52 above the tapered portion 54 and locking pin 70. With this arrangement, and the axial spacing 72 of the fins 16, 48, there is no

contact between the tray 10 and keel 40 outside of the junction. Any particles that may be produced by contact between the components are sealed in the junction so that they cannot migrate upward into the joint space. While it is within the scope of the invention to form the tapered portions above the cylindrical portions to provide the centering and locking functions, such an arrangement does not provide the same sealing characteristics.

A stem 80 can be combined with the tray 10 and keel 40 assembly to provide further bending stability to the tibial prosthesis. The stem 80 includes a shaft 82 having a top end 84 and a bottom end 86. The top end 84 includes a tapered portion 88 and an axial threaded bore 90. The tapered portion 88 of the stem is received in the second axial bore 64 of the keel 40. This taper joint can also be provided as a self locking taper. A bolt 92 extends through the inner bore 26 of the boss and the portal 66 and threads into the threaded bore 90 of the stem to draw and hold the components together. The head 94 of the bolt is recessed into a counter bore 96 formed in the top surface 12 of the tray.

The invention further comprises an assembly tool for assembling modular joint components requiring a linear biasing force during assembly. The assembly tool is particularly well suited where high assembly forces are required. It is also well suited for a minimally invasive approach to the joint where an assembly force needs to be delivered to a small remote surgical space. The press-fit arrangement of the illustrative modular implant embodiment requires from 1000 to 2000 pounds of assembly force depending on the amount of interference between the press-fit components. For example, a 0.001 inch interference has been found to require 1000 pounds and a 0.002 inch interference has been found to require 2000 pounds. Likewise, when the components are positioned for assembly, it has been found that 0.050 inches of displacement are required to remove slack from the assembly and another 0.100 inches of displacement to fully engage the components.

FIGS. 7-10 depict an illustrative embodiment of an assembly tool capable of providing the force and displacement required for assembling the illustrative modular implant. A compressor 100 includes a handle 102 having proximal 101 and distal 103 ends, a first shaft member 104 having a mounting end 106 rigidly attached to the handle and a working end 108, and a second shaft member 110 coaxially mounted within the first shaft member for axial translation relative to the first shaft member 104. The second shaft member includes a first end 112 and a second end 114. The first end 112 includes an engagement tip 116 such as a threaded tip or a bayonet tip. The illustrative embodiment comprises a T-shaped bayonet tip 116 having a round central portion 118 and a pair of ears 120 extending radially outwardly. The bayonet tip 116 is generally the same shape as the portal 66 in the keel 40 and can be attached to the keel by inserting it into the portal 66 and rotating the second shaft member 110 one-quarter turn relative to the keel so that the ears 120 extend beyond and grip the underside of the portal 66. A linear motor is located inside the handle 102 and is connected to the second end 114 of the second shaft member 110 in axial force transmitting relation. The motor stores energy until it is needed to assemble the modular joint components. When activated, the motor causes the second shaft member 110 to translate toward the handle and thus the bayonet 116 tip to move toward the working end 108 of the first shaft member 104.

In use, the modular joint components are initially engaged with the boss 18 received within the axial bore 50. The first 104 and second 110 shaft members are inserted along the inner bore 26 until the bayonet tip 116 of the second shaft member 110 extends through the portal 66. The tool is rotated so that the ears 120 extend underneath the edges of the portal 66. At this point, the bayonet tip 116 positively engages the keel 40 and the working end 108 of the first shaft member 104 rests against the bottom of the counter bore 96. The motor is actuated and the second shaft is withdrawn to draw the tray

10 and keel 40 into locking engagement. The tool 100 is then rotated until the ears 120 again align with the portal 66 and the tool is withdrawn.

A variety of motor mechanisms can be provided to generate the linear motion to operate the tool 100. Examples include electric and pneumatic rotary motors coupled  
5 with rotary-to-linear transmissions, linear pneumatic pistons, and spring mechanisms. The illustrative embodiment depicts a linear spring motor comprising twenty Belleville washers 130 constrained by a telescoping core 132. First 134 and second 136 motion blocks abut opposite ends of the stack of washers 130. Absent other constraints, the first and second motion blocks 134, 136 and washers 130 are free to translate axially within  
10 the handle 102. The second shaft member 110 extends through the second motion block 136 and telescoping core in axial sliding relationship. The second end 114 of the second shaft member 110 is coupled to the first motion block 134 such that the second shaft member 110 moves with the first motion block 134. An axial opening 137 communicates from the exterior to the interior of the handle in alignment with the first motion block  
15 134. The opening 137 permits a ram attached to an external press to be inserted into the handle 102 to press against the first motion block 134 to compress the mechanism.

A linkage comprising a pair of links is positioned at each end of the handle to provide positive capture and release of the two motion blocks. The distal linkage comprises a first link 138 and a second link 140 pinned together 139 for rotation relative  
20 to one another. The first link is pinned at its opposite end to the first motion block 134 for rotation relative to the first motion block 134. The second link is pinned 135 at its opposite end to the distal end 103 of the handle for rotation relative to the handle. The linkage is prevented from aligning at the point of singularity along its pivot axes, or top dead center, by a tang 142 projecting from the second link 140 to contact a pin 144 in the  
25 handle. The tang 142 and pin 144 stop counter clockwise rotation of the linkage 2° before

reaching the point of singularity. A first locking pin 146 slides in a bore 148 in the side of the handle 102 to engage a cam 150 on the second link 140 to releasably block the linkage from rotating clockwise. Due to the shallow angle of the linkage in this position, large axial forces on the motion block impart relatively small forces against the locking pin 146. A similar linkage comprising a pair of links 152, 154 is pinned to the proximal end 101 of the housing and second motion block 136. This linkage is similarly restrained against over rotation by a tang 156 and pin 158 and is releasably blocked by a second locking pin 162 sliding in a bore 164.

A trigger mechanism 170 is provided to simplify the sequential operation of the two locking pins 146, 162. A trigger housing 172 is mounted on the handle 102 and supports the other parts of the mechanism. A first lever 174 is pinned 178 for rotation in the housing 172 and includes an input end 173 and an output end 175. The output end 175 is connected to the first locking pin 146 via a yoke 182 surrounding a ball end 184 formed on the locking pin 146. The input end 173 of the first lever 174 is biased upwardly by a leaf spring 186, thereby biasing the locking pin 146 downwardly into engagement with the cam 150. The first lever pivot pin 178 is nearer the output end 175 so that there is a mechanical advantage proportional to the ratio of the input and output lengths. Therefore, forces applied at the input end 173 are multiplied to ease manipulation of the locking pin 146. Similarly, the second lever 176 is pinned 180 for rotation in the housing 172 and includes an input end 187 and an output end 188. The output end 188 is connected to the second locking pin 162 via a yoke 190 surrounding a ball end 192 formed on the locking pin 162. The input end 187 of the second lever 176 is biased upwardly by a leaf spring 194, thereby biasing the locking pin 162 downwardly into engagement with the cam 160. A trigger 196 is pinned 198 for rotation in the trigger housing 172 and overlies the input ends 173, 187 of the two levers 174, 176. The trigger

196 includes a first contact 200 projecting downwardly to engage the input end 173 of the first lever 174. The trigger 196 includes a second contact 202 projecting downwardly to engage the input end 187 end of the second lever 176. The second contact 202 is spaced, relative to the first contact 200, so that it does not activate the second lever 176 until after  
5 the first lever 174 has been fully activated.

In use, the assembly tool 100 is held with its distal end down so that gravity moves the second motion block 136 axially downwardly toward the center of the mechanism. As the second motion block 136 moves, the proximal linkage rotates clockwise with the end of the second locking pin 162 riding on the cam 160. When the  
10 linkage is straightened to its limits, the locking pin 162 slips over the end of the cam 160 and snaps into position to lock the second motion block 136. The first motion block 134 is now axially pressed toward the center of the mechanism with an external press to compress the washers 130. As the first motion block 134 moves, the distal linkage rotates counterclockwise with the end of the first locking pin 146 riding on the cam 150. When  
15 the linkage is straightened to its limits, the pin 146 slips over the end of the cam 150 and snaps into position to lock the first motion block 134. The precharged assembly tool is now in condition to be used to assemble the modular joint components. The tool 100 is engaged with the implant components. The trigger 196 is pressed to activate the tool. As the trigger 196 rotates about its pivot pin 198, the first contact 200 presses the input end  
20 173 of the first lever 174 causing the output end 175 to withdraw the first locking pin 146 and release the distal linkage. The distal linkage rotates clockwise and permits the first motion block 134 to spring distally. The second shaft member 110 moves with the first motion block 134 and draws the modular components together. The spring action of the tool snaps the press-fit junction into engagement. With the first motion block 134  
25 released, the remaining spring tension still exceeds the minimum required to seat the

press-fit junction. This ensures that the junction is fully seated but makes it difficult to disengage the tool 100 from the joint components. Therefore, continued pressing of the trigger causes the second contact 202 to press against the input end 187 of the second lever 176 to withdraw the second locking pin 162. This permits the second motion block  
5 136 to spring proximally and release the remaining spring tension. The tool 100 can now be disengaged from the joint components. The two stage trigger release happens quickly and is transparent to the user who is simply required to fully depress the trigger once to cause the separate sequential releases.

In clinical use, an incision is made in the knee joint. For a minimally invasive  
10 surgical approach according to the present invention, an incision is made on one of the medial and lateral sides of the knee joint to expose the joint surfaces while avoiding compromising the soft tissue of the suprapatellar pouch. Next, resection instruments are introduced through the incision to prepare the proximal tibial bone and form a keel receiving recess. Ideally, only the minimum amount of bone required to provide a stable  
15 flat surface on the tibia is removed. The illustrative modular tibial component has a low profile. Because of this low profile and modularity, the incision can be quite small and need only be large enough to allow passage of the individual components. The present investigators have found that a tray component having an overall height less than 18mm can be inserted through such a minimally invasive surgical incision and engage the tibia  
20 where the minimum amount of bone has been removed. The keel component of the present invention can be manipulated into the prepared joint space because it lacks the large top surface of the tray. Likewise, the low profile and modularity of the components permit the patella to remain in its anatomic orientation relative to the femur to further reduce the trauma experienced by the joint during surgery and aid recovery and ultimate  
25 outcome from the procedure. The keel is manipulated through the incision and placed

into the recess. The tray is then manipulated through the incision and engaged with the keel. The assembly instrument is engaged with the tray and keel and activated to draw the components together to engage the press-fit and seat the tapered portions of the modular junction.

5           It will be understood by those skilled in the art that the foregoing has described illustrative embodiments of the present invention and that variations may be made to these embodiments without departing from the spirit and scope of the invention defined by the appended claims. The various aspects of the present invention are applicable to a variety of bone implants in addition to the illustrative tibial implant. Likewise, where  
10 male/female engaging portions have been depicted, the male and female components may be reversed and still be within the anticipated scope of the invention. Likewise the arrangement of the multiple incongruous junction shapes can be changed while keeping within the invention. For example, the illustrative embodiment depicts a junction including a press-fit and then a taper. The invention contemplates reversing that order so  
15 that the taper comes before the press-fit.

CLAIMS:

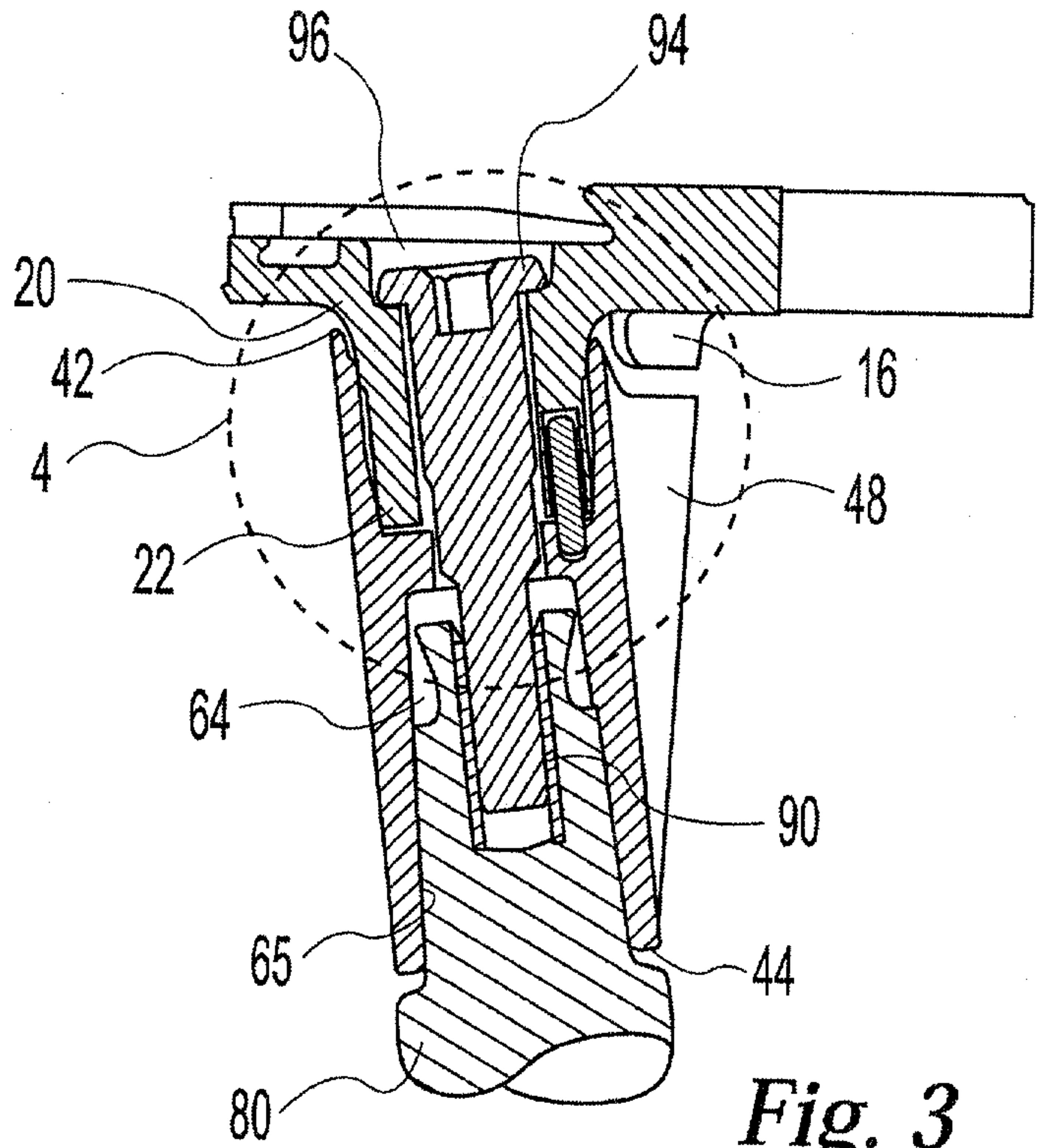
1. A tibial component of a knee prosthesis comprising a tray having substantially planar top and bottom surfaces and an extension forming an elongate body having a top end and a bottom end, one of the tray and extension including an outwardly projecting boss, the boss has an outer wall including a cylindrical portion and a tapered portion, the other of the tray and extension include an inwardly extending bore forming a bore wall, the bore wall including a cylindrical portion and a tapered portion, the extension being removably engagable with the tray with the boss received in the bore, the tapered portion of the boss seating on the tapered portion of the bore and the cylindrical portion of the boss being received by the cylindrical portion of the bore, wherein the cylindrical portions are received in press-fit relationship to form a junction between the tray and extension, the tray and extension being spaced from one another everywhere except at the cylindrical and taper seating portions of the junction, characterised in that the boss is relieved between the cylindrical and tapered portions so that there is clearance between the boss and bore between the cylindrical and tapered portions.
2. The tibial component of claim 1, wherein the tapered portions form a locking taper.
3. The tibial component of claim 1 or 2, wherein the boss extends downwardly from the bottom surface of the tray and the bore comprises a first axial bore formed in the extension extending from the top end toward the bottom end of the extension.
4. The tibial component of claim 1, 2 or 3, wherein the tapered portion of the boss is formed below the cylindrical portion of the boss and the tapered portion of the bore is formed below the cylindrical portion of the bore so that the tapered seating portion of the junction is below the cylindrical press-fit portion of the junction.
5. The tibial component of any one of claims 1 to 4, wherein the cylindrical press-fit between the boss and first axial bore seals the bore to prevent material from entering or leaving the portion of the bore below the press-fit.

6. The tibial component of any one of claims 1 to 5, wherein the tray further comprises at least one fin extending along the bottom surface and projecting downwardly from the bottom surface and the extension further comprises at least one fin projecting outwardly, the fins being generally aligned with one another from top to bottom to project as a single fin but being in axial spaced relationship so that they do not contact.
7. The tibial component of any one of claims 1 to 6, wherein the tibial component further comprises rotational alignment means for aligning the extension and tray in a predetermined relationship for assembly, the alignment means being formed within the junction.
8. The tibial component of claim 7, wherein the rotational alignment means is positioned within the junction relative to the cylindrical press-fit portion so that it is sealed within the junction to prevent migration of material from the rotational alignment means outside of the junction.
9. The tibial component of claim 7, wherein the rotational alignment means comprises a pin received in a hole.
10. The tibial component of claim 9, wherein the pin is located in the first axial bore and the pin is received by a hole formed in the boss.
11. The tibial component as claimed in any one of claims 1 to 10, wherein the extension comprises a keel and includes a second axial bore extending from the bottom end toward the top end to communicate with the first axial bore, the second axial bore forming a tapered inner wall for receiving a stem extension.
12. The tibial component of claim 11, wherein the tray includes a bore extending from the top surface downwardly through the boss in communication with the first axial bore, the tray bore receiving a bolt in engagement with one of the keel and stem extension.
13. The tibial component of any one of claims 1 to 12, wherein at least one of the tray and extension components includes at least one fin.

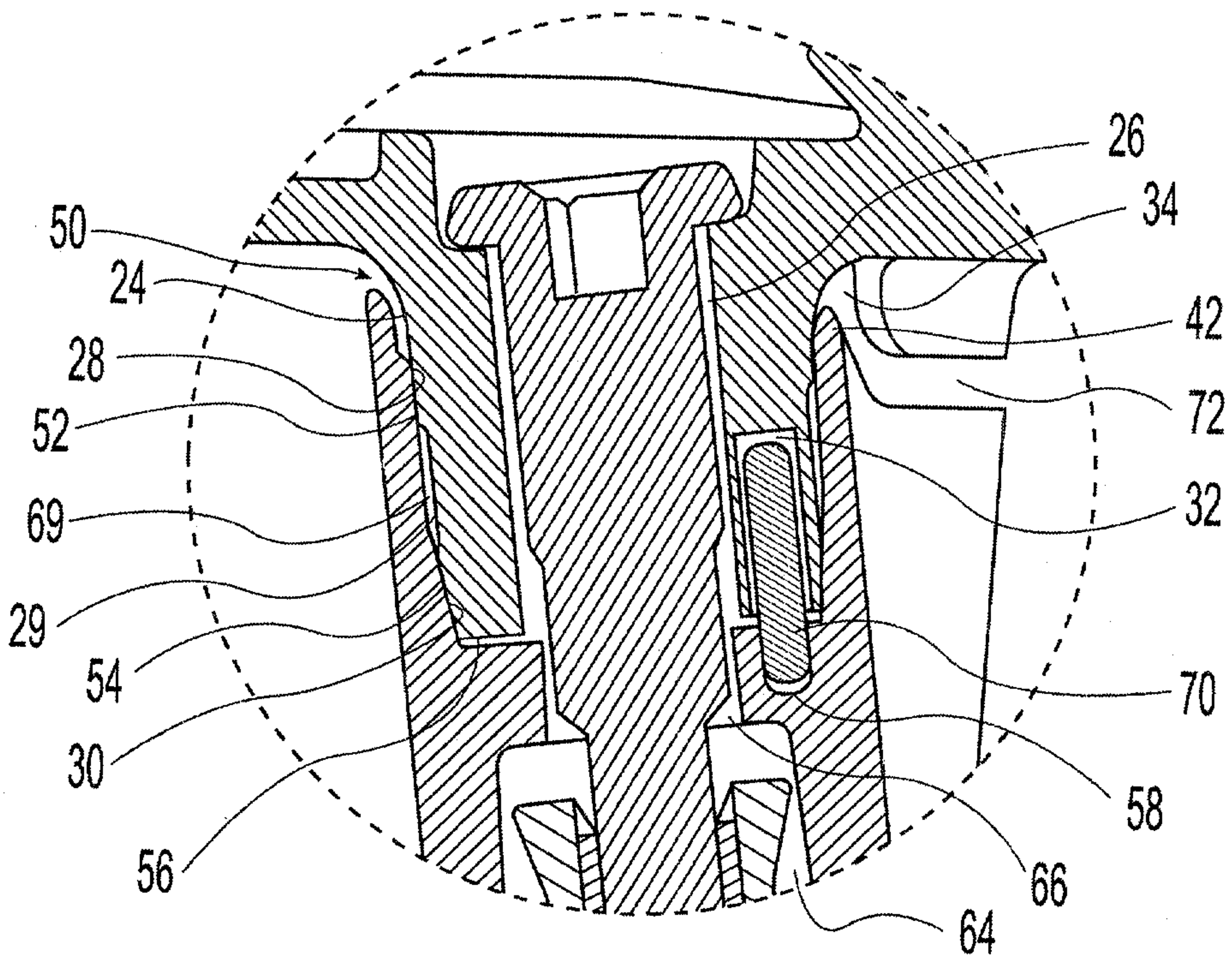
14. The tibial component of any one of claims 1 to 13, wherein the tray includes at least one fin extending radially along its bottom surface and projecting downwardly and the keel includes an outer surface and at least one fin extending axially along the outer surface and projecting radially outwardly, the fins on the tray and keel aligning from top to bottom to project as a single fin, the fins on the tray and keel being axially spaced from one another.



2/5

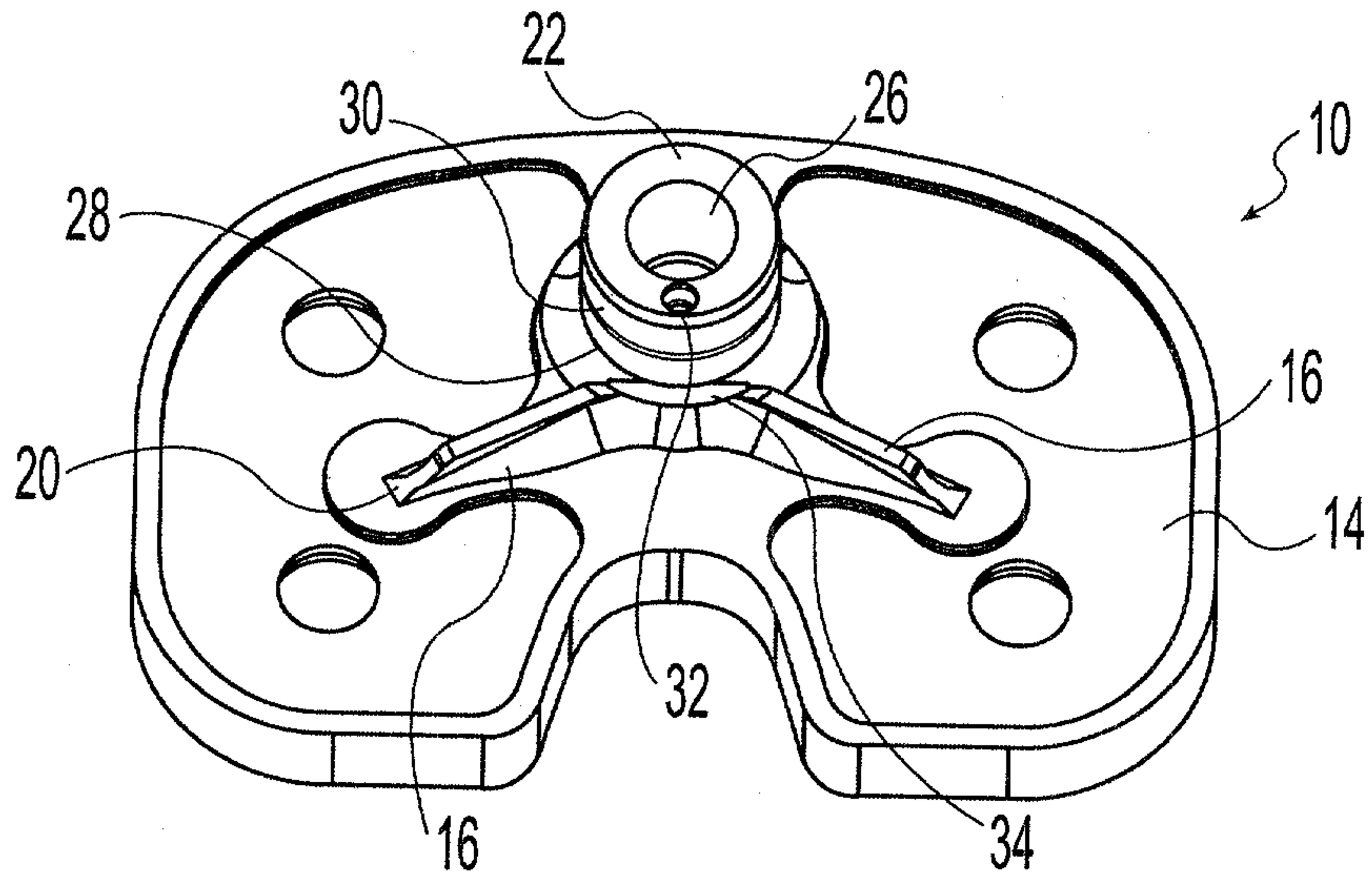


*Fig. 3*

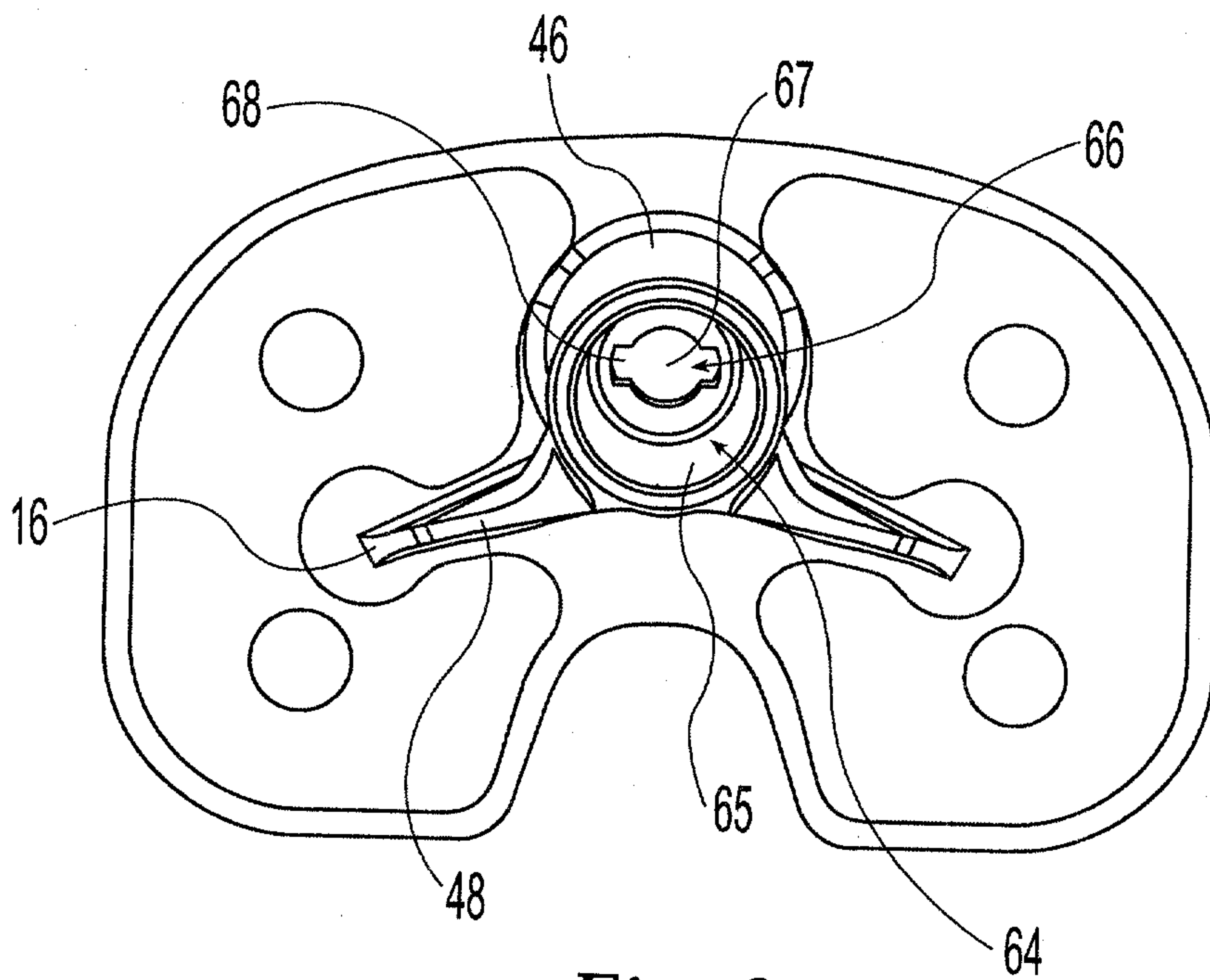


*Fig. 4*

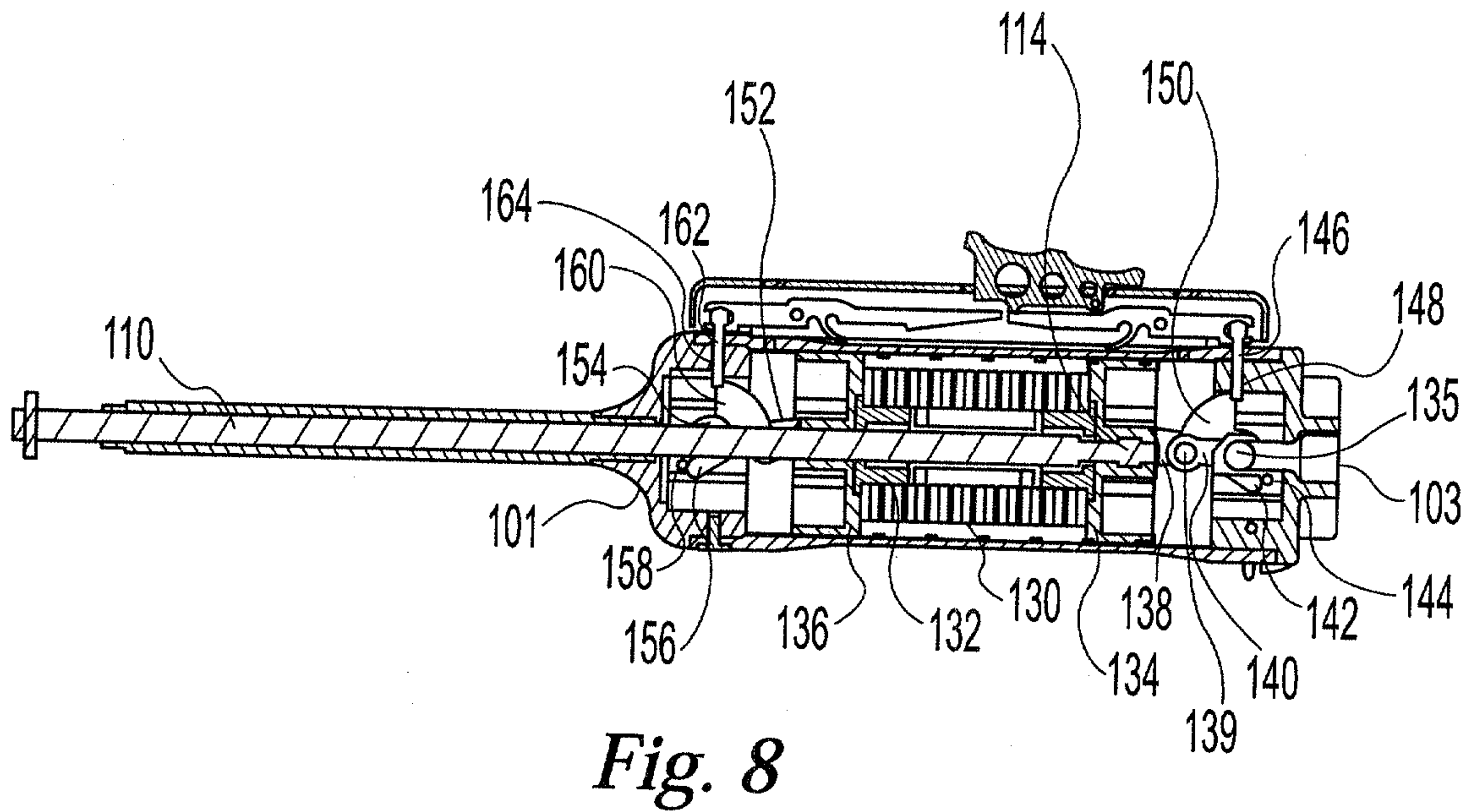
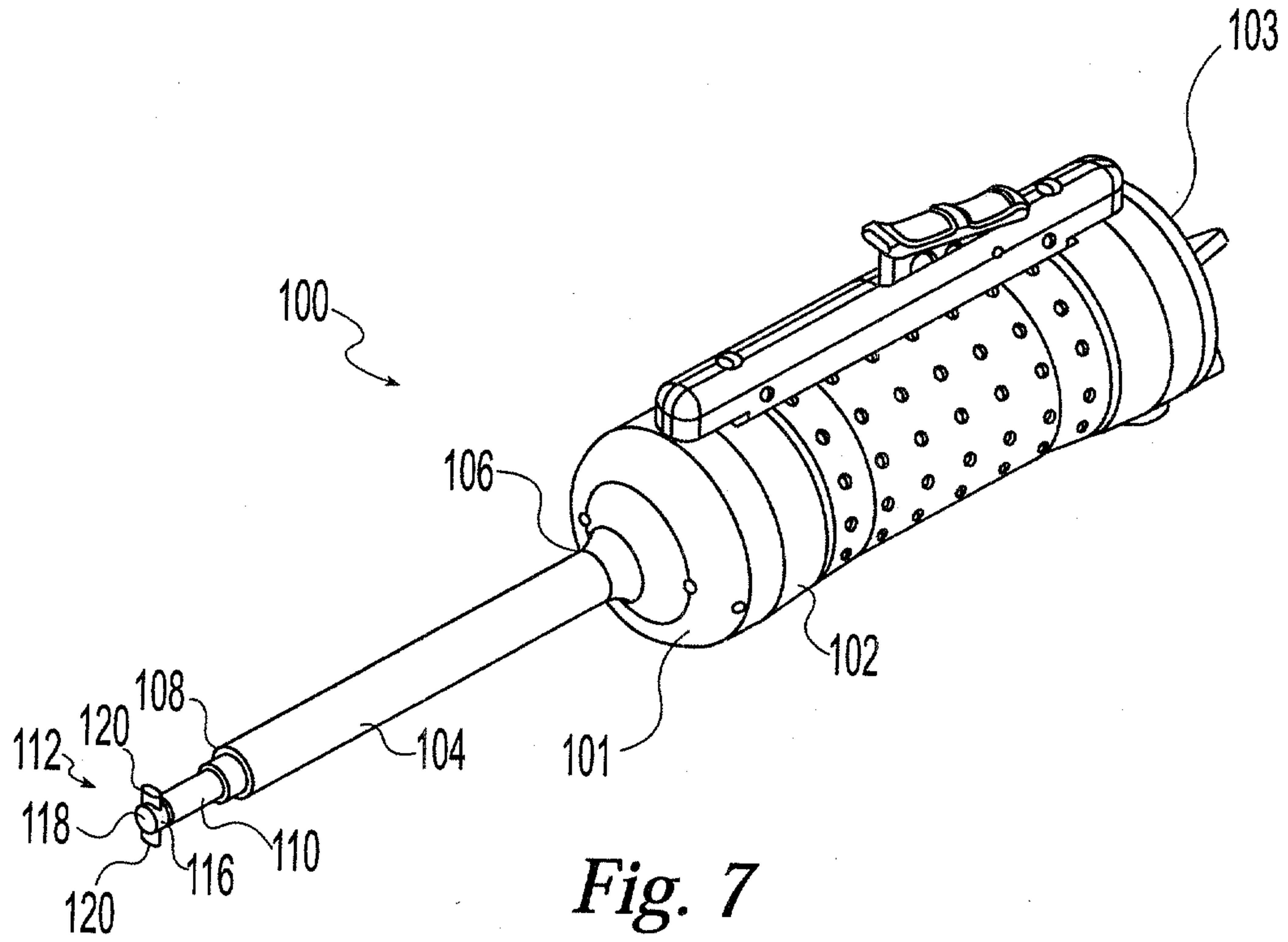
3/5



*Fig. 5*



*Fig. 6*



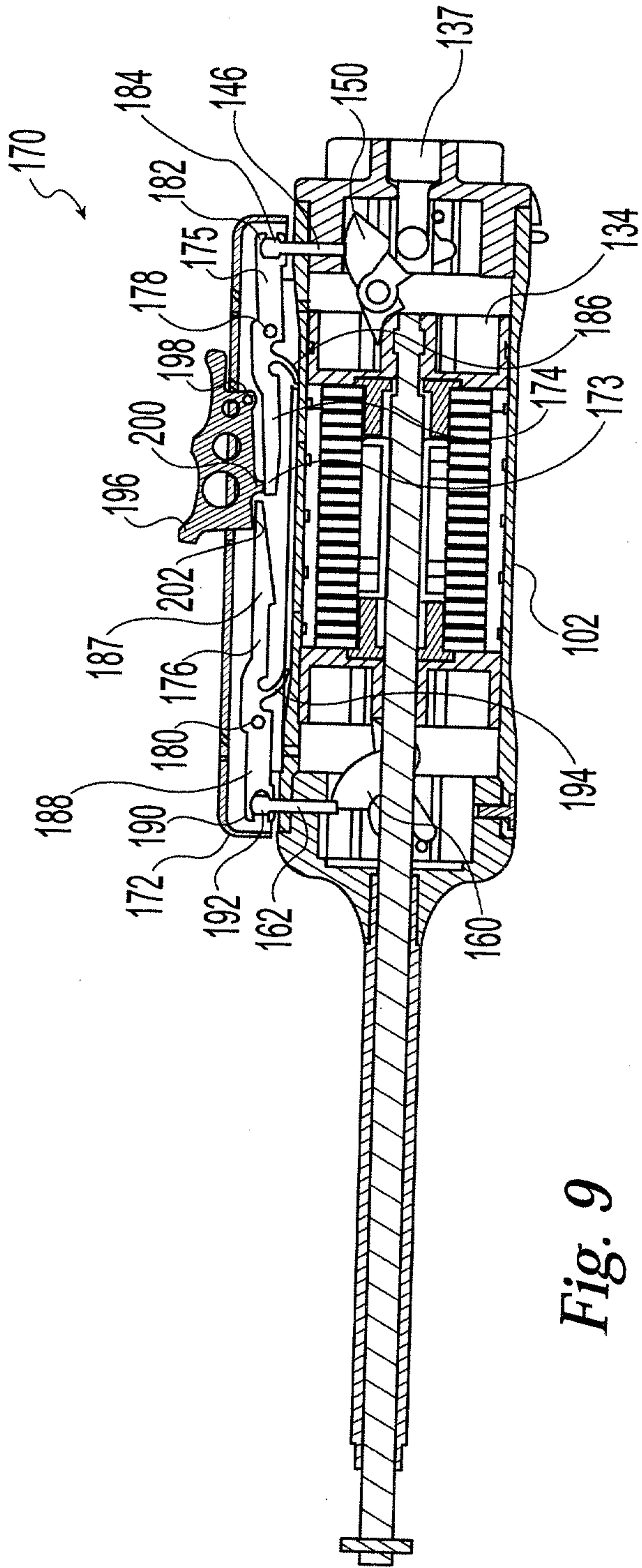


Fig. 9

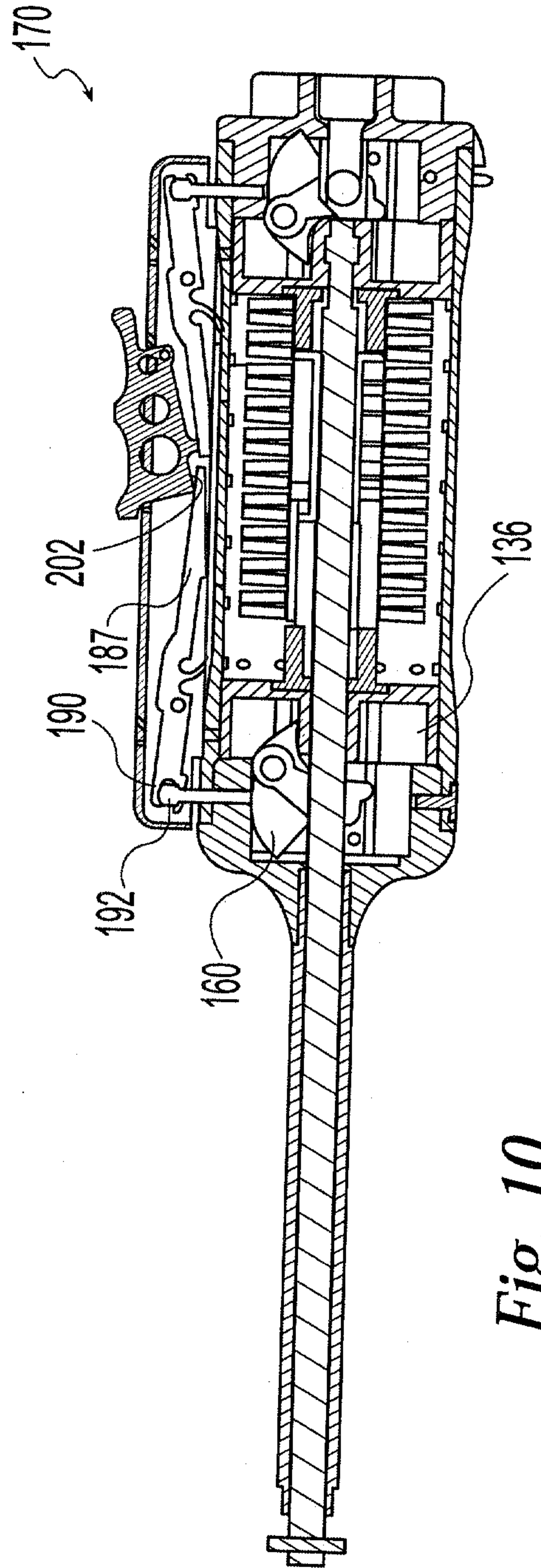


Fig. 10

