

W. F. KNELL.
CONTROLLING VALVE FOR AIR BRAKE SYSTEMS.

APPLICATION FILED AUG. 21, 1902.

NO MODEL.

2 SHEETS—SHEET 1.

Fig. 1

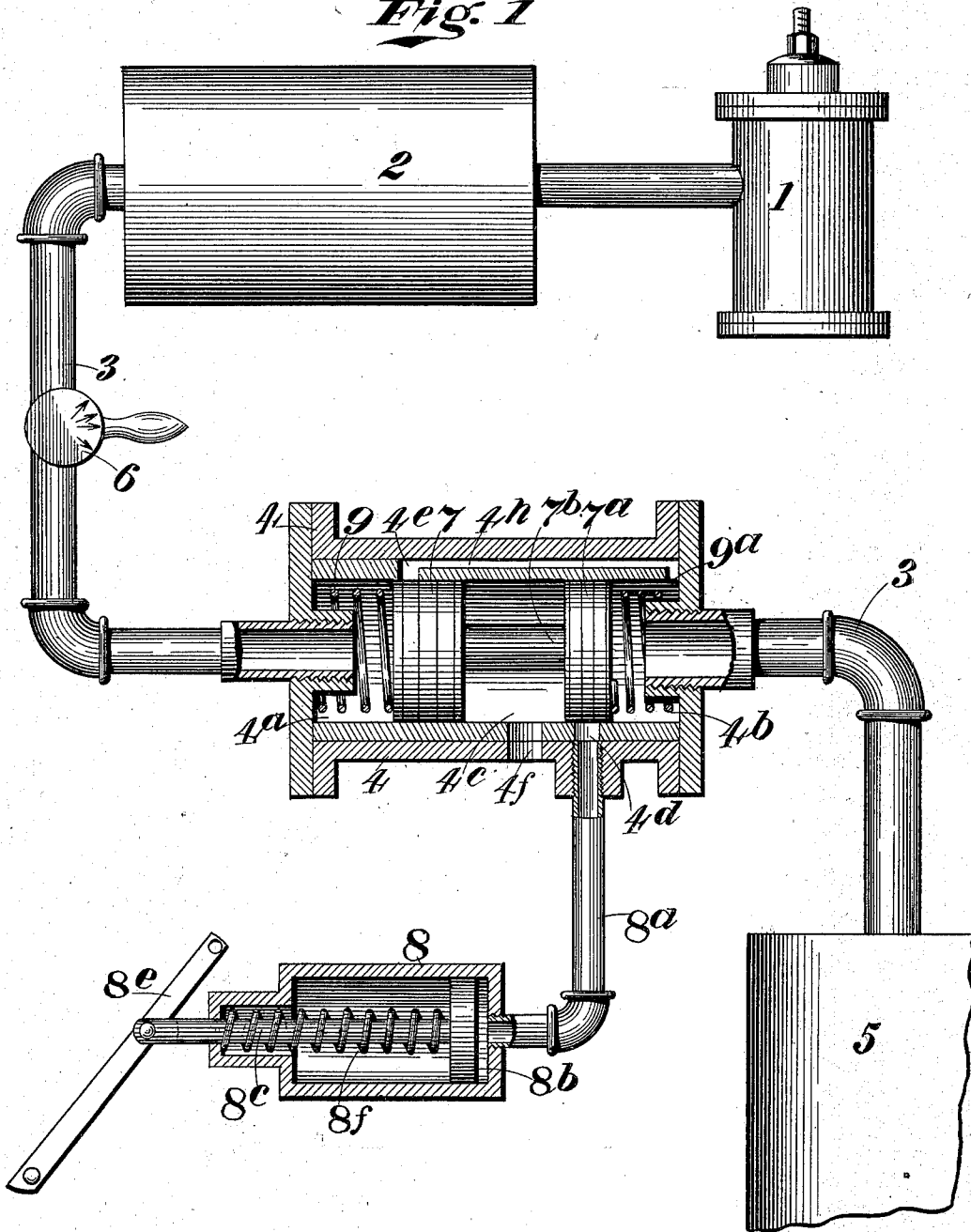

WITNESSES:

C. Edward Haffey
James P. Mansfield

INVENTOR,

By: *William F. Knell*
Alexander & Towle
Attorneys.

W. F. KNELL.
CONTROLLING VALVE FOR AIR BRAKE SYSTEMS.

APPLICATION FILED AUG. 21, 1902.

NO MODEL.

2 SHEETS—SHEET 2.

Fig. 2

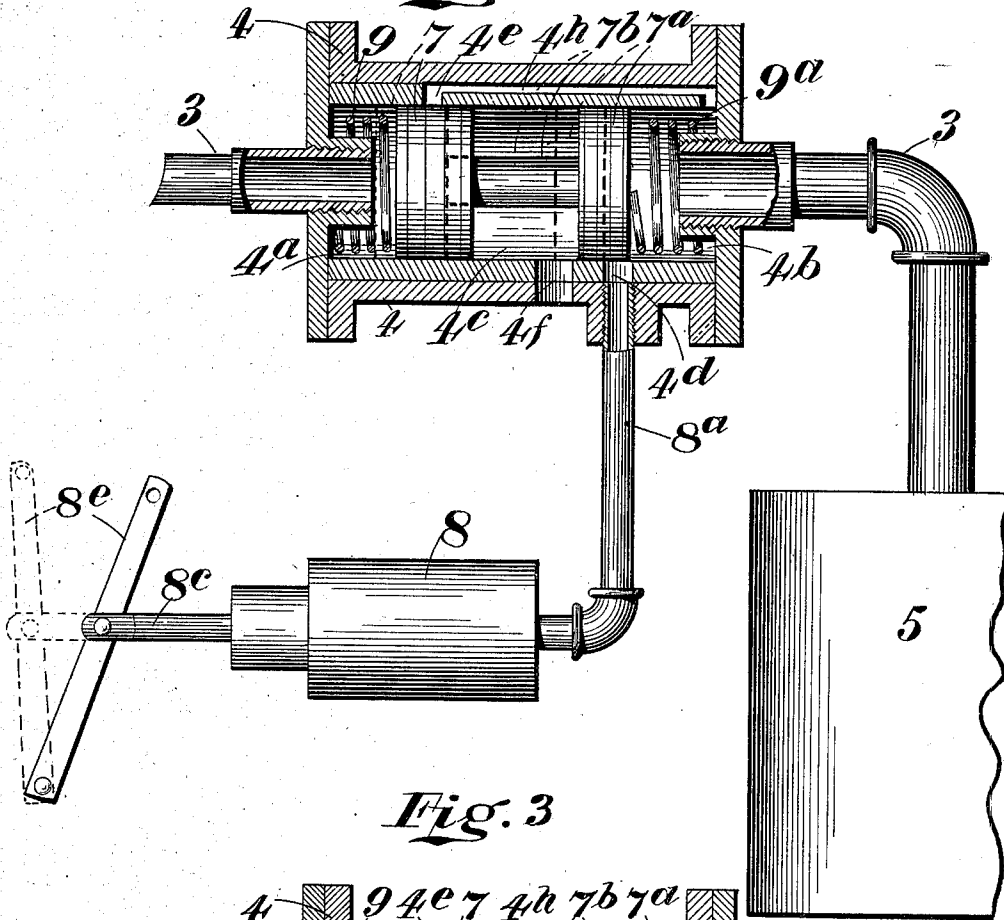
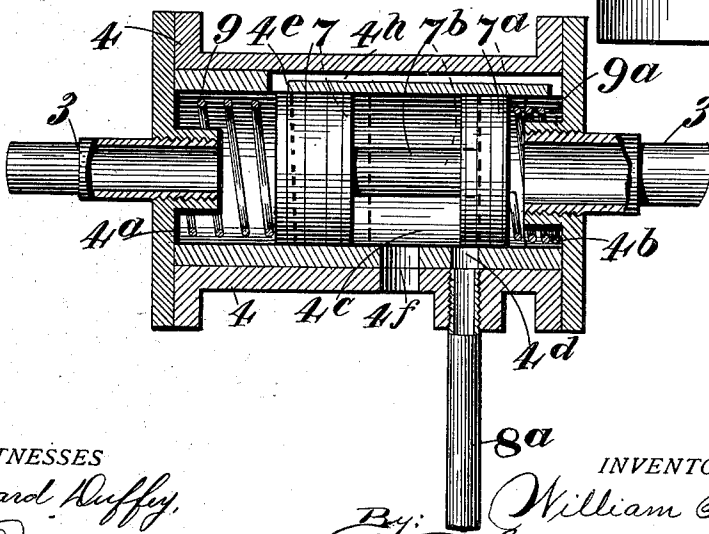

Fig. 3



WITNESSES

C. Edward Ruffey,
James D. Mansfield

INVENTOR

By: William F. Knell
Alexander & Sowell
Attorneys

UNITED STATES PATENT OFFICE.

WILLIAM FRANKLIN KNELL, OF BATTLECREEK, MICHIGAN, ASSIGNOR TO
EUGENE L. MARKEY, RICHARD R. HICKS, NEIL I. PHELPS, AND ABRAM
C. WISNER, OF BATTLECREEK, MICHIGAN.

CONTROLLING-VALVE FOR AIR-BRAKE SYSTEMS.

SPECIFICATION forming part of Letters Patent No. 733,051, dated July 7, 1903.

Application filed August 21, 1902. Serial No. 120,444. (No model.)

To all whom it may concern:

Be it known that I, WILLIAM FRANKLIN KNELL, of Battlecreek, in the county of Calhoun and State of Michigan, have invented
5 certain new and useful Improvements in Controlling-Valves for Air-Brake Systems; and I hereby declare that the following is a full, clear, and exact description thereof, reference being had to the accompanying drawings,
10 which form part of this specification.

This invention is an improvement in air-brakes; and it consists in a novel valve for automatically controlling the passage of air, as follows: first, from the main to the auxiliary reservoir; second, from the auxiliary reservoir to the brake-cylinder, and, third, from the brake-cylinder to the atmosphere, the valve being particularly designed to enable the brakes to be applied and released
20 either gradually or rapidly, as the case may require, and also to enable the brakes to be partially applied or partially released and held so applied or partially released with any desired degree of pressure; also, to maintain pressure in the auxiliary reservoir by preventing waste of air and unnecessary venting of the brake-cylinder and to so construct the valve that air will be admitted and stored in the auxiliary reservoir whenever
30 the brake-cylinder is even partially vented, the valve being constructed to admit air to the auxiliary reservoir before or simultaneously with any reduction in the brake-pressure, or, in other words, every partial release
35 of brake is accompanied by an increase of pressure in the auxiliary reservoir. The controlling-valve piston is automatically controlled by the compressed air or other active fluid, which is regulated by a suitable hand-
40 operated valve located at any desired point on the train, car, or engine, between the main reservoir and the controlling-valve casing.

Another object of the invention is to reduce the number of working parts in the automatic
45 controlling-valve and simplify the construction thereof, so that it can be manufactured with little labor and expense, while at the same time it shall be efficient, reliable, and sensitive in its operation.

50 The invention therefore consists in the

novel automatic controlling-valve as herein-
after claimed and which is hereinafter described in detail with reference to the accompanying drawings, which illustrate what I consider the best and simplest form of such
55 valve now known to me; but I do not wish to be restricted to the specific construction and dimensions of the parts of the valve illustrated in the drawings.

In said drawings, Figure 1 is a diagrammatical view of a complete air-brake mechanism, the controlling-valve being shown in section, with the pistons in normal position closing all the ports. Fig. 2 is a diagrammatic view of the brake-cylinder, auxiliary
60 air-reservoir, and controlling-valve, the latter being shown in section, with the pistons in dotted lines in positions assumed when the brake is applied for emergencies, and also showing the pistons in full lines in the positions assumed for a partial or retarding
65 application of the brake. Fig. 3 is a sectional view of the controlling-valve with the pistons in full lines in the positions assumed when partially releasing brake, and in dotted
70 lines the positions assumed when fully releasing brakes.

The main reservoir 2 is supplied with air from an air-compressor 1 of any desired construction and is connected with the auxiliary reservoir 5 by a pipe or pipes 3.
80

Between the main reservoir and the auxiliary reservoir between lengths of pipe 3 is inserted the controlling-valve casing 4, and between the controlling-valve 4 and the main
85 reservoir 2 is the motorman's or engineer's brake-valve 6, by which the passage of air from the main reservoir to the controlling-valve and from the controlling-valve to the atmosphere is regulated. I do not herein
90 claim the construction of the engineer's brake-valve, and therefore it is unnecessary to show or explain the same in detail herein, as there are a number of valves on the market which could be used for the purpose stated. 95

The controlling-valve comprises a cylindrical casing 4, which, as shown, is axially in alignment with the sections of pipe 3 connected therewith; but the direct passage of air through this casing is prevented by the
100

valve-pistons 7 and 7^a, which are connected by a stem 7^b. These valve-pistons divide the interior of the casing into three chambers—to wit, 4^a and 4^b, respectively, at the opposite ends thereof and an intermediate chamber 4^c between the pistons 7 and 7^a. A port 4^e opens into the side of the chamber 4^a and is opened and closed by piston 7. Said port 4^e connects with a passage 4^h, which extends through the wall of casing 4 and connects with the other chamber 4^b, so that when the piston-valves are in the positions shown in Fig. 3 air can pass from the chamber 4^a around the pistons, through the port 4^e and passage 4^h, to the chamber 4^b, in this way establishing direct communication between the main reservoir 2 and the auxiliary reservoir 5 if the brake-valve 6 in pipe 3 is properly shifted. In the wall of the casing 4, adjacent to the chamber 4^b, is a port 4^d, which is connected by a pipe 8^a with the brake-cylinder 8. The port 4^d is controlled by the piston 7^a. When this piston 7^a is in either position shown in Fig. 2, communication is established between the brake-cylinder 8 and the auxiliary reservoir 5 through the chamber 4^b. Consequently the brake will be applied. When the piston 7^a is in the positions shown in Fig. 3, communication is established between the port 4^d and the chamber 4^c, and from this latter chamber leads an exhaust-port 4^f, so that when the piston 7^a is in the positions shown in Fig. 3 the brake-cylinder will be vented through port 4^d, chamber 4^c, port 4^f, and pipe 8^a to the atmosphere.

The brake-cylinder may be of any suitable construction and ordinarily contains a piston 8^b, connected by a rod 8^c to the brake-lever 8^e, the piston being normally returned to release the brake by means of a spring 8^f.

When the pistons 7 7^a are in the position shown in Fig. 1, which is their normal position, both ports 4^e and 4^d are closed, the former by piston 7 and the latter by piston 7^a.

When the piston 7 is in either position shown in Fig. 2, port 4^e remains closed, but port 4^d is partly or wholly open, the brakes being applied and the air retained in the auxiliary reservoir. When piston 7 is in either position indicated in Fig. 3, air will be admitted from the main reservoir to the auxiliary reservoir.

In order to insure the return of the pistons to their normal position (shown in Fig. 1) when the pressure in the main reservoir and the auxiliary reservoir becomes equal, as hereinafter explained, light springs 9 and 9^a may be placed in the chambers 4^a and 4^b and between the heads of the cylinder and the adjacent pistons, such springs being so adjusted that they will return the pistons to and normally maintain them in the central position. I do not, however, limit myself to the employment of these springs.

The pistons 7 7^a are so constructed and distanced relative to the ports 4^e and 4^d that the instant the piston 7 uncovers port 4^e (when moving to the right) piston 7^a also uncovers

port 4^d, permitting the brake-cylinder to exhaust.

When the pistons move to the left, piston 7 closes port 4^e before piston 7^a opens port 4^d, and piston 7 keeps port 4^e closed when piston 7 moves sufficiently to the left to uncover port 4^d and admit air to the brake-cylinder.

Operation: When the air is admitted from the main reservoir 2 into pipe 3, it passes through same to the chamber 4^a in casing 4 and forces the pistons 7 7^a back, opening port 4^e, and passes therethrough to the opposite chamber 4^b and thence into the auxiliary reservoir 5, charging the latter with same pressure as in the main reservoir 2—say sixty pounds. As soon as the flow of air stops and the pressure becomes equal in both reservoirs the pistons 7 7^a move back and piston 7 covers port 4^e and the piston 7^a closes port 4^d, as shown in Fig. 1. The brake is then ready for use. When the brake is to be applied, the pressure in the pipe 3 is reduced by means of valve 6. This causes the pistons 7 7^a to move toward the left and open port 4^d, allowing air in the auxiliary reservoir 5 to pass into the brake-cylinder 8 and set the brake. To release the brake, the air in the main reservoir is allowed to pass into the pipe 3 and chamber 4^a, raising the pressure therein above that in the chamber 4^b and auxiliary reservoir, whereupon pistons 7 7^a move to the right, piston 7^a uncovering port 4^d from the inside and allowing the air in the brake-cylinder to exhaust through chamber 4^c and port 4^f, thus releasing the brake. As the pressure is normally the same in both reservoirs 2 and 5, a slight reduction of pressure in the train-pipe 3 will cause the pistons 7 7^a to move enough to the left to allow a little air to pass through port 4^d into the brake-cylinder; but as soon as enough air has passed to brake-cylinder to lower the pressure in the auxiliary reservoir equal to that in pipe 3 the pistons 7 7^a will move back, and the latter will close port 4^d, holding the air in brake-cylinder 8, which cannot escape until the pressure in the train-pipe is raised sufficiently to force pistons 7 7^a back far enough to the right to allow the air to escape through chamber 4^c into the atmosphere. After the brakes have been set should it be desired to partially release them it can be done by slightly reducing the pressure in the brake-cylinder, as follows: Air is admitted from the main reservoir into pipe 3 through valve 6 sufficient to cause a slight increase of pressure in chamber 4^a against piston 7. This will cause pistons 7 and 7^a to move to the right and barely open ports 4^e and 4^d, which will result in simultaneously releasing a small portion of the air from the brake-cylinder and at the same instant admitting more air to the auxiliary reservoir and slightly increasing the pressure therein; but as soon as the pressure becomes equal in reservoir 5 to that in pipe 3, which is almost instantly, (or equal in chambers 4^a and 4^b,) the pistons will move back to normal position

85

90

95

100

105

110

115

120

125

130

135

140

145

150

155

160

165

170

and close ports 4^a and 4^e, retaining the brake applied, but with less pressure. Thus every time the pressure on the brake-cylinder is lessened additional air is stored in the auxiliary reservoir, so that whenever the brake-cylinder is vented and while it is venting additional air is admitted to and stored up in the auxiliary reservoir. Whenever the air-pressure in the auxiliary reservoir equals that in the pipe 3, the pistons move back to normal position, piston 7^a covering port 4^d and holding any balance of air in the brake-cylinder. In the meantime the pressure in auxiliary reservoir has been increased to give sufficient power for an emergency stop, if required, before the brakes have been entirely released.

By the use of this valve the air-brake can be set and released gradually at the will of the operator by causing intermittent or successive slight increases of pressure in the train-pipe, while the pressure in the auxiliary reservoir is augmented each time the brake-pressure is lessened, whereas brakes operated by the ordinary triple valves cannot be released partially, for when released at all they are released entirely, and the pressure in the auxiliary reservoir must be restored before brakes can be properly set again.

By means of the valve described the brakes are entirely controllable and may be applied and held applied with greater or less pressure at the will of the motorman or engineer. They may be applied powerfully and quickly in case of emergency and be released either instantly or partially, and if the brakes should have been applied too tightly they can be eased without entirely releasing them and always with an accompanying increase of pressure in the auxiliary reservoir, thereby enabling the motorman or engineer to keep his train always under control and to vary the brake-pressure at will.

By slightly increasing the pressure in train-pipe after the brakes have been set the engineer can ease the brakes by partially releasing them. By a full increase of pressure in train-pipe he can instantly and fully release the brakes. By slightly reducing pressure in train-pipe he can partly apply the brakes, and by fully venting the train-pipe he can apply the brakes hard and instantly in emergencies. Whenever the brakes are released, however, additional air passes to the auxiliary reservoir, so that air is being stored therein for use during the venting of brakes. No complicated mechanism is required and no by-pass pipes or valves used, all the operations being automatically controlled by the simple valve shown and as above described. The engineer can always have his train under full control and with sufficient air to operate the brakes, never having to wholly release brakes in order to reduce their pressure and never wholly losing the supply of air in the auxiliary reservoir, which can only vent into the brake-

cylinder, and at no time can it vent into the brake-cylinder when the latter is in communication with atmosphere.

Having thus described my invention, what I therefore claim as new, and desire to secure by Letters Patent thereon, is—

1. In combination, the main and auxiliary reservoirs, the brake-cylinder, and the brake-valve, of an air-brake apparatus; with a controlling-valve automatically controlled by the air-pressure in the train or service pipe and adapted to admit air from the main to the auxiliary reservoir as and when the brake-cylinder is vented, and to gradually reduce the pressure in brake-cylinder correspondingly with any increase of pressure in the service-pipe, and means to return the valve to normal position, substantially as described.

2. In an air-brake apparatus; the combination of the main and auxiliary reservoirs, the train or service pipe therebetween, the brake-cylinder, and the brake-valve in the train-pipe; with a controlling-valve in the train-pipe, between the brake-valve and auxiliary reservoir, connected with the brake-cylinder, and controllable by varying the air-pressure in the train-pipe, said valve being adapted to gradually reduce the pressure in the brake-cylinder upon slight repeated increases of pressure in the service-pipe, and to simultaneously admit air from the train-pipe into the auxiliary reservoir as the brake-pressure is lowered and means to return the valve to normal position, substantially as described.

3. In combination with the main and auxiliary air-reservoirs, the service-pipe, the brake-valve therein, and the brake-cylinder; an automatic valve interposed between the auxiliary reservoir and brake-cylinder, said automatic valve comprising chambers respectively communicating with the service-pipe and the auxiliary reservoir; a port communicating with the brake-cylinder, a port for establishing communication between the valve-chambers, connected pistons respectively governing said ports, and an exhaust-port between the pistons, said pistons and ports being so related that when pressure is lessened in the service-pipe air is admitted from the auxiliary reservoir to the brake-cylinder, and the brakes may be gradually released by intermittently slightly increasing the pressure in the service-pipe, and means to return the valve-pistons to normal position, substantially as described.

4. In combination with the train-pipe, the auxiliary reservoir and brake-cylinder, of a pneumatic air-brake system, a controlling-valve casing having two chambers respectively communicating with the train-pipe and the auxiliary reservoir, and an intermediate port communicating with the atmosphere, a port and passage connecting the two chambers, a port connecting the chamber next the auxiliary reservoir with the brake-cylinder; and a pair of connected pistons in said valve, one piston controlling the communication be-

tween the end chambers, and the other the communication between the brake-cylinder and auxiliary reservoir, and the brake-cylinder and atmosphere, said pistons and ports 5 being so related that air is admitted to the auxiliary reservoir as and when the brake-cylinder is vented and by repeatedly slightly increasing the pressure in the service-pipe the pressure in the brake-cylinder can be gradually 10 reduced until the pressure in the train-pipe and auxiliary reservoir is equalized, and means for returning the valve-pistons to normal position when the pressure is equalized, substantially as described.

15 5. In combination, the main reservoir, the auxiliary reservoir, the pipe connections between the reservoirs, and the brake-valve in said pipe; with the controlling-valve interposed between the brake-valve and auxiliary 20 reservoir, said controlling-valve having a port and channel for the passage of air around the valve-pistons; an outlet-port, and a port connected with the brake-cylinder, and connected 25 pistons adapted to control the several ports, whereby upon reducing pressure in the train-pipe the brake is applied, and by intermittently slightly increasing pressure in train-pipe the brake-pressure may be gradually reduced, air being admitted to the auxiliary res- 30 ervoir each time the brake-pressure is reduced, and means for returning the pistons to normal position, substantially as described.

35 6. In an air-brake apparatus, the combination of the main and auxiliary reservoirs, the train-pipe connection therebetween, a brake-valve in said pipe, and a brake-cylinder; with a controlling-valve interposed in the train-pipe between the brake-valve and auxiliary

reservoir, said valve having opposite end chambers respectively communicating with 40 the train-pipe and the auxiliary reservoir, a port connecting the auxiliary-reservoir chamber with the brake-cylinder, a port and by-pass connecting the two chambers, a pair of connected 45 pistons respectively controlling said ports; and an exhaust port and chamber between the pistons; said pistons and ports being so related that upon lessening the pressure in the train-pipe the by-pass is closed and the port to brake-cylinder opened, partially 50 or wholly according to the pressure in train-pipe, and upon increasing pressure in train-pipe the pistons are moved so as to close communication between the auxiliary reservoir 55 and brake-cylinder, establish communication between the main and auxiliary reservoirs, and also establish communication between the brake-cylinder and atmosphere, only so long as there is an excess of pressure in the 60 train-pipe, whereby the brake-pressure may be gradually lessened or quickly released at the will of the engineer, and during the venting of brake-cylinder the auxiliary reservoir is being charged, said pistons being returned to normal position closing the brake-cylinder 65 port and by-pass port whenever the pressure in the train-pipe and auxiliary reservoir is equalized.

In testimony that I claim the foregoing as my own I affix my signature in presence of two 70 witnesses.

WILLIAM FRANKLIN KNELL.

In presence of—

E. L. MARKEY,
GEO. E. WILSON.