

(19) **DANMARK**

(10) **DK/EP 3018979 T3**



(12) **Oversættelse af  
europæisk patentskrift**

Patent- og  
Varemærkestyrelsen

- 
- (51) Int.Cl.: **H 05 B 37/02 (2006.01)** **H 04 L 12/64 (2006.01)** **H 04 W 24/04 (2009.01)**
- (45) Oversættelsen bekendtgjort den: **2019-04-15**
- (80) Dato for Den Europæiske Patentmyndigheds bekendtgørelse om meddelelse af patentet: **2019-02-27**
- (86) Europæisk ansøgning nr.: **14192580.0**
- (86) Europæisk indleveringsdag: **2014-11-10**
- (87) Den europæiske ansøgnings publiceringsdag: **2016-05-11**
- (84) Designerede stater: **AL AT BE BG CH CY CZ DE DK EE ES FI FR GB GR HR HU IE IS IT LI LT LU LV MC MK MT NL NO PL PT RO RS SE SI SK SM TR**
- (73) Patenthaver: **Schreder, Rue de Lusambo 67, 1190 Bruxelles, Belgien**
- (72) Opfinder: **Schröder, Helmut, Tulpenweg, 16, 65201 Wiesbaden, Tyskland**  
**Brand, Daniel, Hildegardisstrasse, 6, 50735 Köln, Tyskland**  
**Wellens, Didier, Bloemenlaan, 52, 1950 Kraainem, Belgien**
- (74) Fuldmægtig i Danmark: **Plougmann Vingtoft A/S, Strandvejen 70, 2900 Hellerup, Danmark**
- (54) Benævnelse: **Fremgangsmåde til drift og udvidelse af et netværk af lygter**
- (56) Fremdragne publikationer:  
**WO-A1-2015/000803**  
**US-A1- 2011 215 735**  
**US-A1- 2012 147 604**  
**US-A1- 2013 057 158**  
**US-A1- 2013 057 181**



## DESCRIPTION

**[0001]** The present invention relates to a method for operating, particularly for controlling, and expanding a network of lights, in which case the lights are in particular street lights.

**[0002]** Networks of lights are equipped with increasingly intelligent control systems. For instance, networks of lights can be operated by telemanagement systems, in which a device known as segment controller, which is connected to a management console on a PC, controls a number of lights via their control module. The segment controller, which is too large to be integrated into a light, must be set up such that the lights to be controlled can communicate with the controller via a short-distance communication module. A failure of the segment controller leads to a control failure of the light network.

**[0003]** There is also the method of equipping all light control modules of the network to be controlled with a long-distance communication module, for instance a GSM-based module, which the control modules use to communicate with a central server. Due to the large number of control modules actively integrated into a provider or long-distance communication network, relevant communication expenses arise when this network is used.

**[0004]** Furthermore, the commissioning/start-up of new lights within these known systems is costly, as particularly the GPS-supported allocation of the controller to a light must be carried out manually. Finally, the latency in the network is comparatively high due to the large number of lights controllable by a segment controller.

**[0005]** US2012/147604 A1 discloses a network of lights wherein controllers function to interface with and control features and functions of lamp heads. The controllers also include communication and GPS capability so that they can communicate with a central entity and so that the exact geographic location of the lamp heads can be determined. The lamp heads include one or more antennas that are used to provide wireless communication using cellular, WiFi, Bluetooth or other communication technology.

**[0006]** WO2015/000803 A1 describes a communication network of an outdoor lighting network. The network comprises a network controller and a plurality of lamps each controlled by a communication device, the communication device comprising a GPS module, a memory and a transceiver. The transceiver comprises a first (long-range) telecommunication module and a second (low-range) telecommunication module. The communication device is adapted to transmit GPS information, link quality, neighbours identities or count to the network controller.

**[0007]** The invention described herein aims to create a method for operating and expanding a light network, which is easier to start up, guarantees improved system stability and is furthermore cheaper to operate.

**[0008]** The task is solved by a method described in claim 1 as well as a system described in

claim 29. Advantageous embodiments of the invention are described in the sub-claims referring to the above-mentioned claims as well as the following description.

**[0009]** The method according to this invention facilitates operation of a more stable and less costly light network with a simplified installation process. The method according to this invention makes use of multiple control modules, each of which is allocated or is to be allocated to one light and each of which is equipped with a long-distance communication module (e.g. GSM, GPRS, Iridium or another cellular network or an Ethernet connection), a short-distance communication module (ZigBee, 6 LoWPAN or similar), preferably a near field communication module (especially with a near field sensor), a geocoordinates module to determine the position of the control module based on GPS, GLONASS Galileo or other in particular satellite based positioning systems, a controller, preferably at least one sensor and additionally a control output (e.g. on a DALI or 0 resp. 1 to 10 volt basis). The control output can transmit control signals to a driver of an illuminant of the light, preferably a street light.

**[0010]** Furthermore, the network is equipped with at least one server to be reached via the long-distance communication module. A suitable software for telemanagement can run on this server. For operating the network, the control modules are divided into one or more groups of control modules, with this division being based on information provided by the control modules concerning the environment, lights and/or control modules. The long-distance communication module can be based on different techniques. For example it could be a cellular network, an ip-network or a long range peer to peer network.

**[0011]** As environmental information, in addition to geocoordinates, information regarding adjacent control modules in the short-distance network (e.g. connection quality and other RF characteristics or neighbourhood tables) and/or environment-specific information (e.g. light intensity in the surroundings) may be taken into consideration. The information concerning the lights may be information regarding the illuminants used, their drivers and/or further details of the allocated light, e.g. the current light intensity or dimming. The control module information is particularly information used for clear identification of the control module, such as its IP address or another UID (Unique Identifier). According to this invention, the server selects one control module per group, or in case of a single group of the group, as group controller. The other control modules of the corresponding group use their short-distance communication modules to communicate with this controller. This means communication within a group uses the corresponding short-distance communication modules. Within the group, the control modules of the group form a short-distance network via their corresponding short-distance communication modules, preferably a mesh network. During (normal) operation of the network, the group controller can only transmit its own environmental, light and/or control module information and the information received from its other control modules to the server via the long-distance communication module. For both, the methods described above and below, transmission of information is always executed through transmission of the corresponding data on the basis of specific communication protocols.

**[0012]** During normal operation of the network, the group controller can only transmit its own

environmental, light and/or control module information and the information received from its other control modules to the server via the long-distance communication module. For this purpose, normal operation is understood as the usual operation of the network, in which each control module of the network is allocated to a group and in which all control modules carry out their actual task, controlling the light.

**[0013]** A network set-up like this leads to a more stable operation than previous network systems. Due to the redundant set-up of the respective control modules within a group, a new group controller can easily be determined by the server in case of a group controller failure. Once the new group controller has been announced within a group, i.e. on the level of the short-distance communication network (PAN = Personal Area Network), the other control modules not defined as group controllers establish their connections via the group controller. This means that the server can continue to control and monitor the system. At the same time, the single active control module (group controller) per group makes expenses significantly lower than in a network where all control modules communicate separately with the server via their respective long-distance module.

**[0014]** The set-up of the internal group network as mesh network makes the system and communication on the PAN level more fail-safe.

**[0015]** If "with" is used above or below to explain process steps, this does not necessarily mean that the connected process steps are simultaneous. Rather, these process steps may (but do not have to) be simultaneous.

**[0016]** The expansion of the network is furthermore made easier if the network automatically records geo-information, particularly during initial commissioning/start-up, preferably when voltage is first applied, as it then carries out this process automatically after a new control module is switched on. This geo-information consists of location data, i.e. coordinates and a precise time stamp. The geo-information is registered by means of the geocoordinates module. At the same time or subsequently, the long-distance communication module logs in with a network provider. Preferably this should be a provider of communication lines, e.g. a cellular network provider. A long distance communication network usually would be at least a cellular network. This log-in can take place under roaming conditions, which means that, regardless of where the respective control modules are to be set up at a later time, the factory must always only provide identical log-in information. Therefore, the controller and/or long-distance communication module have consistent log-in data on the control module side.

**[0017]** After log-in with the network provider, the geo-information can then be transmitted to the server together with information regarding the control module and/or lights provided by the new control module. The automatic storage of the data in a corresponding database by the server facilitates uncomplicated set-up of street lights. To reduce communication costs, provider access data specific to an existing long-distance network can be transmitted after the new control module's information has been transmitted.

**[0018]** The processes described above and below also apply to the integration of several new control modules.

**[0019]** In particular, the provider access data can be provided to the new control module via firmware, if it is equipped with an electronic SIM. In this case, the new firmware is transferred to the controller or the long-distance communication module, so that commissioning/start-up of the new control module becomes possible at low cost and under local conditions. Accordingly, provision of firmware by the server can achieve flexible communication and installation of the new control modules without them having to be equipped differently by the factory.

**[0020]** To simplify the management of a multitude of networks, in particular of street lights, it is beneficial to carry out allocation to a group and further data exchange with the new control module via a dedicated project server after the initial commissioning of the new control module and its first log-in on a log-in server.

**[0021]** A server in this case is not necessarily a separate data processing system with separate hardware. It can also merely be a project-specific separation within a telemanagement program. It may also be a virtual server on the same hardware or within a cloud.

**[0022]** To facilitate problem-free operation, the project server could preferably be provided with information about the commissioned devices by the log-in server after the initial log-in.

**[0023]** To lower costs, an interface from the server to the long-distance network provider or the network provider should preferably be used to transfer information regarding the control modules active within their long distance communication, to be suspended and/or to be made inactive. This means that the provider guarantees that only a low number of control modules (one control module per group) is active. The other control modules can only communicate with the server via the communication path within the mesh network and then via the group controller. A suspension, especially of an electronic SIM, means that it can be activated for a short time in case of doubt, for instance if the group controller fails. Preferably the network compensates for the failure of one communication path and establishes a new one automatically and thus with a minimum delay. The new communication can be initiated through a corresponding request by the server or through a time-controlled inquiry and an attempt to access the provider network by the control module.

**[0024]** The server can then transmit information to the other control modules, making these control modules communicate with the new group controller during normal operation.

**[0025]** To set up a mesh network, it can be advantageous for the respective group controller to receive data about the members of its group, especially new control modules, from the server and for the group controller to determine itself as group controller in relation to the other group members. As an alternative or in addition, the other group members may receive data about the communication path or the desired group controller to ensure that communication with the

server remains problem-free.

**[0026]** Accordingly, the information provided by the server can be information for the control modules, which informs these about adjacent control modules of the same group. The server may, for instance, extract this data by observing the geocoordinates of the respective control modules.

**[0027]** After a successful initialisation or expansion of the mesh network, the group controller can transmit this message to the server. The server can then continue to guide the expanded group in normal operation.

**[0028]** To signal successful commissioning/start-up, for instance successful integration of a control module into the group network (PAN) or successfully established contact with a server, to the operating personnel when a new light or a new control module is installed and/or after maintenance work on the respective light, the control module can operate the light at different brightness levels over predetermined or determinable time intervals once the desired state has been reached.

**[0029]** Preferably the new control module receives a parameter set for operating the light from the server after initial installation and/or re-installation. This set may, for instance, consist of dimming curves.

**[0030]** Furthermore, operation of a network of lights is improved, if the control modules of a group are provided with software updates by a software transmitted from the server to the group controller and subsequently or simultaneously transmitted further. This may, for example, make new light functions possible or release them for use.

**[0031]** As an alternative, a control module may receive a new controller software, in particular firmware, directly from the server, by-passing the group controller. However, for this purpose the respective control module must first be reactivated with the provider.

**[0032]** To facilitate the fastest possible start-up of the network without delays, possible new control modules can scan the short-distance network for other control modules automatically after they are first started up, thereby creating an internal table of adjacent modules which contains the closest adjacent modules in the short-distance network. This list can later be transmitted to the server. In particular, this adjacent module information can be transmitted to the server together with other light-specific or control module-specific information after the mesh network is set up and a group controller has been allocated.

**[0033]** For fail-safe operation and problem-free expansion of the network, it is beneficial if at least a part of the control modules, preferably in one group and specifically in response to a server request, receive information about adjacent control modules via the short-distance communication module, depending on the number of new control modules, the closeness of the new control modules, the distance of new control modules from the group controller and/or

the frequency of disruptive events. These control modules shall register the quality of the connection to the adjacent control modules and transmit this information to the server via their short-distance communication module and the group controller or directly via their long-distance communication module, which will cause the server to make the group division and determine the group controller, check this division/determination and/or change it, if necessary.

**[0034]** To do so, the control modules may switch to another PAN-internal communication mode and contact adjacent control modules via the respective short-distance communication module and register these as well as the quality of their connection to them.

**[0035]** The registration of adjacent module information can be time-limited. Once a specific time has elapsed and/or after identification of a specified number of closely adjacent modules, this information can be transmitted to the group controller via the respective short-distance communication module or, if the connection is active, to the server via the long-distance communication module, possibly together with other geo- and/or light- and/or control module-specific information. The server can use this information to check the group division and group controller allocation and/or revise it, if necessary.

**[0036]** A particular advantage for network installation is achieved through a process in which, preferably for transmitting light-specific information, an information medium for registering light-specific information located on part of the light is read out by the control module automatically and/or after being triggered. This information medium may be a chip, a memory card, an RFID tag or similar information carriers which can be read out without being touched. Preferably the information medium will be read out by a near field sensor of the control module without being touched. For instance, this may be an RFID reader, which communicated with an RFID transponder or tag. The read-out information can be used by the control module to select specific operating parameters, or it can merely be transferred to the server, for instance so that operating parameters can be transferred from there.

**[0037]** Maintenance of a light network according to this invention is also improved, if the light-specific information of the new control module is linked with a inventory list on the server, preferably with the contents of this list, at least partially being displayed if a component of the light fails. The individual components of the light may be equipped with a link to a web shop or a different ordering method so that potentially inoperative parts can be ordered without a delay.

**[0038]** Instead of observing information about their short-distance network environment on the basis of malfunctions or a request based on the number of new control modules of a group, the modules can preferably register this information at a pre-determined time and/or due to an initialisation by the server. For this purpose it may be helpful to limit communication within the mesh network via the group controller to the server for a short time and only allow observation and communication with the closest adjacent modules in the mesh network based on the short-distance module and the respective protocol. This serves to create neighbourhood module tables or lists, with information about the signal strength and/or quality of the connection to the respective adjacent modules being registered at the same time. This information can be

cached and/or stored and then transmitted via the group controller or, if all long-distance communication modules of the control modules are active, transmitted directly to the server.

**[0039]** For targeted inspection or checking the status of several control modules, these should preferably be pre-selected by the server before a predefined inquiry, a process in which for instance the control module concentration can be determined and checked on the basis of a pre-defined or definable limit value. Subsequently, if the limit value is exceeded, a redetermination of the environment, light and/or control module specific information can be initialised.

**[0040]** To enable the server to select a suitable group controller and integrate new control modules optimally, it may be beneficial to have the respective control modules register and save data concerning their UID in the short-distance network, their IP address in the long-distance network, their UID in the near field network, light-specific information, data of a number of neighbours in the short-distance network, particularly of up to 50, preferably of up to 10 adjacent control modules in the short-distance network including their UIDs and/or the connection quality of the adjacent control modules during a scan process and then have this information (data) transmitted via the group controller to the server at a given time. If the control module is active, i.e. equipped with an active long-distance network access, the server may receive this information directly from the control module.

**[0041]** The commissioning of the network and the division into groups and/or allocation of the group controller on the server should preferably be carried out automatically. As an alternative or in addition, the division into groups and/or allocation of the group controller may be varied by user input. For instance, this is beneficial if a program running on the server causes an ambiguous selection of a group controller.

**[0042]** To keep the latency in the network under a desired level, a maximum definable number of control modules should preferably be allocated to each group being set on the server, with 200 control modules potentially being the upper limit. Tests and simulations with up to 2000 lights have shown that the latency in larger network groups becomes too large to guarantee proper operation and regular inspection of the network status.

**[0043]** Preferably the number of control modules should be less than 200 per group, particularly less than 50 control modules.

**[0044]** Furthermore the stability of the system is improved sufficiently if the selection of a controller as group controller based particularly on fuzzy control strategies is automatic. Accordingly the suspension or deactivation of a control module based on fuzzy control strategies can also be automatic.

**[0045]** In particular, the selection of the group controller and/or allocation of the control modules to their respective group can take into account at least some of the rules for:

- the ratio of active to inactive control modules,
- the availability of adjacent control modules in the short-distance network,
- the number of network malfunctions,
- the network changes (new control modules in relation to deleted control modules),
- the changes of connection quality in the short-distance network,
- the estimated cost of connection to the long-distance network provider,
- the communication of sensor data between adjacent groups,
- the latency within a group (including distance-dependent delay),
- fall-back options (replacement of failed group controllers) and/or
- a stabilisation component to take into account a time-controlled

damping

**[0046]** Preferably the rules are mapped and linked by an AI system. A simple combination of these rules can be based on logic operations, e.g. AND/OR/NOR combinations.

**[0047]** Furthermore, the fail safety is increased if at least one replacement group controller is defined by the server according to the control strategies, which switches from a suspended to an active state if the actual group controller fails.

**[0048]** To make detection of environment information by the short-distance network and communication in the short-distance network for purposes of the normal operation (communication with the server) more problem-free, it may be beneficial for the corresponding communication in the short-distance network to take place on different frequency bands of said network. Preferably the same antennae can be used for this (multiplex operation).

**[0049]** According to a further development of the method according to this invention, information relevant for multiple groups can be exchanged between adjacent groups. To ensure that particularly sensor information relevant for multiple groups or data relevant for multiple groups based on sensor information can be transmitted fast, for instance information regarding the lighting situation for a driving car or a pedestrian, it is beneficial if the respective information can be transmitted directly via the long-distance network to a control module of an adjacent group, by-passing the server. In particular, this information can be transmitted directly from the control module equipped with the sensor which created the information. Accordingly, the communication can be carried out via the long-distance network provider, but does not have to use the server. For protocol purposes the server can be informed of the respective information. In particular, transmission of this information uses the known group controllers in the long-distance network.

**[0050]** As an alternative, data relevant for multiple groups based on sensor information can be transmitted directly via the short-distance network to a control module of an adjacent group, by-passing the server, with transmission of the data preferably using a different frequency band than the one used during normal operation within one group. For this purpose, multiplex operation of the short-distance module can, once again, be an advantage.

**[0051]** It is beneficial for the server, if in the corresponding software a group-independent selection of control modules for the exchange of data relevant for multiple groups can be made. This can be supported graphically, for instance if those control modules which are to exchange sensor information are marked on an overview map. This makes it possible for large crossroads on the border of adjacent groups equipped with control modules belonging to different groups to be marked, to quickly increase the lighting volume in the driving direction of an approaching car.

**[0052]** A network according to this invention designed as described above and below also has the corresponding advantages.

**[0053]** For further advantages and detailed features of the invention, refer to the following figure descriptions. The schematic figures show:

Fig. 1 a network according to this invention,

Fig. 2 a further object according to this invention,

Fig. 3 a simplified flow diagram for a process according to this invention,

Fig. 4 a further object according to this invention,

Fig. 5 a component of an object according to this invention.

**[0054]** Individual technical features of the design examples described below can also be combined with design examples described above as well as the features of independent claims and potential further claims to form objects according to this invention. If it makes sense, functionally equivalent elements are given the same reference number.

**[0055]** The method for operation and expansion of a network of lights according to this invention results in the system depicted in a simplified manner in fig. 1 with a multitude of control modules 1, each of which are allocated to a control module designated as group controller 2. The hardware of group controller 2 is identical to control modules 1. However, only the respective group controller 2 can use long-distance connection 3 to communicate with a server 4. The other control modules 1 of a group are suspended and/or inactive for long-distance communication. Typically this is access to a local cellular network provider, through which the server can then remain accessible based on IP-WAN.. Communication between the servers and group controllers can, for instance, be carried out via a common internet protocol (TCP/IP).

**[0056]** Within a group 7, the control modules communicate with each other via short-distance connections 6. Preferably this communication should be based on a mesh network on the IEEE 802.15.4 standard, for example ZigBee.

**[0057]** The individual groups 7 of control modules 1, 2 can generally not see each other and therefore cannot interfere with each other. However, for communication of several groups it may be intended for control modules with adjacent locations to use short-distance connection 8 to share/exchange or forward sensor data or corresponding information between groups. This can then be used to initiate actions such as an increase of the light volume. As an alternative, this communication may also use the corresponding group controllers 2, which can see each other through their IP addresses in the inter- or intranet. The information regarding which control module may communicate with which other control module and how this module can communicate is defined on the server and carried out, for instance in case of short-distance communication between groups, in particular by means of a multiplex unit of each control module.

**[0058]** Furthermore, a server for operating a network according to this invention can control a state-of-the-art network with a segment controller 8 (fig. 2) in addition to connecting to one or several groups 7 of control modules 1, 2, which form a PAN. This segment controller manages several light controllers 9. The segment controller 8 is connected via an interface 11, which makes data exchange with server 4 possible. In addition to a connection to several groups 7 via, if necessary, an additional interface 12, the server 4 can exchange data with a long-distance network provider 14 via another interface (API) 13.

**[0059]** In general, a database 16 runs on the server, interacting with different operating modules (clients) 17. A graphical user interface 18 grants the user access to the server and its programs for operation and control purposes.

**[0060]** Fig. 3 briefly describes the process of setting up a network of street lights. After installation 19 of a number of new control modules on street lights, these will scan their environment in phase 20 which is either started by the server or starts automatically. They then transmit environment information and possible light-specific or control module specific information to the server. This can take place either directly under roaming conditions with a first provider or, if necessary, with a local network provider determined by the server after the first log-in of the respective control modules. Once the environmental and other information has been transmitted by the respective control modules of the street light, an analysis of the control modules and allocation 21 into groups takes place. On the PAN level, integration of one or more new control modules can be dynamic on the basis of the standard in use. Once the respective group controller has transmitted a data signal to the server, informing the server that the internal group communication with the new control module has been successfully established, the system switches over to expanded normal or usual operation 22.

**[0061]** If additional control modules in a quantity pre-determined on the server have been installed, the process can be carried out again according to feedback loop, in which case a new division into groups or new allocation of a group controller can take place based on the transmitted information and the rules available to the server.

**[0062]** According to another design example of the invention according to fig. 4, a number of

lights with their respective control modules 23 and 23' are arranged along a street 24. These lights belong to a group of lights or control modules A, which was pre-determined on the server. Both group A and group B are marked by the broken lines 26 or 27. Group B contains lights with their corresponding control modules 28 or 28' which are placed alongside an intersecting street 29 leading into street 24. The inner black circles 31 and 32 mark a light with an active control module, a group controller. Sensors S1 and S2 are allocated to control module 23 and 28 respectively. As sensors, above all, radar sensors, infra red sensors (particularly passive infra red sensors) or induction loops in street 24 or 29 may be considered. These detect an approaching object, leading to the control modules both within a group and between groups adapting the light of the respective street light of the group to the situation.

**[0063]** For instance, sensor S1 of the control module 23 of street light detects an approaching object, e.g. a car, the information is shared in group A, the light intensity of group A is increased by control modules 23 and 23' and this information or the information about the approaching car is transmitted via group controller 23' to the group controller 28' of group B. Subsequently, the brightness of the relevant lights of control modules 28 or 28', i.e. those selected by the server, is adjusted as well. As an alternative, the control module 23 equipped with sensor S1 could communicate directly with the group controller 28' of group B or another control module 28 of a street light allocated to this group controller, which means that this information is shared in the network and group B reacts accordingly.

**[0064]** Allocation of the respective control modules and therefore the corresponding street lights of a first group, which are to be provided with sensor information of an adjacent group's sensor and through which the information is then transmitted between groups, can be carried out on the server. Input masks are available for this purpose, particularly on the server.

**[0065]** A control module according to this invention, which can be used to implement the method described above, is preferably designed as a separate unit, which can be installed on a light head, for instance of a street light (cf. fig. 7). For further details regarding the crucial components of an externally installed control module, see fig. 5. The exploded view of this figure comprises the control module, a top housing part 33 and a bottom housing part 34. The bottom housing part is to be fastened to a base fitted on top of the light by means of seal 35. The part is connected with the base through bayonet-type twisting contacts 37. These contacts 37 are fastened in housing 34 and also the location of the central circuit board unit 38. Among other things, a controller 39, short- and long-distance communication modules and an acceleration sensor unit 41 for detecting in particular seismic waves are located on this circuit board unit.

**[0066]** This figure does not show an RFID reader, which can be installed in a base on the light housing side in order to register light-specific data of an RFID transponder in the near field.

## **REFERENCES CITED IN THE DESCRIPTION**

This list of references cited by the applicant is for the reader's convenience only. It does not form part of the European patent document. Even though great care has been taken in compiling the references, errors or omissions cannot be excluded and the EPO disclaims all liability in this regard.

**Patent documents cited in the description**

- US2012147604A1 [0005]
- WO2015000803A1 [0006]

**Patentkrav**

1. Fremgangsmåde til drift og udvidelse af et netværk af lygter inklusive trinnene:

- at tilvejebringe et netværk af lygter omfattende en flerhed af gadelygter og en flerhed af styringsmoduler (1,2,23,23',28,28'), idet hver gadelygte har et styringsmodul allokeret derfor og er indrettet til at styre driften deraf, idet hvert styringsmodul omfatter:
    - et langdistancekommunikationsmodul,
    - et kortdistancekommunikationsmodul,
    - et geokoordinatmodul,
    - en styringsanordning og
    - en styringsudgang indrettet til at styre en driver af gadelygten allokeret til nævnte styringsmodul;
  - at tilvejebringe mindst en server (4) opnåelig via langdistancekommunikationsmodulet af hvert styringsmodul;
- 15 **kendetegnet ved at** den mindst ene server (4) indeler styringsmodulerne (1,2,23,23',28,28') i flere styringsmodulgrupper (A,B) baseret på mindst en af miljø-, lygte- og styringsmodulinformation tilvejebragt af styringsmodulerne (1,2,23,23',28,28');
- ved at** den mindst ene server (4) vælger et af styringsmodulerne (1,2,23,23',28,28') af hver gruppe (A,B) som en gruppestyringsanordning (2,23',28'), med hvilken alle andre styringsmoduler (1,23,28) af den respektive gruppe (A,B) kan kommunikere via deres kortdistancekommunikationsmoduler, hvor hvert styringsmodul af netværket er allokeret til en gruppe i normal drift; og **ved at** fremgangsmåden inkluderer trinnene:
- at danne et kortdistancenetværk med styringsmodulerne (1,2,23,23',28,28') inden for hver gruppe via deres tilsvarende kortdistancekommunikationsmoduler;
  - at transmittere, fra hvert styringsmodul (1, 23, 28), andet end gruppestyringsanordningen (2), via dets respektive kortdistancekommunikationsmodul, mindst en af dets miljø-, lygte- og styringsmodulinformation til gruppestyringsanordningen (2, 23', 28') af den respektive gruppe;
  - at transmittere under normal netværksdrift fra hver gruppestyringsanordning (2,23',28',) af en respektiv gruppe, mindst en af dens egen miljø-, lygte- og styringsmodulinformation og den tilsvarende

information modtaget fra de andre styringsmoduler (1, 23, 28) af den respektive gruppe til den mindst ene server (4); idet fremgangsmåden omfatter de følgende yderligere trin:

- 5 - ved første ibrugtagning og opstart af et nyt styringsmodul registrerer nævnte nye styringsmodul dets geografiske koordinater og et tidsstempel derfor ved hjælp af dets geokoordinatmodul;
- nævnte nye styringsmodul logger ind med en netværksudbyder (14) via dets langdistancekommunikationsmodul; og
- 10 - nævnte nye styringsmodul transmitterer til den mindst ene server (4) nævnte geografiske koordinater og tidsstempel sammen med mindst en af dets lygte- og styringsmodulinformation.

**2.** Fremgangsmåde ifølge krav 1, hvor nævnte nye styringsmodul ibrugtages første gang og opstartes, når spænding først påføres.

**3.** Fremgangsmåde ifølge krav 1 eller 2, hvor trinnet at logge ind for nævnte nye styringsmodul med en netværksudbyder (14) udføres under roaming-betingelser.

20 **4.** Fremgangsmåde ifølge et hvilket som helst af de foregående krav, hvor netværksudbyderen (14) er en cellulær netværksudbyder.

**5.** Fremgangsmåde ifølge et hvilket som helst af de foregående krav, hvor hvert styringsmodul inkluderer et nærfeltkommunikationsmodul.

25

**6.** Fremgangsmåde ifølge et hvilket som helst af de foregående krav, yderligere inkluderende trinnet at transmittere specifik netværksudbyder-logindata til et lokalt tilgængeligt langdistancenetværk til nævnte nye styringsmodul efter transmissionen, fra nævnte nye styringsmodul til den mindst ene server (4), af de geografiske koordinater og tidsstempel sammen med mindst et af dets styringsmodulinformationer og lygtespecifikke informationer.

30

**7.** Fremgangsmåde ifølge krav 6, hvor netværksudbyder-logindataet gøres tilgængeligt via en firmware til et elektronisk SIM af nævnte nye styringsmodul.

35

**8.** Fremgangsmåde ifølge et hvilket som helst af de foregående krav, yderligere inkluderende trinnet at transmittere information vedrørende nævnte nye styringsmodul til netværksudbyderen (14) via en grænseflade til nævnte netværksudbyder.

5

**9.** Fremgangsmåde ifølge et hvilket som helst af de foregående krav, yderligere inkluderende trinnet at forsyne styringsmodulerne af en gruppe med softwareopdateringer af en software overført fra den mindst ene server (4) til gruppestyringsanordningen af nævnte gruppe.

10

**10.** Fremgangsmåde ifølge et hvilket som helst af de foregående krav, hvor nævnte nye styringsmodul modtager en styringsanordningsfirmware fra den mindst ene server (4).

15 **11.** Fremgangsmåde ifølge et hvilket som helst af de foregående krav, hvor nævnte nye styringsmodul modtager fra nævnte mindst ene server (4), et parametersæt til at drive sin lygte.

**12.** Fremgangsmåde ifølge et hvilket som helst af de foregående krav, hvor hvert  
20 styringsmodul er indrettet til at drive sin lygte ved forskellige lysstyrkeniveauer over et forudbestemt eller bestemt tidsinterval, efter spænding påføres.

**13.** Fremgangsmåde ifølge et hvilket som helst af de foregående krav, yderligere inkluderende trinnene:

25       - at allokere nævnte nye styringsmodul til en gruppe (A, B); og  
      - at informere gruppestyringsanordningen (2, 23', 28') af nævnte gruppe om nævnte nye styringsmodul.

30 **14.** Fremgangsmåde ifølge et hvilket som helst af de foregående krav, hvor mindst nogle af styringsmodulerne:

      - modtager information om tilstødende styringsmoduler (1,2,23,23',28,28') via deres respektive kortdistancekommunikationsmodul, nævnte information vedrørende antallet af nye styringsmoduler, tætheden af de

- nye styringsmoduler, afstanden af nye styringsmoduler fra den respektive gruppestyringsanordning og/eller frekvensen af forstyrrende begivenheder;
- registrerer kvaliteten af forbindelsen til de tilstødende styringsmoduler;
- og
- 5 - transmitterer information om nævnte registrerede kvalitet af forbindelsen til den mindst ene server (4) via deres respektive kortdistancekommunikationsmodul og gruppestyringsanordningen af deres respektive gruppe eller direkte via deres respektive langdistancekommunikationsmodul;
- 10 hvor den mindst ene server (4), baseret på den modtagne information, udfører mindst et af de følgende trin:
- at foretage inddelingen i grupper og valget af gruppestyringsanordningerne;
  - at kontrollere inddelingen i grupper og valget af
- 15 gruppestyringsanordningerne; og
- at ændre inddelingen i grupper og valget af gruppestyringsanordningerne.
- 20 **15.** Fremgangsmåde ifølge krav 14, hvor registreringen af kvaliteten af forbindelsen til de tilstødende styringsmoduler er tidsbegrænset.
- 16.** Fremgangsmåde ifølge et hvilket som helst af de foregående krav, hvor mindst en af inddelingen i grupper (A,B) og valget af
- 25 gruppestyringsanordningerne (2,23'28') på den mindst ene server (4) udføres automatisk.
- 17.** Fremgangsmåde ifølge et hvilket som helst af kravene 1 til 15, hvor mindst en af inddelingen i grupper (A,B) og valget af gruppestyringsanordningen (2,23'28')
- 30 er variabel gennem brugerinput.
- 18.** Fremgangsmåde ifølge et hvilket som helst af de foregående krav, hvor antallet af styringsmoduler i hver gruppe (A, B) er lig med eller lavere end et specifikt antal.

- 19.** Fremgangsmåde ifølge krav 18, hvor det specifikke antal er 200.
- 20.** Fremgangsmåde ifølge et hvilket som helst af kravene 1 til 15 eller 17 til 19, hvor valget af et styringsmodul som en gruppestyringsanordning (2, 23', 28') er automatisk og baseret på fuzzy-styringsstrategier.
- 21.** Fremgangsmåde ifølge et hvilket som helst af de foregående krav, hvor den mindst ene server (4) standser eller deaktiverer langdistancekommunikationsmodulet af et styringsmodul, hvor standsningen eller deaktiveringen er automatisk og baseret på fuzzy-styringsstrategier.
- 22.** Fremgangsmåde ifølge kravene 20 eller 21, hvor fuzzy-styringsstrategierne tager højde for regler for mindst et af:
- a) forholdet mellem aktive og inaktive styringsmoduler,
  - b) tilgængeligheden af tilstødende styringsmoduler i kortdistancenetværket,
  - c) antallet af netværksfunktionsfejl,
  - d) netværkændringerne,
  - e) ændringerne af forbindelseskvalitet i kortdistancenetværket,
  - f) den anslåede omkostning af forbindelse til netværksudbyderen,
  - g) latenten, og
  - h) funktionsfejl og erstatning af aktive gruppestyringsanordninger.
- 23.** Fremgangsmåde ifølge et hvilket som helst af de foregående krav, yderligere inkluderende trinnene:
- at definere mindst en erstatningsgruppestyringsanordning ved den mindst ene server (4) ifølge styringsanordningsstrategier; og
  - at omskifte mindst en erstatningsgruppestyringsanordning fra en standset til en aktiv tilstand, hvis den aktuelle gruppestyringsanordning (2, 23', 28') svigter.
- 24.** Fremgangsmåde ifølge et hvilket som helst af de foregående krav, hvor nævnte nye styringsmodul, efter først at blive tændt, scannet

kortdistancenetværket for andre styringsmoduler.

**25.** Fremgangsmåde ifølge et hvilket som helst af de foregående krav, hvor nævnte nye styringsmodul, automatisk og/eller efter at være blevet udløst, 5 udlæser et informationsmedium placeret på en del af gadelygten allokeret til nævnte nye styringsmodul, idet informationsmediet er til at registrere lygteinformation af nævnte nye styringsmodul.

**26.** Fremgangsmåde ifølge kravene 5 og 25, hvor informationsmediet udlæses via 10 nærfeltkommunikationsmodulet af nævnte nye styringsmodul.

**27.** Fremgangsmåde ifølge et hvilket som helst af de foregående krav, yderligere inkluderende trinnene:

- 15 - at forbinde lygteinformationen af lygten allokeret til nævnte nye styringsmodul til en lagerliste; og
- mindst delvist at vise indholdet af lagerlisten.

**28.** Fremgangsmåde ifølge et hvilket som helst af de foregående krav, hvor 20 styringsmodulerne transmitterer til den mindst ene server (4) data vedrørende mindst en af: deres unikke identifikation, UID, i kortdistancenetværket; deres IP-adresse i langdistancenetværket, deres UID i kortdistancenetværket; lygteinformation; og data relateret til op til 50 tilstødende styringsmoduler i kortdistancenetværket inklusive mindst en af deres UID'er og 25 forbindelseskvaliteten af de tilstødende styringsmoduler.

**29.** Netværk af lygter omfattende en flerhed af gadelygter, idet hver gadelygte har et styringsmodul allokeret derfor indrettet til at styre driften deraf, idet hvert styringsmodul omfatter:

- 30 - et langdistancekommunikationsmodul,
- et kortdistancekommunikationsmodul,
- et geokoordinatmodul,
- en styringsanordning, og
- en styringsudgang indrettet til at styre driveren af gadelygten allokeret til 35 nævnte styringsmodul,

hvor netværket af lygter yderligere omfatter mindst en server (4) opnåelig via langdistancekommunikationsmodul af hvert styringsmodul,

**kendetegnet ved at** styringsmodulerne (1,2,23,23',28,28') er inddelt i flere styringsmodulgrupper (A,B) baseret på mindst en af miljø-, lygte-, og

5 styringsmodulinformationer tilvejebragt af styringsmodulerne,

hvor et af styringsmodulerne af hver gruppe (A,B) vælges som en

gruppestyringsanordning (2, 23', 28') med hvilken alle andre styringsmoduler

(1,23,28) af den respektive gruppe (A,B) kan kommunikere via deres

kortdistancekommunikationsmoduler,

10 - hvor styringsmodulerne (1, 2, 23, 23', 28, 28') inden for hver gruppe danner et kortdistancenetværk via deres tilsvarende kortdistancekommunikationsmoduler;

- hvor hvert styringsmodul (1,23,28) andet end gruppestyringsanordningen er indrettet til at transmittere via dets respektive

15 kortdistancekommunikationsmodul, mindst en af dens miljø-, lygte- og styringsmodulinformationer til gruppestyringsanordningen (2,23',28') af den respektive gruppe;

- hvor gruppestyringsanordningen (2,23',28') er indrettet til at transmittere, under normal netværksdrift, mindst en af dens egen miljø-,

20 lygte- og styringsmodulinformation og den tilsvarende information modtaget fra de andre styringsmoduler (1, 23, 28) af den respektive gruppe til den mindst ene server (4), og

hvor netværket omfatter mindst et nyt styringsmodul, og hvor det mindst ene nye styringsmodul er indrettet til at:

25 - registrere dets geografiske koordinater og et tidsstempel derfor ved hjælp af dets geokoordinatmodul, når nævnte nye styringsmodul først ibrugtages og opstartes,

- være logget med en netværksudbyder via dets langdistancekommunikationsmodul, og

30 - transmittere til den mindst ene server (4) nævnte geografiske koordinater og tidsstempel sammen med mindst en af dets lygteinformation og styringsmodulinformation.

# DRAWINGS

Fig. 1

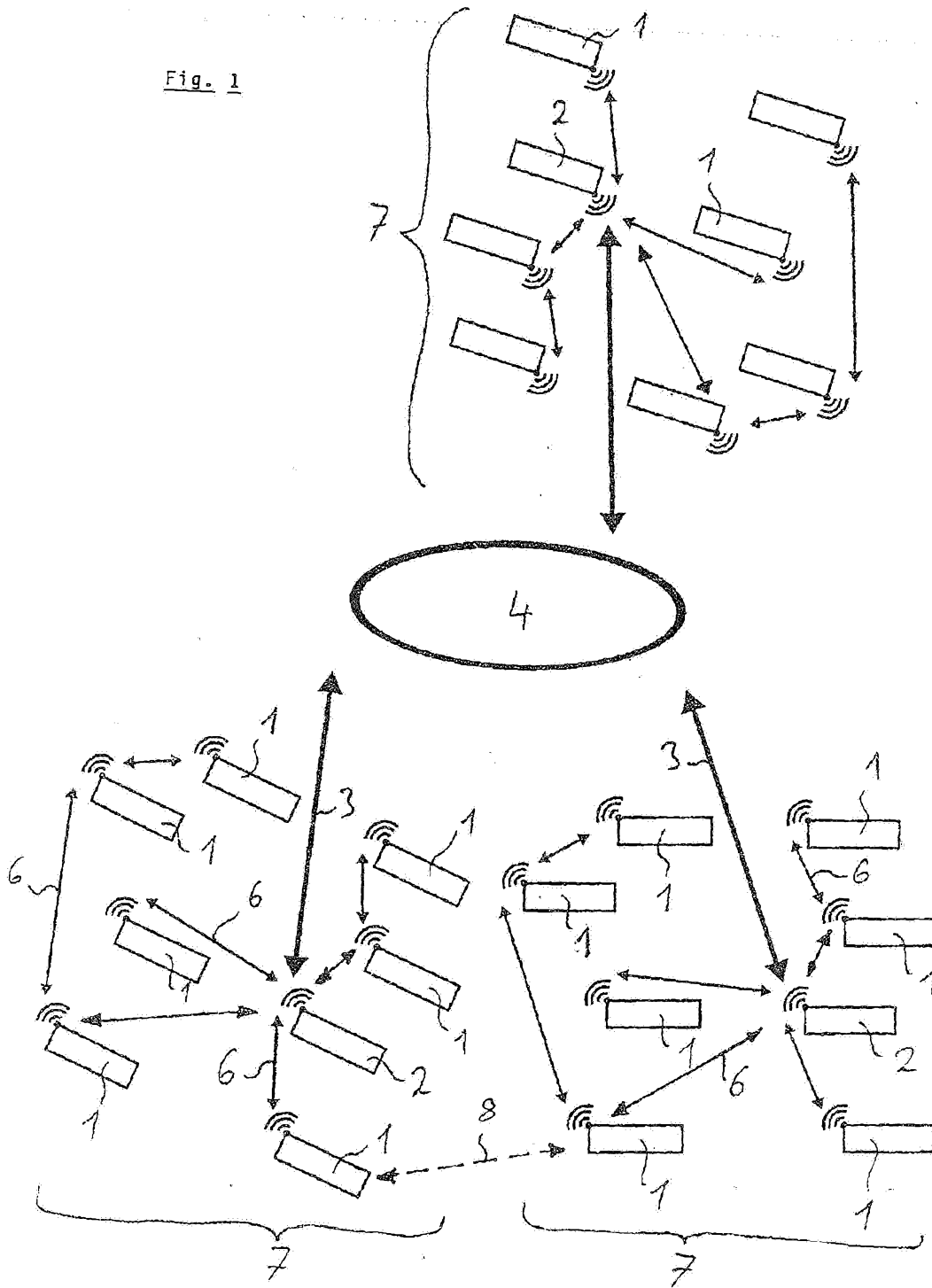
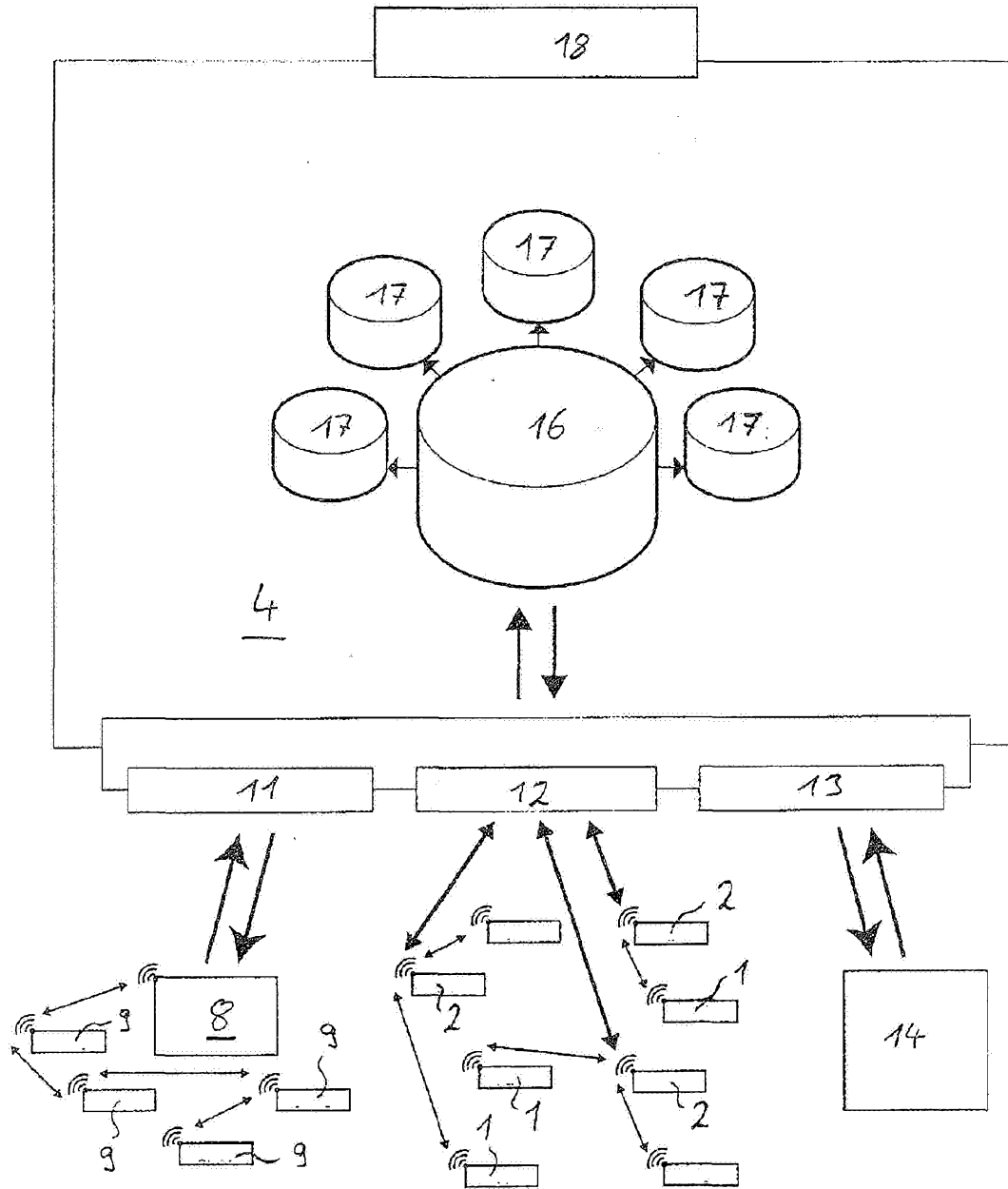

Fig. 2



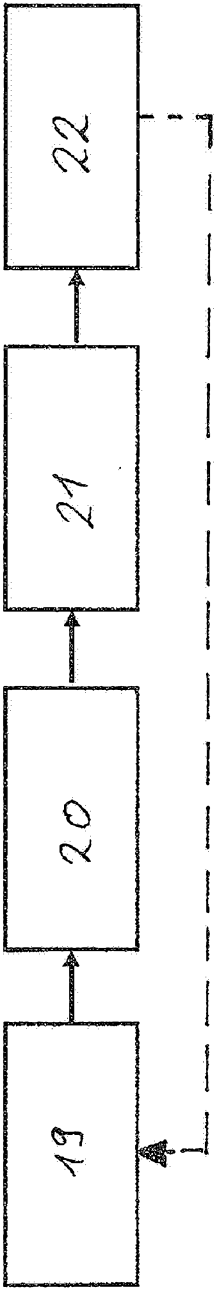

Fig. 3

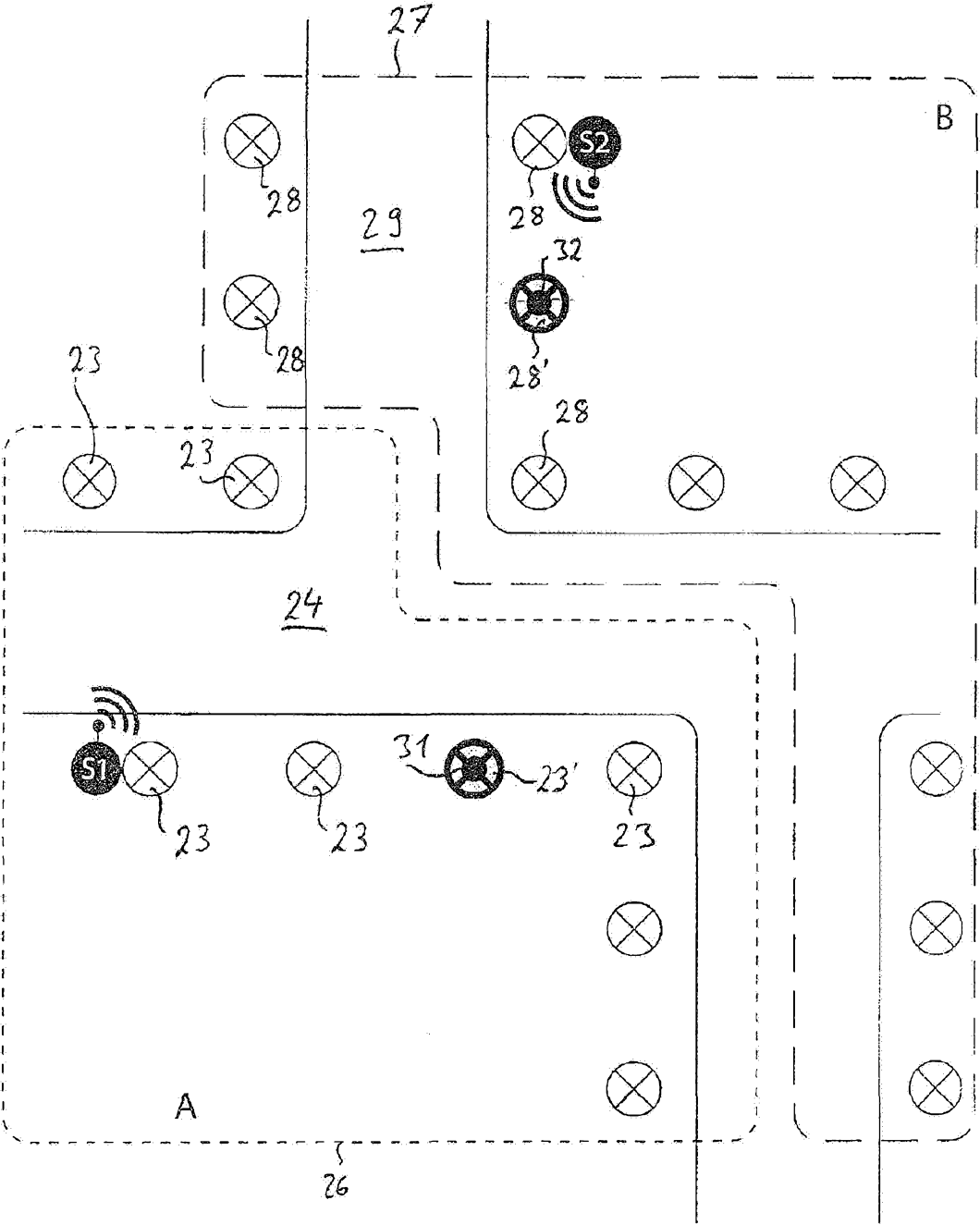

Fig. 4

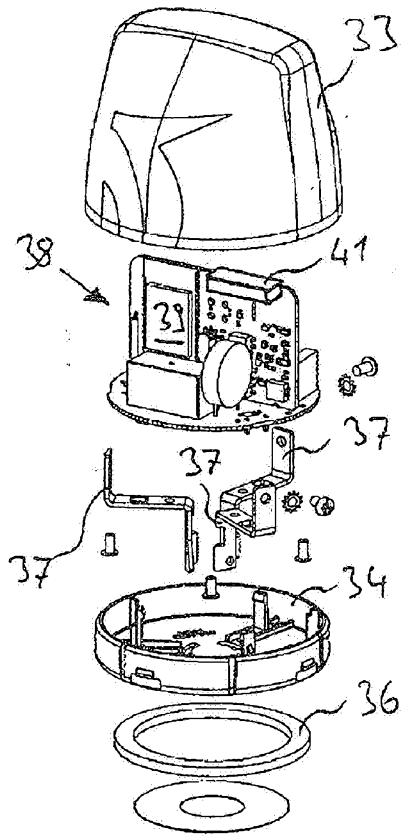

Fig. 5