

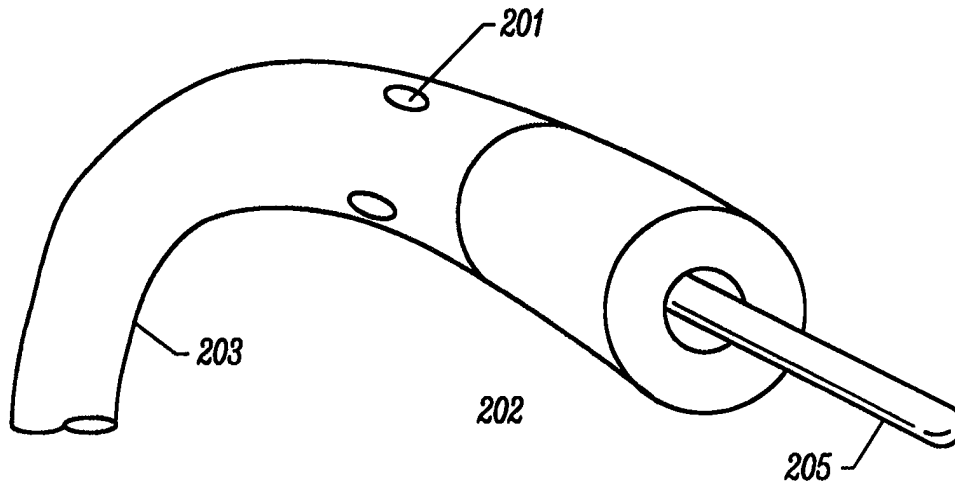

INTERNATIONAL APPLICATION PUBLISHED UNDER THE PATENT COOPERATION TREATY (PCT)

<p>(51) International Patent Classification ⁶ : A61B 17/22</p>	<p>A1</p>	<p>(11) International Publication Number: WO 98/18391 (43) International Publication Date: 7 May 1998 (07.05.98)</p>
<p>(21) International Application Number: PCT/US97/19993 (22) International Filing Date: 29 October 1997 (29.10.97) (30) Priority Data: 60/029,401 30 October 1996 (30.10.96) US (71) Applicant (for all designated States except US): EKOS CORPORATION [US/US]; Suite 148, 22122 20th Avenue, S.E., Bothell, WA 98021 (US). (72) Inventors; and (75) Inventors/Applicants (for US only): TACHIBANA, Katsuro [JP/JP]; 6-18, Kusagae 1-chome, Chuo-ku, Fukuoka-shi, Fukuoka 810 (JP). HANSMANN, Douglas, R. [US/US]; 5008 Rockaway Beach Road, N.E., Barnbridge Island, WA 98110 (US). (74) Agent: DAVIS, Paul; Wilson Sonsini Goodrich & Rosati, 650 Page Mill Road, Palo Alto, CA 94034-1050 (US).</p>		<p>(81) Designated States: JP, US, European patent (AT, BE, CH, DE, DK, ES, FI, FR, GB, GR, IE, IT, LU, MC, NL, PT, SE). Published <i>With international search report.</i> <i>Before the expiration of the time limit for amending the claims and to be republished in the event of the receipt of amendments.</i></p>

(54) Title: INTRALUMINAL WALL DRUG DELIVERY DEVICE



(57) Abstract

The invention relates to an apparatus for delivering a medicament into an injection site in or beyond a vessel wall or vessel obstruction including an intraluminal catheter containing: at least one puncturing element; an ultrasound emitter located in the proximity of the extendable puncturing element(s); and an introducer element that introduces the medicament into an injection site that is in or beyond the vessel wall, but within a portion of the vessel wall that has been penetrated by the puncturing element. The invention also relates to methods for treating a stenosis or obstruction in a vessel, and methods for creating a stenosis or obstruction in a vessel.

FOR THE PURPOSES OF INFORMATION ONLY

Codes used to identify States party to the PCT on the front pages of pamphlets publishing international applications under the PCT.

AL	Albania	ES	Spain	LS	Lesotho	SI	Slovenia
AM	Armenia	FI	Finland	LT	Lithuania	SK	Slovakia
AT	Austria	FR	France	LU	Luxembourg	SN	Senegal
AU	Australia	GA	Gabon	LV	Latvia	SZ	Swaziland
AZ	Azerbaijan	GB	United Kingdom	MC	Monaco	TD	Chad
BA	Bosnia and Herzegovina	GE	Georgia	MD	Republic of Moldova	TG	Togo
BB	Barbados	GH	Ghana	MG	Madagascar	TJ	Tajikistan
BE	Belgium	GN	Guinea	MK	The former Yugoslav Republic of Macedonia	TM	Turkmenistan
BF	Burkina Faso	GR	Greece	ML	Mali	TR	Turkey
BG	Bulgaria	HU	Hungary	MN	Mongolia	TT	Trinidad and Tobago
BJ	Benin	IE	Ireland	MR	Mauritania	UA	Ukraine
BR	Brazil	IL	Israel	MW	Malawi	UG	Uganda
BY	Belarus	IS	Iceland	MX	Mexico	US	United States of America
CA	Canada	IT	Italy	NE	Niger	UZ	Uzbekistan
CF	Central African Republic	JP	Japan	NL	Netherlands	VN	Viet Nam
CG	Congo	KE	Kenya	NO	Norway	YU	Yugoslavia
CH	Switzerland	KG	Kyrgyzstan	NZ	New Zealand	ZW	Zimbabwe
CI	Côte d'Ivoire	KP	Democratic People's Republic of Korea	PL	Poland		
CM	Cameroon	KR	Republic of Korea	PT	Portugal		
CN	China	KZ	Kazakstan	RO	Romania		
CU	Cuba	LC	Saint Lucia	RU	Russian Federation		
CZ	Czech Republic	LI	Liechtenstein	SD	Sudan		
DE	Germany	LK	Sri Lanka	SE	Sweden		
DK	Denmark	LR	Liberia	SG	Singapore		
EE	Estonia						

INTRALUMINAL WALL DRUG DELIVERY DEVICE

BACKGROUND OF THE INVENTION

Field of the Invention

5 This invention relates to improved catheters for introduction of medication into a body vessel.

Background of the Invention

10 Various diseases of the vascular system are localized to short lengths of arterial tissue in the wall of body vessels. The etiology of the diseases may be due to an underlying disease process such as atherosclerosis, or may be a reaction due to injury associated with balloon angioplasty or rotational atherectomy, for example. In cases of vessel wall injury, various responses including hyperplasia and vessel remodeling can cause vessel narrowing (e.g., restenosis) with
15 subsequent risk of total occlusion and hypoxia of distal tissue.

Despite extensive basic science research and clinical investigations, the solution to the problem of restenosis remains elusive. Experimental efforts have used anti-proliferative or cytotoxic drugs, antisense oligonucleotides or gene manipulation to prevent restenosis.
20 The challenge to administering such treatments is finding a satisfactory method of delivering the drug to the affected segment of vessel wall. Systemic delivery via the blood passing through the vessel lumen is, of course, the most obvious route. However, many, if not most, of the proposed drugs have systemic side effects that do not permit high

-2-

doses. Given the small acceptable dosage levels, the amount of drug available in the bloodstream is low, resulting in a small concentration gradient into the vessel wall.

Consequently, early efforts focused on finding an appropriate delivery device for such potentially toxic agents. One proposed solution was to insert a fluid delivery catheter into the lumen of a distal or proximal branch of the affected vessel and then to advance the drug delivery port to the vicinity of the lesion. This permitted delivery of the drug at a high local concentration. A disadvantage of this technique is that drugs will only momentarily be available at the lesion site because blood flow rapidly sweeps the drug downstream.

Another treatment used balloons either distal or proximal to the lesion to temporarily stop vessel flow during the treatment period. Appropriate drugs were then introduced into the vessel in the area of the lesion. The resulting longer residence time of the drug in the vessel was intended to increase efficacy of the treatment. The disadvantage of this approach, however, is that many patients are not able to tolerate such stoppage of blood flow for more than a few minutes. Furthermore, while the main lumen may be blocked by the balloon, side branches to the artery may still rapidly dissipate the drug.

Other early efforts in treating or preventing restenosis focused on use of hydrogel coated balloons, porous balloons, coated stents, or balloons with multiple chambers. Such treatments were accomplished by inflating a balloon in the immediate vicinity of the lesion and allowing drugs to transfer to the vessel wall either through the macro holes in the balloons (spray catheter) or microporous holes in the balloon (microporous balloons). See Steg P, et al: **Local delivery for percutaneous arterial gene transfer. A comparison of double and hydrogel coated balloons**, [abstract], *Circulation* 1993, **88**:660; Nabel EG, Plautz G, Boyce FM, Stanley JC, Nabel GJ: **Recombinant gene**

expression *in vivo* within endothelial cells of the arterial wall.

Science 1989, **244**:1342-1344; Gonschior P, Deil S, Maier G., Dellian M,

Goetz A, Hofling B: **Feasibility of local drug application with a new**

catheter. *J Am Coll Cardiol*, 1994, **23**:188A; Mitchel J, Azrin M, Pearsall

5 L, Curley T, Alberghini T, Bauer H, *et al.*: **Effect of local delivery of**

urokinase on platelet deposition during in-vivo balloon angioplasty

using hydrogel-coated balloons [abstract]. *J Am Coll Cardiol* 1994,

23:701; Wolinsky H, Thung SN: **Use of a perforated balloon catheter**

to deliver concentrated heparin into the wall of the normal canine

10 **artery,** *J Am Coll Cardiol* 1990, **15**:475-481; Lambert T, Dev V, Litvack

F, Forrester J, Eigler N: **Localized arterial drug delivery from a**

coated removable metallic stent: kinetics and bioactivity of

forskolin [abstract]. *Circulation* 1993, **88**:31; Lambert CR, Leone JE,

Rowland SM: **Local drug delivery catheters functional comparison**

15 **of porous and microporous designs.** *Coron Artery Dis* 1993, 4:469-

475; Wilensky R: **The problems and the promise of local drug**

delivery. *Restenosis Summit VI*, Cleveland, Ohio, 1994:352-356, all of

which are incorporated by reference. Such approaches may solve the

side branch problem, but still reduce or occlude distal blood flow and

20 may not be tolerated by the patient.

Other methods have been proposed to improve absorption of locally injected drugs to treat stenoses. For example, U.S. Patent No.

5,197,946 to Tachibana, incorporated by reference, provides for

injection instruments with an ultrasonic oscillating element having a

25 proximal tubular part characterized by means for introducing medicinal

fluid or the like and an ultrasonic oscillator or connector which is

electrically connected to an ultrasonic oscillating element located at the

distal tubular part of the injection instrument. Use of such an apparatus

demonstrated remarkable improvements in the diffusion and penetration

30 in the area of injection compared with previous methods. However, this

-4-

method of Tachibana suffers from the disadvantage, as noted above, that drugs will only be momentarily available at the lesion site because blood flow will rapidly sweep the drugs downstream.

Another approach to improving drug uptake is disclosed in U.S. Patent No. 5,499,971 to Shapland et al, incorporated by reference. Shapland discloses a drug delivery apparatus and method for iontophoretically delivering a drug locally to an internal body tissue. The iontophoretic delivery apparatus and method include a current source producing a net flow of current in a desired direction with high frequency wave forms that enhance delivery and minimize side effects typically associated with iontophoresis. The Shapland patent contemplates positioning a drug delivery device in a body passageway or within body tissue and then selectively introducing a selected drug so that it is iontophoretically transported across a drug transport wall of the device for direct contact with the passageway wall or body tissue. However, the method of Shapland suffers from the defects mentioned above, namely that blood flow will sweep any injected drugs rapidly downstream.

A local drug delivery device designed for intravascular application directly after percutaneous angioplasty, and that allows perivascular blood deposition, has been suggested. Gonschior P, Goetz A, Huehns T, Hofling B, **A new catheter for prolonged local drug application**, *Coronary Artery Disease* 1995, 6:329-334, incorporated by reference. This document discussed a local delivery device with a polyethylene catheter possessing a central lumen for a guide wire and six needles positioned symmetrically. With the catheter placed in the vessel lumen, the needles were designed to be advanced by a mechanism at the distal end thus extending the needles laterally at the proximal tip. The needles were preshaped so that they could penetrate the vascular wall, and drugs could be injected in the perivascular tissue. This system was compared to use of a modified porous balloon design in Gonschior P,

Pahl C, Huehns T, Gerheuser F, Erdemci A, Larisch K, Dellian M, Deil S, Goetz A, Lehr H, and Hofling B, **Comparison of local intravascular drug-delivery catheter systems**, *American Heart Journal*, **130**:61-1174-81, 1995, incorporated by reference. Experimental data showed that ten-fold more drug could be achieved in the vessel wall with the needle injection catheter, compared with the porous balloon delivery. However, this method suffers from some difficulties with diffusing and penetrating of the injected medications into the body tissues.

Similarly, U.S. Patent No. 5,538,504 to Linden et al., incorporated by reference, shows another type of needle injection catheter having a puncturing element for puncturing the inner wall of a vessel and then injecting a selected drug. As noted above, such needle injection catheters suffer from some difficulties with diffusing and penetrating of the injected medications into the body tissues.

Furthermore, current treatments for cancer tumors or other undesirable growths often focus on systemic administration of various medications, as opposed to a local treatment. However, administering levels of those medications high enough to achieve effective bioavailability at the tumor location can often lead to undesirable side effects for a patient.

There is therefore a need for an improved intravascular catheter designed to facilitate distribution and diffusion of therapeutic agents delivered locally to treat stenoses or undesired growths such as tumors.

Summary of the Invention

The invention relates to an apparatus for delivering a medicament into an injection site in or beyond a vessel wall or vessel obstruction comprising: an intraluminal catheter containing, internal to the catheter: at least one puncturing element that is laterally extendable to the catheter longitudinal axis at the distal end of the catheter; an ultrasound emitter located in the proximity of the extendable puncturing element(s);

-6-

and an introducer element that introduces the medicament into an injection site that is in or beyond the vessel wall, but within a portion of the vessel wall that has been penetrated by the puncturing element.

5 The invention also relate to methods for treating a stenosis or obstruction in a vessel comprising introducing an intraluminal catheter into the vessel, wherein the catheter contains, internal to the catheter, at least one puncturing element, an ultrasound emitter located in the proximity of the puncturing element(s), and an introducer element that introduces the medicament into an injection site in or beyond the vessel
10 wall, but within a portion of the vessel wall that has been penetrated by the puncturing element; introducing a drug using the introducer element into the injection site; and irradiating the injection site with ultrasound using the emitter.

The invention additionally relates to methods for creating a
15 stenosis or obstruction in a vessel comprising introducing an intraluminal catheter into the vessel, wherein the catheter contains, internal to the catheter, at least one puncturing element, an ultrasound emitter located in the proximity of the puncturing element(s), and an introducer element that introduces the medicament into an injection site in or beyond the
20 vessel wall, but within a portion of the vessel wall that has been penetrated by the puncturing element; introducing a drug using the introducer element into the injection site; and irradiating the injection site with ultrasound using the emitter.

25 **Brief Description of the Drawings**

These and other features and advantages of the present invention will become more apparent to those skilled in the art from the following detailed description in conjunction with the appended drawings in which:

30 Figure 1 shows a catheter structure according to the invention.

Figure 2 shows a catheter structure according to the invention.

-7-

Figure 3 shows a catheter structure according to the invention.

Figure 4 shows a catheter system layout according to the invention.

5 Figure 5 shows an cross section of a catheter structure according to the invention.

Figure 6 shows a catheter structure according to the invention.

Figure 7 shows an cross section of a catheter structure according to the invention.

Figure 8 shows a catheter structure according to the invention.

10 Figure 9 shows a catheter structure according to the invention.

Figure 10 shows an cross section of a catheter structure according to the invention.

Figure 11 shows operation of an embodiment of the invention.

Figure 12 shows operation of an embodiment of the invention.

15 Figure 13 shows operation of an embodiment of the invention.

Figure 14 shows ultrasound emitters according to the invention.

Figure 15 shows operation of an embodiment of the invention.

Figure 16 shows operation of an embodiment of the invention.

Figure 17 shows operation of an embodiment of the invention.

20 Figure 18 shows operation of an embodiment of the invention.

Figure 19 shows operation of an embodiment of the invention.

Figure 20 shows operation of an embodiment of the invention.

Figure 21 shows an embodiment of the invention for treating a tumor.

25 Figure 22 shows an embodiment of the invention for treating a tumor.

Figure 23 shows an embodiment of the invention for treating a tumor.

Figure 24 shows a structure of esophageal varices.

30 Figure 25 shows an embodiment of the invention for treating esophageal varices.

-8-

Figure 26 shows an embodiment of the invention for treating a tumor.

Figure 27 shows an embodiment of the invention for treating a tumor.

5 Figure 28 shows an embodiment of the invention for treating a tumor.

Figure 29 shows an embodiment of the invention for treating a tumor.

10 Figure 30 shows an embodiment of the invention for treating a tumor.

Figure 31 shows an embodiment of the invention showing application of ultrasound external to a body part.

DETAILED DESCRIPTION

15 In one aspect of the invention, there is disclosed an apparatus for delivering a medicament into an injection site in or beyond a vessel wall or vessel obstruction comprising: an intraluminal catheter containing, internal to the catheter: at least one puncturing element that is laterally extendable to the catheter longitudinal axis at the distal end of the
20 catheter; an ultrasound emitter located in the proximity of the extendable puncturing element(s); and an introducer element that introduces the medicament into an injection site that is in or beyond the vessel wall, but within a portion of the vessel wall that has been penetrated by the puncturing element.

25 In another aspect of the invention, the apparatus further comprises an element to extend and retract the puncturing element such that when the puncturing element is retracted, the catheter outside surface is relatively smooth and can be moved within a vessel lumen, and such that, when the puncturing element is extended, it extends
30 sufficiently laterally to the catheter surface to penetrate into or beyond the vessel wall.

In yet another aspect of the invention, the apparatus further comprises an electrical connector element to provide power to the ultrasound emitter. In still another aspect of the invention, the apparatus further comprises at least one element to generate an ultrasonic signal external to the body and connected to the emitter by a connection mechanism.

In another aspect of the invention, the apparatus further comprises an element to connect a container of medicament to the introducer element such that the medicament can be injected through the introducer element into the injection site.

Another aspect of the invention relates to the apparatus wherein an element to measure temperature is provided in the proximity of the ultrasound emitter. Yet another aspect of the invention relates to the apparatus wherein the emitter has a cylindrical geometry. Still another aspect of the invention relates to the apparatus wherein geometry of the emitter is a hollow cylinder. Another aspect of the invention relates to the apparatus wherein the emitter is hemispherical. Still another aspect of the invention relates to the apparatus wherein the emitter is flat plate. Yet another aspect of the invention relates to the apparatus wherein the emitter is round. Another aspect of the invention relates to the apparatus wherein the emitter is a polygon.

In another embodiment of the invention, the invention relates to an apparatus wherein the catheter outside diameter is between 1.0 mm and 3.0 mm. Another aspect of the invention relates to the apparatus wherein the catheter size is between 3.5 french and 6.0 french.

Yet another aspect of the invention relates to the apparatus wherein the puncturing element and the introducer element are the same. In another aspect of the invention, the invention relates to the apparatus wherein the puncturing element and the introducer element are a hollow needle. In still another aspect of the invention relates to the apparatus wherein the needle outside diameter is approximately 0.250

-10-

mm. Still another aspect of the invention relates to the apparatus wherein the needle is stainless steel. Another aspect of the invention relates to the apparatus wherein the needle is NiTi.

5 In a further aspect of the invention, the invention relates to the apparatus wherein the needle is pre-shaped to extend in an angular manner. Another aspect of the invention relates to the apparatus wherein the extension angle is approximately 15-20°.

10 Yet another aspect of the invention relates to the apparatus wherein the number of puncturing elements is between 1 and approximately 10,000. Another aspect of the invention relates to the apparatus wherein the number of puncturing elements is between 2 to 30. Still another aspect of the invention relates to the apparatus wherein the number of puncturing elements is between 3 and 6.

15 Another aspect of the invention relates to the apparatus wherein the vessel wall is an artery, a urethra, an esophagus, a colon, a rectum, a bronchus, a trachea, or a bile duct. Yet another aspect of the invention relates to the apparatus wherein the vessel is a human vessel.

20 Still another aspect of the invention relates to the apparatus wherein the obstruction is a thrombus. Another aspect of the invention relates to the apparatus wherein the obstruction is an atherosclerotic plaque.

25 In another aspect of the invention, the invention relates to the apparatus wherein the emitter is equi-positional with respect to the injection site. Another aspect of the invention relates to the apparatus wherein the emitter is distal with respect to the injection site. Yet another aspect of the invention relates to the apparatus wherein the emitter is proximal with respect to the injection site.

30 Still another aspect of the invention relates to the apparatus wherein the ultrasound frequency is between 200KHz and 1.3MHz. Yet another aspect of the invention relates to the apparatus further comprising a guidewire.

-11-

Another aspect of the invention relates to the apparatus wherein the ultrasound emitter is located within the catheter. Yet another aspect of the invention relates to the apparatus wherein the ultrasound emitter is located external to the catheter.

5 In another embodiment, the invention relates to a method for treating a stenosis or obstruction in a vessel comprising introducing an intraluminal catheter into the vessel, wherein the catheter contains, internal to the catheter, at least one puncturing element, an ultrasound emitter located in the proximity of the puncturing element(s), and an
10 introducer element that introduces the medicament into an injection site that is in or beyond the vessel wall, but within a portion of the vessel wall that has been penetrated by the puncturing element; introducing a drug using the introducer element into the injection site; and irradiating the injection site with ultrasound using the emitter.

15 Another aspect of the invention relates to the method wherein the puncturing element and the introducer element are the same. Still another aspect of the invention relates to the method wherein the puncturing element and the introducer element are a hollow needle. Yet another aspect of the invention relates to the method wherein the
20 vessel wall is an artery, a urethra, an esophagus, a colon, a rectum, a bronchus, a trachea, or a bile duct.

Another aspect of the invention relates to the method wherein the vessel is a human vessel. Another aspect of the invention relates to the method wherein the obstruction is a thrombus. Another aspect of the
25 invention relates to the method wherein the obstruction is an atherosclerotic plaque.

30 Still another aspect of the invention relates to the method wherein the emitter is equipositional with respect to the injection site. Another aspect of the invention relates to the method wherein the emitter is distal with respect to the injection site. Yet another aspect of the invention relates to the method wherein the emitter is proximal with respect to the

-12-

injection site. Another aspect of the invention relates to the method wherein the ultrasound emitter is located external to the catheter.

5 In another embodiment of the invention, the invention relates to a method for creating a stenosis or obstruction in a vessel comprising introducing an intraluminal catheter into the vessel, wherein the catheter contains, internal to the catheter, at least one puncturing element, an ultrasound emitter located in the proximity of the puncturing element(s), and an introducer element that introduces the medicament into an injection site in or beyond the vessel wall, but within a portion of the
10 vessel wall that has been penetrated by the puncturing element; introducing a drug using the introducer element into the injection site; and irradiating the injection site with ultrasound using the emitter.

Another aspect of the invention relates to the method wherein the puncturing element and the introducer element are the same. Still
15 another aspect of the invention relates to the method wherein the puncturing element and the introducer element are a hollow needle. Yet another aspect of the invention relates to the method wherein the vessel wall is an artery, a urethra, an esophagus, a colon, a rectum, a bronchus, a trachea, or a bile duct.

20 Another aspect of the invention relates to the method wherein the vessel is a human vessel. Another aspect of the invention relates to the method wherein the obstruction is a thrombus. Another aspect of the invention relates to the method wherein the obstruction is an atherosclerotic plaque.

25 Still another aspect of the invention relates to the method wherein the emitter is equi-positional with respect to the injection site. Another aspect of the invention relates to the method wherein the emitter is distal with respect to the injection site. Yet another aspect of the invention relates to the method wherein the emitter is proximal with respect to the
30 injection site. Another aspect of the invention relates to the method wherein the ultrasound emitter is located external to the catheter.

-13-

In another aspect of the invention, the invention relate to the method wherein the vessel supplies blood to or from a tumor. In another aspect of the invention, the invention relate to the method wherein the ultrasound emitter is located externally to a body part containing the vessel wall.

The inventors have discovered that drug diffusion and distribution may be markedly and unexpectedly improved by introducing treatment drugs into an area near or in a vessel wall through a puncturing element or elements located at the distal end of a catheter and then irradiating that area with ultrasound.

Figure 1 shows a portion of a catheter according to the invention. Distal end of catheter 104 is located at the distal end of catheter body 103. The distal end of catheter 104 includes puncturing element port 101, ultrasound emitter 102, and guidewire 105. Guidewire 105 passes through catheter body 103 and serves to guide the catheter during insertion.

Figure 2 shows another embodiment of the invention. Catheter body 203 possesses a distal end and shows another view of puncturing element 201, ultrasound emitter 202, and protruding through the end of catheter body 203 is guidewire 205.

Figure 3 shows another view of the catheter according to the invention. Catheter body 303 possesses a distal portion. The distal portion has puncturing element 301, ultrasound emitter 302 and puncturing elements 306 that comprise drug needles. The drug needles in Figure 3 are shown in the extended position.

Figure 4 shows the catheter system layout according to an embodiment of the invention. Catheter body 403 possesses a distal portion 404 and a proximal portion possessing a junction block 410. Protruding from the junction block are drug lumen 415 possessing a drug delivery container 414. Also extending from junction block 410 is a guidewire port 416 possessing guidewire 405 running through the

-14-

guidewire port. Additionally, needle extender/retractor device 413 passes through junction block 410. Ultrasound generator 411 is connected to electrical power connector 412 then to the catheter itself through junction block 410. While Figure 4 shows one embodiment of a catheter system according to the invention, other arrangements of the various system components will occur to one of skill in the art. For example, instead of a guidewire based system, the present invention can be practiced in a monorail configuration as well.

Figure 5 shows a cross-section of an embodiment of the invention. Shown is catheter outside body 503 containing within puncturing elements 506, wherein the puncturing elements are needles possessing needle drug lumen 518. Within the catheter outside body 503 is electronics lumen 524. Contained within electronics lumen 524 are ultrasound power wires 520 and thermocouple wires 522. Contained within electronics lumen 524 is catheter inner guidewire sleeve 519.

Figure 6 shows the distal tip 603 of a catheter according to the invention. The distal tip of the catheter 603 possesses puncturing elements 604 that are vibrating needles that can be extended and retracted 605. Distal tip 603 possesses vibrating element 606 located in distal tip 603 that induces puncturing element 604 to vibrate. Drug 607 can be infused through puncturing element 604 and introduced into a into or around vessel wall or a lumen area. Puncturing element(s) 604 may be connected to the proximal end of the catheter directly or via a manifold.

Figure 7 shows another embodiment of the invention having distal end of a catheter 701 containing within lumen space 702 a puncturing element of a hollow vibrating needle 703 for use in introducing medication or other substances.

Figure 8 shows yet another embodiment of the invention. Distal tip of catheter 803 possesses puncturing element 802 and a diagnostic

-15-

ultrasound array 805. Also included in the distal portion of catheter 803 is therapeutic ultrasound emitter 806.

Figure 9 shows yet another embodiment of the invention. Shown is proximal end of catheter 903. The proximal end of catheter 903 possesses puncturing element 904 that are drug delivery needles, ultrasound emitter 905, and element for diagnostic echo imaging 906.

Figure 10 shows a cross-section of an embodiment of the invention possessing distal end of catheter 1003, passages for puncturing element 1007 and ultrasound emitter 1005.

Figure 11 shows another embodiment of the invention. Puncturing element 1102 is contained within distal end of catheter 1103, and is extended into vessel wall 1104 puncturing the wall at 1105. Drug 1106 is injected into the vessel wall area 1104. Ultrasound emitter 1107 is positioned such that it irradiates injected drug 1106 as shown by element 1108. This addition of ultrasound energy 1108 delivered proximal to the needle injection site 1106 further mixes, delivers and/or can activate the drug.

Figure 12 shows another embodiment of the invention. Distal end of catheter 1201 contains puncturing element 1203 used to deliver drug 1204 into vessel wall 1202. Ultrasound emitter 1205 is positioned such that it irradiates in area of drug injection 1204. The angle of the emitter 1205 as described by angle 1208 is measured based on the distance 1207 between the center of the transmitter 1205 and the injection site 1204, and by the distance between the center of the emitter 1205 and the puncturing element 1203. Distance 1206 represents the lateral distance from the ultrasound element to the delivery site. Element 1207 represents the actual distance from the puncturing element tip to the center of the ultrasound element.

Figure 13 shows an embodiment of the invention, designed to illustrate positioning of the ultrasonic emitter proximally and within the treatment catheter, as opposed to Figure 12 where the emitter is located

-16-

distally and within the catheter. Distal end of catheter 1301 is inserted such that puncturing element 1303 penetrates vessel wall 1302, whereupon drug 1304 is injected into the vessel wall area. Angle 1308 describes the angle from perpendicular formed by emitter 1305. This angle 1308 is the angle between center axis of the ultrasound element in this embodiment and aligned perpendicular to the catheter axis contained in the plane defined by the puncture element and the drug delivery area. Element 1306 describes the lateral distance from the ultrasound element to the drug delivery site. Element 1307 describes the axial distance from the puncture element tip to the center of the ultrasound emitter 1305.

Figure 14 shows embodiments of ultrasonic emitters according to the invention. Element 1401 is a circular emitter, element 1402 is a square emitter, and element 1403 is an octagonal emitter.

Figure 15 shows an embodiment of the invention. Distal end of catheter 1501 contains puncturing element 1503 which is puncturing vessel wall 1502. Drug 1504 has been injected into vessel wall 1502. In this embodiment in contrast to the embodiment demonstrated in Figure 11 or Figure 12, the emitter 1505 is located equipositionally within the catheter 1501 with respect to drug injection site 1504.

Figure 16 shows an embodiment of the invention having multiple puncturing elements. Distal end of catheter 1601 contains puncturing elements 1604 used to puncture vessel walls 1602. Drug injection sites 1606 are then irradiated by equipositionally located emitter 1605. Emitter 1605 is an example of a hollow cylinder emitter geometry.

Figure 17 shows an embodiment of the invention. Distal end of catheter 1701 contains puncturing element 1702 which is used to introduce drug injection site 1703. Catheter 1702 is passed within hollow cylinder emitter 1704. Emitter 1704 is excited such that the primary vibration mode directs the ultrasound forward along the axis of the catheter 1701 and puncturing element 1702.

-17-

Figure 18 shows another embodiment to the claimed invention. Catheter 1801 contains puncturing element 1802 used to introduce drug injection site 1803. Emitter 1804 is located such that puncturing element 1802 can pass through the distal portion of catheter 1801, and can also irradiate along the axis of the catheter 1801 and puncturing element 1802. This embodiment shows that puncturing element 1802 need not be moved along a particular central axis.

Ultrasound emitters according to the invention can be of any conventional configuration designed to be used in intravascular application. Acceptable emitter geometries include, but are not limited to hollow cylinder, hemispherical, flat plate, round, and polygon geometries. Suitable emitter geometries are discussed, for example, in U.S. Patent No. 5,362,309 and in U.S. Patent No. 5,197,946, both of which are incorporated by reference. Multiple emitters may be included in the catheter system. For example, it is possible to have one or more diagnostic arrays in addition to one or more therapeutic arrays in a catheter system. Such arrays can be located either proximally, distally, or in equi-position with respect to the puncturing mechanism. Additionally, the emitter may be located within the catheter, or it may be located externally to the catheter. For example, the emitter may be externally located in another catheter or the emitter may be located externally to a patient being treated. Typical ultrasound operating frequencies for emitters according to the invention are from 200 kilohertz to 1.3 megahertz.

The puncturing element(s) according to the invention can be laid out according to the Figures discussed above and/or according to the teachings in Gonschior P, Goetz A, Huehns T, Höfling B, **A new catheter for prolonged local drug application, *Coronary Artery Disease* 1995, 6:329-334**, Gonschior P, Pahl C, Huehns T, Gerheuser F, Erdemci A, Larisch K, Dellian M, Deil S, Goetz A, Lehr H, and Hofling B, **Comparison of local intravascular drug-delivery catheter**

systems, *American Heart Journal*, **130**:61-1174-81, 1995; Höfling B., Huehns T., Gonschior P., **Needle Injection Catheter**, *Semin Intervent Cardiol* 1996, **1**:44, each of which is hereby incorporated by reference.

5 Alternate puncturing element arrangements, such as the needle arrangements disclosed in U.S. Patent No. 5,538,504, are also useful within the scope of this invention so long as they provide a puncturing mechanism for penetrating into the vessel wall. Alternate puncture element structures might also include pointed or sharp puncturing elements used to score a vessel wall and permit increased uptake of
10 medication into the vessel wall. For example, balloons studded with sharp points may be used to incise a vessel wall, followed by introduction of a drug into the area near or in the incision and subsequent or contemporaneous application of ultrasound.

15 However, use of "vibrating" needles, as disclosed in U.S. Patent No. 5,538,504, will generally not be successful in achieving delivery of therapeutic or imaging amounts of ultrasound to a distal injection site. The very thin needles disclosed in the '504 patent need to remain flexible to be introduced through a catheter and deliver a drug. Such thin and flexible needles are not efficient; i.e. they lose a lot of
20 ultrasound energy as they transmit the sound over the length of the catheter. It is unlikely that such a catheter would be able to transmit enough externally generated ultrasound to a treatment site for therapeutic or imaging purposes. Additionally, such needles will, in practice, fatigue harden when used with ultrasound, and thus
25 experience material failures.

Conversely, if the needles are made stiff enough to efficiently transmit externally generated ultrasound, they will generally be too large in diameter to serve as flexible and retractable puncturing mechanisms. For example, in Ultrasound Angioplasty 155 (1996) (Robert J. Siegel,
30 ed. Kluwer Academic Publishers), hereby incorporated by reference, the vibrating wire is disclosed as being 1.6 mm in diameter at the distal end.

-19-

Therefore, after much research, the present inventors have concluded that vibrating wires with external emitters are significantly less useful than ultrasonic emitters located at the distal end of the catheter, or application of an externally applied ultrasound beam. Distally located emitters offer relatively high intensities of ultrasound emission at or near the treatment site, without the difficulties presented by ultrasonic or vibrating wires. Additionally, such a catheter architecture would be flexible enough to use in typical applications, such as coronary applications. Application of an externally applied ultrasound beam offers the possibility of using catheters with puncturing mechanisms that may be optimized for drug delivery together with easily adaptable external therapeutic ultrasound beam emitters.

When using needles as the puncturing elements, the needles should have a diameter suitable for drug delivery into the vessel walls or tissue surrounding the distal end of the catheter system when in use. Preferably the needle diameters should be approximately 0.25 millimeters. The needles may be made of materials known to be suitable by one of skill. Preferably the needles are made of stainless steel or NiTi. Needles may be designed to be flexible to facilitate their being extended and retracted through ports present in the distal end of the catheter. Typically, the needles will be preshaped and will have an extension angle of between 15 to 20 degrees.

The number of puncturing elements used in practicing the invention will vary according to the indication for treatment. For example, if the treating physician decides that more medication must be delivered to a treatment site, the physician may select a treatment catheter with additional puncturing elements. Conversely if less medication is needed, fewer puncturing elements may be included in the treatment catheter. Preferably the number of puncturing element ranges from 1 to approximately 10,000, more preferably from 2 to 30, and most preferably from 3 to 6. Often more puncturing elements will

-20-

be needed when the vessel in which the treatment catheter is being deployed is larger. For example, fewer puncturing elements may be needed in a arterial application than would be needed for an esophageal or a colon application.

5 Catheters according to the invention can be used to deliver a variety of drugs useful in treatment or therapy. A representative list of drugs useful in the practice of this invention is given in, but not limited to, the disclosure of U.S. Patent No. 5,538,504, especially in Table I. Drugs that create or cause or induce stenosis, stenotic lesions, thrombosis,
10 etc. are also examples of drugs useful according to the invention.

Catheters according to the invention can be used to deliver drugs between the inner and outer surfaces of a vessel wall, to the adventitial side or outer surface of a vessel wall, between the tissue surrounding a vessel wall and the outer surface of the vessel wall, or in other locations
15 that one of ordinary skill might determine to be appropriate delivery sites. One advantage of the catheter according to the invention is that the invention allows one who practices the invention more latitude in how drug is provided to a particular site. For example, drugs provided using a catheter according to the Gonschior techniques or the '504
20 patent require that a puncturing element actually penetrate to the site of desired drug delivery.

In contrast, the catheter according to the present invention need not penetrate completely to the site. Rather, ultrasound can be used to distribute the drug to the desired site after or in the course of its initial
25 introduction. Thus, for example, it may be possible to deliver drug to the tissue outside of a vessel wall without having to completely penetrate through the vessel wall with the puncturing element. Such a technique substantially reduces the possibility of undesirable internal bleeding caused by the puncturing of a vessel wall. Of course, it is possible for
30 one practicing this invention to penetrate completely through a vessel

-21-

wall with the puncturing element and then further distribute a drug using ultrasound if deemed appropriate.

Catheters according to the invention can be deployed in a variety of vessels in a body. Suitable vessels include, but are not limited to, the artery, the urethra, the esophagus, the colon, the rectum, the bronchial passages, the trachea, the bile duct, and other luminal spaces within the body.

It is surprising that catheters according to the invention can be expected to provide unexpectedly superior results as compared to prior art approaches. The catheters according to the invention may, for example, be used to clear obstructions within the vessels. This is generally accomplished by administering medication through the catheter and into the punctures created by the puncturing element. Ultrasound, emitted from the therapeutic ultrasound array or arrays, can then be used to increase uptake through diffusion, distribution, etc., of the medication introduced through the needles into the vessel wall.

Figure 19 illustrates the operation of an embodiment of the invention. Shown is distal end of catheter 1903 with puncturing element 506 extended. Puncturing elements 506 are used to inject drug 1907 into vessel wall 1908. Also shown is thermocouple sensor 1921.

Figure 20 shows an embodiment of the invention. Shown is distal end of catheter 2003 with puncturing elements 2006. As Figure 20 suggests the puncturing elements 2006 may be withdrawn when activating or incorporating injected drug 2007B into the vessel walls 2008. Ultrasound emitter 2002 is used to radiate ultrasound energy 2009 to cause injected drug 2007B to diffuse in the vessel walls due to the influence of ultrasound energy 2009.

Catheters according to the invention can also be used to create stenosis or thrombi. Such stenoses or thrombi can be valuable in treatment of various diseases, such as cancers, that are characterized by undesirable tissue growth. For example, the catheter according to

-22-

the invention could be used to deliver thrombin into the arterial wall of a vessel which is feeding into a tumor, thus cutting off blood supply to the tumor and causing tumor necrosis. Additionally, the catheter according to the invention can be used to create chemical and/or physical damage to a vessel wall. Such damage may block flow through the vessel by creating or initiating a stenosis or a thrombus, depending on the methods used and the nature of the vessel.

These techniques can be used, for example, to deliver drug into the hepatic artery wall for treatment of liver cancer, or could be used to deliver drug into a brain artery wall for treatment of a brain tumor. Similar techniques could also be used to treat prostate cancer. Catheters according to the invention can additionally be used with or introduced using endoscopes, such as the endoscope used in urology or bronchus endoscopy, for example.

Figure 21 shows another embodiment of a catheter according to the invention possessing catheter body 2101, ultrasound horn emitter 2102 and drug introducing lumen 2103. Catheter 2101 can be introduced into tumor 2104.

Figure 22 shows one embodiment of the invention as applied to treatment of liver tumors. Catheter 2201 is inserted through the abdominal aorta 2202 and the hepatic artery 2203 to come to rest in or near hyper vascular hematoma 2206 in position 2204. Hematoma 2206 is present inside liver 2205.

Figure 23 shows another view of treatment of tumors showing distal catheter tip 2301 having emitter 2303 and puncturing elements 2302 protruding into arterial stenosis 2305. Puncturing elements 2302 inject drug 2304 into a vessel wall creating the stenosis 2305 proximal of tumor 2306.

Figure 24 shows an embodiment of the invention for treatment of esophageal varices can be used when varices 2402 are near the surface of esophagus 2401 near stomach 2404. In such situations, it is

-23-

possible for varices 2402 to begin bleeding significantly, as shown by element 2403, into esophagus 2401 and stomach 2404.

Figure 25 shows treatment of such conditions using a catheter according to the invention may be performed by introducing endoscope 2505 into esophagus 2501 and then introducing drug delivery and ultrasound, as shown by element 2506, according to the invention into the area of varices 2502. This prevents rupture 2507 of varices 2502 into esophagus 2501 or stomach 2504.

Figure 26 shows treatment of a colon cancer tumor (i.e., a tumor stenosis of the colon) 2602. Endoscope 2603 is inserted through rectum 2606 to come to rest near stenosis 2602. Catheter 2604 is extended through endoscope 2603 to come to rest inside of lumen 2601 and inside stenosis 2602. Puncturing elements 2605 are extended from catheter 2604 and can be used to introduce medication that is then subject to ultrasound emission from an emitter or emitters in catheter 2604.

Figure 23 shows another embodiment of the invention, for use in treatment of prostate cancer. Catheter 2304 is inserted proximal to prostate cancer tumor 2302 which is located proximal to bladder 2301. Needles 2303 are then extended from catheter 2304, drug is injected through puncturing elements 2303, and then ultrasound is emitted from the therapeutic emitter in catheter 2304.

Figure 28 shows yet another embodiment of the invention used in treatment of prostate cancer. Bladder 2801 is proximal to prostate tumor 2802, therapy catheter 2805 is introduced into the area in or near tumor 2802 whereupon puncturing elements 2806 are extended, drug is injected through puncturing elements 2806, and ultrasound is applied to further the therapy. Echo imaging device 2804 is inserted through rectum 2803 to image the procedure.

Figure 29 shows treatment of a liver tumor using a percutaneous method. Therapy catheter 2904 is inserted through surface of skin 2903

-24-

to come to rest in or near tumor 2901 inside of liver 2905. Echo imaging element 2902 is placed externally on skin 2903 to image the procedure.

Figure 30 shows another embodiment of the invention used for treating a tumor wherein distal tip of catheter 3003 is placed in or near tumor 3001, therapy ultrasound emitter 3004 is passed within catheter 3003 and puncturing elements 3005 are extended for introducing treatment medication, followed by ultrasound emission from emitter 3004.

Figure 31 shows another embodiment of the invention. Distal end of catheter 3101 contains puncturing element 3102 which is penetrating vessel wall 3103 and is used to introduce drug into drug injection site 3104. Externally applied ultrasound emitter 3106 is placed on surface of epidermis 3105 and ultrasound energy 3107 is applied externally to the body and then passing through to drug injection site 3104. This is an example of ultrasound energy being applied externally to a body.

It will be apparent to those skilled in the art that various modifications and variations can be made in the apparatus and methods of the present invention. Thus, it is intended that the present invention cover the modifications and variations of this invention provided they come within the scope of the appended claims and their equivalents.

CLAIMS

1. An apparatus for delivering a medicament into an injection site in or beyond a vessel wall or vessel obstruction comprising:

5 an intraluminal catheter containing, internal to the catheter:

a. at least one puncturing element that is laterally extendable to the catheter longitudinal axis at the distal end of the catheter;

b. an ultrasound emitter located in the proximity of the extendable puncturing element(s); and

10 c. an introducer element that introduces the medicament into an injection site that is in or beyond the vessel wall, but within a portion of the vessel wall that has been penetrated by the puncturing element.

2. The apparatus of claim 1, further comprising an element to extend and retract the puncturing element such that when the puncturing element is retracted, the catheter outside surface is relatively smooth and can be moved within a vessel lumen, and such that, when the puncturing element is extended, it extends sufficiently laterally to the catheter surface to penetrate into or beyond the vessel wall.

20 3. The apparatus of claim 1, further comprising an electrical connector element to provide power to the ultrasound emitter.

25 4. The apparatus of claim 1, further comprising at least one element to generate an ultrasonic signal external to the body and connected to the emitter by a connection mechanism.

30 5. The apparatus of claim 1, further comprising an element to connect a container of medicament to the introducer element such that the medicament can be injected through the introducer element into the injection site.

-26-

6. The apparatus of claim 1 wherein an element to measure temperature is provided in the proximity of the ultrasound emitter.

5 7. The apparatus claim 1 wherein the emitter has a cylindrical geometry.

8. The apparatus of claim 4 wherein geometry of the emitter is a hollow cylinder.

10 9. The apparatus of claim 1 wherein the emitter is hemispherical.

10. The apparatus of claim 1 wherein the emitter is flat plate.

15 11. The apparatus of claim 1 wherein the emitter is round.

12. The apparatus d of claim 1 wherein the emitter is a polygon.

20 13. The apparatus of claim 1 wherein the catheter outside diameter is between 1.0 mm and 3.0 mm.

14. The apparatus of claim 1 wherein the catheter size is between 3.5 french and 6.0 french.

25 15. The apparatus of claim 1, wherein the puncturing element and the introducer element are the same.

30 16. The apparatus of claim 15, wherein the puncturing element and the introducer element are a hollow needle.

-27-

17. The apparatus of claim 16 wherein the needle outside diameter is approximately 0.250 mm.

5 18. The apparatus of claim 15 wherein the needle is stainless steel.

19. The apparatus of claim 15 wherein the needle is NiTi.

10 20. The apparatus of claim 15 wherein the needle is pre-shaped to extend in an angular manner.

21. The apparatus of claim 15 wherein the extension angle is approximately 15-20°.

15 22. The apparatus of claim 1 wherein the number of puncturing elements is between 1 and approximately 10,000.

20 23. The apparatus of claim 20, wherein the number of puncturing elements is between 2 to 30.

24. The apparatus of claim 21, wherein the number of puncturing elements is between 3 and 6.

25 25. The apparatus of claim 1 wherein the vessel wall is an artery, a urethra, an esophagus, a colon, a rectum, a bronchus, a trachea, or a bile duct.

30 26. The apparatus of claim 1 wherein the vessel is a human vessel.

-28-

27. The apparatus of claim 1 wherein the obstruction is a thrombus.

28. The apparatus of claim 1 wherein the obstruction is an atherosclerotic plaque.

29. The apparatus of claim 1 wherein the emitter is equipositional with respect to the injection site.

30. The apparatus of claim 1 wherein the emitter is distal with respect to the injection site.

31. The apparatus of claim 1 wherein the emitter is proximal with respect to the injection site.

32. The apparatus of claim 1 wherein the ultrasound frequency is between 200KHz and 1.3MHz.

33. The apparatus of claim 1 further comprising a guidewire.

34. The apparatus of claim 1, wherein the ultrasound emitter is located within the catheter.

35. The apparatus of claim 1, wherein the ultrasound emitter is located external to the catheter.

36. The apparatus of claim 33, wherein the ultrasound emitter is located externally to a body part containing the vessel wall.

37. A method for treating a stenosis or obstruction in a vessel comprising

-29-

5 a. introducing an intraluminal catheter into the vessel, wherein the catheter contains, internal to the catheter, at least one puncturing element, an ultrasound emitter located in the proximity of the puncturing element(s), and an introducer element that introduces the medicament into an injection site in or beyond the vessel wall, but within a portion of the vessel wall that has been penetrated by the puncturing element;

b. introducing a drug using the introducer element into the injection site; and

10 c. irradiating the injection site with ultrasound using the emitter.

15 38. The method of claim 35, wherein the puncturing element and the introducer element are the same.

39. The method of claim 35, wherein the puncturing element and the introducer element are a hollow needle.

20 40. The method of claim 35 wherein the vessel wall is an artery, a urethra, an esophagus, a colon, a rectum, a bronchus, a trachea, or a bile duct.

25 41. The method of claim 35 wherein the vessel is a human vessel.

42. The method of claim 35 wherein the obstruction is a thrombus.

30 43. The method of claim 35 wherein the obstruction is an atherosclerotic plaque.

-30-

44. The method of claim 35 wherein the emitter is equipositional with respect to the injection site.

5 45. The method of claim 35 wherein the emitter is distal with respect to the injection site.

46. The method of claim 35 wherein the emitter is proximal with respect to the injection site.

10 47. The method of claim 35, wherein the ultrasound emitter is located external to the catheter.

48. A method for creating a stenosis or obstruction in a vessel comprising

15 a. introducing an intraluminal catheter into the vessel, wherein the catheter contains, internal to the catheter, at least one puncturing element, an ultrasound emitter located in the proximity of the puncturing element(s), and an introducer element that introduces the medicament into an injection site in or beyond the vessel wall, but within
20 a portion of the vessel wall that has been penetrated by the puncturing element;

b. introducing a drug using the introducer element into the injection site; and

25 c. irradiating the injection site with ultrasound using the emitter.

49. The method of claim 46, wherein the puncturing element and the introducer element are the same.

30 50. The method of claim 47, wherein the puncturing element and the introducer element are a hollow needle.

-31-

51. The method of claim 46 wherein the vessel wall is an artery, a urethra, an esophagus, a colon, a rectum, a bronchus, a trachea, or a bile duct.

5 52. The method of claim 46 wherein the vessel is a human vessel.

53. The method of claim 46 wherein the obstruction is a thrombus.

10

54. The method of claim 46 wherein the obstruction is a stenosis.

15 55. The method of claim 46 wherein the emitter is equipositional with respect to the injection site.

56. The method of claim 46 wherein the emitter is distal with respect to the injection site.

20 57. The method of claim 46 wherein the emitter is proximal with respect to the injection site.

58. The method of claim 46, wherein the ultrasound emitter is located external to the catheter.

25

59. The method of claim 46, wherein the vessel supplies blood to or from a tumor.

30 60. The method of claim 46, wherein the ultrasound emitter is located externally to a body part containing the vessel wall.

1/12

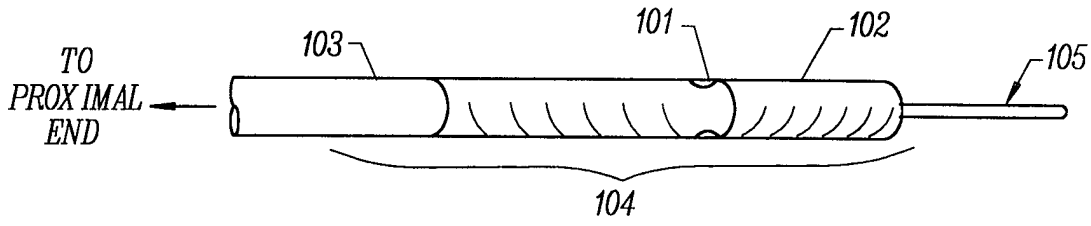

FIG. 1

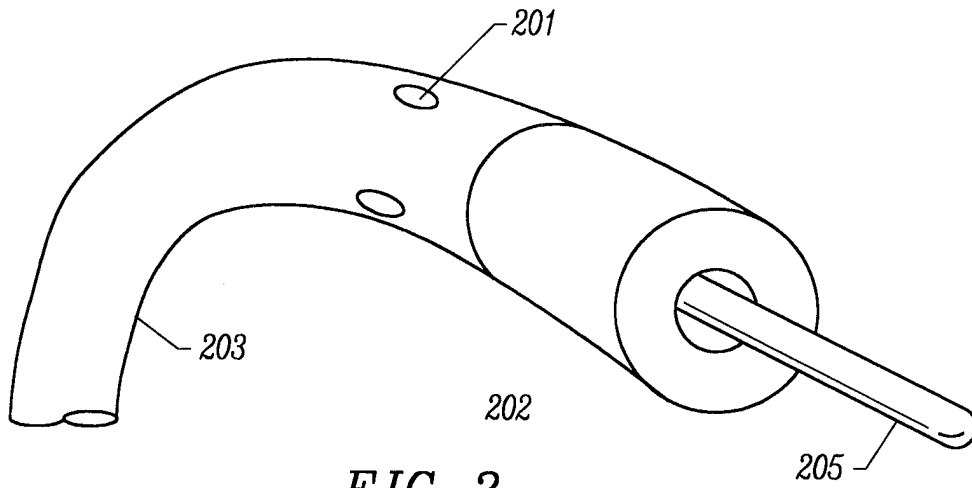

FIG. 2

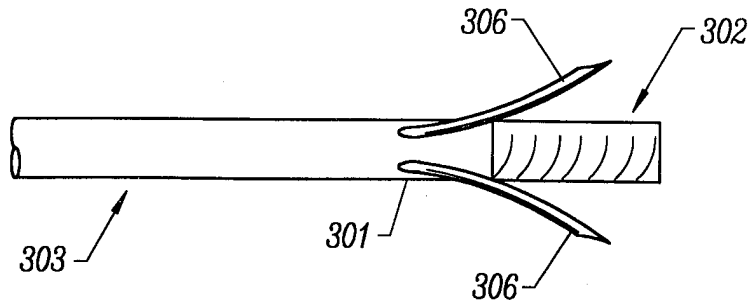

FIG. 3

FIG. 4

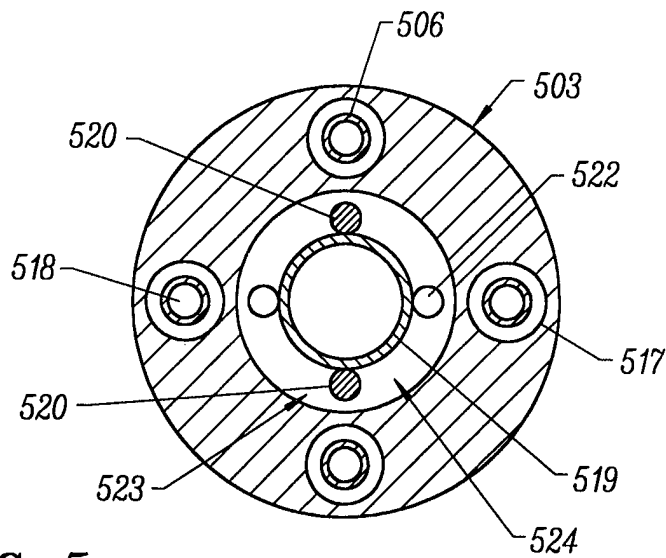
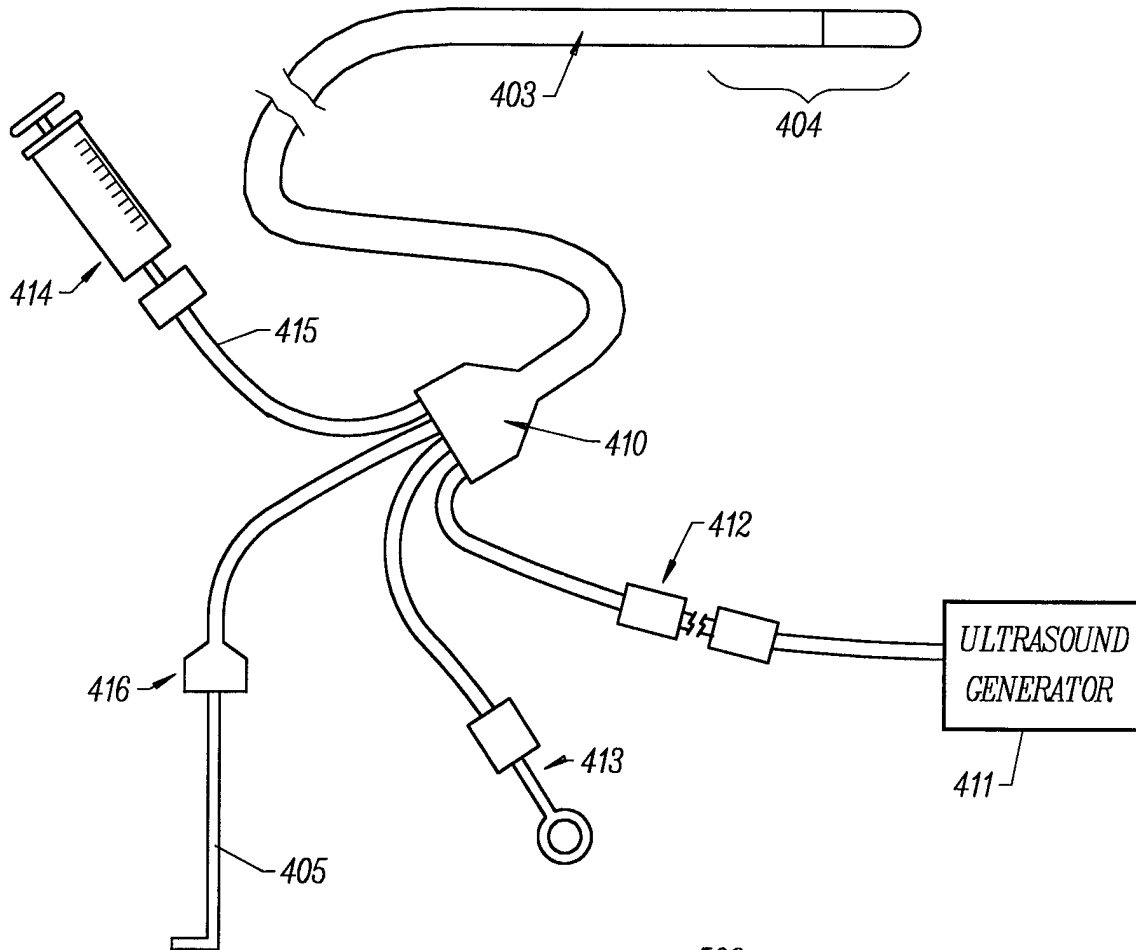

FIG. 5

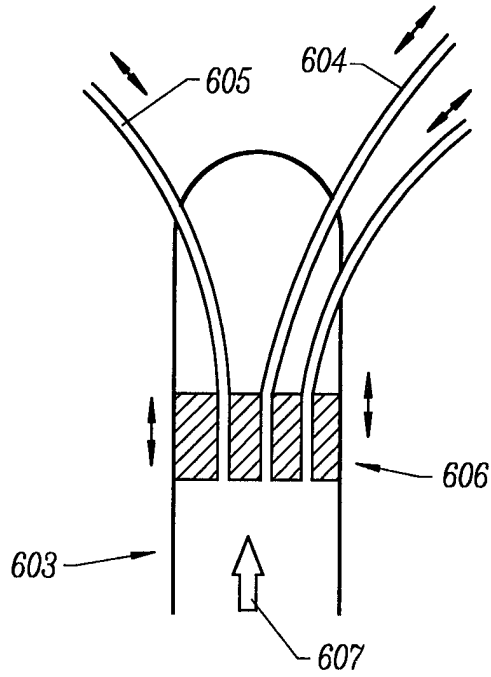

FIG. 6

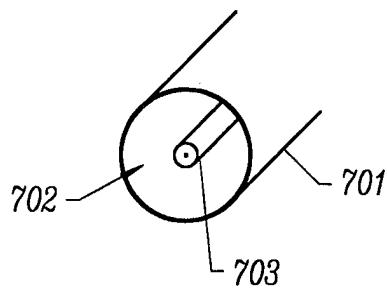

FIG. 7

4/12

FIG. 8

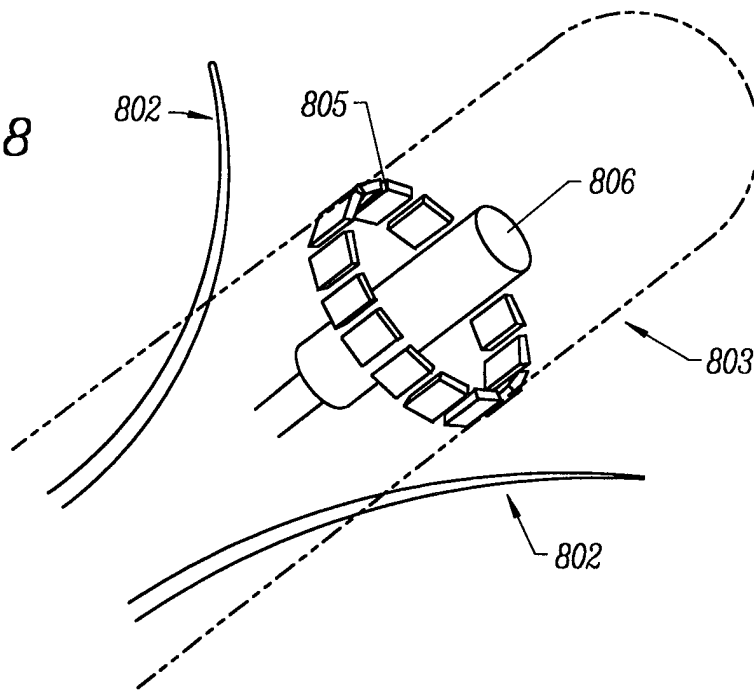

FIG. 9

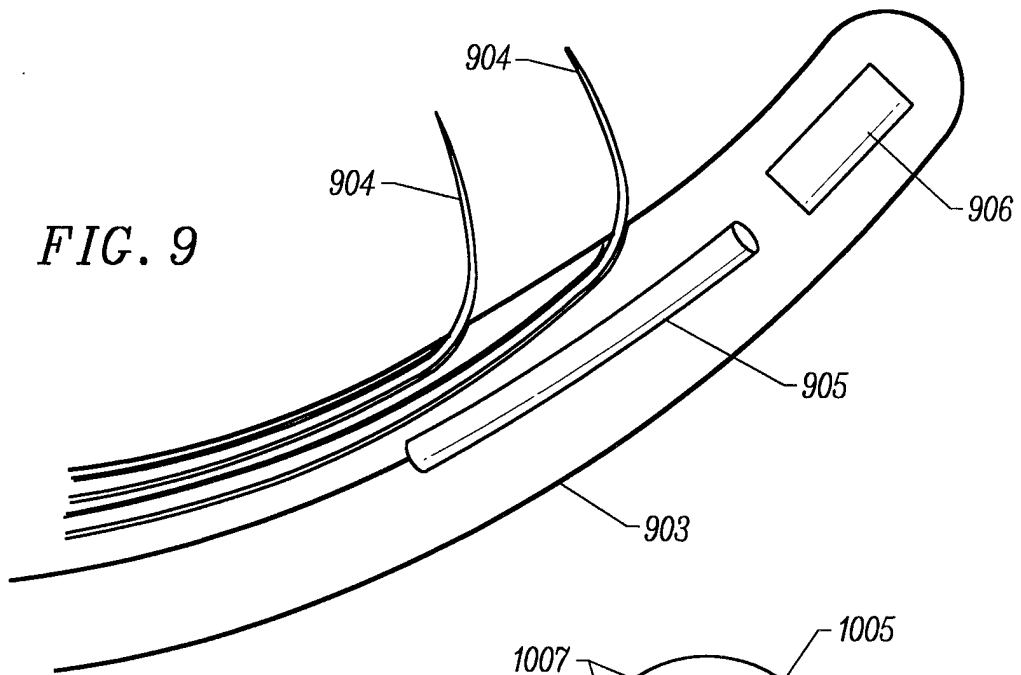
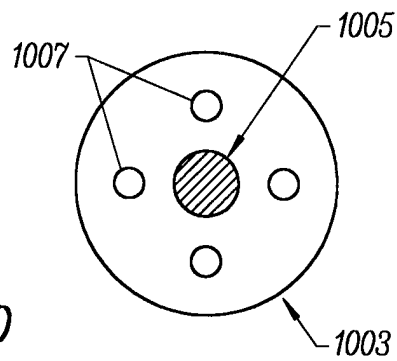

FIG. 10



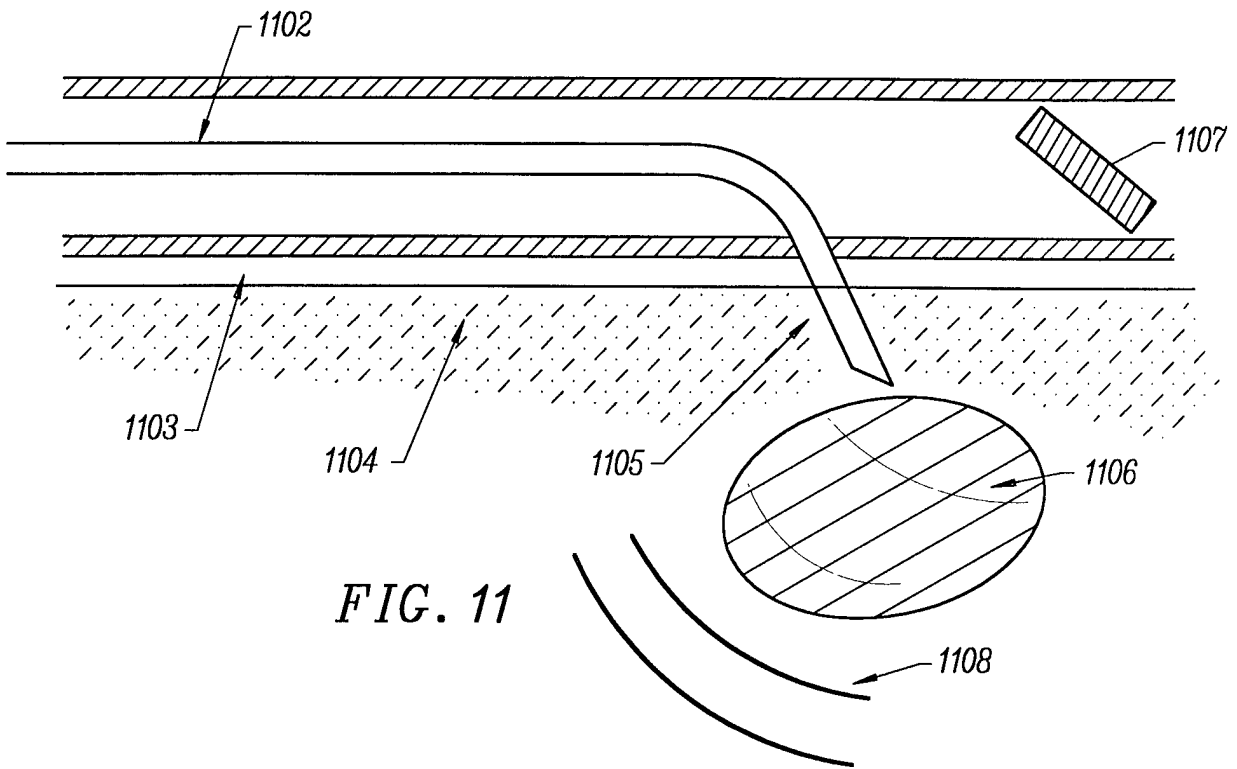

FIG. 11

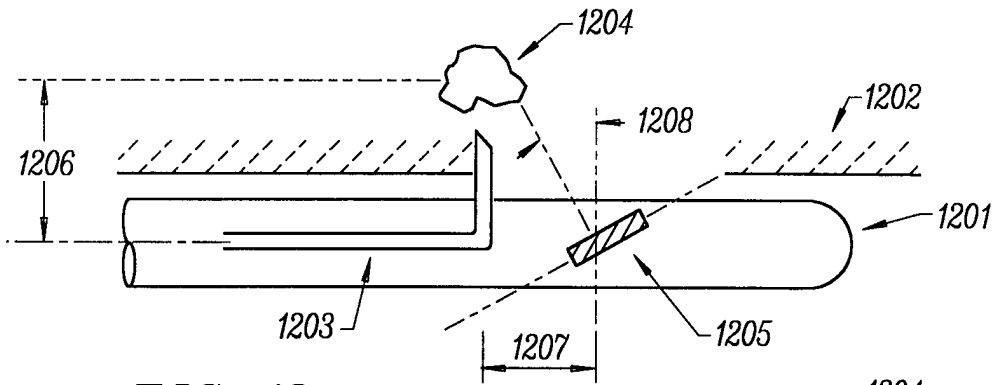

FIG. 12

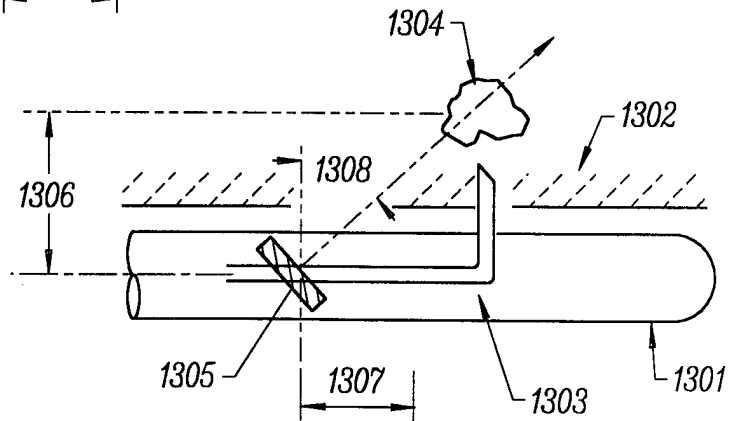

FIG. 13

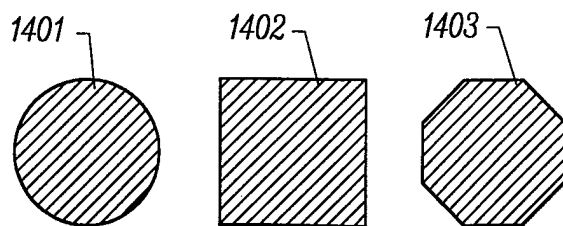

FIG. 14

6/12

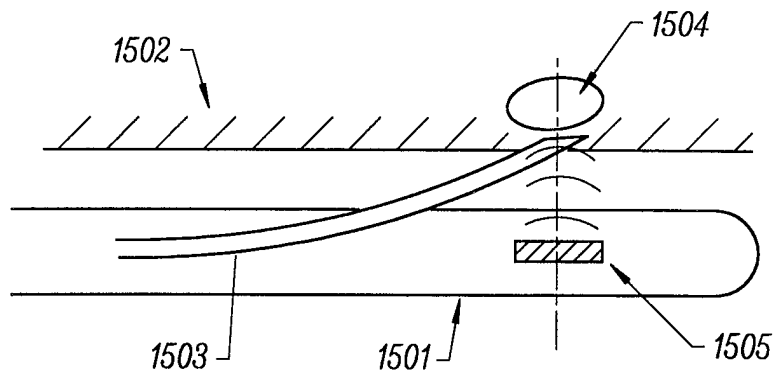

FIG. 15

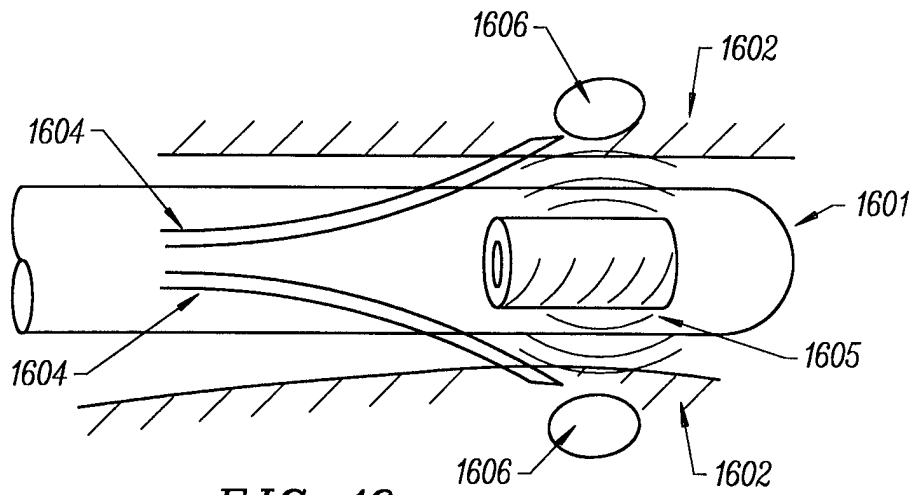

FIG. 16

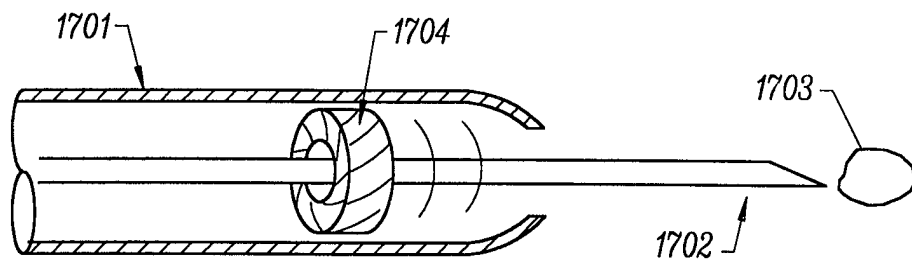

FIG. 17

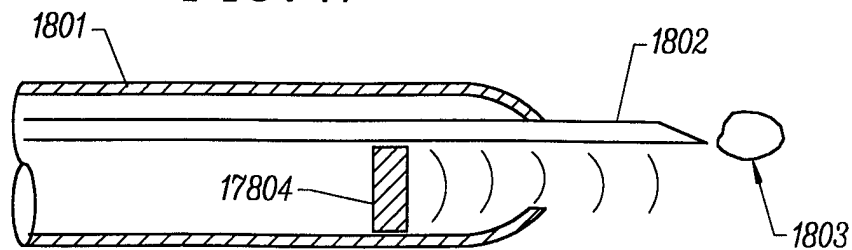

FIG. 18

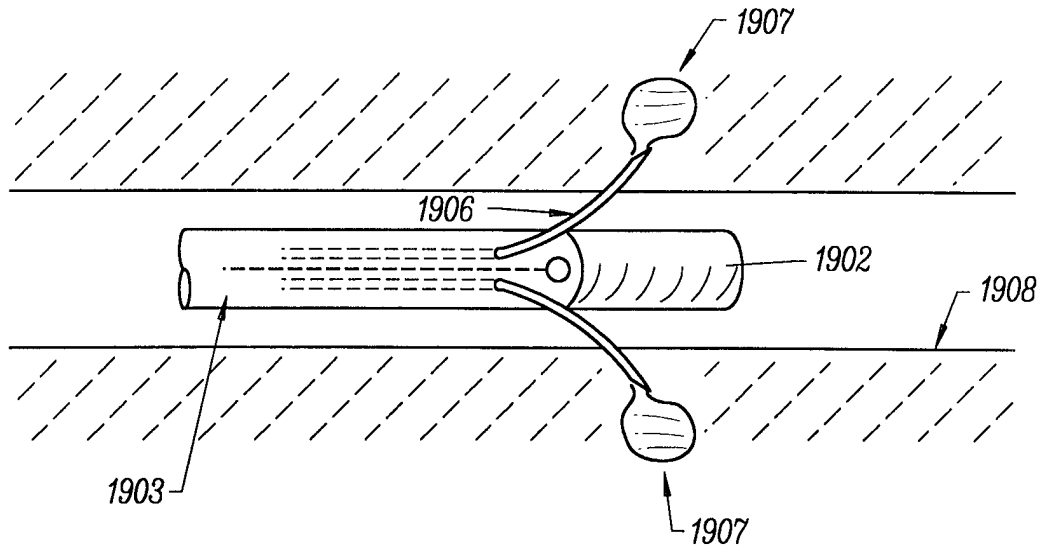

FIG. 19

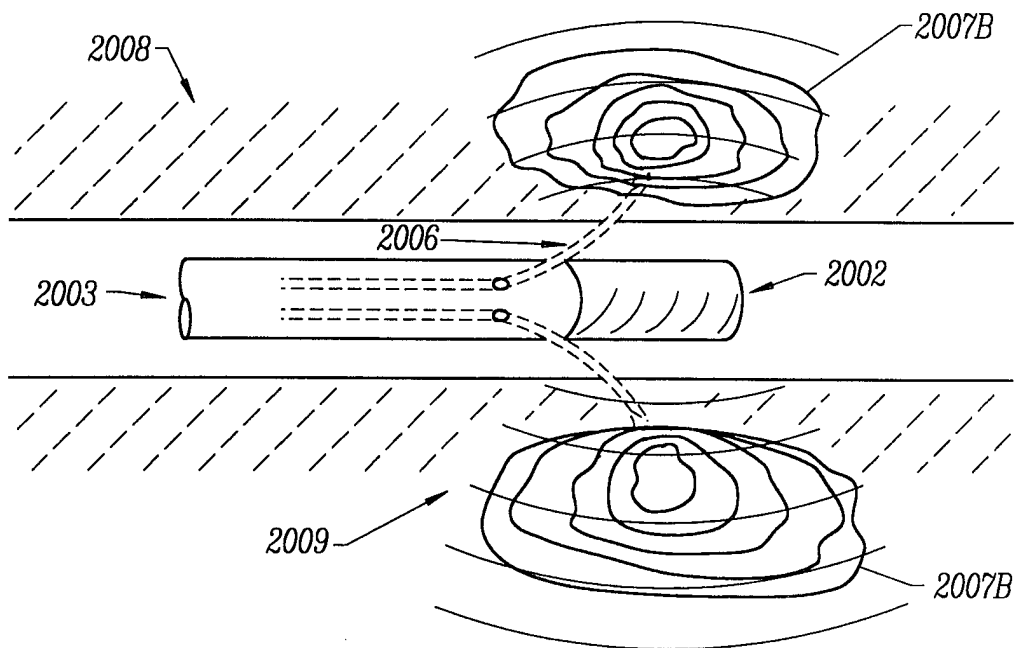

FIG. 20

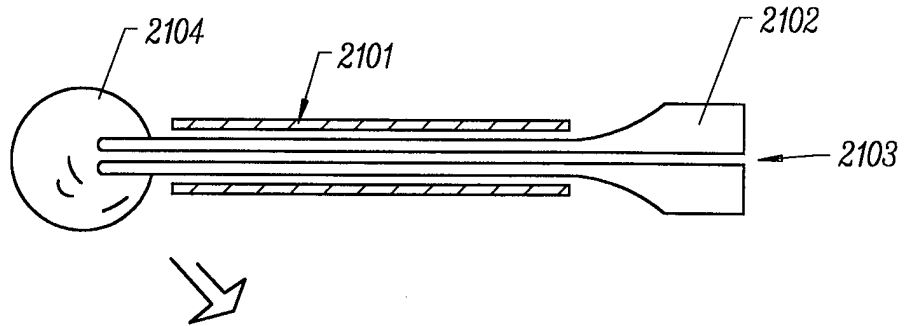

FIG. 21

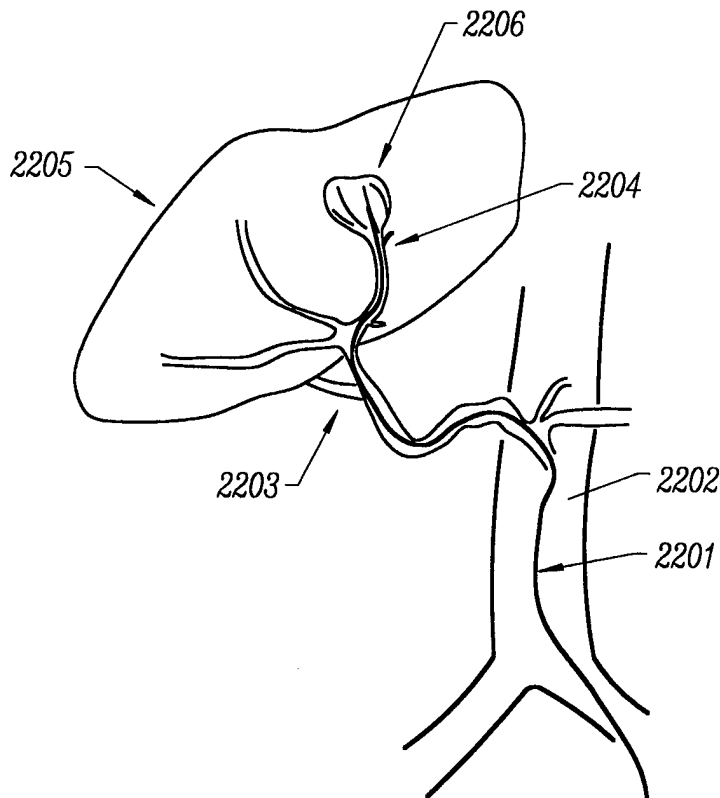

FIG. 22

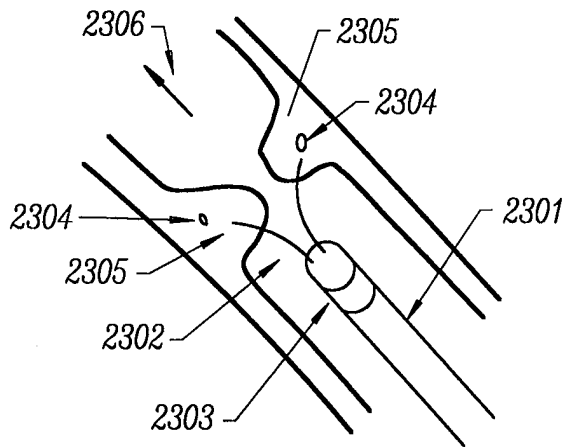

FIG. 23

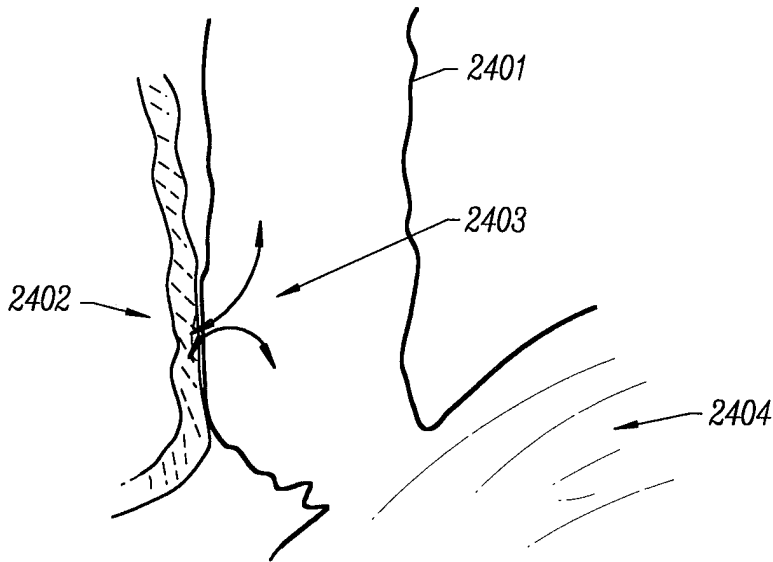

FIG. 24

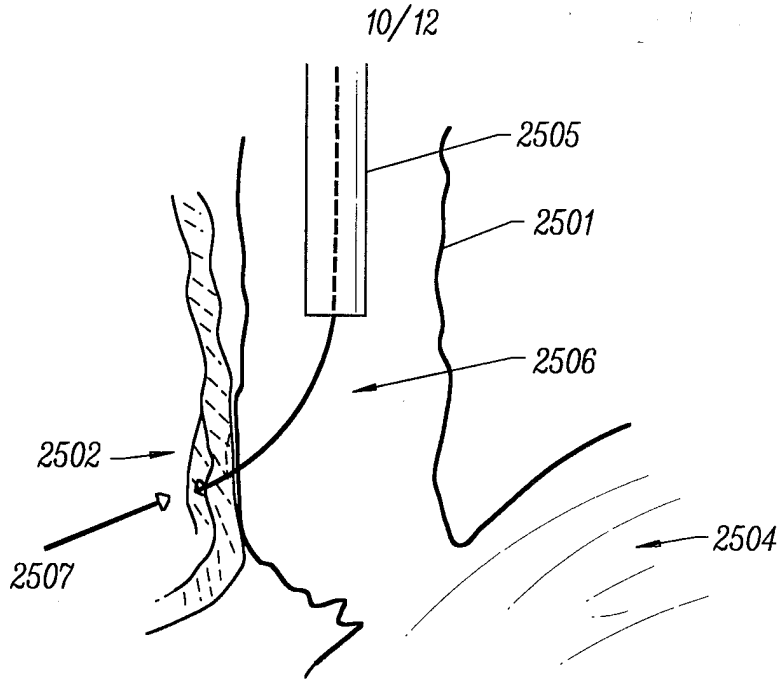

FIG. 25

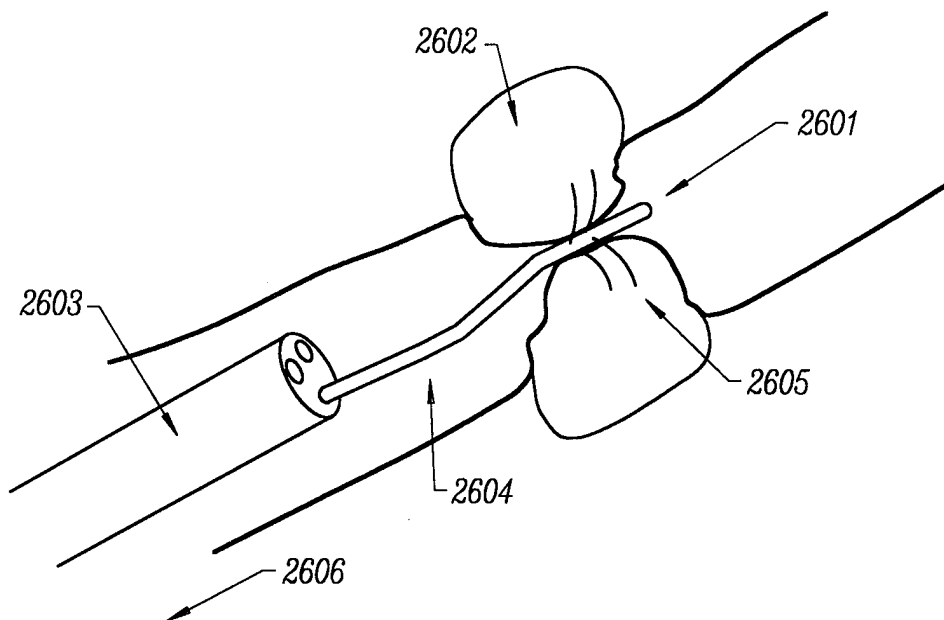

FIG. 26

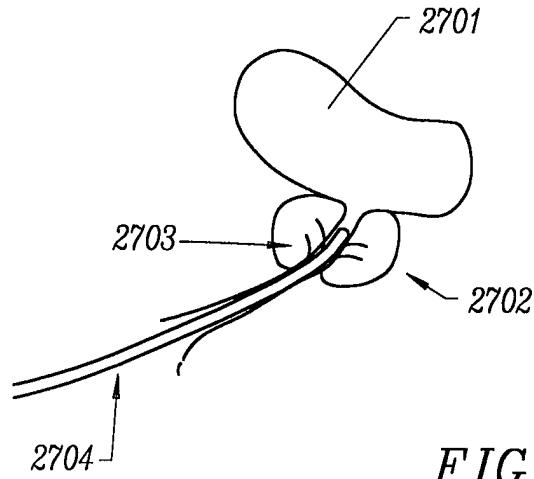

FIG. 27

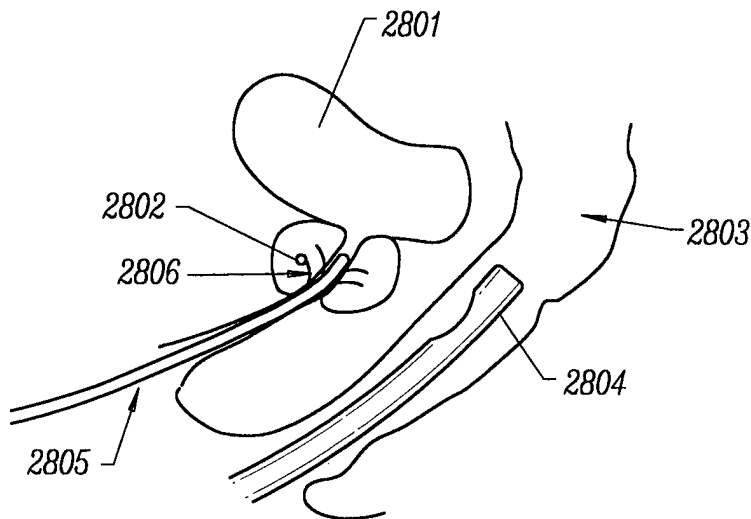

FIG. 28

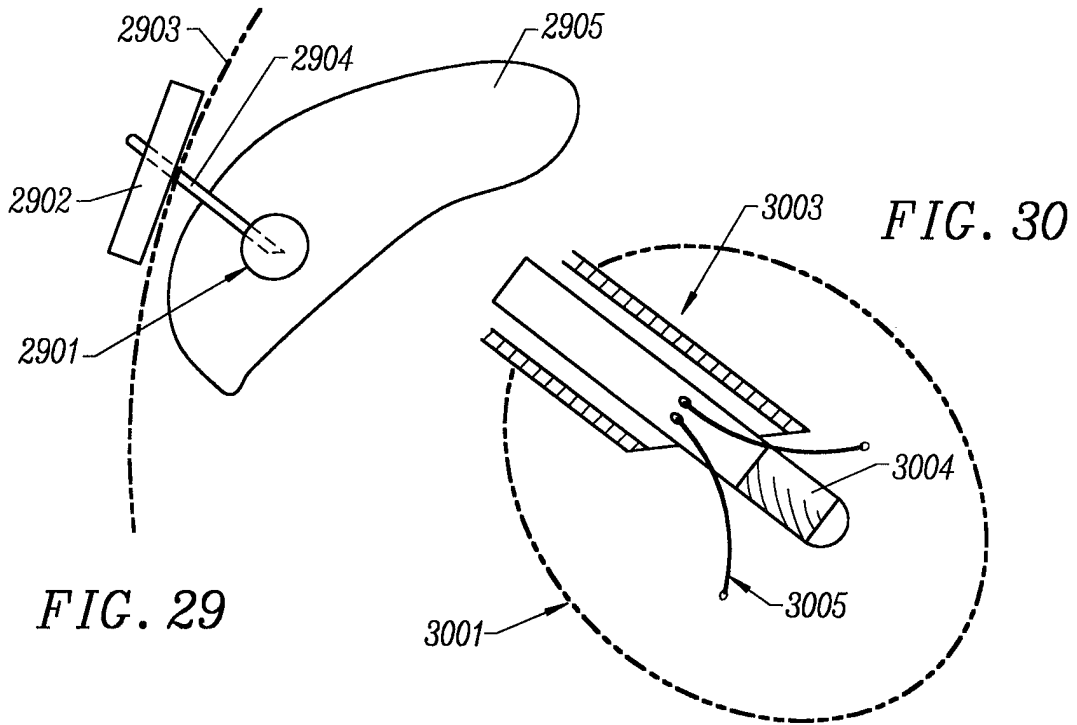

FIG. 29

FIG. 30

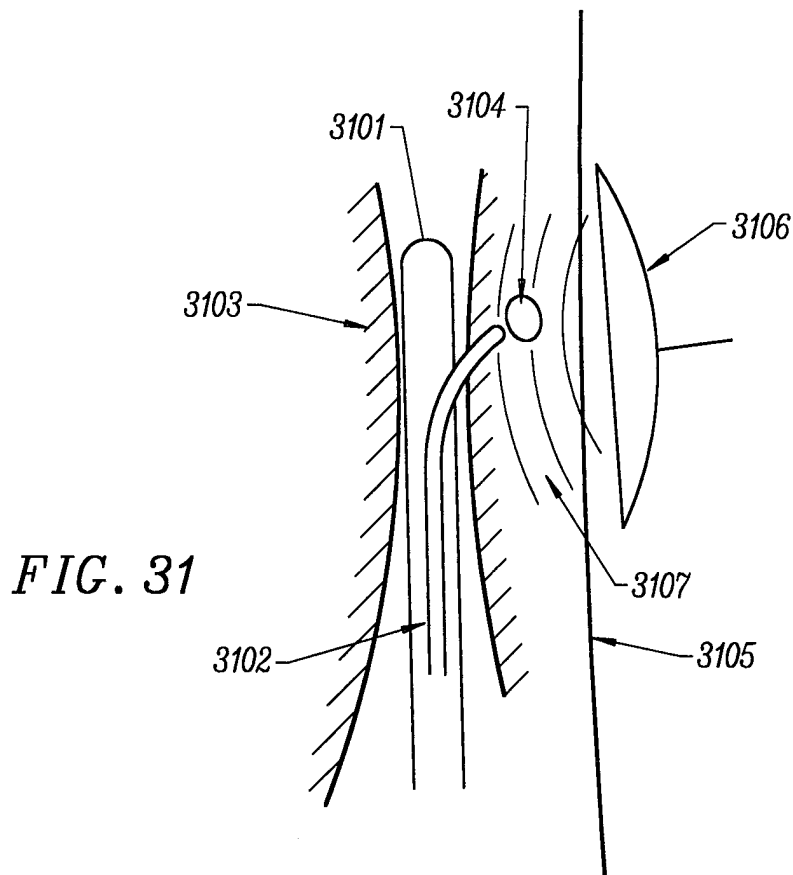

FIG. 31

INTERNATIONAL SEARCH REPORT

Internal Application No PCT/US 97/19993
--

A. CLASSIFICATION OF SUBJECT MATTER IPC 6 A61B17/22				
According to International Patent Classification (IPC) or to both national classification and IPC				
B. FIELDS SEARCHED Minimum documentation searched (classification system followed by classification symbols) IPC 6 A61M A61B				
Documentation searched other than minimum documentation to the extent that such documents are included in the fields searched				
Electronic data base consulted during the international search (name of data base and, where practical, search terms used)				
C. DOCUMENTS CONSIDERED TO BE RELEVANT				
Category °	Citation of document, with indication, where appropriate, of the relevant passages	Relevant to claim No.		
A	US 5 354 279 A (HOEFLING) 11 October 1994 see abstract see column 1, line 48 - column 2, line 40; figures 1,2,8-12 ---	1-34		
A	EP 0 629 382 A (VIDAMED INC.) 21 December 1994 see abstract see column 3, line 46 - column 4, line 47 see column 6, line 8 - line 44; figures 1-4,7 ---	1-34		
A	EP 0 529 675 A (ETHICON INC.) 3 March 1993 see abstract see column 2, line 38 - column 3, line 17; figure 1 -----	1,17		
<table style="width: 100%; border: none;"> <tr> <td style="width: 50%; border: none;"> <input type="checkbox"/> Further documents are listed in the continuation of box C. </td> <td style="width: 50%; border: none;"> <input checked="" type="checkbox"/> Patent family members are listed in annex. </td> </tr> </table>			<input type="checkbox"/> Further documents are listed in the continuation of box C.	<input checked="" type="checkbox"/> Patent family members are listed in annex.
<input type="checkbox"/> Further documents are listed in the continuation of box C.	<input checked="" type="checkbox"/> Patent family members are listed in annex.			
° Special categories of cited documents :				
A document defining the general state of the art which is not considered to be of particular relevance	*T* later document published after the international filing date or priority date and not in conflict with the application but cited to understand the principle or theory underlying the invention			
E earlier document but published on or after the international filing date	*X* document of particular relevance; the claimed invention cannot be considered novel or cannot be considered to involve an inventive step when the document is taken alone			
L document which may throw doubts on priority claim(s) or which is cited to establish the publication date of another citation or other special reason (as specified)	*Y* document of particular relevance; the claimed invention cannot be considered to involve an inventive step when the document is combined with one or more other such documents, such combination being obvious to a person skilled in the art.			
O document referring to an oral disclosure, use, exhibition or other means	*&* document member of the same patent family			
P document published prior to the international filing date but later than the priority date claimed				
Date of the actual completion of the international search <div style="text-align: center; font-size: 1.2em;">6 March 1998</div>	Date of mailing of the international search report <div style="text-align: center; font-size: 1.2em;">13.03.98</div>			
Name and mailing address of the ISA European Patent Office, P.B. 5818 Patentlaan 2 NL - 2280 HV Rijswijk Tel. (+31-70) 340-2040, Tx. 31 651 epo nl, Fax: (+31-70) 340-3016	Authorized officer <div style="text-align: center; font-size: 1.2em;">Michels, N</div>			

INTERNATIONAL SEARCH REPORT

International application No.
PCT/US 97/19993

Box I Observations where certain claims were found unsearchable (Continuation of item 1 of first sheet)

This International Search Report has not been established in respect of certain claims under Article 17(2)(a) for the following reasons:

1. Claims Nos.: 35-58
because they relate to subject matter not required to be searched by this Authority, namely:
Rule 39.1(iv) PCT - Method for treatment of the human or animal body by therapy
2. Claims Nos.:
because they relate to parts of the International Application that do not comply with the prescribed requirements to such an extent that no meaningful International Search can be carried out, specifically:
3. Claims Nos.:
because they are dependent claims and are not drafted in accordance with the second and third sentences of Rule 6.4(a).

Box II Observations where unity of invention is lacking (Continuation of item 2 of first sheet)

This International Searching Authority found multiple inventions in this international application, as follows:

1. As all required additional search fees were timely paid by the applicant, this International Search Report covers all searchable claims.
2. As all searchable claims could be searched without effort justifying an additional fee, this Authority did not invite payment of any additional fee.
3. As only some of the required additional search fees were timely paid by the applicant, this International Search Report covers only those claims for which fees were paid, specifically claims Nos.:
4. No required additional search fees were timely paid by the applicant. Consequently, this International Search Report is restricted to the invention first mentioned in the claims; it is covered by claims Nos.:

Remark on Protest

- The additional search fees were accompanied by the applicant's protest.
- No protest accompanied the payment of additional search fees.

INTERNATIONAL SEARCH REPORT

Information on patent family members

International Application No

PCT/US 97/19993

Patent document cited in search report	Publication date	Patent family member(s)	Publication date
US 5354279 A	11-10-94	DE 4235506 A	28-04-94
		AT 134137 T	15-02-96
		AU 5369694 A	09-05-94
		CA 2146989 A	28-04-94
		CZ 9500973 A	15-11-95
		DE 59301654 D	28-03-96
		WO 9408653 A	28-04-94
		EP 0689467 A	03-01-96
		ES 2083876 T	16-04-96
		FI 951879 A	20-04-95
		HK 213396 A	06-12-96
		HU 72681 A	28-05-96
		JP 8504613 T	21-05-96
		NO 951490 A	20-04-95
		PL 308463 A	24-07-95
SK 50995 A	09-08-95		

EP 0629382 A	21-12-94	US 5370675 A	06-12-94
		AT 132046 T	15-01-96
		AU 671405 B	22-08-96
		AU 2047595 A	10-08-95
		AU 657235 B	02-03-95
		AU 4999893 A	15-03-94
		CA 2121032 A	03-03-94
		DE 4305663 A	17-02-94
		DE 69301143 D	08-02-96
		EP 0611314 A	24-08-94
		ES 2084510 T	01-05-96
		FI 950584 A	04-04-95
		FR 2694700 A	18-02-94
		GB 2269538 A,B	16-02-94
		IL 104647 A	31-12-95
		JP 7503645 T	20-04-95
		MX 9304905 A	29-04-94
		NZ 255687 A	20-12-96
		US 5385544 A	31-01-95
		US 5421819 A	06-06-95
US 5435805 A	25-07-95		
WO 9404220 A	03-03-94		
US 5409453 A	25-04-95		

INTERNATIONAL SEARCH REPORT

Information on patent family members

International Application No

PCT/US 97/19993

Patent document cited in search report	Publication date	Patent family member(s)	Publication date
EP 0629382 A		US 5470308 A	28-11-95
		US 5366490 A	22-11-94
		US 5556377 A	17-09-96
		US 5542915 A	06-08-96
		US 5470309 A	28-11-95
		US 5554110 A	10-09-96
		US 5549644 A	27-08-96
		US 5484400 A	16-01-96
		US 5630794 A	20-05-97
		US 5514131 A	07-05-96
		US 5672153 A	30-09-97
		US 5531676 A	02-07-96
		US 5536240 A	16-07-96
		US 5542916 A	06-08-96
		US 5599294 A	04-02-97
		US 5540655 A	30-07-96
		US 5667488 A	16-09-97
		US 5531677 A	02-07-96
		US 5582589 A	10-12-96
		US 5591125 A	07-01-97
		US 5599295 A	04-02-97
		US 5607389 A	04-03-97
		US 5681277 A	28-10-97
	US 5718702 A	17-02-98	
	AU 685086 B	15-01-98	
	AU 6133194 A	29-08-94	

EP 0529675 A	03-03-93	US 5219358 A	15-06-93
		AU 667673 B	04-04-96
		AU 2126792 A	22-04-93
		CA 2077063 A	01-03-93
		DE 69208182 D	21-03-96
		DE 69208182 T	05-09-96
		EG 19806 A	29-02-96
		ES 2083039 T	01-04-96
		GR 92100362 A	07-06-93
		IL 102861 A	14-05-96
		JP 5200036 A	10-08-93
		TR 26729 A	15-05-95
