

V. ROHDE.
 DISPLAY MACHINE.
 APPLICATION FILED SEPT. 19, 1910.

997,637.

Patented July 11, 1911.

3 SHEETS-SHEET 1.

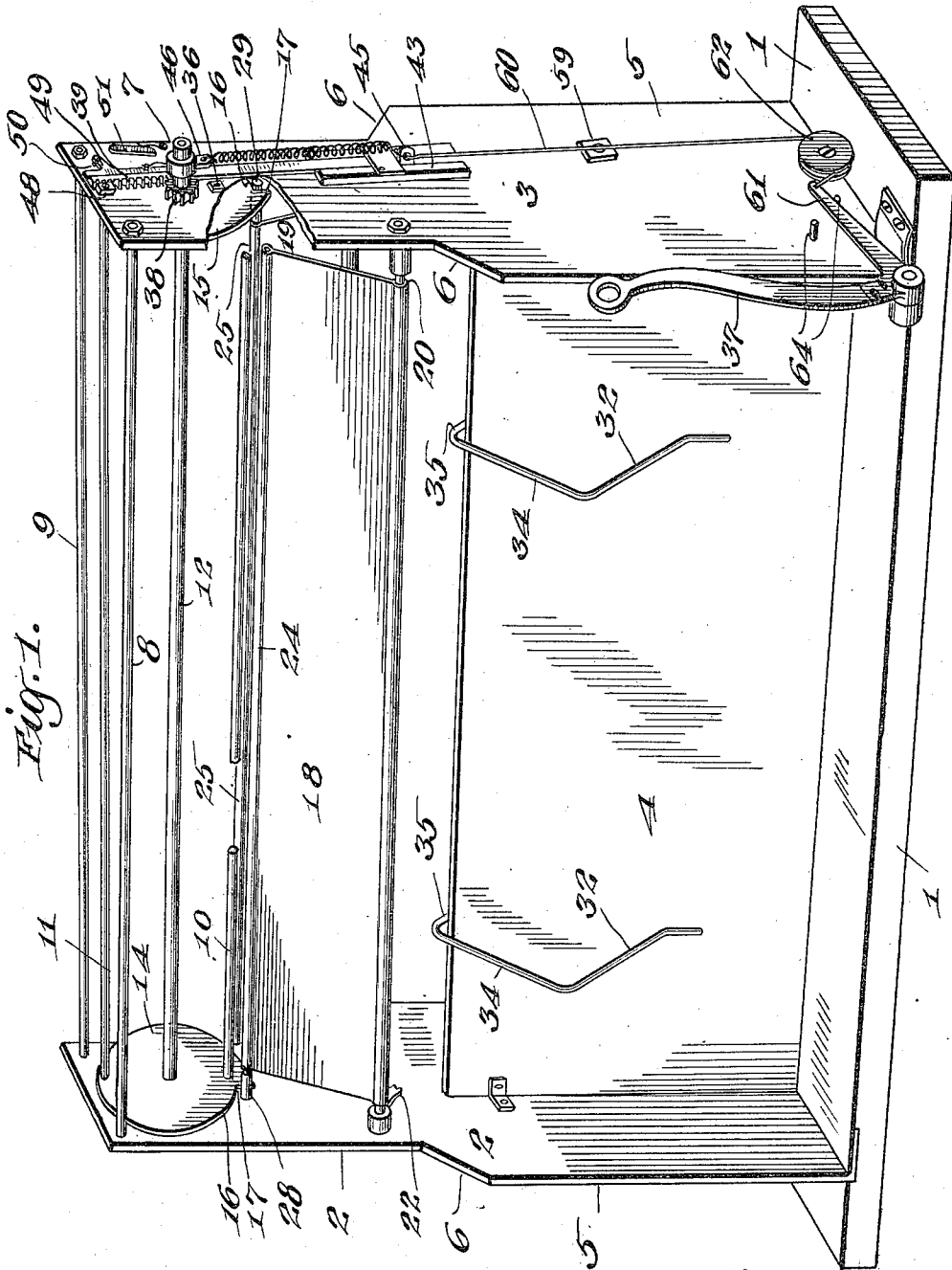

Fig. 1. 9

WITNESSES
H. Leichter
W. Allen

INVENTOR
 Victor Rohde
 BY
Ronald Day
 ATTORNEY

997,637.

V. ROHDE.
DISPLAY MACHINE.
APPLICATION FILED SEPT. 19, 1910.

Patented July 11, 1911.

3 SHEETS—SHEET 2.

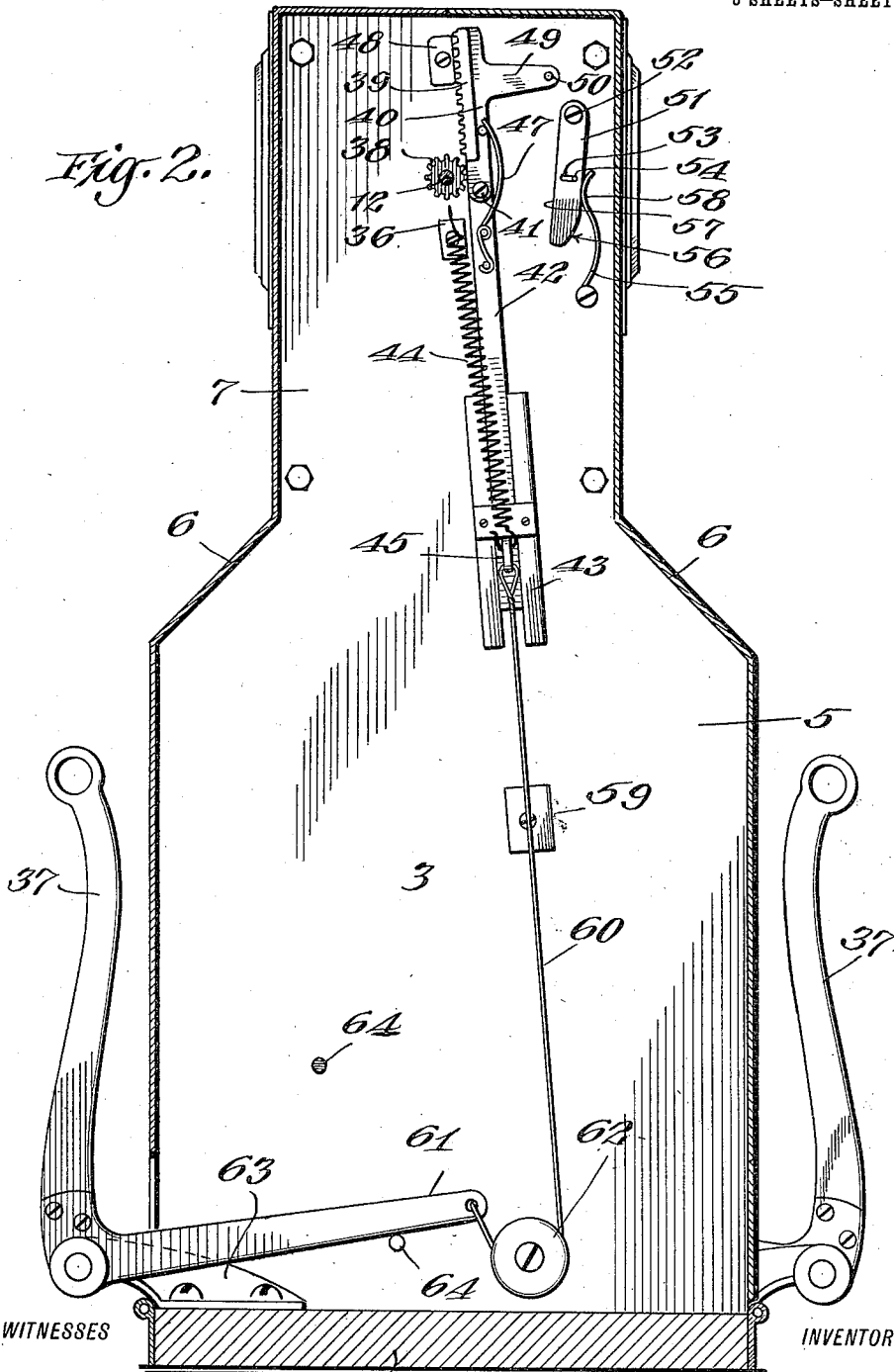

WITNESSES
H. Crocker
W. Allen

1

INVENTOR
Victor Rohde
BY
Howard Day,
ATTORNEY

V. ROHDE,
DISPLAY MACHINE.

APPLICATION FILED SEPT. 19, 1910.

Patented July 11, 1911.

997,637.

3 SHEETS-SHEET 3.

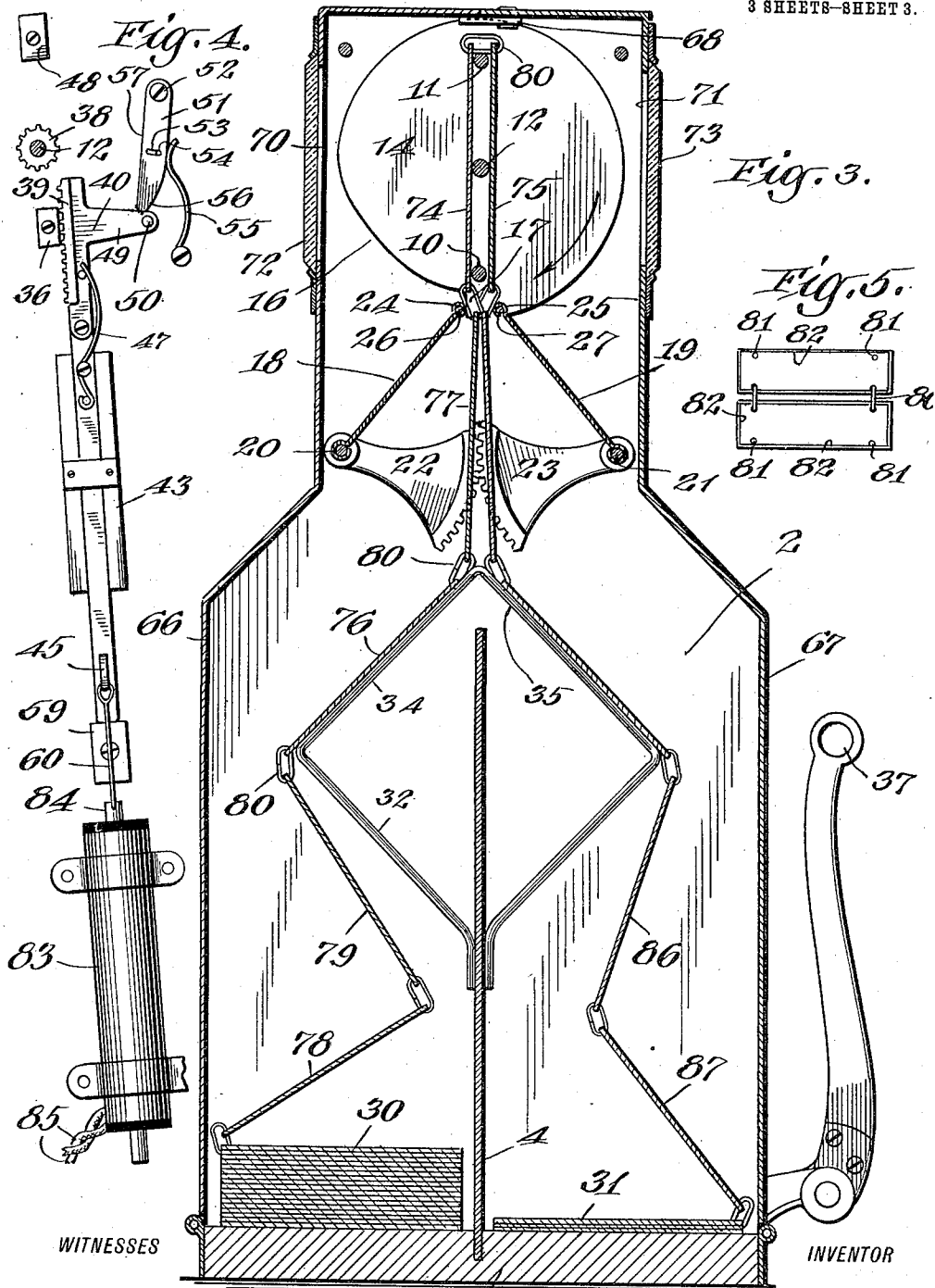

WITNESSES
H. C. Cochran
W. J. Allen

INVENTOR
Victor Rohde
BY
R. D. Day
ATTORNEY

UNITED STATES PATENT OFFICE.

VICTOR ROHDE, OF NEW YORK, N. Y.

DISPLAY-MACHINE.

997,637.

Specification of Letters Patent. Patented July 11, 1911.

Application filed September 19, 1910. Serial No. 582,715.

To all whom it may concern:

Be it known that I, VICTOR ROHDE, a subject of the Emperor of Germany, and a resident of the borough of Manhattan, county, city, and State of New York, have invented certain new and useful Improvements in Display-Machines, set forth in the following specification.

This invention relates to display machines and its purpose is to accomplish, in an improved manner, the automatic display of the surface of a chain or interlinked sequence of cards so that the display surface of each card is displayed in a predetermined sequence or progression.

A further object of the invention is to provide for the simultaneous display toward opposite directions of the display surface of each of a pair of interlinked cards in such a manner that a plurality of interlinked pairs of cards may be displayed in a predetermined sequence.

The invention is particularly adapted for use as a station indicator for railway cars, although it is also well adapted for the display of advertising matter.

A further object of the invention is to provide for the quick and convenient change of the subject matter to be displayed by the apparatus. It is not only an object to provide for the quick and convenient substitution of an entirely new chain of display cards but to provide for the equally ready removal of any one or more of a plurality of the display cards and substitution of a new card or cards.

A further object of the invention is to provide for as large a capacity for display in as small a space as possible, while still further objects of the invention are to improve in general the mechanism for apparatus of the type described.

The above and further objects of the invention will be pointed out in the following claims, which should be considered in connection with the following descriptive specification, which refers to an illustrative embodiment of the invention shown in the accompanying drawings, which form a part of this application, in which like characters designate corresponding parts, and in which,—

Figure 1 is a perspective view of the apparatus with its outer casing removed and with parts broken away to show obscured parts; Fig. 2 is a cross-section through the right hand end of the complete apparatus

looking from right to left in Fig. 1 and taken approximately through the plane of the operating lever; Fig. 3 is a central cross-section through the complete apparatus looking from right to left; Fig. 4 is a detail view of the operating mechanism showing a modification of the application of power; and Fig. 5 is a plan view of a chain of a plurality of display cards.

For a ready understanding of this apparatus it is suggested that it be borne in mind that the entire apparatus is substantially symmetrical relatively to two planes one cutting the apparatus in central cross-section and one cutting the apparatus in central longitudinal-section. This feature of construction greatly adds to the simplicity of manufacture.

A base-board 1 may serve as the mounting support to which end frames 2 and 3 are secured in a suitable manner to extend vertically therefrom. The central longitudinal partition 4 is likewise suitably mounted on the base-board 1 and may be stayed to the end frames 2 and 3 in a suitable manner. Each end frame comprises a substantially rectangular bottom portion 5 terminating at the top in symmetrically inclined hip portions 6 and then it extends into an upper central extension 7 of rectangular form. Stay rods 8 and 9 extend longitudinally across from the top of one end frame to the other being secured at their ends in the respective end frames to complete the framework for the apparatus.

The card-shifter comprises the cross-rods 10 and 11 suitably framed on opposite sides of and equidistant from a horizontal axis. These framed rods are so mounted as to be rotatable about this horizontal axis which corresponds with that of the spindle 12.

In the embodiment illustrated the rods 10 and 11 are fixed at their respective ends to mutilated disks 14 and 15 which in turn are mounted upon the spindle 12 which is centrally journaled in the upper portions of the frame pieces 2 and 3 and extends therethrough. The disks 14 and 15 are precisely similar but the cam face 16 and the operating shoulder 17 of cam-disk 14 face oppositely to the similar parts of disks 15, for a purpose presently to be explained.

The frame comprising the cross-rods 10 and 11 is shown in its display position, in which position it is held through the medium of the shoulders 17. A pair of tilting

shutters 18 and 19 cooperate in this holding of the shifting frame. Shutter 18 is fixed at its lower edge to spindle 20, suitably journaled at its ends in the frames 2 and 3, while the shutter 19 is also fixed along its lower edge to a spindle 21 likewise journaled at its ends in the end frames 2 and 3. A segmental gear 22 is fixed to one end of spindle 20 and extends backward substantially horizontally to intermesh with the similar segmental gear 23 similarly fixed to spindle 21 so that the tilting movement of the shutters 18 and 19 is synchronized and the weight of the segmental gears 22 and 23 tends to tilt these shutters inwardly as indicated.

The shutters 18 and 19 are shown formed of sheet metal and have beads 24 and 25 along their upper edges inclosing stiffening rods 26 and 27. The stiffening rod 26 extends to the left as shown in Fig. 1 to form a journal for the roller or cam follower 28, while the rod 27 is extended to the right to carry the similar follower 29.

Guiding means for folding the display cards in piles 30 and 31 upon the base-board 1 are shown in the form of a plurality of bent wire frames 32 of wire bent into the substantially square outline shown and suitably secured to the partition 4, although it is understood that essentially these frames comprise merely suitable downward and outward deflecting members, such as the parts 34 and 35.

Operating mechanism for rotating the card-shifter in the direction of the arrow shown in Fig. 1 is mounted on the outer face of end frame 3 under control of the corresponding actuating bell-crank lever 37, while a duplicate of this operating mechanism is mounted in a precisely similar manner upon the opposite end frame 2 under control of its actuating bell-crank lever 37. As is obvious, the operating mechanism mounted on end frame 2 operates to rotate the card shifting frame in the opposite direction.

The projecting end of the spindle 12 has fixed to it the spur gear 38, with which cooperates the rack 39, which is of a suitable length and has a suitable stroke to effect one complete rotation of the spindle 12 and the card shifting frame, but is normally out of mesh with gear 38. The rack 39 is formed on member 40 which is pivoted at its lower end by the pin 41 to the upper end of the slide rod 42, working in the guides 43 and normally drawn upward by the tension spring 44, which is attached at its lower end to the eye 45, formed on the rod 42, and at its upper end to the slip sleeve 46 loosely journaled on the projecting end of spindle 12. The rack member 40 is normally pressed by spring 47 toward the spur gear 12 and when the parts are in normal position

against the stop 48 and when at bottom stroke against stop 36.

The rack member 40 is provided with the laterally extending arm 49 which is spaced apart from the upper portion 7 of the end frame and carries at its end a pin 50 projecting inwardly toward but not to the said part 7 of the end frame.

A rocker cam 51 is pivoted at its upper end by pin 52 to the upper part 7 of the end frame and has a limited throw defined by the slot 53 and pin 54 fixed to the portion 7 of the end frame. The spring 55 normally presses the rocker cam 51 toward the spur gear 12 so that its cam nose 56 is slightly nearer to the rod 42 than is the pin 50 when the parts are normally positioned, as shown in Fig. 2. The outward throw of the rocker cam 51 against the spring 55 and until stopped by the pin 54 is just sufficient so that the face 57 of the rocker cam 51 will then be parallel to the stroke of rod 42. As a detail of construction it may be well to mention that the extent of the bearing end 58 of spring 55 at right angles to the end frame portion 7 is less than the similar extent or thickness of rocker cam 51 so that the spring 58 is unengageable by the pin 50 which does not extend to the face of end frame portion 7 but stops short thereof, although this is not a necessity.

A stop 59 secured to the end frame limits the downward throw of rod 42.

The application of power to the slide rod 42 may be effected by the flexible link 60 which, in Figs. 1, 2 and 3, is shown actuated by bell crank lever 37, the inner arm 61 of which is connected to the flexible link 60 after it passes over the pulley 62. The bell crank lever is pivoted at its elbow to a suitable frame 63 attached to the mounting board 1. The throw of the bell crank lever may be limited by the stops 64.

The entire mechanism thus far described may be incased in a suitable casing. The casing illustrated comprises two symmetrical parts 66 and 67 hinged along their bottom edges to the mounting board 1 and conforming to the contour of the end frames against which these two parts may be locked by the catch 68. The two parts of the casing are respectively provided with rectangular side openings 70 and 71 which may be covered by the framed transparent panes 72 and 73 as shown. These side openings should correspond in size and extent substantially with the framed opening between the rods 10 and 11, being slightly less in extent of opening than the surface of the display cards, two of which 74 and 75 are shown in display position in Fig. 3.

For the direction of movement indicated in Fig. 3 the next pair of cards to be displayed is that denoted by 76 and 77; while the next pair is denoted by 78, 79. Each

card comprises a rectangular piece of suitable material, such as card board or sheet metal and is hinge linked to each of its neighbors in a suitable manner. Readily disengageable links 80 engaging in eyelets 81 are shown used for this purpose. If it is found desirable to construct these cards of fragile material, it may be found expedient to bind their edges with reinforcing strips 82, as shown in Fig. 5.

Fig. 4 illustrates the operating mechanism for the card shifter with its parts in their various positions assumed immediately after a rotation of the card shifter has been completed. It also shows a modification of the application of power. In this figure a solenoid 83 is employed in place of the lever 37, its core 84 being connected directly with the flexible link 60 while its terminals 85 are free to be connected into any suitable electric circuit, the opening and closing of which may be controlled in any manner, automatic or otherwise, now known to the art. As a matter of fact solenoid 83 is shown merely as one illustration of an electric motor.

Operation: To cause the shifting of the chain of display cards so that the cards 76 and 77 shall be shifted into positions opposite the windows 72 and 73 respectively, the bell crank lever or other suitable source of power corresponding to the end partition 3 is actuated so as to draw down the slide rod 42 against the tension of spring 44. The rack 39 is caused to engage with the spur gear 38, while a substantially simultaneous engagement of the pin 50 is effected with the guiding face 57 of rocker cam 51, which holds the rack 39 in mesh with the gear 38 to cause one complete rotation of the gear 38. The stroke of the slide bar 42 may be in excess of the amount necessary to cause one rotation of the gear 38 if the rack 39 were rigidly fixed thereto. This is a fact because the duration of engagement of the rack 39 with spur gear 38 is limited by the length of the face 57 on rocker cam 51, the spring 47 being insufficient to hold the rack 39 operatively in mesh with the gear 38. As soon as the pin 50 passes the nose 56 of rocker cam 51 the spring 55 causes the rocker cam 51 to fly back into the position shown in Fig. 4 so that, upon the return stroke of the slide rod 42 and rack member 40 the pin 50 engages the opposite inclined face of the nose 56 and rides over it to disengage the rack 39 from the spur gear 38. A uni-directional drive for the gear 38 and its attached parts is thereby provided. After the pin 50 rides over the top end of rocker cam 51 the spring 47 returns it into its normal position shown in Fig. 2 ready to reengage the spur gear 38 upon successive operations. The consequent rotation of the card shifting

mechanism within the machine is in the direction of the arrow shown in Fig. 3. The shoulder 17 of disk 14 tilts out the shutter 18 by its engagement with the follower 28. Through the medium of the shaft 20 the shutter 18 elevates the segmental gear 22 which in turn transmits an upward movement to the segmental gear 23 to swing out its corresponding shutter 19. The upper edges 24 and 25 of these shutters 18 and 19, therefore, move apart. At the same time the lower edge of card 74 is carried around by the frame rod 10 with its links 80 in contact with the edge 24, the follower 28 riding out along the shoulder 16 until it rides over the shoulder onto the circular periphery of the disk 14 where it is temporarily held by a sort of toggle action to permit the free upward passage of the succeeding cards 77 and 76. At the same time the segmental gears 22 and 23 hold out the edge 25 of shutter 19 to permit the downward feeding of the cards 75 and 74. Adjacent cards of the chain hinge over the rods 10 and 11 at their edges where they are connected by their links 80. After one complete rotation of the spindle 12 and consequently of the framed rods 10 and 11, the rod 11 has engaged the links 80 connecting cards 76 and 77 to suspend the cards 76 and 77 in positions precisely the same as those illustrated for cards 74 and 75; the cards 78 and 79 have been drawn up into the position now occupied by the cards 76 and 77; and the cards 86 and 87 have been folded down onto the pile 31.

The last 90° of the periphery of disk 14 is the cam face 16 which has permitted the follower and the shutter 18 to fall back into normal position, as shown, follower 28 reengaging shoulder 17. At the same time the shutter 19 falls back into normal position and its follower 29 engages the shoulder 17 of the opposite disk 15. The weight of the segmental gears 22 and 23 tends to hold the followers 28 and 29 firmly in contact with the respective shoulders 17 substantially to lock the card shifting frame in display position. At the same time the upper edges 24 and 25 of the shutter frames engage the links 80 at the lower edges of the cards 76 and 77 (formerly 74 and 75) to hold them vertical before the opposite windows. This operation may be repeated successively to display successive pairs of interlinked display cards forming the complete chain which is contained in the pile 30. In case the machine is employed as a station indicator for railway trains the display surface of each card of a pair would bear the designation of a station, successive pairs indicating successive stations throughout a certain route. Upon the return trip the reverse order of movement is obtained by successively actuating the operating

mechanism for rotating the card shifter and which is provided in conjunction with the end plate 2. The operation is precisely the same as that described except that cards are fed from the pile 31 onto the pile 30 instead of vice versa and that the shoulder 16 of disk 15 cooperating with the follower 29 is serviceable in opening the shutters 18 and 19, instead of shoulder 16 of disk 14.

Mechanically the shutters 18 and 19 comprise, of necessity, no more than their upper edges such as 24 and 25 and the attached followers 28 and 29 with connecting means as a lever attaching these parts to the journaled spindles 20 and 21 respectively. In the actual embodiment shown these shutters are virtually shutters inasmuch as they obscure from view all cards except those intended to be displayed.

It is to be understood that the various parts of this machine may be constructed of any material suitable for the purpose and that the embodiment described has been shown merely for purposes of illustration.

What is claimed and what is desired to be secured by United States Letters Patent is:—

1. In combination in a display machine, an elevated shifting frame horizontally mounted to rotate in opposite directions on a horizontal axis; a chain of interlinked display cards looped over said shifting frame, each said pair comprising two like cards having their top edges interlinked so that their respective display legends are relatively reversed; externally operable means mechanically engageable with said shifting frame and operative to impart such a rotation to said shifting frame as will completely shift one pair of display cards out of display position, and another pair of display cards both into display position; and laterally and downwardly extending guides arranged symmetrically beneath the axis of rotation of said shifting frame and operative to fold the display cards into piles one on one side and one on the other side according to the direction of the rotation of said shifting frame.

2. In a display machine, a rotatable shifting-frame having a pair of parallel card engaging members spaced apart a distance to approximate the corresponding dimension of a display card of an interlinked chain of display cards to be shifted by said frame; a shutter frame mounted to swing against a display card to hold it in display position; and means on said shifting-frame operative to swing said frame clear of the

chain of display cards upon the operation of said shifting-frame to shift said chain.

3. In a display machine, a shifting frame mounted to rotate upon a horizontal axis and comprising two parallel rods equidistant from said axis; a pair of inclined shutters beneath and on opposite sides of said frame; means tending to hold the upper edges of said shutters closed together; and means for opening said shutters upon the rotation of said shifting frame to permit the free passage therebetween of the chain of display cards to be shifted, said means being constructed to release said shutters upon the complete operation of said shifting frame.

4. In a display machine, a shifting-frame mounted to rotate on a horizontal axis; a casing for the machine having a pair of display openings located on opposite sides of said shifting frame; a chain of interlinked display cards looped over said frame, the cards of said chain being arranged oppositely in pairs, one for display through one opening, the other for display through the opposite opening; and means for operating said shifting-frame to shift a pair of cards at a time and means adapted to prevent observance of cards other than those intentionally displayed and normally to hold said chain of cards in display position.

5. In a display machine, a shifting frame mounted to rotate on a horizontal axis; a casing for the machine having a pair of display openings located on opposite sides of said shifting frame; a chain of interlinked display cards looped over said frame, the cards of said chain being arranged oppositely in pairs one for display through one opening and the other for display through the opposite opening; a pair of shutter frames mounted to swing against oppositely disposed display cards to hold the chain in display position; a pair of co-acting members secured respectively to each of said shutter frames for transmitting motion from one to the other thereof; means for rotating said shifting frame in either direction and means formed and adapted, upon either movement of said shifting frame, to swing said shutter frames clear of the chain of display cards.

In witness whereof, I have signed my name to this specification, in the presence of two subscribing witnesses.

VICTOR ROHDE.

Witnesses:

C. E. HANSELMANN,
I. ALTMAN.