

June 11, 1968

G. R. BOSCHÉ

3,387,828

MIXER FOR PARTICULATE MATERIAL

Filed March 22, 1967

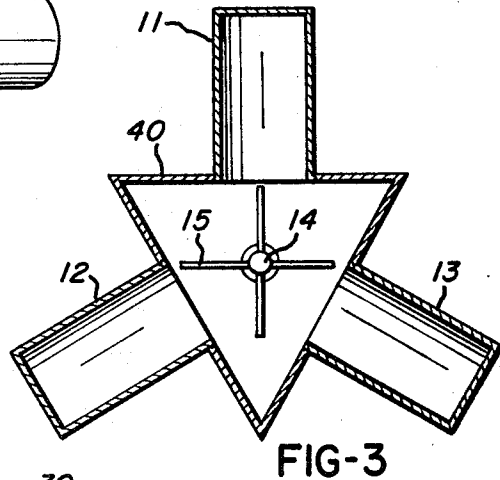
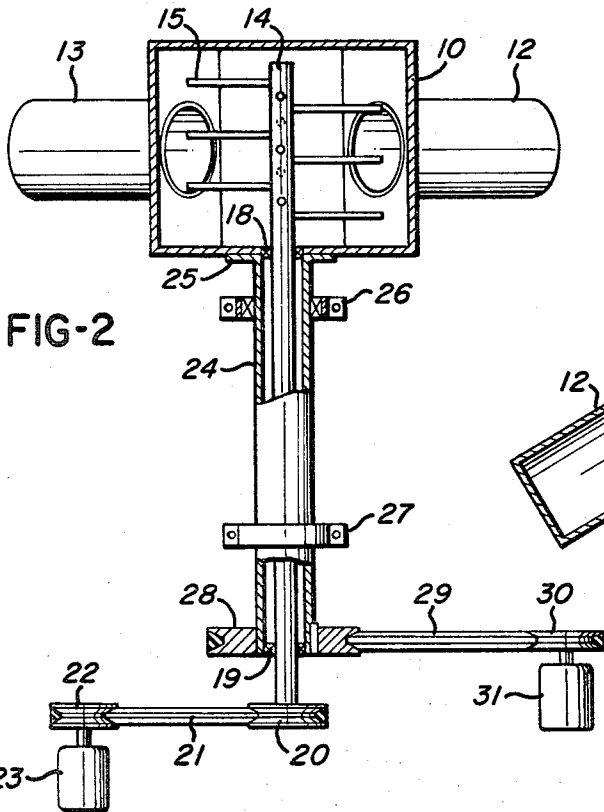
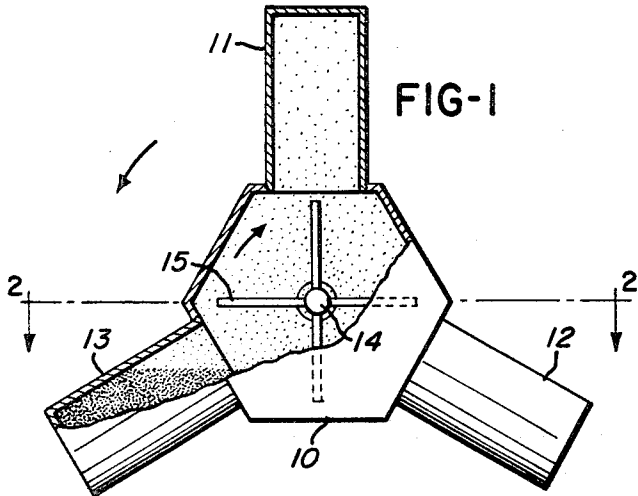

INVENTOR
GENE R. BOSCHÉ

BY

Reuben Wolk
ATTORNEY

1

2

3,387,828

MIXER FOR PARTICULATE MATERIAL

Gene R. Bosché, Kalamazoo, Mich., assignor to Dayco Corporation, Dayton, Ohio, a corporation of Delaware
 Filed Mar. 22, 1967, Ser. No. 625,205
 2 Claims. (Cl. 259—85)

ABSTRACT OF THE DISCLOSURE

A mixer for particulate material including a mixing chamber rotating about a horizontal axis, with removable material containers mounted on the chamber at right angles to the direction of rotation. The containers reach successive vertical positions above the chamber with an opening downward to drop their materials and intermix them in the chamber. A shaft with mixing members extends into the chamber and rotates to further promote mixing.

The present invention relates to a mixer for particulate material which provides for mixing materials that are dissimilar in composition or size. In industry and in the laboratory there are many instances where it is necessary to intermix particles of different sizes or materials together before further processing. This may be true in the manufacture of foods, rubber, chemicals, or plastics, or in a host of other fields. While various types of mixers have been used in the past, some are not fully satisfactory because they do not provide a thorough admixture of the different materials, or require an excessively long time to achieve a proper admixture. The present invention, however, accomplishes the thorough mixing in a comparatively short length of time by providing a rotating chamber having at least three containers mounted therein, each of these containers having different particulate material contained therein or all materials being placed in one container. The rotation of the chamber and containers permits that material which is in the upper position to drop down into the chamber and become distributed between the two other containers. As rotation continues, a different container is uppermost and it in turn drops its contents into the other two containers. This process is continued until the distribution of the material in each container into the other two has created the necessary admixture. Enhancing this operation is the use of mixing rods which rotate in an opposite direction to that of the mixing chamber, the rods helping to drive the particles evenly into the lower containers.

The invention is more fully described in the drawings, in which:

FIGURE 1 is an end elevational view of the novel device, in partial cross section.

FIGURE 2 is a view in partial section taken along line 2—2 of FIGURE 1.

FIGURE 3 is a view similar to FIGURE 1 illustrating a modified form of the invention.

As shown in FIGURES 1 and 2 the novel device consists of a hollow mixing chamber 10 which has a hexagonal cross section. The chamber may be made of metal, plastic, or other suitable material. Mounted equidistantly around the periphery of the chamber are containers 11, 12 and 13, which may be mounted as shown by threading them directly into the wall of the chamber, by bolting them on by means of flanges, or by other convenient and conventional mounting means. The mixing chamber 10 is mounted on a hollow shaft 24, securing it to the flange by welding, bolting, or other conventional mounting methods. The shaft 24 is mounted on bearings 26 and 27. At the opposite end of the shaft 24 the pulley 28 is mounted thereon with a V-belt drive 29 passing over pulley 28 to the

pulley 30 which is rotated by means of motor 31. Within shaft 24 is a pair of bearings 18 and 19 which serve as supports for an inner shaft 14, and also acts as seals from the interior of the mixing chamber. This shaft 14 extends into the mixing chamber 10 and has mounted thereon a number of mixing members 15, which are shown as rods, but which may be knives, paddles, or blades. The opposite end of the shaft 14 has mounted thereon a pulley 20 which is driven by means of a V-belt 21 from a pulley 22 and a motor 23.

Operation of the device

When it is desired to mix particles of different materials together the various materials are placed in containers 11, 12 or 13 which are then mounted on the mixing chamber. Actuation of the motor 31 causes the mixing chamber to rotate about its horizontal axis in a counter-clockwise direction as shown in FIGURE 1; while at the same time actuation of motor 23 causes the shaft 14 and mixing rods 15 to rotate in a clockwise direction as shown in FIGURE 1. The rotation, which is fairly slow, causes the material in the uppermost container to drop vertically downward where it is distributed approximately equally between the other two containers, aided by the fairly high speed counter-rotating action of the mixing rods 15 which tend to drive the particles in the opposite direction. As the next container passes to its uppermost position it likewise drops its admixed load downward, where it is likewise distributed into the other two containers. As the third container passes upwardly it too drops its load in a similar manner. It can thus be seen that in a comparatively short length of time the particles are so thoroughly distributed that each of the containers will have a complete admixture of particles. The motors are stopped and the lowermost container is removed where it may then be utilized for the purpose originally desired. It should be realized that the ideal arrangement will provide for each container to be approximately one-third full so that the final admixture may all be contained within one container which is then removed in its lowermost position. It should also be noted that if only two dissimilar materials are to be mixed, then it is only necessary to apply these materials to two of the containers but to utilize all three in the mixing process. If more than three materials are to be mixed, more than one may be placed within the same container with the same results.

While the preferred form of the invention illustrates the use of three containers, it should be noted that four, five, six or even more could be utilized if desired in accordance with the inventive concept expressed herein.

FIGURE 3 illustrates a modified form of the invention in which the chamber instead of being hexagonal, may be triangular in cross section. In this case the mixing chamber is designated by reference numeral 40 but the containers 11, 12 and 13 are identical, as are the inner shaft 14 and the mixing rods 15. This merely illustrates some of the modifications which are possible in the practice of the present invention.

Regardless of the number of containers, the mixing chamber may be square, rectangular, round, or pentagonal in cross section, or may be any other shape which is desired. The specific shape, number of containers, or method of assembling are only incidental to the true inventive concept as described above. It is also contemplated that the shaft 14 and mixing rods may rotate in the same direction as the mixing chamber, instead of contrary thereto. Various rotational speeds may also be used to provide best results for materials of various sizes and composition. It should also be noted that the mixing shaft may be driven from the opposite side of the chamber, if desired.

Other changes may be made within the spirit of the invention.

I claim:

- 1. Apparatus for mixing particulate material comprising:
 - (a) a rotatable mixing chamber;
 - (b) material containers mounted on the outer periphery of said chamber, extending outwardly therefrom and having openings thereinto, said containers spaced 120 degrees apart around said periphery;
 - (c) a first driving means rotating said chamber and containers in a direction parallel to the plane of said containers;
 - (d) separate mixing means located within said chamber;
 - (e) a second driving means rotating said mixing means

- in a direction opposite the direction of operation of said chamber;
- (f) both of said driving means located on the same side of said chamber.
- 2. The apparatus of claim 1 in which both of said driving means are in concentric relationship.

References Cited

UNITED STATES PATENTS

| | | | | |
|-----------|--------|----------|-------|----------|
| 319,171 | 6/1885 | Barney | ----- | 259—89 |
| 2,652,983 | 9/1953 | Hall | ----- | 259—84 X |
| 2,841,370 | 7/1958 | Cosmetto | ----- | 259—89 |
| 2,901,227 | 8/1959 | Russum | ----- | 259—89 X |

ROBERT W. JENKINS, Primary Examiner.