

**(12) STANDARD PATENT**  
**(19) AUSTRALIAN PATENT OFFICE**

(11) Application No. **AU 2005291023 B2**

(54) Title  
**Improved hanging apparatus and method**

(51) International Patent Classification(s)  
**E21B 43/10** (2006.01)

(21) Application No: **2005291023** (22) Date of Filing: **2005.10.10**

(87) WIPO No: **WO06/038033**

(30) Priority Data

(31) Number **0422329.3** (32) Date **2004.10.08** (33) Country **GB**

(43) Publication Date: **2006.04.13**

(44) Accepted Journal Date: **2011.11.24**

(71) Applicant(s)  
**Caledus Limited**

(72) Inventor(s)  
**Marr, Graeme;Howlett, Paul;Wardley, Michael**

(74) Agent / Attorney  
**Chrysiliou IP Melbourne, Mount View Place Suite 6 322 Mountain Highway, Wantirna, VIC, 3152**

(56) Related Art  
**US 5131468**  
**US 4793411**  
**US 2004/0099423**

(19) World Intellectual Property Organization  
International Bureau



(43) International Publication Date  
13 April 2006 (13.04.2006)

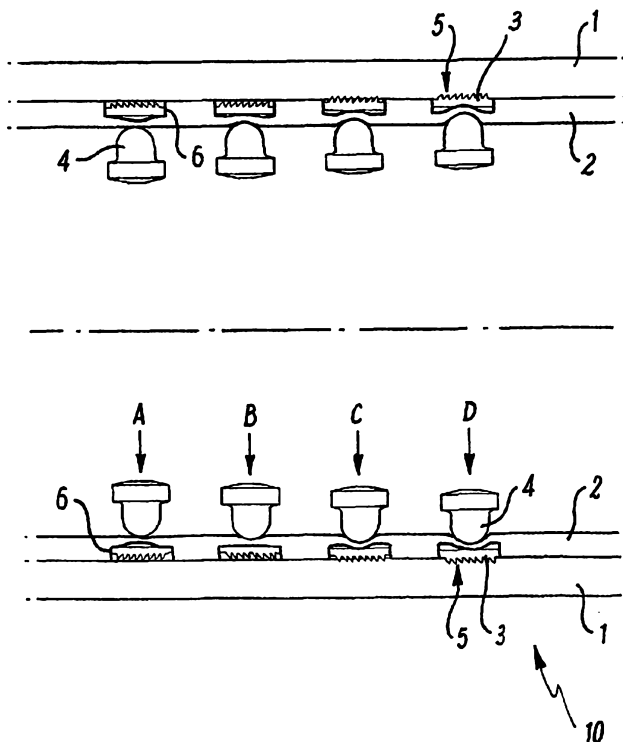
PCT

(10) International Publication Number  
WO 2006/038033 A1

- (51) International Patent Classification:  
E21B 43/10 (2006.01)
- (21) International Application Number:  
PCT/GB2005/003886
- (22) International Filing Date: 10 October 2005 (10.10.2005)
- (25) Filing Language: English
- (26) Publication Language: English
- (30) Priority Data:  
0422329.3 8 October 2004 (08.10.2004) GB
- (71) Applicant (for all designated States except US): CALEDUS LIMITED [GB/GB]; 4 Rubislaw Terrace, Aberdeen, AB10 1XE (GB).
- (72) Inventors; and
- (75) Inventors/Applicants (for US only): HOWLETT, Paul [GB/GB]; c/o Caledus Limited, 4 Rubislaw Terrace, Aberdeen AB10 1XE (GB). WARDLEY, Michael [GB/GB]; c/o Caledus Limited, 4 Rubislaw Terrace, Aberdeen AB10 1XE (GB). MARR, Graeme [GB/GB]; Caledus Limited, 4 Rubislaw Terrace, Aberdeen, AB10 1XE (GB).
- (74) Agent: KENNEDYS PATENT AGENCY LIMITED; 185 St Vincent Street, Glasgow G2 5QD (GB).
- (81) Designated States (unless otherwise indicated, for every kind of national protection available): AE, AG, AL, AM, AT, AU, AZ, BA, BB, BG, BR, BW, BY, BZ, CA, CH, CN, CO, CR, CU, CZ, DE, DK, DM, DZ, EC, EE, EG, ES, FI, GB, GD, GE, GH, GM, HR, HU, ID, IL, IN, IS, JP, KE, KG, KM, KP, KR, KZ, LC, LK, LR, LS, LT, LU, LV, LY, MA, MD, MG, MK, MN, MW, MX, MZ, NA, NG, NI, NO, NZ, OM, PG, PH, PL, PT, RO, RU, SC, SD, SE, SG, SK, SL, SM, SY, TJ, TM, TN, TR, TT, TZ, UA, UG, US, UZ, VC, VN, YU, ZA, ZM, ZW.
- (84) Designated States (unless otherwise indicated, for every kind of regional protection available): ARIPO (BW, GH, GM, KE, LS, MW, MZ, NA, SD, SL, SZ, TZ, UG, AM, ZW), Eurasian (AM, AZ, BY, KG, KZ, MD, RU, TJ, TM), European (AT, BE, BG, CH, CY, CZ, DE, DK, EE, ES, FI, FR, GB, GR, HU, IE, IS, IT, LT, LU, LV, MC, NL, PL, PT, RO, SE, SI, SK, TR), OAPI (BF, BJ, CF, CG, CI, CM, GA, GN, GQ, GW, ML, MR, NE, SN, TD, TG).

[Continued on next page]

(54) Title: IMPROVED HANGING APPARATUS AND METHOD



(57) Abstract: Apparatus, such as a liner, adapted to be hung in a downhole tubular such as casing is described. The apparatus includes one or more circumferentially distributed abrasive portions, arranged to be movable radially outwards by a dimple former or an expander. In an embodiment, the abrasive portions are provided on disks (21) movable in recesses (20) in the outer diameter (19) of the apparatus being hung. In an embodiment, the apparatus is hung by operating a dimple former provided on the running tool.

WO 2006/038033 A1



**Published:**

— with international search report

*For two-letter codes and other abbreviations, refer to the "Guidance Notes on Codes and Abbreviations" appearing at the beginning of each regular issue of the PCT Gazette.*

1 **Improved hanging apparatus and method**

2

3 The present invention relates to an apparatus and a  
4 method for hanging apparatus on the inner diameter of a  
5 downhole tubular, such as an existing casing string in a  
6 wellbore. In one of its aspects, the invention relates  
7 to an improved liner and a method of hanging a liner from  
8 an existing casing section or other tubular in a  
9 wellbore.

10

11 In the field of wellbore operations, liners are strings  
12 of pipe, used to case open holes below an existing  
13 casing. It is known to use liner hangers to anchor a  
14 liner to the inner diameter of an existing casing string.  
15 A number of techniques have been employed to meet these  
16 aims.

17

18 It is often necessary to anchor apparatus and tools other  
19 than liners in downhole tubulars, for example to cover up  
20 holes in casing. Examples include the hanging or  
21 anchoring of packers, plugs, bridge plugs, sandscreens,  
22 scab liners or other apparatus.

23

1 Generally, existing hanging methods are unsuitable for  
2 tight tolerance or close clearance casing schemes. The  
3 tolerance of standard casing is not tight enough to allow  
4 for substantial surface variations on a tubular or tool  
5 being hung, such as surface irregularities, without risk  
6 of the tubular or tool jamming within the casing.

7

8 PCT Application Number PCT/GB03/01895 describes a method  
9 and apparatus for expanding tubulars. This involves  
10 radially expanding a first smaller diameter tubular into  
11 frictional contact with a second larger diameter tubular  
12 or well bore. The disadvantage of this method is that an  
13 expanding helical band, such as therein described, is  
14 weakened as it is expanded and will part if put under too  
15 much pressure. Additionally radial deformation of the  
16 first tubular will lead to a decrease in the tensile  
17 strength of the first tubular.

18

19 US Patent Number 6,223,823 describes a method of  
20 installing a casing section in a well, where in one  
21 aspect a technique known in the art as dimpling is used.  
22 Here, discrete sections of the liner profile are forced  
23 to expand into corresponding eccentric undercuts of the  
24 existing casing in order to fix the casing being  
25 installed in the required position. This is achieved by  
26 means of forcing a number of pellets or dimple formers  
27 radially outwards into the liner.

28

29 A disadvantage of this technique is that dimpling alone  
30 is insufficient to sustain a high hanging load and  
31 slippage often occurs. Furthermore this technique  
32 requires an eccentric undercut being formed on the  
33 existing casing. This is another distinct disadvantage

2005291023 08 Nov 2011

1 as it is difficult to make such undercuts inside a casing when  
2 already in place. Therefore, such formations must be carried  
3 out well in advance, or a compatible casing must have been  
4 installed when the bore was cased.

5 The above references to and descriptions of prior proposals or  
6 products are not intended to be, and are not to be construed  
7 as, statements or admissions of common general knowledge in  
8 the art. In particular, the above prior art discussion does  
9 not relate to what is commonly or well known by the person  
10 skilled in the art, but assists in the understanding of the  
11 inventive step of the present invention of which the  
12 identification of pertinent prior art proposals is but one  
13 part.

14 It is desirable that at least one embodiment of the present  
15 invention provides an apparatus for anchoring to an existing  
16 casing string that obviates and mitigates one or more  
17 disadvantages and limitations of the prior art.

18 Moreover, it is desirable that at least one embodiment of the  
19 present invention provides a means for hanging apparatus in an  
20 existing casing string that is integral to the wall thickness  
21 of the apparatus.

22 It is a further desirable that at least one embodiment of the  
23 invention provides a method and apparatus for suspending,  
24 anchoring or hanging apparatus from the inner diameter of an  
25 existing downhole tubular in a wellbore which obviates or  
26 mitigates the disadvantages and drawbacks associated with the  
27 prior art.

28 In an aspect of the present invention, there is provided an  
29 apparatus adapted to be hung in a downhole tubular using one  
30 or more dimple formers, the apparatus comprising a tubular  
31 member of a circular cross-section having an outer surface and

2005291023 08 Nov 2011

1 an inner surface wherein the outer surface includes one or  
2 more circumferentially distributed abrasive inserts to the  
3 tubular member, the said one or more abrasive inserts located  
4 in one or more recesses on the outer surface of the circular  
5 cross-section of the tubular member, the abrasive inserts  
6 being arranged to be movable radially outwards and with  
7 respect to the outer surface of the tubular member by the  
8 dimple formers, to bring said abrasive inserts into frictional  
9 contact with a downhole tubular.

10 In another aspect, there is provided a liner, for hanging in a  
11 casing using one or more dimple formers, the liner comprising  
12 a tubular member of a circular cross-section with a hollow  
13 bore therethrough, having an outer surface and an inner  
14 surface wherein the outer surface includes one or more  
15 circumferentially distributed abrasive inserts to the tubular  
16 member, the said one or more abrasive inserts located in one  
17 or more recesses on the outer surface of the circular cross-  
18 section of the tubular member, wherein the said one or more  
19 abrasive inserts are arranged to be movable radially outwards  
20 and with respect to the outer surface of the tubular member by  
21 the dimple formers to bring said abrasive portions into  
22 frictional contact with the casing into which the liner has  
23 been inserted.

24 In yet another aspect, there is provided a method of hanging  
25 an apparatus in a downhole tubular, the method comprising the  
26 steps of:

27 (a) Running the apparatus into the downhole tubular, the  
28 apparatus comprising a tubular member of circular  
29 cross-section having an outer surface and an inner  
30 surface, wherein the outer surface comprises one or  
31 more circumferentially distributed abrasive inserts

1 located in one or more recesses on the outer surface  
2 of the circular cross-section of the tubular member;

3  
4 (b) Upon reaching a desired position in the tubular,  
5 locating one or more dimple formers on the inner  
6 surface of the tubular member corresponding to the  
7 locations of the one or more abrasive inserts on the  
8 outer surface; and

9  
10 (c) Moving the abrasive inserts radially outwards and  
11 with respect to the outer surface of the tubular  
12 member by moving the dimple formers to contact on  
13 the inner surface of the tubular member, such that  
14 the abrasive inserts are moved into frictional  
15 adherence with the downhole tubular.

16 According to a first aspect of the invention, there is  
17 provided apparatus adapted to be hung in a downhole tubular,  
18 the apparatus comprising a tubular member having an outer  
19 surface and an inner surface wherein the outer surface  
20 includes one or more circumferentially distributed abrasive  
21 portions, the said one or more abrasive portions being  
22 arranged to be movable radially outwards and with respect to  
23 the outer surface of the tubular member, to bring said  
24 abrasive portions into frictional contact with a downhole  
25 tubular.

26

27

1 In the context of this specification, the term "one or  
2 more circumferentially distributed abrasive portions"  
3 means either a single abrasive portion extending fully or  
4 partially in a circumferential direction, or a plurality  
5 of discrete abrasive portions separated  
6 circumferentially. The one or more abrasive portions may  
7 also have a degree of axial separation and/or  
8 distribution.

9

10 By increasing friction between the apparatus and the  
11 downhole tubular, this will improve the possible hanging  
12 load over that achievable by dimpling alone.

13

14 Preferably the one or more abrasive portions are disks on  
15 the outer surface of the tubular member, each comprising  
16 an abrasive surface.

17

18 Optionally the one or more abrasive portions are located  
19 in one or more recesses on the outer surface of the  
20 apparatus. Preferably the one or more recesses are  
21 machined.

22

23 Most preferably the recesses are sized that the disks are  
24 flush with the outer diameter of the tubular member.  
25 Optionally the recesses are sized that the disks are  
26 beneath the outer diameter of the tubular member.

27

28 Having the disks flush or beneath the outer diameter of  
29 the tubular member ensures that the risk of snagging  
30 between the abrasive surfaces and the downhole tubular or  
31 casing is minimised.

32

1 Most preferably the material of the one or more abrasive  
2 portions is harder than the material of the tubular  
3 member.

4

5 Optionally each abrasive surface comprises one or more  
6 formations extending from the surface of the disk to a  
7 first height, and one or more formations extending from  
8 the surface of the disk to a second height, greater than  
9 the first height.

10

11 Preferably, the one or more formations extending to the  
12 second height provides a pivot about which the disk is  
13 able to tilt on application of a force in an axial  
14 direction of the tubular member. More preferably, the  
15 one or more formations extending to the first height are  
16 shaped to provide an opposing force in an axial direction  
17 of the tubular member.

18

19 The formations extending to the first height may thereby  
20 be shaped to provide bite in an upward or lower  
21 direction. The design of the disk is bi-directional in  
22 that it provides forces opposing compressive or tensile  
23 forces applied to one or other of the tubulars.

24

25 Optionally each abrasive surface is a machined surface of  
26 the disk.

27

28 Most preferably each abrasive surface is a sequence of  
29 ridges.

30

31 Alternatively each abrasive surface is a plurality of  
32 teeth.

33

1 In a further alternative, each abrasive surface is  
2 knurled. Optionally the knurled surface is hardened.

3

4 Preferably when one abrasive portion is provided it is a  
5 single circumferential band around the liner.  
6 Advantageously a plurality of portions is provided,  
7 distributed equidistantly around the liner. This allows  
8 an abrasive portion to be provided for each dimple of the  
9 dimple former.

10

11 In a further alternative, each abrasive surface comprises  
12 one or more abrasive inserts.

13

14 Preferably the one or more inserts are made of hard  
15 steel.

16

17 Preferably the one or more recesses have a base which is  
18 spherical in relief, in order to spread the load into the  
19 one or more abrasive portions evenly.

20

21 Optionally, the apparatus is adapted to be hung in the  
22 tubular member using one or more dimple formers, and the  
23 one or more abrasive portions are arranged to be movable  
24 radially outwards by the dimple formers.

25

26 Optionally, the apparatus is adapted to be hung in the  
27 downhole tubular using one or more expanders, and the one  
28 or more abrasive portions are arranged to be movable  
29 radially outwards by employing the one or more expanders.

30

31 Preferably, the apparatus is a liner. More preferably,  
32 the the downhole tubular is casing.

33

1 According to a second aspect of the invention there is  
2 provided a liner for hanging in a casing using one or  
3 more expanders, the liner comprising a tubular member  
4 with a hollow bore therethrough, having an outer surface  
5 and an inner surface wherein the outer surface includes  
6 one or more circumferentially distributed abrasive  
7 portions, wherein the said one or more abrasive portions  
8 are arranged to be movable radially outwards and with  
9 respect to the outer surface of the tubular member by  
10 employing the one or more expanders to bring said  
11 abrasive portions into frictional contact with the casing  
12 into which the liner has been inserted.

13

14 Optionally the liner further comprises a sealing means to  
15 form a seal between the liner and the casing when the one  
16 or more expanders are employed.

17

18 Optionally the sealing means comprises a rubberised  
19 coating on the outer surface of the liner.  
20 Advantageously the rubberised coating is distinct from  
21 the abrasive portions.

22

23 In this way, when the liner is expanded the abrasive  
24 portions come into frictional contact with the casing to  
25 support the load of the hanging liner. Furthermore, the  
26 rubberised coating is trapped between the liner and the  
27 casing forming a seal.

28

29 According to a third aspect of the invention, there is  
30 provided a liner, for hanging in a casing using one or  
31 more dimple formers, the liner comprising a tubular  
32 member with a hollow bore therethrough, having an outer  
33 surface and an inner surface wherein the outer surface

1 includes one or more circumferentially distributed  
2 abrasive portions, wherein the said one or more abrasive  
3 portions are arranged to be movable radially outwards by  
4 the dimple formers to bring said abrasive portions into  
5 frictional contact with the casing into which the liner  
6 has been inserted.

7

8 Preferably, the abrasive portions are adapted to be  
9 moveable with respect to the outer surface of tubular  
10 member.

11

12 According to a fourth aspect of the invention, there is  
13 provided a method of hanging apparatus in a downhole  
14 tubular, the method comprising the steps of:

15

16 (a) Running the apparatus into the downhole  
17 tubular, the apparatus comprising a tubular  
18 member having an outer surface and an inner  
19 surface, wherein the outer surface comprises  
20 one or more circumferentially distributed  
21 abrasive portions;

22

23 (b) Upon reaching a desired position in the  
24 tubular, locating one or more dimple formers on  
25 the inner surface of the tubular member  
26 corresponding to the locations of the one or  
27 more abrasive portions on the outer surface;  
28 and

29

30 (c) Moving the abrasive portions radially outwards  
31 by moving the dimple formers to contact on the  
32 inner surface of the tubular member, such that

1           the abrasive portions are moved into frictional  
2           adherence with the downhole tubular.

3

4   Preferably, the method includes the step of moving the  
5   abrasive portions with respect to the tubular member.

6

7   Optionally, the method comprises the additional step of  
8   selecting the tubular member to have an outer diameter  
9   such as to form an interference fit with the downhole  
10   tubular.

11

12   Optionally the method comprises the step of selecting  
13   dimple formers which are located on a running tool which  
14   runs the tubular member into the downhole tubular.  
15   Alternatively the method comprises the step of selecting  
16   dimple formers which are features of a separate downhole  
17   tool run into the tubular member once it is already  
18   positioned within the downhole tubular.

19

20   In this way, the apparatus can be located and hung within  
21   the tubular in a single running operation, or can be  
22   located within the downhole tubular in one running  
23   operation then hung within the downhole tubular in a  
24   further running operation.

25

26   Preferably and advantageously, the method comprises the  
27   additional step of moving the abrasive inserts by the  
28   distance required to impress the abrasive portions into  
29   frictional adherence with the downhole tubular.

30

31   Preferably the method comprises the step of selecting a  
32   material for the one or more abrasive portions that is  
33   harder than the material of the downhole tubular.

1

2 The depth of impression required will vary depending on  
3 the tubular, the material of the apparatus, and the  
4 material and design of the abrasive inserts.

5

6 Most preferably the method comprises the step of  
7 selecting a downhole tubular that has an inner diameter  
8 machined or manufactured to a high tolerance.

9

10 Preferably the method comprises the step of selecting a  
11 liner that is machined or manufactured to form a close  
12 clearance fit within the downhole tubular.

13

14 A high tolerance inner diameter ensures that the close  
15 fitting liner is able to form as close a fit as possible  
16 while preventing the possibility of the apparatus, such  
17 as a liner, jamming within the downhole tubular. The  
18 tolerance of standard tubulars is not tight enough to  
19 ensure that the one or more abrasive portions would reach  
20 the inner diameter of the downhole tubular without the  
21 apparatus being too big to fit in the tubular.

22

23 Optionally the method comprises the step of hanging the  
24 apparatus in casing. Alternatively, the method comprises  
25 the step of hanging the apparatus in a pipe or a  
26 dedicated joint which has been deployed within a  
27 previously set tubular.

28

29 According to a fifth aspect of the invention there is  
30 provided a method of hanging apparatus in a downhole  
31 tubular, the method comprising the steps of:

32

1 (a) Running the apparatus into the downhole  
2 tubular, the apparatus comprising a tubular  
3 member having an outer surface and an inner  
4 surface, wherein the outer surface comprises  
5 one or more circumferentially distributed  
6 abrasive portions;

7  
8 (b) Upon reaching a desired position in the  
9 downhole tubular, locating one or more  
10 expanders on the inner surface of the tubular  
11 member corresponding to the locations of the  
12 one or more abrasive portions on the outer  
13 surface; and

14  
15 (c) Moving the abrasive portions radially outwards  
16 and with respect to the outer surface of the  
17 tubular member by moving the one or more  
18 expanders to contact on the inner surface of  
19 the tubular member, such that the abrasive  
20 portions are moved into frictional adherence  
21 with the downhole tubular.

22

23 Preferably the method comprises the preliminary step of  
24 coating the outer surface of the apparatus with a  
25 rubberised coating. Advantageously the method further  
26 comprises the step of ensuring that the rubberised  
27 coating is distinct from the abrasive portions.

28

29 Most preferably and advantageously the method comprises  
30 the step of selecting the one or more expanders to  
31 comprise at least two distinct diameters, one of which is  
32 larger than the inner diameter of the tubular member and

1 another of which is smaller than the inner diameter of  
2 the tubular member.

3

4 Preferably the method comprises the step of selecting the  
5 one or more expanders to be shaped as cones. Optionally  
6 the method comprises the step of selecting the one or  
7 more expanders to be shaped as conical frustums.

8

9 Preferably the method comprises the additional step of  
10 running the expander through the apparatus from bottom to  
11 top. Alternatively the method comprises the additional  
12 step of running the expander through the apparatus from  
13 top to bottom.

14

15 As the expander moves along the inner diameter of the  
16 tubular member, the tubular member is expanded by virtue  
17 of the larger diameter of the expander. The abrasive  
18 portions thus come into frictional contact with the  
19 downhole tubular or casing.

20

21 Most preferably and advantageously the method comprises  
22 the step of locating the expander within the apparatus  
23 below the abrasive portions, the smaller diameter of the  
24 expander topmost, such that the expander can be run  
25 upwards through the apparatus.

26

27 The upwards motion of the expander expands the tubular  
28 member, and in the locations where the tubular member  
29 overlaps the downhole tubular the apparatus is brought  
30 into contact with the casing. The abrasive portions thus  
31 come into frictional contact with the tubular to allow  
32 the apparatus to hang.

33

1 Preferably the method comprises the step of selecting the  
2 abrasive portions to be disks located within recesses on  
3 the outer diameter of the liner, the disks being radially  
4 movable within the recess and each disk comprising an  
5 abrasive surface.

6

7 According to a sixth aspect of the present invention,  
8 there is provided a liner for hanging in a casing using  
9 one or more expanders, the liner comprising a tubular  
10 member with a hollow bore there through, having an outer  
11 surface and an inner surface wherein the outer surface  
12 includes one or more circumferentially distributed  
13 abrasive portions, wherein the said one or more abrasive  
14 portions are arranged to be movable radially outwards by  
15 employing the one or more expanders to bring said  
16 abrasive portions into frictional contact with the casing  
17 into which the liner has been inserted.

18

19 According to a seventh aspect of the present invention,  
20 there is provided a method of hanging a liner in a  
21 tubular, comprising the steps of:

22

23 (a) Running the liner into the tubular, the liner  
24 comprising a tubular member with a hollow bore there  
25 through, having an outer surface and an inner  
26 surface, wherein the outer surface comprises one or  
27 more circumferentially distributed abrasive  
28 portions;

29

30 (b) Upon reaching a desired position in the tubular,  
31 locating one or more dimple formers on the inner  
32 surface of the liner corresponding to the locations

1 of the one or more abrasive portions on the outer  
2 surface; and

3

4 (c) Moving the abrasive portions radially outwards by  
5 moving the dimple formers to contact on the inner  
6 surface of the liner, such that the abrasive  
7 portions are moved into frictional adherence with  
8 the tubular.

9

10 According to an eighth aspect of the present invention  
11 there is provided a method of hanging a liner in a  
12 tubular, comprising the steps of:

13

14 (a) Running the liner into the tubular, the liner  
15 comprising a tubular member with a hollow bore there  
16 through, having an outer surface and an inner  
17 surface, wherein the outer surface comprises one or  
18 more circumferentially distributed abrasive  
19 portions;

20

21 (b) Upon reaching a desired position in the tubular,  
22 locating one or more expanders on the inner surface  
23 of the liner corresponding to the locations of the  
24 one or more abrasive portions on the outer surface;  
25 and

26

27 (c) Moving the abrasive portions radially outwards by  
28 moving the one or more expanders to contact on the  
29 inner surface of the liner, such that the abrasive  
30 portions are moved into frictional adherence with  
31 the tubular.

32

1 The present invention will now be described by way of  
2 example only and with reference to the accompanying  
3 figures in which;

4

5 Figure 1 illustrates in schematic form a  
6 longitudinal cross section of the liner in  
7 accordance with an aspect of the present invention;

8

9 Figure 2 illustrates in schematic form a lateral  
10 cross section of the liner in accordance with the  
11 liner of Figure 1;

12

13 Figure 3 illustrates in schematic form a  
14 longitudinal cross section of the liner in casing in  
15 accordance with the liner of Figure 1;

16

17 Figure 4 illustrates in schematic form the liner in  
18 accordance with another aspect of the present  
19 invention;

20

21 Figure 5 illustrates schematically an abrasive disk  
22 in accordance with yet another aspect of the present  
23 invention;

24

25 Figure 6 illustrates schematically an abrasive disk  
26 in accordance with an alternative aspect of the  
27 present invention;

28

29 Figure 7 illustrates schematically an expander  
30 within a liner during a hanging procedure within a  
31 casing;

32

1 Figure 8 illustrates schematically a liner that has  
2 been hung within a casing;

3

4 Figure 9 illustrates schematically a liner that has  
5 been hung within a casing, with a seal therebetween;

6

7 Figures 10A to 10C illustrate schematically an  
8 abrasive portion in accordance with an alternative  
9 embodiment of the invention;

10

11 Figures 11 and 12 illustrate schematically abrasive  
12 portions in accordance with further alternative  
13 embodiments of the invention;

14

15 Figures 13A to 13C illustrate schematically a  
16 tubular connection in accordance with an embodiment  
17 of the invention, incorporating the abrasive disk of  
18 Figure 12.

19

20 With reference to Figures 1, 2 and 3, there is presented  
21 a liner 10 that functions to anchor on existing casing 1  
22 as described in detail below.

23

24 The liner 10 comprises a hollow cylindrical body 2, a  
25 cross section of which is shown in Figure 1. In this  
26 embodiment, there are eight discrete circular recesses 6  
27 machined into the outer surface of the liner 2. The  
28 recesses are located at the upper end of the liner 2, as  
29 is indicated in Figure 3, in the section where the liner  
30 2 overlaps the casing 1. These recesses 6 are  
31 equidistantly distributed around the circumference of the  
32 outer surface of the liner 2. In this particular  
33 embodiment, the depths of the recesses 6 are half the

1 thickness of the liner 2. Additionally the bases of the  
2 recesses have a spherical relief. This combination means  
3 that the deformation of the liner 2 in the localities of  
4 the recesses 6 requires less force than in prior art  
5 liners of full thickness, as the liner 2 is considerably  
6 thinner at these points.

7

8 Additionally, the locations of the recesses 6 are chosen  
9 to coincide with the locations of the dimple formers 4  
10 being used, as shown in Figure 1. It is these dimple  
11 formers 4 which provide the radial force required to  
12 deform the liner 2 in the localities of the recesses 6.

13

14 Inside the eight recesses are located eight circular  
15 disks 3. The material of the circular disks 3 is  
16 significantly harder than the material of the liner 2 and  
17 the casing 1. Each circular disk 3 sits within its  
18 respective recess 6 such that the outermost surfaces of  
19 the circular disks 3 are flush with the outer surface of  
20 the liner 2. On the outermost surface of each circular  
21 disk 3 is a series of evenly distributed teeth 5, which  
22 are designed to be impressed into a casing 1.

23

24 As demonstrated in Figure 3, the liner 2 is inserted into  
25 an existing casing 1, with an overlap which at least  
26 covers the section including the dimple formers 4 and  
27 circular disks 3. When the liner 2 is at the desired  
28 position, the dimple formers 4 are forced radially  
29 outwards by some actuation means 7. The liner 2 is then  
30 deformed at the localities of the recesses 6 in order to  
31 force the circular disks 3 radially outwards to impress  
32 the teeth 5 into the inner surface of the casing 1.

33

1 With further reference to Figure 2, an individual dimple  
2 former 4 is shown in progressive stages of the hanging  
3 procedure. The dimple former 4 is initially at a first  
4 position A and at a final position D with intermediate  
5 positions B and C, respectively.

6

7 Position A shows the dimple former 4 and circular disk 3  
8 configuration before actuation. The dimple former 4 is  
9 located radially coincident with the recess 6, to impart  
10 as much of the radial force into deforming the liner 2 at  
11 this location.

12

13 Position B shows the relative position of the dimple  
14 former 4 immediately following actuation where slight  
15 pressure is now exerted on the inner diameter of the  
16 liner 2. The recess 6 has begun to deform, the spherical  
17 relief now deformed such that the base of the recess 6 is  
18 substantially in contact with the circular disk 3.

19

20 Position C shows how the inner diameter of the liner 2  
21 deforms under continued pressure from the dimple former 4  
22 which begins forcing the circular disk 3 outwards towards  
23 the existing casing 1. In this position the teeth 5 have  
24 started to impress into the casing 1.

25

26 Finally position D shows the dimple former 4 at its  
27 outermost extreme of travel where the inner diameter of  
28 the liner 2 has deformed sufficiently to force the teeth  
29 5 completely into the existing casing 1. The grip of the  
30 teeth 5 into the casing 1 ensures that the risk of  
31 slippage is minimal. Furthermore, a substantial portion  
32 of each of the circular disks 3 are still located within  
33 the recesses 6, which holds the liner 2 in place. As the

1 base of the recesses 5 have been deformed and are hence  
2 still in contact with the circular disks 3, there is a  
3 solid locating of the liner 2 within the casing 1 which  
4 should not slip.

5  
6 Although eight recesses 6 and eight circular disks 3 have  
7 been demonstrated in this embodiment, it will be  
8 appreciated that any number of such recesses and disks  
9 could be used. In practice, the number and indeed  
10 locations of the recesses 6 and circular disks 3 will be  
11 chosen to coincide with a particular set of dimple  
12 formers 4.

13  
14 Furthermore, it will be appreciated that the recesses 6  
15 need not be circular. For example, a hexagonal or other  
16 cornered shape could be used to locate a similarly shaped  
17 disk. This would facilitate inserting disks whose  
18 abrasive surfaces are particularly effective in a certain  
19 orientation, and thus require to be held in place to  
20 preserve this orientation.

21  
22 In alternative embodiments the disks or formations in the  
23 teeth may extend slightly from the surface of liner, to  
24 provide a degree of stand-off. Alternatively, or in  
25 addition, the recesses may be provided with an extended  
26 lip, providing stand-off from the liner outer diameter  
27 and a support for the disk as it moves outwardly from the  
28 liner.

29  
30 Figure 4 illustrates a liner 2 in accordance with another  
31 aspect of the present invention. This liner 2 has two  
32 sets of longitudinally separated abrasive portions 8.  
33 These sets comprise, in this embodiment, two discrete

1 circumferentially distributed abrasive portions 8,  
2 although it will be appreciated that any number of  
3 abrasive portions 8 can be chosen.

4

5 Each abrasive portion 8 takes the form of a spherical  
6 recess 9, machined into the outer surface of the liner 2.  
7 The depth of the spherical recess 9 corresponds to more  
8 than half of the thickness of the liner 2. However, in  
9 practice, the depth of the recess 9 will be chosen to  
10 find a suitable compromise between ease of deformation  
11 and tensile strength of the liner 2.

12

13 On the innermost surface of the spherical recess 9 is  
14 located a number of teeth 5, machined into the surface of  
15 the liner 2. The dimple formers 4, are again located  
16 radially coincident with the recesses 9. The actuation  
17 means 7, illustrated here only schematically, will force  
18 the dimple formers 4 radially outwards to impact on the  
19 inner surface of the liner 2.

20

21 As was the case with the previously discussed embodiment,  
22 the spherical recesses 9 will deform outwards towards the  
23 casing 1 (not shown) such that the teeth 5 will be  
24 impressed into the casing 1. As the teeth 5 in this  
25 embodiment form part of the liner 2, the liner 2 will  
26 thus be affixed to the casing 1.

27

28 The spherical recesses 8 provide a thinned section of  
29 liner 2 which can be deformed with less force than is  
30 required to deform an entire thickness of liner 2. The  
31 previous embodiment also offers this advantage, which is  
32 expected to reduce the risk of the actuation mechanism 7  
33 from jamming under excessive loads.

1

2 Although this embodiment demonstrates discrete spherical  
3 recesses in the outer surface of the liner, it will be  
4 appreciated that any shape of recess could be used.  
5 Furthermore, the recess could extend completely around  
6 the circumference of the liner, forming a continuous  
7 abrasive portion in the form of a band.

8

9 Indeed the location of the abrasive portions 8 and the  
10 separation of the sets of abrasive portions 8 will be  
11 chosen, in practice, to coincide with a particular set of  
12 dimple formers 4.

13

14 Figure 5 shows an abrasive disk, comprising a circular  
15 disk 11 of hard material and a series of sharp ridges 12.  
16 These sharp ridges 12 provide the abrasive surface that  
17 will impressed into the casing 1.

18

19 By choosing a material for the circular disk 11 that is  
20 harder than the liner 2, the disk should not be deformed  
21 by the liner 2 as it deforms. This will maximise the  
22 transfer of radial force into displacement of the  
23 circular disk 11.

24

25 By using a series of sharp ridges, the potential for  
26 slippage is low, as the extreme points of impression  
27 extend forming a barrier to slippage.

28

29 Figure 6 shows an alternative abrasive disk, comprising a  
30 circular disk 11 of hard material, and a plurality of  
31 uniformly distributed teeth 13. These teeth provide the  
32 abrasive surface that will impress into the casing.

33

1 Using teeth ensures that there are many discrete  
2 locations at which the disk is able to make an impression  
3 into the casing. Although the grip may not be as high as  
4 that afforded by using ridges, the likelihood of forming  
5 an impression is higher.

6

7 The disks of Figures 5 and 6 are demonstrative of two  
8 kinds of disk that can be used in the liner 2  
9 demonstrated in Figures 1 to 3.

10

11 Figure 7 shows an alternative embodiment of the present  
12 invention, in which a liner 15 is located within a casing  
13 16. The liner 15 has an upper end 17, and the casing 16  
14 a lower end 18. The liner 15 is located within the  
15 casing 16 such that there is a significant overlap region  
16 between the liner 15 and the casing 16.

17

18 Within this overlap region, machined into the outer  
19 surface 19 of the liner 15, are a number of circular  
20 recesses 20. Located within each of these recesses 20 is  
21 an abrasive disk 21. The recesses 20 are deep enough  
22 that the abrasive disks 21 sit flush with the outer  
23 surface 19 of the liner 15, as indicated at Position X.

24

25 Additionally there is an expander 22, which takes the  
26 form of a conical frustum 23, pointing upwards. The  
27 expander 22 has a base diameter 24 larger than the  
28 initial inner diameter 25 of the liner 15. When the  
29 expander 22 is moved upwards through the liner 15, the  
30 larger base diameter 24 of the expander 22 forces  
31 expansion of the inner diameter 25 of the liner, bringing  
32 the abrasive disks 21 into frictional adherence with the  
33 casing 16. This is indicated by position Y. Position X

1 indicates the initial condition of the liner 15 and  
2 abrasive disks 21 before expansion of the liner 15 by the  
3 expander 22.

4

5 Figure 8 shows the condition of the liner 15 after the  
6 expander 22 has passed completely through the liner 15.  
7 The abrasive disks 21 have been impressed into the casing  
8 16 and are supporting the hanging load of the liner 15.  
9 Figure 8 demonstrates how the hanging method leaves an  
10 annular space 26 between the liner 15 and the casing 16  
11 through which liquids or small solids would be able to  
12 flow.

13

14 The outer surface 19 of the liner 15 can be coated with a  
15 rubber material 27 and the outer diameter 28 of the liner  
16 15 chosen such that the liner 15, when expanded, forms a  
17 seal 29 between the liner 15 and the casing 16. This is  
18 demonstrated by Figure 9. The seal 29 formed by the  
19 rubber material 27 will prevent unwanted flow paths being  
20 established between the liner 15 and the casing 16.

21

22 Figures 10A to 10C illustrate schematically an abrasive  
23 disk, generally depicted at 30, in accordance with an  
24 alternative embodiment of the invention. Figure 10A  
25 shows the disk in plan view, and Figure 10B shows the  
26 cross section of the disk 30 through the line A-A.

27

28 The disk 30 is substantially circular, but has a  
29 flattened edge 31. This flattened edge 31 corresponds to  
30 the shape of the corresponding recess in the liner, and  
31 prevents the disk from being positioned in an incorrect  
32 orientation with respect to the liner. The disk is made

1 of relatively hard material, in accordance with the  
2 previously described embodiments.

3

4 As most clearly shown in Figure 10B, the disk includes a  
5 series of sharp ridges 32. In this example, three ridges  
6 are provided and include a central ridge 33, an upper  
7 ridge 34 and a lower ridge 35. The central ridge 33 is  
8 raised higher relative to the disk surface compared with  
9 the upper and lower ridges 34, 35.

10

11 The upper and lower ridges 34, 35 are shaped  
12 asymmetrically to be profiled such that the angle of  
13 inclination from the disk surface is steeper for the  
14 outer surfaces of the ridges than the angle of  
15 inclination of the inner surfaces of the ridges. This  
16 provides directionality to the upper and lower ridges as  
17 described in more detail below.

18

19 Figure 10C is a side elevation of the disk 30. In this  
20 example, the profile of the disk surface and the ridges  
21 is slightly convex, such that the height of the ridges  
22 relative to the disk base is greater along the central  
23 line A-A.

24

25 Figures 11 and 12 show disks according to alternative  
26 embodiments of the invention. In these examples, the  
27 disks are similar to the shown in Figure 10A to 10C, but  
28 differ in that they are provided with a surface profile  
29 that affects the degree of pivoting in use. In the  
30 example of Figure 11, the disk 40 is provided with upper  
31 and lower segments 42 of reduced height relative to the  
32 base of the disk. This provides clearance when the disk  
33 40 pivots around the central ridge.

1

2 In an alternative embodiment, shown in Figure 12 as disk  
3 50, upper and lower segments 52 of increased height  
4 relative to the base of the disk are provided to restrict  
5 the pivoting of the disk about the central ridge. These  
6 segments 52 of increased height may be formed of the same  
7 hardened material of the disk itself, or alternatively  
8 may be pads formed from a different material of reduced  
9 or increased hardness.

10

11 Figures 13A to 13C show schematically the disk of Figure  
12 11 in use in hanging a liner 61 from casing 62. Figure  
13 13A shows schematically the position of the disk 40 after  
14 dimple forming. The dimple 63 forces the disk 40 into  
15 engagement with the outer tubular in the manner described  
16 with reference to the embodiments of Figures 1 to 9. The  
17 ridges of the disk impress into the casing 62 as before.  
18 The raised height of the central ridge relative to the  
19 upper and lower ridges causes a greater indentation of  
20 the central ridge into the casing, by virtue of the same  
21 setting load being applied over a smaller contact area.

22

23 Figure 11B shows the arrangement of Figure 11A where a  
24 downward load is applied to the liner 61. The relative  
25 difference in the ridge heights causes the disk 40 to  
26 tilt, causing the lower ridge to come into contact with  
27 the casing and provide a force in an opposing, upward  
28 direction.

29

30 Figure 11C shows the arrangement of the Figure 11A having  
31 an upward force applied to the liner. The reversal of  
32 the load from a downward to an upward direction causes  
33 the disk to pivot over the centre ridge, allowing the

1 upper tooth to bite into the casing and provide a force  
2 in the opposing, downward direction.

3

4 The upper and lower ridges are shaped to provide bite in  
5 an upward or lower direction. The design of the disk is  
6 bi-directional in that it provides forces opposing  
7 compressive or tensile forces applied to one or other of  
8 the tubulars.

9

10 In an alternative arrangement, the disk comprises a  
11 plurality of teeth, a subset of which extend to a height  
12 above the remainder of the teeth. The subset of teeth at  
13 extended height function as the pivot in the same manner  
14 as the central ridge of the embodiments of Figures 10 to  
15 13.

16

17 The foregoing description relates to a method and  
18 apparatus for hanging a liner on a casing set into a  
19 wellbore. Although the techniques described are  
20 particularly suited to this application, the invention is  
21 not limited to such. For example, the techniques  
22 described are applicable to the hanging of a liner in a  
23 dedicated pipe or joint run in with the casing, or indeed  
24 in other downhole tubulars.

25

26 In addition, the techniques are applicable to the hanging  
27 of apparatus other than liners in downhole tubulars. For  
28 example, it may be necessary to hang packers, plugs,  
29 bridge plugs, sandscreens, scab liners or other apparatus  
30 in downhole tubulars. The arrangements of abrasive  
31 portions and the dimple forming or expanding techniques  
32 of the invention could be adapted for use in these  
33 applications.

1

2 A number of advantages can be had over the state of the  
3 art with regard to a number of features of the apparatus  
4 of the invention. In the first instance, using abrasive  
5 disks vastly improves the frictional adhesion of the  
6 apparatus to the existing casing.

7

8 A further advantage of aspects of the present invention  
9 is that scatter dimpling maintains the tensile strength  
10 of the pipe. This is because any deformation is kept to  
11 a local level, minimising unnecessary damage.

12

13 The advantage of using toothed disks in machined recesses  
14 is that less load is required to push the teeth into the  
15 casing by a fixed displacement than to deform an entire  
16 thickness of the tubular member into the existing casing.  
17 This offers the additional advantage that as the load is  
18 not too high the actuation tool is less likely to jam.

19

20 A further advantage of the present invention is that the  
21 hanging can be achieved without it being necessary to  
22 modify the existing casing or casing the wellbore with a  
23 specifically designed tubular.

24

25 Furthermore, techniques like nitride hardening, which is  
26 one of the best available hardening methods, can be used  
27 for discrete abrasive portions to increase the local  
28 hardness. Otherwise this technique could not  
29 realistically be used as if the whole circumference was  
30 hardened in this way then upon expansion the tubular  
31 member would shatter.

32

08 Nov 2011

2005291023

1 The principal advantage of the present invention is that it  
2 provides anchoring of apparatus to an existing downhole  
3 tubular with sufficient strength to sustain a substantial  
4 hanging load while maintaining the tensile strength of the  
5 apparatus and downhole tubular. Furthermore, it will be of  
6 particular benefit to anchoring expandable tubulars whereby  
7 the use of abrasive portions will increase the hanging load  
8 that can be supported.

9

10 Further modifications and improvements may be added without  
11 departing from the scope of the invention herein described.  
12 For example the reverse process may be carried out whereby  
13 abrasive portions for gripping surfaces are dimpled or  
14 deformed inwards from the casing to the self contained liner.  
15 Furthermore, the expander might take an alternative form, for  
16 example a ball or a dart.

17

18 Throughout the specification and claims the word "comprise"  
19 and its derivatives are intended to have an inclusive rather  
20 than exclusive meaning unless the contrary is expressly stated  
21 or the context requires otherwise. That is, the word  
22 "comprise" and its derivatives will be taken to indicate the  
23 inclusion of not only the listed components, steps or features  
24 that it directly references, but also other components, steps  
25 or features not specifically listed, unless the contrary is  
26 expressly stated or the context requires otherwise.

Claims

1. An Apparatus adapted to be hung in a downhole tubular using one or more dimple formers, the apparatus comprising a tubular member of a circular cross-section having an outer surface and an inner surface wherein the outer surface includes one or more circumferentially distributed abrasive inserts to the tubular member, the said one or more abrasive inserts located in one or more recesses on the outer surface of the circular cross-section of the tubular member, the abrasive inserts being arranged to be movable radially outwards and with respect to the outer surface of the tubular member by the dimple formers, to bring said abrasive inserts into frictional contact with a downhole tubular.
2. The apparatus as claimed in Claim 1 wherein the material of the one or more abrasive inserts is harder than the material of the tubular member.
3. The apparatus as claimed in Claim 1 or Claim 2 wherein the one or more abrasive inserts are disks, each disk comprising an abrasive surface.
4. The apparatus as claimed in any preceding Claim wherein the one or more recesses are machined.

30

2005291023 08 Nov 2011

5. The apparatus as claimed in Claim 3 or Claim 4 wherein the recesses are sized such that the disks are flush with the outer diameter of the tubular member.
- 5
6. The apparatus as claimed in Claim 3 or Claim 4 wherein the recesses are sized such that the disks are beneath the outer diameter of the tubular member.
- 10
7. The apparatus as claimed in any preceding Claim wherein the one or more recesses have a base which is spherical in relief.
- 15
8. The apparatus as claimed in any one of Claims 3 to 7 wherein each abrasive surface is a machined surface of the disk.
- 20
9. The apparatus as claimed in any one of Claims 3 to 8 wherein each abrasive surface comprises one or more formations extending from the surface of the disk to a first height, and one or more formations extending from the surface of the disk to a second height, greater than the first
- 25
- height.
- 30
10. The apparatus as claimed in Claim 9 wherein one or more formations extending to the second height provides a pivot about which the disk is able to tilt on application of a force in an axial direction of the tubular member.

2005291023 08 Nov 2011

11. The apparatus as claimed in Claim 9 or Claim 10  
wherein one or more formations extending to the  
first height are shaped to provide a force on the  
5 tubular member having a component in an axial  
direction of the tubular member.
12. The apparatus as claimed in any one of Claims 9  
to 11 wherein the one or more formations  
10 extending from the surface of the disk to the  
first height and the one or more formations  
extending from the surface of the disk to the  
second height comprise a series of ridges.
13. The apparatus as claimed in any one of Claims 9  
to 12 wherein the formations comprise a plurality  
15 of teeth.
14. The apparatus as claimed in any of Claims 3 to 13  
20 wherein each abrasive surface is knurled.
15. The apparatus as claimed Claim 14 wherein the  
knurled surface is hardened.
16. The apparatus as claimed in any preceding Claim  
25 wherein a plurality of abrasive inserts is  
provided, the abrasive inserts being distributed  
equidistantly around the tool.

- 2005291023 08 Nov 2011
17. The apparatus as claimed in any preceding Claim wherein the one or more abrasive inserts comprise hardened steel.
- 5 18. The apparatus as claimed in any preceding Claim wherein the apparatus is a liner.
19. The apparatus as claimed in any preceding Claim wherein the downhole tubular is casing.
- 10 20. A liner, for hanging in a casing using one or more dimple formers, the liner comprising a tubular member of a circular cross-section with a hollow bore therethrough, having an outer surface and an inner surface wherein the outer surface includes one or more circumferentially distributed abrasive inserts to the tubular member, the said one or more abrasive inserts located in one or more recesses on the outer surface of the circular cross-section of the tubular member, wherein the said one or more abrasive inserts are arranged to be movable radially outwards and with respect to the outer surface of the tubular member by the dimple formers to bring said abrasive portions into frictional contact with the casing into which the liner has been inserted.
- 15 20
- 25 21. A method of hanging an apparatus in a downhole tubular, the method comprising the steps of:
- 30

2005291023 08 Nov 2011

- 5
- 10
- 15
- 20
- 25
- 30
- (a) Running the apparatus into the downhole tubular; the apparatus comprising a tubular member of circular cross-section having an outer surface and an inner surface, wherein the outer surface comprises one or more circumferentially distributed abrasive inserts located in one or more recesses on the outer surface of the circular cross-section of the tubular member;
- (b) Upon reaching a desired position in the tubular, locating one or more dimple formers on the inner surface of the tubular member corresponding to the locations of the one or more abrasive inserts on the outer surface; and
- (c) Moving the abrasive inserts radially outwards and with respect to the outer surface of the tubular member by moving the dimple formers to contact on the inner surface of the tubular member, such that the abrasive inserts are moved into frictional adherence with the downhole tubular.
22. The method as claimed in Claim 21 comprising the additional step of selecting the apparatus to have an outer diameter such as to form an interference fit with the downhole tubular.

08 Nov 2011

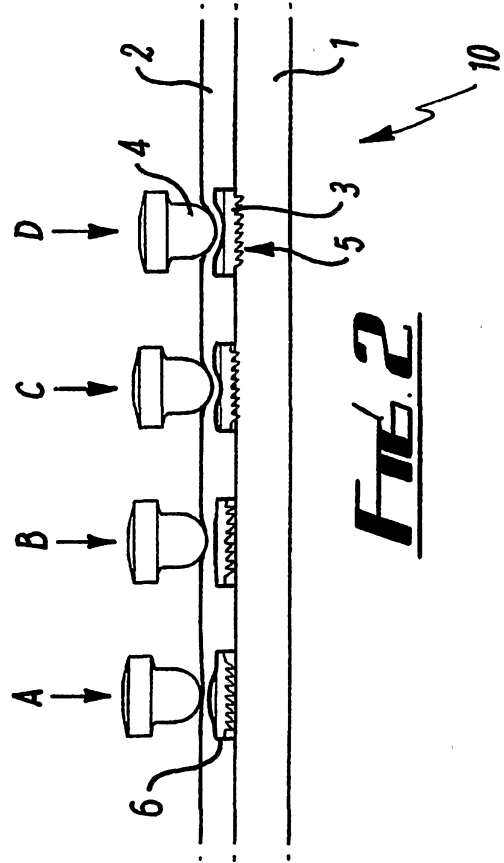
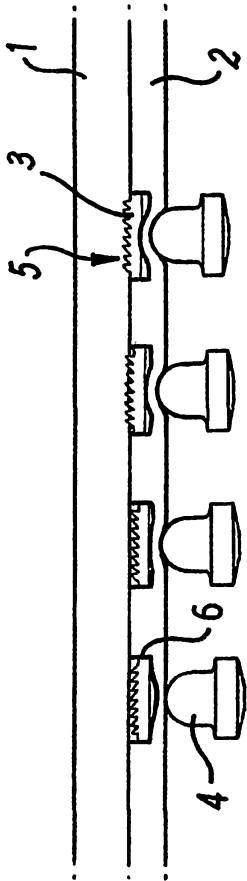
2005291023

23. The method as claimed in Claim 21 or Claim 22  
comprising the step of using dimple formers  
located on a running tool which runs the  
apparatus into the downhole tubular.  
5
24. The method as claimed in Claim 21 or Claim 22  
comprising the step of using dimple formers on a  
separate downhole tool run into the apparatus,  
once the apparatus is positioned in the downhole  
tubular.  
10
25. The method as claimed in any of Claims 21 to 24  
comprising the additional step of moving the  
abrasive inserts by the distance required to  
impress the abrasive portions into frictional  
adherence with the downhole tubular.  
15
26. The method as claimed in any of Claims 21 to 25  
comprising the step of selecting a downhole  
tubular that has an inner diameter machined or  
manufactured to a high tolerance.  
20
27. The method as claimed in Claims 21 to 26  
comprising the step of selecting apparatus that  
is machined or manufactured to form a close  
clearance fit within the downhole tubular.  
25
28. The method as claimed in any of Claims 21 to 27  
wherein the downhole tubular is casing.  
30

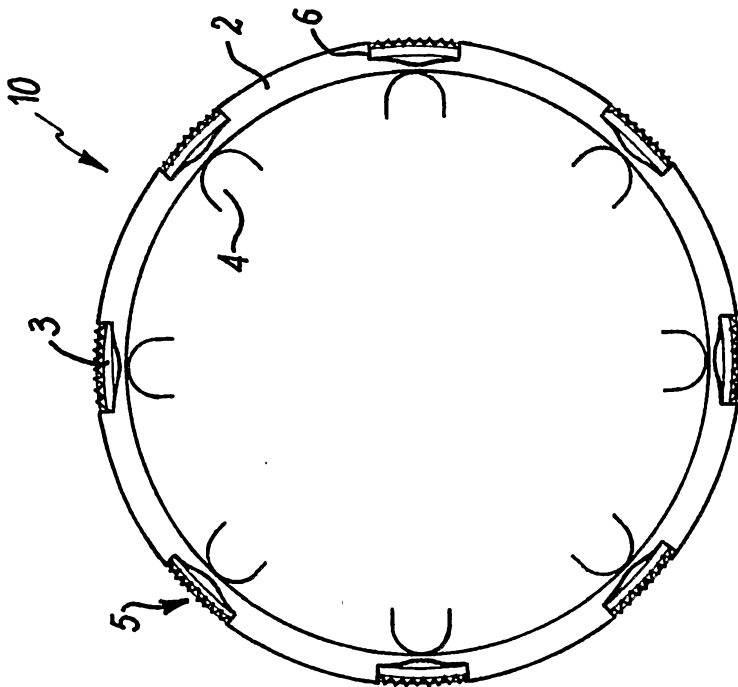
29. The method as claimed in any of Claims 21 to 26 wherein the downhole tubular is a pipe or a dedicated joint which has been deployed within a previously set tubular.

5

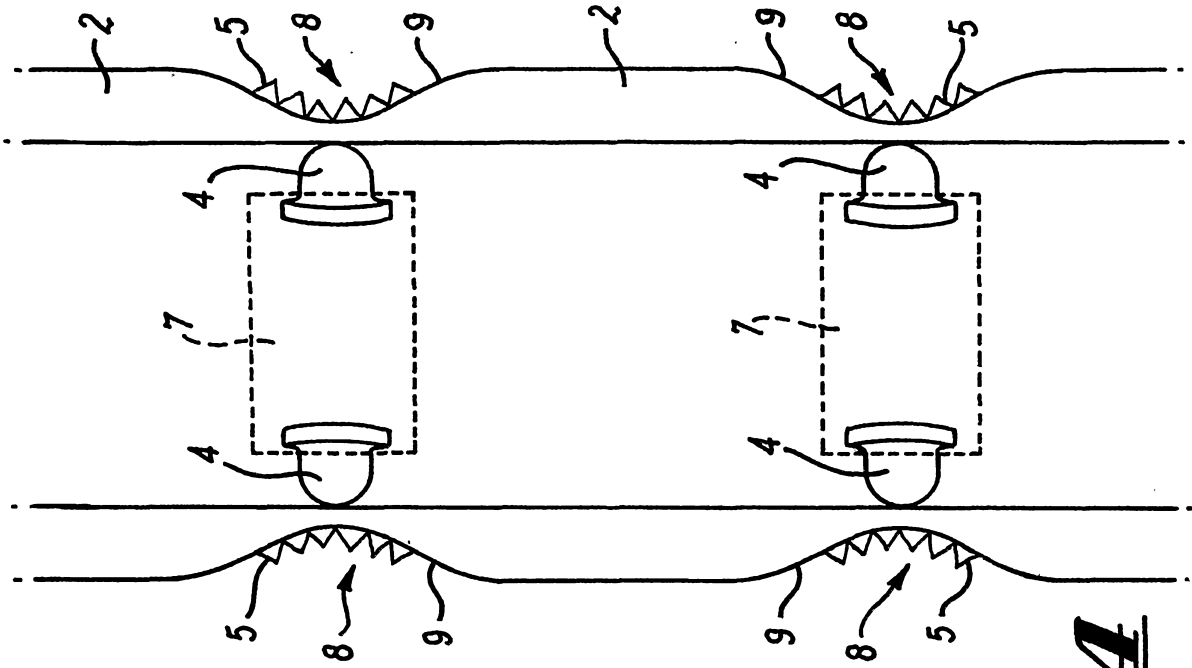
2005291023 08 Nov 2011



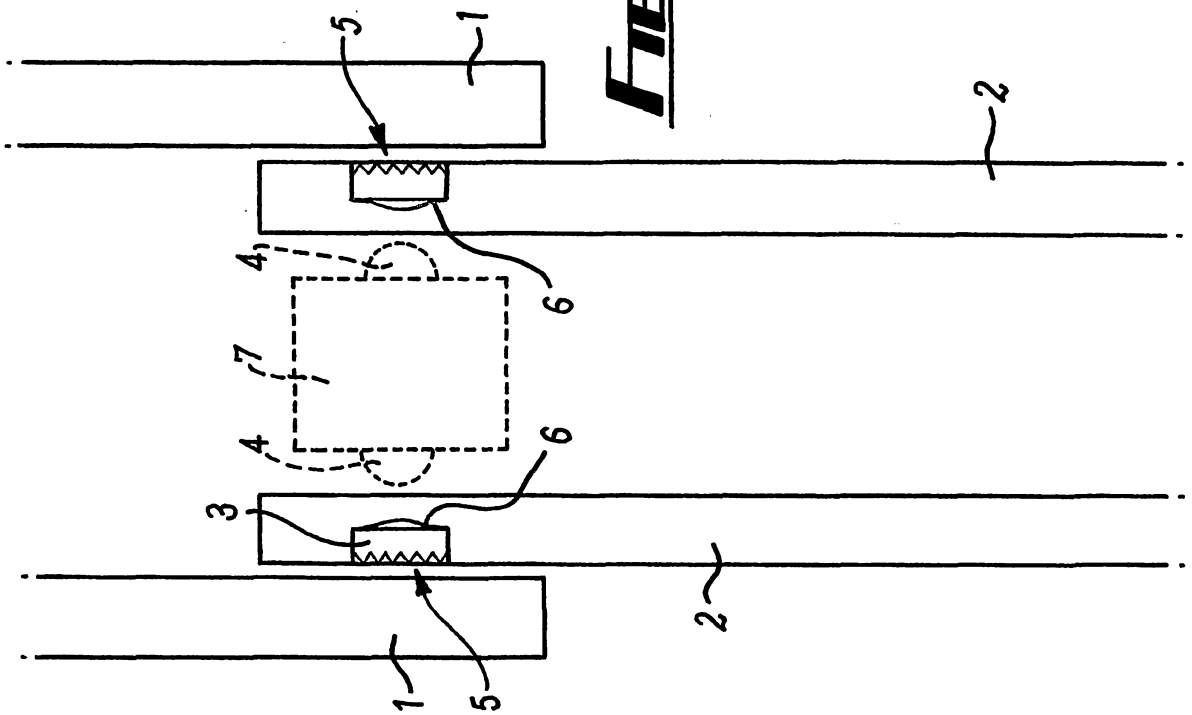
**FIG. 2**



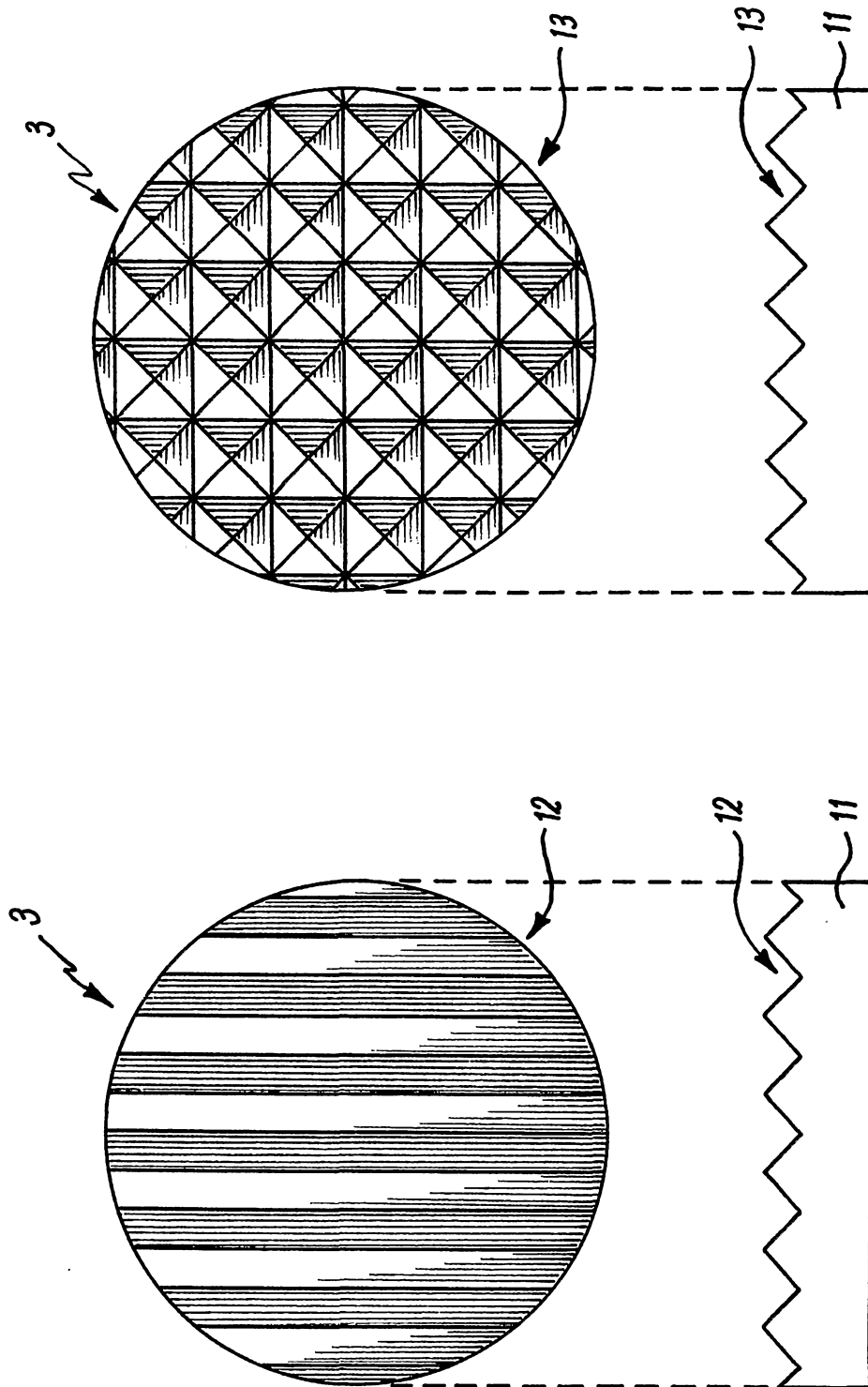
**FIG. 1**



**FIG. 4**

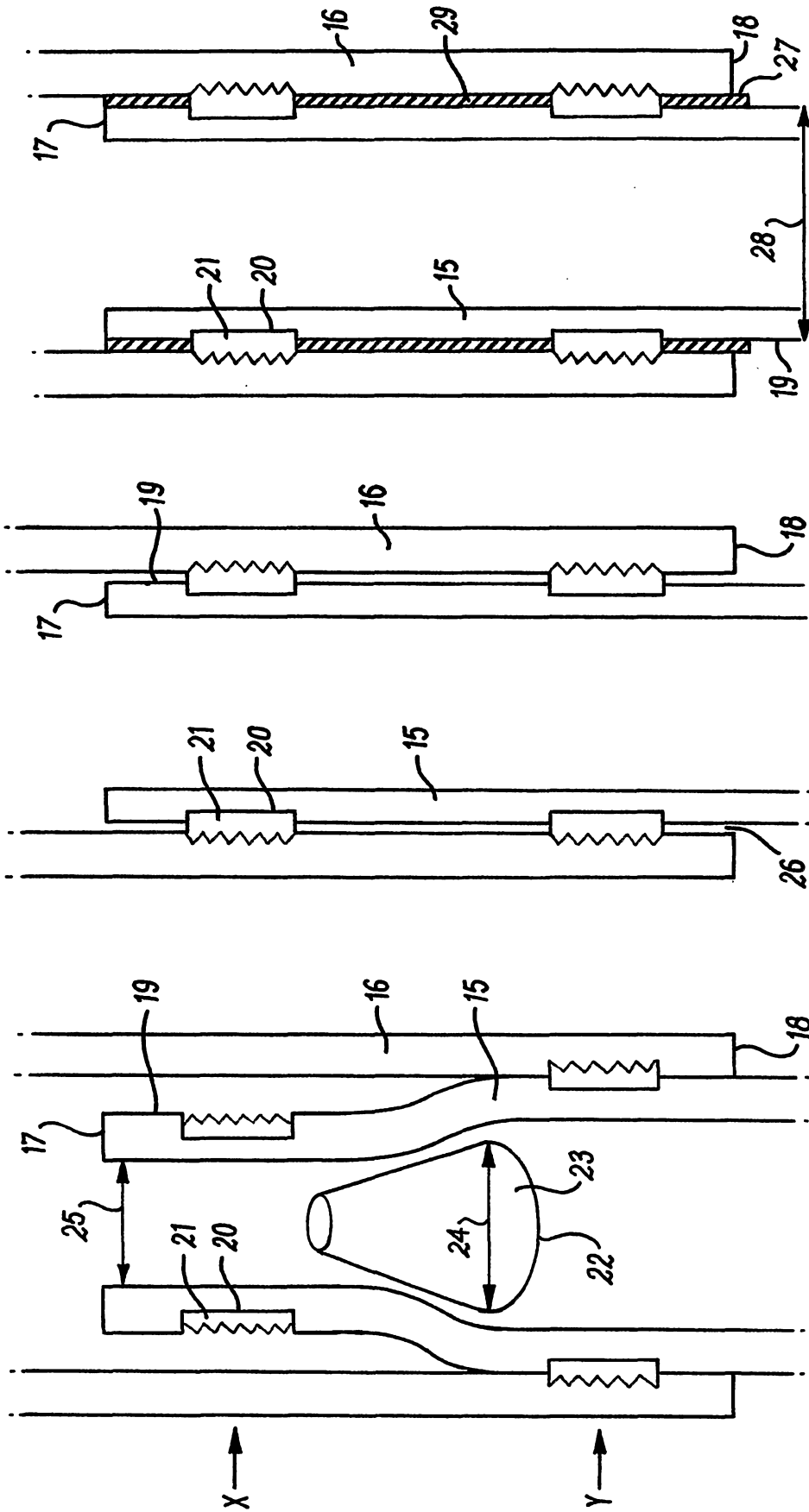


**FIG. 3**



**FIG. 6**

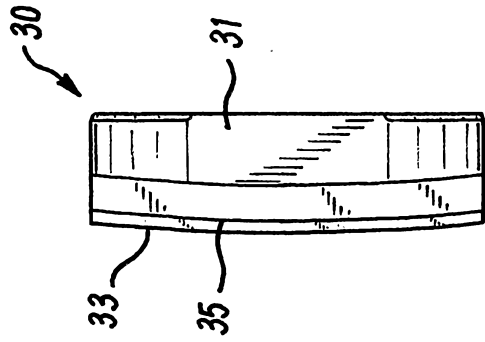
**FIG. 5**



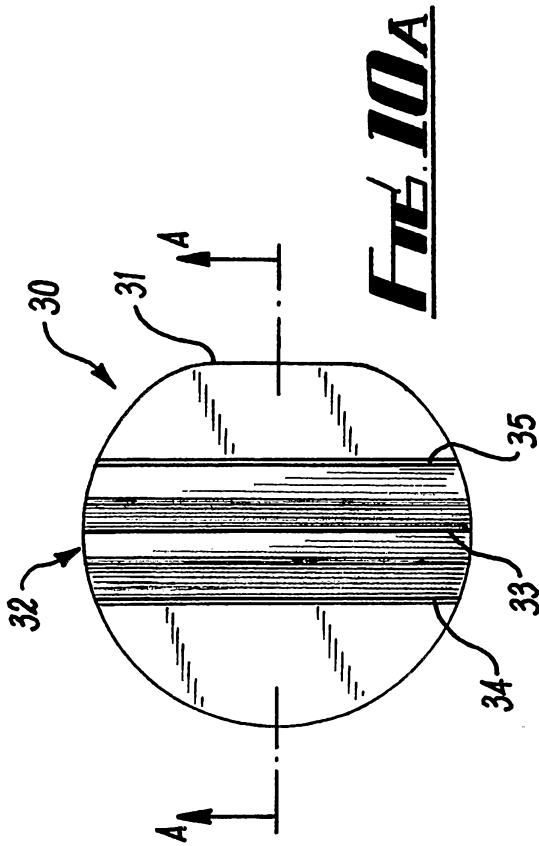
**FIG. 9**

**FIG. 8**

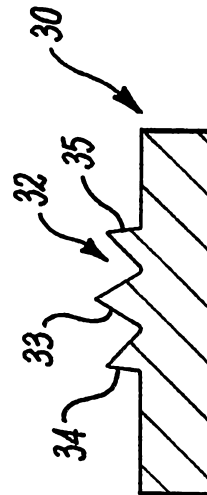
**FIG. 1**



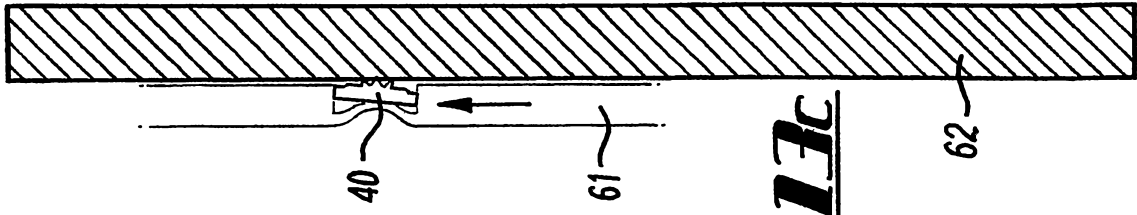
**FIG. 10C**



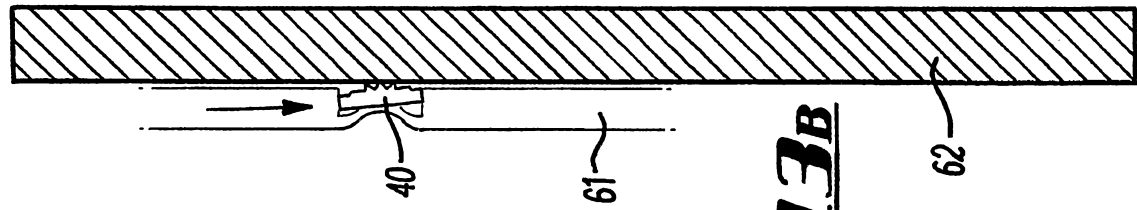
**FIG. 10A**



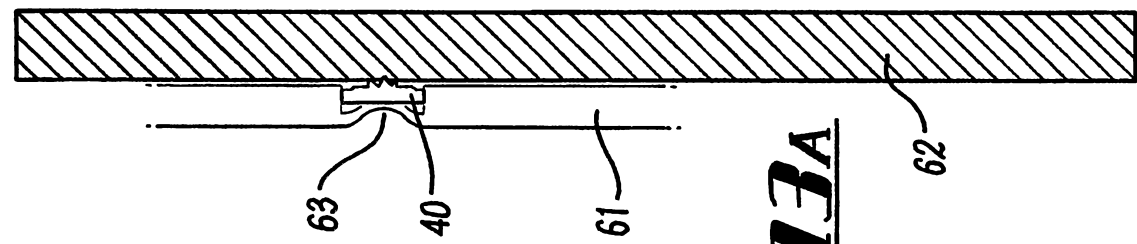
**FIG. 10B**



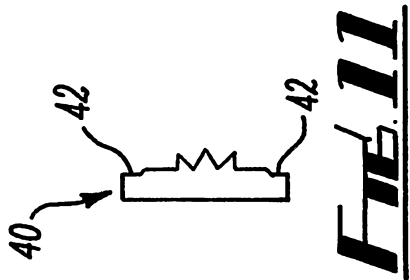
**FIG. 13C**



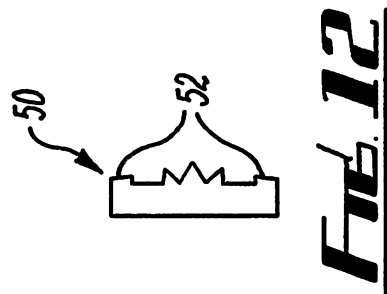
**FIG. 13B**



**FIG. 13A**



**FIG. 11**



**FIG. 12**