



(11) **EP 2 479 903 B1**

(12) **EUROPEAN PATENT SPECIFICATION**

(45) Date of publication and mention of the grant of the patent:
16.11.2016 Bulletin 2016/46

(51) Int Cl.:
H04B 7/216 ^(2006.01) **H04B 7/208** ^(2006.01)
H04J 3/00 ^(2006.01) **H04W 52/32** ^(2009.01)
H04L 1/16 ^(2006.01) **H04L 7/106** ^(2006.01)
H04W 24/06 ^(2009.01)

(21) Application number: **12164537.8**

(22) Date of filing: **13.06.2002**

(54) **Method and apparatus for the transmittal of heartbeat signal at a lower level than heartbeat request**

Verfahren und Vorrichtung zur Senden eines Herzschlagsignals mit einem niedrigeren Pegel als eine Herzschlaganforderung

Procédé et appareil pour la transmission de signal de pulsation à un niveau inférieur à celui d'une demande de signal de pulsation

(84) Designated Contracting States:
AT BE CH CY DE DK ES FI FR GB GR IE IT LI LU MC NL PT SE TR

(30) Priority: **13.06.2001 US 297925 P**
29.11.2001 US 997621
07.05.2002 US 378697 P
12.06.2002 US 171080

(43) Date of publication of application:
25.07.2012 Bulletin 2012/30

(62) Document number(s) of the earlier application(s) in accordance with Art. 76 EPC:
02752051.9 / 1 396 158

(73) Proprietor: **Intel Corporation**
Santa Clara, CA 95054 (US)

(72) Inventor: **Proctor, James A.**
Melbourne Beach, FL 32951 (US)

(74) Representative: **HGF Limited**
Fountain Precinct
Balm Green
Sheffield S1 2JA (GB)

(56) References cited:
EP-A2- 0 475 698 WO-A1-00/57663
WO-A1-97/49201 WO-A2-99/63682
US-A1- 2001 036 200

EP 2 479 903 B1

Note: Within nine months of the publication of the mention of the grant of the European patent in the European Patent Bulletin, any person may give notice to the European Patent Office of opposition to that patent, in accordance with the Implementing Regulations. Notice of opposition shall not be deemed to have been filed until the opposition fee has been paid. (Art. 99(1) European Patent Convention).

Description

BACKGROUND OF THE INVENTION

5 [0001] Increasing use of wireless telephones and personal computers has led to a corresponding increase in demand for advanced telecommunication services that were once thought practical only for specialized applications. In the 1980s, wireless voice communications became widely available through cellular telephone networks. Such services were thought at first to be for the exclusive province of businessmen because of expected high subscriber costs. The same was also true for access to remotely distributed computer networks, whereby until very recently, only business people and large

10 institutions could afford the necessary computers and wireline access equipment.
[0002] As a result of the widespread availability of affordable new technologies, the general population now increasingly desires to have not only wireline access to networks such as the Internet and private intranets, but also wireless access as well. Wireless technology is particularly useful to users of portable computers, laptop computers, hand-held personal digital assistants and the like who prefer access to such networks without being tethered to a telephone line.

15 [0003] There still is no widely available satisfactory solution for providing low cost, high speed access to the Internet, private intranets, and other networks using the existing wireless infrastructure. This is most likely an artifact of several unfortunate circumstances. First, the typical manner of providing high speed data service in the business environment over a wireline network is not readily adaptable to the voice grade service available in most homes or offices. For example, such standard high speed data services do not necessarily lend themselves to efficient transmission over standard cellular wireless handsets because wireless networks were originally designed only to provide voice services. As a result, present day digital wireless communications systems are optimized for voice transmissions, although certain schemes such as CDMA do provide some measure of asymmetrical behavior for the accommodation of data transmissions. For example, the data rate specified by the Telecommunication Industry Association (TLA) for IS-95 on the forward traffic channel is adjustable in increments from 1.2 kbps up to 9.6 kbps for so-called Rate Set 1, and increments from 1.8 kbps

20 up to 14.4 kbps for Rate Set 2. On the reverse link traffic channel, however, the data rate is fixed at 4.8 kbps.
[0004] At best, existing wireless systems therefore typically provide a radio channel that can accommodate maximum data rate transfers of 14.4 kilobits per second (kbps) over a forward link direction. Such a low data rate channel does not lend itself directly to transmitting data at rates of 28.8 or even 56.6 kbps that are now commonly available using inexpensive wireline modems, not to mention even higher rates such as the 128 kbps that are available with Integrated Services Digital Network (ISDN) type equipment. Data rates at these levels are rapidly becoming the minimum acceptable rates for activities such as browsing web pages.

25 [0005] Although wireline networks were known at the time when cellular systems were initially developed, for the most part, there was no provision made for such wireless systems to provide higher speed ISDN- or ADSL-grade data services over cellular network topologies.

30 [0006] In most wireless systems, there are many more potential users than radio channel resources. Some type of demand-based multiple access system is therefore required.

[0007] Whether the multiple access is provided by the traditional Frequency Division Multiple Access (FDMA) using analog modulation on a group of radio frequency carrier signals, or by schemes that permit sharing of a radio carrier frequency using Time Division Multiple Access (TDMA), or Code Division Multiple Access (CDMA), the nature of the radio spectrum is such that it is expected to be shared. This is quite dissimilar to the traditional environment supporting data transmissions in which the wireline medium is relatively inexpensive and is not typically intended to be shared.

35 [0008] Other factors to consider in the design of a wireless system are the characteristics of the data itself. For example, consider that access to web pages generally is burst-oriented, with asymmetrical data rate transmission requirements in a reverse and forward direction. In a common application, a user of a remote client computer first specifies the address of a web page to a browser program. The browser program then sends the web page address data, which is usually 100 bytes or less in length, over the network to a server computer. The server computer then responds with the content of the requested web page, which may include anywhere from 10 kilobytes to several megabytes of text, image, audio, or even video data. The user thereafter may spend several seconds or even several minutes reading the content of the page before downloading another web page.

40 [0009] In an office environment, the nature of most employees' computer work habits is typically to check a few web pages and then to do something else for an extended period of time, such as accessing locally stored data or even terminating use of the computer altogether. Therefore, even though such users may remain connected to the Internet or private intranet continuously during an entire day, actual use of the high speed data link is usually quite sporadic.

45 [0010] If wireless data transfer services supporting Internet connectivity are to coexist with wireless voice communication, it is becoming increasingly important to optimize the use of available resources in wireless CDMA systems. Frequency reuse and dynamic traffic channel allocation address some aspects of increasing the efficiency of high performance wireless CDMA communication systems, but there is still a need for more efficient utilization of available resources.

[0011] WO 97/49201 relates to a synchronous discontinuous transmission medium access control method and apparatus. The disclosed method shares uplinks channels between multiple terminals engaged in bursty data transmission. Terminals are assigned time slots allowing a transmitting terminals identity to be determined by the timeslot used for a transmission.

5 [0012] WO 99/63682 describes a service option overlay for CDMA wireless communication in which multiple allocable subchannels may be dynamically divided between subscriber units to match the instantaneous bandwidth needs of the subscriber units.

[0013] WO 00/57663 describes a method for a mobile station to access a base station using a randomly chosen random access channel.

10 [0014] EP 0475698 relates to a communication system that performs radio channel management to reduce contribution and superfluous channel allocation between a plurality of mobile units.

SUMMARY OF THE INVENTION

15 [0015] In one application, a transmission of a marker in a time slot over one channel indicates a request by the corresponding field unit to go active. That is, transmission of a marker in an assigned time slot indicates that the field unit is requesting that reverse link traffic channels be assigned to the user for transmitting a data payload from the field unit to the base station. This presumes that the field unit is presently in the standby mode. Alternatively, a field unit transmits a marker over a second channel of the pair of reverse link channels to indicate that the field unit is not requesting to be placed in the active mode. For example, the field unit does not want to transmit data on a reverse link channel. Rather, the field unit requests to remain inactive but synchronized with the base station so that the field unit can immediately go active again at any moment.

20 [0016] In either case, a wireless communications system employing the principles of the present invention may improve performance of detecting the markers by having the field units transmit the markers at different power levels (e.g., 9 dB for one marker and 11 dB for the other marker), which can improve system performance. The difference in power levels of the markers allows the base station to identify the request markers using alternative criteria with a low probability of error, where the alternative criteria may include comparing the markers to respective energy level thresholds, monitoring occupancy of time slots, occupancy of mutually exclusive code channels, or combinations thereof. For example, in one particular embodiment, a request marker, which is generally a high priority marker, is transmitted with higher power, which improves the probability of detection and reduces the probability of false detection of the request marker.

25 [0017] In one particular CDMA system application, the field unit provides a Heartbeat (HB) channel using a first code in a reverse link to the base station and a heartbeat-with-request (HB/RQST) channel using a second code in the reverse link. In this CDMA application, according to the principles of the present invention, the field unit may transmit the HB and HB/RQST channels with a difference in power levels, preferably giving the HB/RQST the higher power since it is a higher priority signal.

30 [0018] The teachings of the present invention support I-CDMA and 1xEV-DV systems, but are general enough to support systems employing various other communications protocols used in wired or wireless communications systems. Code Division Multiple Access (CDMA) systems, such as IS-2000, and Orthogonal Frequency Division Multiplexing (OFDM) systems, such as IEEE 802.11a wireless local area network (LAN), may employ an embodiment of the present invention.

BRIEF DESCRIPTION OF THE DRAWINGS

35 [0019] The foregoing and other objects, features and advantages of the invention will be apparent from the following more particular description of preferred embodiments of the invention, as illustrated in the accompanying drawings in which like reference characters refer to the same parts throughout the different views. The drawings are not necessarily to scale, emphasis instead being placed upon illustrating the principles of the invention.

40 Fig. 1 is a schematic diagram of a communications system in which in an embodiment of the present invention may be deployed;

Fig. 2 is a schematic diagram of a subsystem employed by a base station in the communications system of Fig. 1 used to determine whether a reverse link signal includes an indication for a request to change communications states based on an energy level in the signal;

45 Fig. 3A is a signal diagram of a 1xEV-DV signal with a first marker indicating 'control hold' and a second marker indicating a 'request to go active';

Fig. 3B is a signal diagram of a code division multiple access (CDMA) set of code channels having a marker in an assigned time slot that indicates that the field unit is requesting a change in communications states;

Fig. 3C is a signal diagram of an alternative embodiment of a reverse link signal having the indications; and

Fig. 4 is a plot of signal-to-noise ratio versus probability of detection that may be used in determining energy levels of the indications in the signals of Figs. 3A-3C.

DETAILED DESCRIPTION OF THE INVENTION

5 [0020] A description of preferred embodiments of the invention follows.

10 [0021] In a wireless communications system, an embodiment of the present invention applies to the power that is transmitted from a handset (or the target received power at a base terminal station (BTS)) for a Heartbeat signal (HB) versus a Heartbeat-with-Request signal (HBR, HB/RQST, or just the "request" signal). The HB and HB/RQST signals may be transmitted on a maintenance channel, which, as disclosed in U.S. Serial No. 09/775,305, is a single code channel (out of many) on a reverse link of a CDMA communications system. The maintenance channel is time slotted and different users are assigned different slots.

15 [0022] A field unit in that wireless communications system sends a heartbeat signal to maintain timing and/or power control as well as an indication of presence to the BTS. When a terminal needs an assigned reverse link channel, the terminal then transmits at least one request signal. The signal(s) may be modulated messages or simply coded pilot signals with no "bits".

20 [0023] The requirements for probability of detection and probability of false detection for these channels are quite different. For instance, the detection requirement for HB is relatively low. It may only need to be detected at a rate that is fast enough to track the slew of the timing of the code channel due to physical movement of multi-path structure change resulting from Doppler in the channel. The power control in this case continues to work independent of detection or lack of detection.

25 [0024] For instance, if the signal is not "detected" because the received power is not above a predetermined threshold but the correlation is aligned, the power command indicates that the power was too low and that the terminal should "power up". One requirement, in this particular embodiment, is that the detection occur often enough to allow the detector to be aligned in time to the received signal.

30 [0025] On the other hand, the probability of detection for the request signal is preferably very high as a request signal is considered a high priority signal since a request is an urgent event. Therefore, the request signal may be sent with higher power, and the threshold at the BTS may be set differently. This results in a better probability of detection as well as a low probability of false detection.

35 [0026] Thus, according to the principles of the present invention, a different probability of detection and probability of false detection for the heartbeat signal, request signal, or any other signaled message can be employed.

[0027] Based on the signal type, an access terminal can transmit the signals with different powers. Various criteria can be used by the BTS for detecting indications of a request sent on the signals. For example, in time slotted channels or mutually exclusive code channels, some slots are occupied when a request is being made versus when a request is not being made. In such a case, either a higher power, presence, or both may be used as detection criteria.

40 [0028] Fig. 1 is a diagram of an example communications system 100, similar to the system described above, employing an embodiment of the present invention. A base station 25 with antenna tower 23 maintains wireless communications links with each of a plurality of field units 42a, 42b, 42c (collectively, field units 42) as shown.

[0029] Such wireless links are established based upon assignment of resources on a forward link 70 and a reverse link 65 between the base station 25 and field units 42. Each link 65 or 70 is typically made up of several logical reverse link channels 55 and several logical forward link channels 60, respectively.

45 [0030] As shown, the communications system 100 supports wireless communications between an interface 50 and a network 20. Typically, the network 20 is a Public Switched Telephone Network (PSTN) or computer network, such as the Internet, internet, or intranet. The interface 50 is preferably coupled to a digital processing device, such as a portable computer 12, sometimes referred to as an access unit, to provide wireless access to the network 20. Consequently, the portable computer 12 has access to the network 20 based on communications over a combination of both hard-wired and wireless data links.

50 [0031] In a preferred embodiment, the forward link channels 60 and reverse link channels 55 are defined in the communications system 100 as Code Division Multiple Access (CDMA) channels. That is, each CDMA channel is preferably defined by encoding and transmitting data over the channel with an augmented pseudo random noise (PN) code sequence. The PN coded data is then modulated onto a radio frequency carrier. This enables a receiver to decipher one CDMA channel from another knowing only the particular augmented PN code assigned for a given channel. In accordance with an embodiment, each channel may occupy a 1.25 MHz band consistent with the IS-95 CDMA standard and 1xEV-DV standard and is capable of transmitting at 38.4 kbps.

55 [0032] A forward link 70 includes at least four logical forward link channels 60. As shown, this includes a Pilot Channel 60PL, Link Quality Management (LQM) channel 60L, paging channel 60PG, and multiple traffic channels 60T.

[0033] A reverse link 65 includes at least five logical reverse link channels 55. As shown, this includes a heartbeat standby channel 55HS, heartbeat request active channel 55HRA, access channel 55A and multiple traffic channels 55T.

Generally, the reverse link channels 55 are similar to the forward link channels 60 except that each reverse link traffic channel 60T can support variable data rates from 2.4 kbps to a maximum of 160 kbps.

[0034] Data transmitted between the base station 25 and field unit 42a typically consist of encoded digital information, such as web page data. Based on the allocation of multiple traffic channels in the reverse link 65 or forward link 70, higher data transfer rates can be achieved in a particular link between the base station 25 and field unit 42a. However, since multiple field units 42 complete for bandwidth allocation, a field unit 42a may have to wait until resources are free to be assigned traffic channels to transmit a data payload.

[0035] Before discussing an example detector system (Fig. 2) that can be used to distinguish a heartbeat from a heartbeat-with-request signal, a brief discussion of example signals will be discussed in reference to Figs. 3A-3C.

[0036] In Fig. 3A, a 1xEV-DV signal 160 that may be transmitted by the field unit is shown having three distinct states: a 'control hold' state 165, a 'request to go active' state 170, and a data traffic state 175. In the 'control hold' state 165, the signal 160 does not include a 'request to go active' indication. In other words, the signal 160 remains in an 'idle' or 'control hold' state, which indicates that the field unit 42a is not requesting traffic channels. The 'request to go active' state 170 is an indication that the field unit is requesting to transmit data on a traffic channel over a reverse link to the BTS 25. In the traffic state 175, traffic data is transmitted by the field unit to the BTS. Following transmission of the traffic data over the reverse link, the signal 160 reverts back to the 'control hold' state 165 following a transmission of a 'data transmission complete' state (not shown).

[0037] Although shown as a single signal 160, it should be understood that the signal may be multiple signals, optionally coded with orthogonal or non-orthogonal codes into mutually exclusive channels. For example, the 'control hold' state 165 may be transmitted on a different channel from the 'request to go active' state 170. Similarly, the traffic data transmitted in a traffic state 175 may be on a separate channel from the other two states 165, 170. An example of multiple channel is discussed in reference to Figs. 3B and 3C.

[0038] Fig. 3B is an example of an Internet code division multiple access (I-CDMA) signaling diagram that has assigned time slots for users 1, 2, 3, ..., N repeating in epoch i 177a, epoch $i+1$ 177b, and so forth. The channels are composed of the heartbeat channel 55H, request channel 55R, and traffic channels 55T. Each of these channels has an associated code C1, C2, C3, C4, ..., CN, which allow signals to be transmitted on mutually exclusive code channels. Both the transmitting and receiving systems process the information in the channels by using the codes to separate the information respectively included therein in a typical CDMA manner.

[0039] In the example shown, users 1, 2, 4, 5, 6, ..., N are requesting to remain in an idle state, indicated by the presence of a signal 180 in the heartbeat channel 55H. User 3, however, is requesting to transmit data over a reverse link based on a signal 185 in the request channel 55R in the first epoch 177a. In the second epoch 177b, user 3 begins to transmit traffic data 190 in an associated traffic channel using code C5.

[0040] Fig. 3C is a more detailed signal diagram of the 1xEV-DV signal of Fig. 3A that is used to indicate a 'request to go active' to the base station 25 from the field unit 42a. In this embodiment, the 1xEV-DV signal is composed of multiple signals on different logical channels: a heartbeat channel 55H and a request channel 55R. The heartbeat channel 55H provides continuous timing and other information (e.g., power level, synchronization, etc.) from the field unit 42a to the base station 25. The field unit 42a uses the request channel 55R to make a request (e.g., digital "1") of the base station 25 to request a traffic channel on the reverse link 65 for transmitting data.

[0041] Sampling time periods 195a, 195b, ..., 195f (collectively 195) denoted by arrows indicate times or intervals at which the BTS 25 samples the time slots of the request signal 55R and, optionally, the heartbeat channel 55H to determine whether a request for a traffic channel is being made. It should be understood that the sampling may occur over the entire time slot or a subset thereof. Also, the heartbeat channel 55H and request channel 55R use mutually exclusive codes, in this particular embodiment, so the sampling is performed on their mutually exclusive code channels 55H, 55R in all or a subset of time slots. In one particular embodiment, the base station 25 samples mutually exclusive code channels 55H, 55R in time slots designated for request indications, such as in time slots at sampling times 195b, 195d, and 195f. During these time slots, the heartbeat channel 55H is "inactive," but the request channel 55R is "active".

[0042] As discussed above, the signals in the "active" request time slots may be modulated messages or simply coded pilot signals with no "bits". Thus, detection may be based solely on the respective energy levels of the heartbeat and heartbeat-with-request signals in respective time slots over a given time interval or spanning several time intervals. In one particular embodiment, the 'control hold' state 165 indication has a first energy level, and the 'request to go active' state 170 has a second energy level.

[0043] In this particular embodiment, distinguishing the two states may be a matter of measuring energy levels of the signals(s) and (i) comparing the energy levels against at least one threshold or (ii) determining that a request is present, optionally in a mutually exclusive code channel in time slots when the heartbeat signal is at a logical zero. The different energy levels of the indications may be provided by the duty cycle of the signals, frequency of the signals, power of the signals, signaling structure, and so forth.

[0044] To understand how the energy levels of the signals can be used to improve system performance, one can refer to Fig. 4, which provides a chart for selecting signaling requirements based on the following parameters or factors: (i)

probability of detection, $P(d)$ (x-axis), (ii) signal-to-noise ratio in decibels (y-axis), and (iii) probability of false detection, $P(fd)$ (curves in the chart). This chart shows a required signal-to-noise ratio at the input terminals of a linear-rectifier detector as a function of probability of detection for a single pulse, with the false-alarm probability $P(fd)$ as a parameter, calculated for a non fluctuating signal. It should be understood that alternative parameters or factors may be used to establish or define the transmitted power levels of the indications.

[0045] At the circled point 200, the signal-to-noise ratio is 3 dB, $P(d) = 20\%$, and $P(fd) = 1\%$. To increase the probability of detection for the same probability of false detection, one simply needs to slide the circled point 200 upward along the same probability of false detection curve, which suggests that an increase in the signal-to-noise ratio is used to improve system performance and, thus, improving the likelihood that the request signal will be detected quickly.

[0046] Before providing an example model and discussion regarding example Heartbeat standby 55HS and Heartbeat Request Active 55HRA energy levels for the example communications system 100 (Fig. 1), a brief discussion of a processor and detector that may be used in the system is now provided.

[0047] Fig. 2 is a schematic diagram of a request detection processor 110 used to determine whether the field unit 42a has requested to send data to the BTS 25. The receiver Rx 35 receives signals 55, which includes the maintenance channel 55N, traffic channels 55T, access channel 55A, heartbeat standby channel 55HS, and heartbeat request active channel 55HRA. The reverse link channels 55 are processed such that a heartbeat channel processor 112 receives the heartbeat standby channel 55HS and a request channel processor 114 receives the Heartbeat Request Active channel 55HRA.

[0048] The heartbeat channel processor 112 and request channel processor 114 include the same processing elements, in this particular embodiment, so a discussion of just the heartbeat channel processor 112 will be provided for brevity.

[0049] The heartbeat channel processor 112 receives the heartbeat standby channel 55HS. A correlator 115 uses a despreader 120 to despread the heartbeat standby channel 55HS. An integrator 125 is used to coherently combine the heartbeat signal. By coherently combining the signal, an integration of I, Q and its phase causes the phase of the signal to be removed and output the power of the signal.

[0050] Following the correlator 115, a rectifier 130 (i.e., absolute value of the signal squared) rectifies the power of the signal, which is then integrated by a second integrator 135 to calculate the energy of the received heartbeat signal. The second integrator 135 provides non-coherent combination of the signal, which is calculated over short time intervals. The non-coherent integration provides just magnitudes if the terminal is moving too fast, thus causing a cross-over of the 180-degree phase point, which can cause ambiguities in determining the energy of the signal in the absence of the non-coherent combination.

[0051] The output from the heartbeat channel processor 112 is a heartbeat energy level, and the output from the request channel processor 114 is a request energy level. Each of these energy levels, in this particular embodiment, is fed to a hypothesis detector 140, which determines whether a heartbeat signal, request signal, or neither signal is in the reverse link channels 55 received by the base station 25.

[0052] To determine which signal(s) is/are present, the hypothesis detector 140 includes logical functions. For example, in this particular embodiment, the hypothesis detector 140 compares a first energy level threshold against the first energy level (i.e., heartbeat energy level) and compares a second energy level threshold against the second energy level (i.e., request energy level).

[0053] An example energy level threshold to compare the heartbeat energy level against is 9 dB and the request energy level threshold is 11 dB. The energy level thresholds may be dynamically selected, predetermined, or applied in another manner, such as based on a transmitted power level, which may be reported by the field unit to the base station over the heartbeat channel 55H, for instance. In the case of the energy level calculation and comparison, the first and second energy levels may be dependent on occupancy of time slots in the signaling channel(s) used by the signal 55, so the energy level thresholds can be based on an expected or specified number of "1" bits used to indicate a request to go active' or to indicate a request to remain in idle mode.

[0054] The output of the hypothesis detector 140 may be used to change the state of the communications system. For example, if the hypothesis detector 140 determines that a 'request to go active' (i.e., send a data transmission on the reverse link) is being made by the field unit, then the hypothesis detector outputs a signal to a processor (not shown in the BTS 25) that is responsible for providing the portable computer 12 with a traffic channel 55T. In one embodiment, the BTS 25 allocates the traffic channel 55T if the detected energy level of the signal is determined to be above the second energy level threshold. Alternatively, the BTS allocates the traffic channel 55T if the hypothesis detector 140 determines that the detected energy level is below the second energy level threshold.

[0055] As described in reference to Fig. 3C, the heartbeat channel processor 112, request channel processor 114, and hypothesis detector 140 may be configured or designed in a manner that monitors an occupancy of time slots used to indicate the request to change communications states. In one embodiments, the detecting includes monitoring occupancy of mutually exclusive code channels, such as shown in Figs. 3B and 3C.

[0056] A feedback loop (not shown) may be employed to cause the heartbeat channel processor 112 and request

channel processor 114 to be "adaptive". For example, based on the received energy level of the heartbeat channel 55H, the integration time of the integrators 125, 135 may be adjusted, and the energy level thresholds used by the hypothesis detector 140 for comparison of the energy levels of the heartbeat and request signals may also be adjusted by the feedback loop. Such a feedback loop may use a command or message to transfer information between the BTS and field unit that includes information regarding the power levels of the heartbeat or heartbeat-with-request signals transmitted by the field unit.

[0057] As discussed above, the first communications state may be a standby communications state and the second communications state may be a payload communications state. In other systems or even the same system, the communications states may refer to other communications states, such as a request to change base stations, power control signaling, and so forth. The use of different energy levels in signaling as described herein is applicable to wireless, wired, or optical communications systems. In either case, the communications states may be used in voice or data communications systems.

[0058] As also discussed above, the second energy level may be based on a target probability of detection, false detection, or combination of both as discussed in reference to Fig. 4. In other words, the field unit may transmit the request signal at a given power level or a given number of pulses per given time period to achieve a corresponding signal-to-noise ratio for a given target probability of detection, false detection, or both as discussed in reference to Fig. 4.

[0059] An analysis may be used to set the transmission power or number of transmitted indications, or a feedback mechanism may be employed in the communication system for causing the field unit to change its behavior so as to have the received energy levels of the indications achieve a predetermined signal-to-noise ratio, thus providing the desired probability of detection and false detection parameters.

SIMULATION:

[0060] A simulation is now presented that discusses the trades effecting the probabilities of detection and false detection for the heartbeat (HB) and heartbeat-with-request (HB/RQST) channels. Recommended SNR targets for HB and HB/RQST channels are provided. Further, an analytical calculation is made to determine a recommended target E/I_o for an acceptable probability of detection and probability of false detection.

[0061] To allow readers to baseline the simulation relative to IS-2000 power control, the reader should be aware that the simulation employs the following parameters:

800Hz closed loop power control;

SNR of the i'th user is calculated as $SNR(i) = P(i) - P_{interference} + \text{processing Gain} + E_r$, where $P_{interference}(i)$ is a total received interference for the i'th user and calculated as $P_{interference}(i) = 20 \cdot \log_{10}(10^{\sum_{j \neq i} P(j)/20} + 10^{P_{TH}/20})$, where $P(i)$ is the power received from the i'th user and P_{TH} is thermal noise floor and is arbitrarily set to 120 dBm;

processing gain is $10 \log_{10} 64$;

fading model is Jakes;

E_r = a Normal distributed random variable with 1 sigma = 0.67 dB error in SNR estimation at the BTS; and power control bit (PCB) errors = 3%.

[0062] In this particular simulation, a choice of a target SNR for the HB channel was chosen first. Based on a 9 dB E/I_o, where E is the entire energy in the heartbeat message and a 95% probability of detection with a 0.1% false detection rate in Additive White Gaussian Noise (AWG) is achieved (see Viterbi, A., CDMA: Principles of Spread Spectrum Communication, Addison Wesley, 1995, p113.)

[0063] Increasing the probability of detection to 99% yields significantly higher false detection rate of 1% in AWGN. This false detection rate is of interest as it should be low enough that non-detection will occur for a relatively long duration when the terminal has dropped the communications link with the base station.

[0064] Typically, the duration is defined by a timer having a duration of 500ms to 2 sec or 25 to 100 sequential non-detections. For reference, in a single path fading environment with 9 dB E/I_o, a 90% detection probability and a 1% false detection rate is predicted by theory. For this case, the details associated with the detection probability in the fading environment are considered in the following discussion.

[0065] Detection of the heartbeat signal with 50 Hz power control versus field unit velocity is now considered. The simulation is based on a full rate model in which modifications were made such that the power control (PC) rate is 50 Hz and standby terminals are time slotted, non-overlapping.

[0066] While the speed of the terminal is irrelevant above about 2 mph, closed-loop power control is seen as useful in allowing the fading to vary around the mean path loss. It is noted that the results are relatively insensitive to a Power Control Bit (PCB) error rate up to about 40%. Beyond that, the system performed poorly, demonstrating that some form of closed-loop control is needed to maintain the mean path loss. It is therefore useful that some form of closed-loop

power control be performed to bring the transmitter (Tx) power of the field unit to the average appropriate for the field unit to achieve the mean path loss to the base station.

[0067] Simulation using the above parameters shows that if the base station detects the 'request to go active' indication 2 dB below the target SNR (as defined above), then the average time of detection is about 16 ms, with standard deviation at about 14 ms. From the simulation, to achieve a low latency in HB/RQST detection, the following equation has been determined:

$$\text{Target_SNR(RQST)} = \text{Target_SNR(HB)} + 2 \text{ dB} \quad (1)$$

[0068] Based on the required detecting/false detection rates in AWGN, a Target_SNR of 9 dB for the Heartbeat message and 11 dB for the heartbeat-with-request (HB/RQST) message were chosen. These parameters yield a 15 ms detection latency on average at 20 mph with low probability of false detection.

[0069] In terms of false assignment probability, while the false detection rate is not explicitly calculated in the simulation, a pessimistic bound is given as follows:

$$\begin{aligned} \text{Pfd(RQST)} &= (1 - \text{Pd(HB)}) * \text{Pfd(HB)} & (2) \\ &= 5\% * 0.1\% = 5E-5, \end{aligned}$$

where Pfd is the probability of false detection and Pd is the probability of detection.

[0070] The above equation and result is a product of two conditions: (i) not detecting the existence of a HB while it is present and (ii) falsely detecting a HB when it is not present. This is a pessimistic bound since the additional 2 dB of transmitted power for HB/RQST versus HB is not included in the analysis.

[0071] At a HB rate of 50 Hz, this would yield a false assignment for one standby user every 400 seconds on average. For N heartbeat users, the probability is linear since the events are independent. Therefore; for a fully loaded standby user population of 96 for a particular base station, the average false assignment rate is expected to be roughly one every four seconds.

[0072] A condition of a false assignment can be recovered from relatively quickly as the false assignment can be detected quickly. When a false assignment occurs, three conditions are typically present. First, no traffic shows up on the assigned reverse channel. Second, the heartbeat- with-request signal is not present. If a missed channel assignment has occurred, the HB/RQST continues to be present. Third, the heartbeat message will likely be present. The probability of not detecting this condition in one frame is $\text{Pfd(RQST)} = 5E-3\%$. This should be detected within one or two frames before the channel can be re-assigned to a legitimate user. If it is assumed that detection takes two frames, the reverse capacity would be reduced by no more than 1% and is likely less as the probability of false detection for the HB/RQST is targeted at 11 dB E/lo.

[0073] For a signal with no offset between the Target_SNR and the detection threshold, the delay to detection is 35 ms on the average between the simulation with a remote subscriber unit moving at 1 mph and at 20 mph. For the heartbeat-with-request (HB/RQST) signal, the average delay to detection is less than 20ms, with a detection threshold of 2 dB below the target SNR of 11 dB. This is possible since the transmit (Tx) power is increased by 2 dB for the HB/RQST relative to the HB signal.

[0074] The simulation shows that the minimum average, given 96 users in a 20 ms power control (PC) period is close to 10ms. The delay is expected to be better than 75ms 99% of the time.

[0075] The simulation also shows that the addition of 2 dB of additional transmit power for the HB/RQST message increases the detection probability and reduces the detection latency to 15ms on average. An estimate of the co-channel total interference of a fully loaded maintenance channel is between 6 dB less than an IS-2000 fundamental channel (9600 bps Reverse Traffic Channel (R-TCH), 9600 bps Reverse Dedicated Control Channel (R-DCCH)).

[0076] While this invention has been particularly shown and described with references to preferred embodiments thereof, it will be understood by those skilled in the art that various changes in form and details may be made therein without departing from the scope of the invention encompassed by the appended claims.

Claims

1. A method in a field unit (42) for dynamic traffic channel allocation comprising:

- transmitting a marker signal in an assigned time slot, the method **characterised in:**

- **that** the marker signal indicates that the field unit (42) is to go active and requests the assignment of traffic channels for data transmission from the field unit (42) to a base station (25), wherein different markers are indicated by transmission at different power levels, wherein a non-request signal type is transmitted at a first power level and a request signal type is transmitted at a second power level.

2. A method according to claim 1, wherein the marker signal is transmitted in an assigned time slot to indicate said request.

3. A method according to claim 1 or 2, wherein the field unit (42) selects different marker signals depending on a needed communications state.

4. A method according to claim 3, wherein different marker signals are associated with different energy levels.

5. A method according to claim 4, wherein the energy levels are selected based on a target probability of detection.

6. A method according to claim 3, wherein different marker signals are associated with different time slots.

7. A method according to claim 3, wherein different marker signals are associated with different numbers of repetitions.

8. A method according to claim 3, wherein different marker signals are associated with different code channels.

9. A method according to any of claims 3-8, wherein marker signals are multiplexed on a signaling channel.

10. A method according to any of the preceding claims, wherein the field unit (42) operates in a code division multiple access, CDMA, or orthogonal frequency division multiplexing, OFDM, wireless communications system (100).

11. A field unit (42) comprising means for carrying out the method according to any of claims 1-10.

12. A method in a wireless communications system (100) for dynamic traffic allocation, the method **characterised by:**

- receiving a marker signal from a field unit (42) in an assigned time slot; and

- determining that the marker signal indicates that the field unit is to go active and requests the assignment of traffic channels for data transmission from the field unit to a base station, wherein different markers are indicated by transmission at different power levels, wherein a non-request signal type is transmitted at a first power level and a request signal type is transmitted at a second power level.

13. A method according to claim 12, wherein the determining is based on the marker signals being transmitted in an assigned time slot to indicate said request.

14. A method according to claim 12 or 13, wherein the different marker signals correspond to different communications states needed by the field unit (42).

15. A method according to claim 14, wherein the determining is based on the different marker signals being associated with different energy levels.

16. A method according to claim 14, wherein the determining is based on different marker signals being associated with different time slots.

17. A method according to claim 14, wherein the determining is based on different marker signals being associated with different numbers of repetitions.

18. A method according to claim 14, wherein the determining is based on different marker signals being associated with different code channels.

19. A method according to any of claims 14-18, wherein marker signals are multiplexed on a signaling channel.

20. A method according to any of the preceding claims, wherein the node operates in a code division multiple access, CDMA, or orthogonal frequency division multiplexing, OFDM, wireless communications system (100).

5 21. A node in a wireless communications system (100) comprising means for carrying out the method according to any of claims 12-20.

Patentansprüche

10 1. Verfahren für eine dynamische Netzverkehrskanalzuteilung in einer Feldeinheit (42), umfassend:

- Übertragen eines Markierungssignals in einem zugewiesenen Zeitschlitz, wobei das Verfahren **dadurch gekennzeichnet ist**,

15 - **dass** das Markierungssignal anzeigt, dass die Feldeinheit (42) aktiv wird und die Zuteilung von Netzverkehrskanälen für eine Datenübertragung von der Feldeinheit (42) zu einer Basisstation (25) anfordert, wobei verschiedene Markierungen durch Übertragungen auf unterschiedlichen Leistungspegeln angezeigt werden, wobei ein Nicht-Anforderungssignaltyp auf einem ersten Leistungspegel übertragen wird und ein Anforderungssignaltyp auf einem zweiten Leistungspegel übertragen wird.

20 2. Verfahren nach Anspruch 1, wobei das Markierungssignal in einem zugewiesenen Zeitschlitz übertragen wird, um die Anforderung anzuzeigen.

25 3. Verfahren nach Anspruch 1 oder 2, wobei die Feldeinheit (42) abhängig von einem erforderlichen Kommunikationszustand unterschiedliche Markierungssignale auswählt.

30 4. Verfahren nach Anspruch 3, wobei verschiedene Markierungssignale unterschiedlichen Energiepegeln zugeordnet werden.

35 5. Verfahren nach Anspruch 4, wobei die Energiepegel aufgrund einer Zielerkennungswahrscheinlichkeit ausgewählt werden.

40 6. Verfahren nach Anspruch 3, wobei verschiedene Markierungssignale unterschiedlichen Zeitschlitzern zugeordnet werden.

45 7. Verfahren nach Anspruch 3, wobei verschiedenen Markierungssignalen unterschiedliche Anzahlen von Wiederholungen zugeordnet werden.

50 8. Verfahren nach Anspruch 3, wobei verschiedene Markierungssignale unterschiedlichen Codekanälen zugeordnet werden.

55 9. Verfahren nach einem der Ansprüche 3 bis 8, wobei die Markierungssignale in einem Signalisierungskanal gemultiplext werden.

10. Verfahren nach einem der vorhergehenden Ansprüche, wobei die Feldeinheit (42) in einem drahtlosen Kommunikationssystem (100) mit einem Codemultiplexverfahren (Code Division Multiple Access, CDMA) oder mit einem orthogonalen Frequenzmultiplexverfahren (Orthogonal Frequency Division Multiplexing, OFDM) betrieben wird.

11. Feldeinheit (42), die ein Element zum Ausführen des Verfahrens nach einem der Ansprüche 1 bis 10 umfasst.

50 12. Verfahren für eine dynamische Netzverkehrskanalzuteilung in einem drahtlosen Kommunikationssystem (100), wobei das Verfahren **gekennzeichnet ist durch**:

- Empfangen eines Markierungssignals von einer Feldeinheit (42) in einem zugewiesenen Zeitschlitz; und
- Ermitteln, dass das Markierungssignal anzeigt, dass die Feldeinheit aktiv wird und die Zuteilung von Netzverkehrskanälen für eine Datenübertragung von der Feldeinheit zu einer Basisstation anfordert, wobei verschiedene Markierungen **durch** Übertragungen auf unterschiedlichen Leistungspegeln angezeigt werden, wobei ein Nicht-Anforderungssignaltyp auf einem ersten Leistungspegel übertragen wird und ein Anforderungssignaltyp auf einem zweiten Leistungspegel übertragen wird.

EP 2 479 903 B1

13. Verfahren nach Anspruch 12, wobei das Ermitteln darauf beruht, dass das Markierungssignal in einem zugewiesenen Zeitschlitz übertragen wird, um die Anforderung anzuzeigen.
- 5 14. Verfahren nach Anspruch 12 oder 13, wobei die verschiedenen Markierungssignale unterschiedlichen von der Feldeinheit (42) benötigten Kommunikationszuständen entsprechen.
15. Verfahren nach Anspruch 14, wobei das Ermitteln darauf beruht, dass die verschiedenen Markierungssignale unterschiedlichen Energiepegeln zugeordnet werden.
- 10 16. Verfahren nach Anspruch 14, wobei das Ermitteln darauf beruht, dass die verschiedenen Markierungssignale unterschiedlichen Zeitschlitzern zugeordnet werden.
17. Verfahren nach Anspruch 14, wobei das Ermitteln darauf beruht, dass den verschiedenen Markierungssignalen unterschiedliche Anzahlen von Wiederholungen zugeordnet werden.
- 15 18. Verfahren nach Anspruch 14, wobei das Ermitteln darauf beruht, dass die verschiedenen Markierungssignale unterschiedlichen Codekanälen zugeordnet werden.
- 20 19. Verfahren nach einem der Ansprüche 14 bis 18, wobei die Markierungssignale in einem Signalisierungskanal gemultiplext werden.
20. Verfahren nach einem der vorhergehenden Ansprüche, wobei der Knoten in einem drahtlosen Kommunikationssystem (100) mit einem Codemultiplexverfahren (Code Division Multiple Access, CDMA) oder mit einem orthogonalen Frequenzmultiplexverfahren (Orthogonal Frequency Division Multiplexing, OFDM) betrieben wird.
- 25 21. Knoten in einem drahtlosen Kommunikationssystem (100), der ein Element zum Ausführen des Verfahrens nach einem der Ansprüche 12 bis 20 umfasst.

30 **Revendications**

1. Procédé dans une unité de terrain (42) pour une attribution dynamique de canaux de trafic comprenant :
- 35 - la transmission d'un signal marqueur dans un intervalle de temps attribué, le procédé étant **caractérisé en ce** :
- **que** le signal marqueur indique que l'unité de terrain (42) doit devenir active et demande l'attribution de canaux de trafic pour une transmission de données à partir de l'unité de terrain (42) vers une station de base (25), cas dans lequel différents marqueurs sont indiqués par une transmission à différents niveaux de puissance, cas dans lequel un type de signal de non demande est transmis à un premier niveau de puissance et un type de signal de demande est transmis à un deuxième niveau de puissance.
- 40 2. Procédé selon la revendication 1, le signal marqueur étant transmis dans un intervalle de temps attribué afin d'indiquer ladite demande.
- 45 3. Procédé selon la revendication 1 ou 2, l'unité de terrain (42) sélectionnant différents signaux marqueurs en dépendance d'un état de communications requis.
4. Procédé selon la revendication 3, différents signaux marqueurs étant associés à différents niveaux d'énergie.
- 50 5. Procédé selon la revendication 4, les niveaux d'énergie étant sélectionnés sur la base d'une probabilité cible de détection.
6. Procédé selon la revendication 3, différents signaux marqueurs étant associés à différents intervalles de temps.
- 55 7. Procédé selon la revendication 3, différents signaux marqueurs étant associés à différents nombres de répétitions.
8. Procédé selon la revendication 3, différents signaux marqueurs étant associés à différents canaux de code.

EP 2 479 903 B1

9. Procédé selon l'une quelconque des revendications 3 à 8, différents signaux marqueurs étant multiplexés sur un canal de signalisation.
- 5 10. Procédé selon l'une quelconque des revendications précédentes, l'unité de terrain (42) opérant dans un système de communications sans fil (100) à accès multiple par répartition en code, CDMA, ou à multiplexage par répartition orthogonale de la fréquence, OFDM.
- 10 11. Unité de terrain (42) comprenant des moyens destinés à réaliser le procédé conformément à l'une quelconque des revendications 1 à 10.
12. Procédé dans un système de communications sans fil (100) pour une attribution dynamique du trafic, le procédé étant **caractérisé par** les opérations consistant à :
- 15 - recevoir un signal marqueur en provenance d'une unité de terrain (42) dans un intervalle de temps attribué ; et
- déterminer que le signal marqueur indique que l'unité de terrain doit devenir active et demande l'attribution de canaux de trafic pour une transmission de données à partir de l'unité de terrain vers une station de base, cas dans lequel différents marqueurs sont indiqués par une transmission à différents niveaux de puissance, cas dans lequel un type de signal de non demande est transmis à un premier niveau de puissance et un type de signal de demande est transmis à un deuxième niveau de puissance.
- 20 13. Procédé selon la revendication 12, la détermination étant basée sur le fait que les signaux marqueurs sont transmis dans un intervalle de temps attribué afin d'indiquer ladite demande.
- 25 14. Procédé selon la revendication 12 ou 13, les différents signaux marqueurs correspondant à différents états de communications requis par l'unité de terrain (42).
15. Procédé selon la revendication 14, la détermination étant basée sur le fait que les différents signaux marqueurs sont associés à différents niveaux d'énergie.
- 30 16. Procédé selon la revendication 14, la détermination étant basée sur le fait que différents signaux marqueurs sont associés à différents intervalles de temps.
17. Procédé selon la revendication 14, la détermination étant basée sur le fait que différents signaux marqueurs sont associés à différents nombres de répétitions
- 35 18. Procédé selon la revendication 14, la détermination étant basée sur le fait que différents signaux marqueurs sont associés à différents canaux de code.
19. Procédé selon l'une quelconque des revendications 14 à 18, des signaux marqueurs étant multiplexés sur un canal de signalisation.
- 40 20. Procédé selon l'une quelconque des revendications précédentes, le noeud opérant dans un système de communications sans fil (100) à accès multiple par répartition en code, CDMA, ou à multiplexage par répartition orthogonale de la fréquence, OFDM.
- 45 21. Noeud dans un système de communications sans fil (100) comprenant des moyens destinés à réaliser le procédé conformément à l'une quelconque des revendications 12 à 20.
- 50
- 55

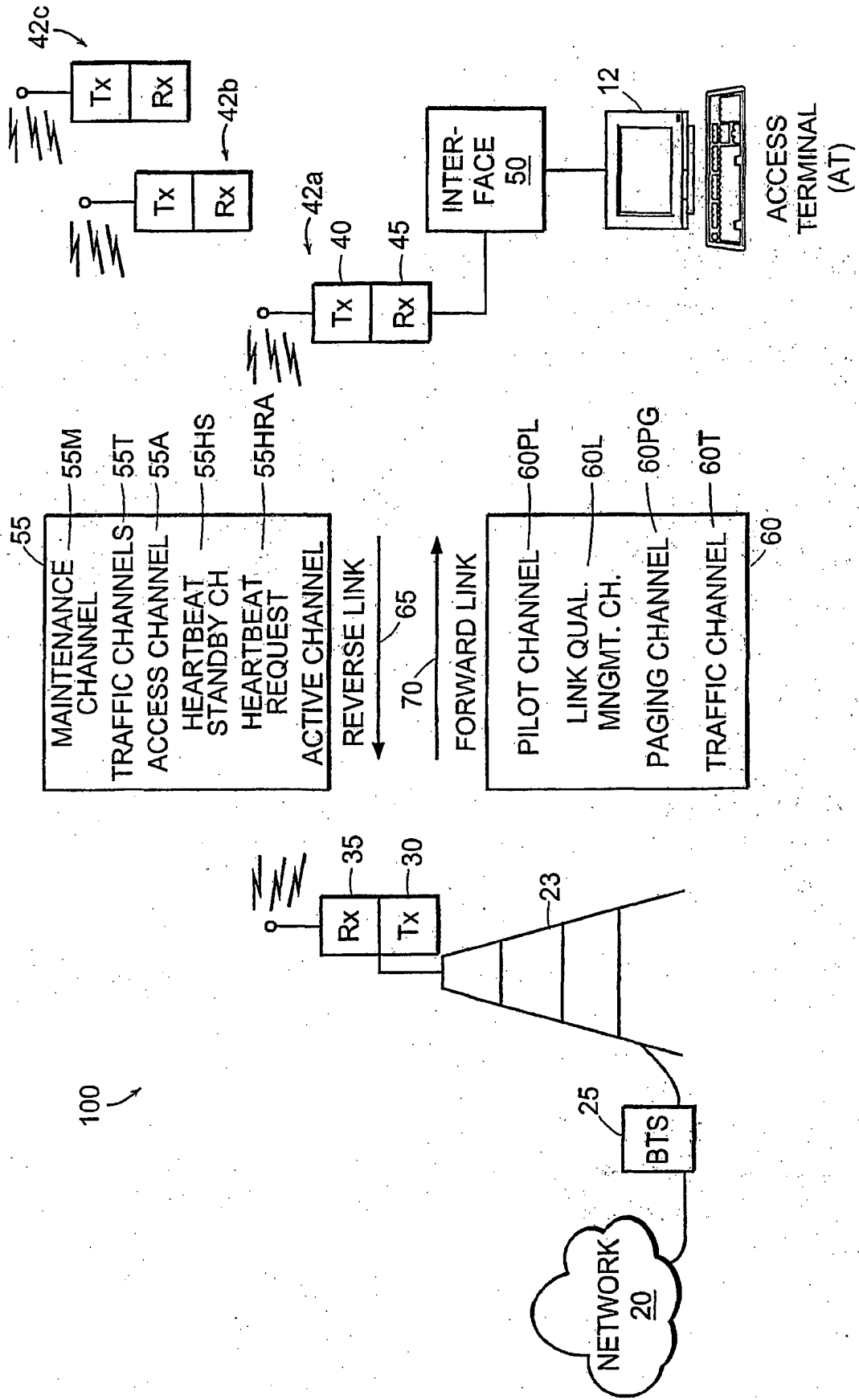

FIG. 1

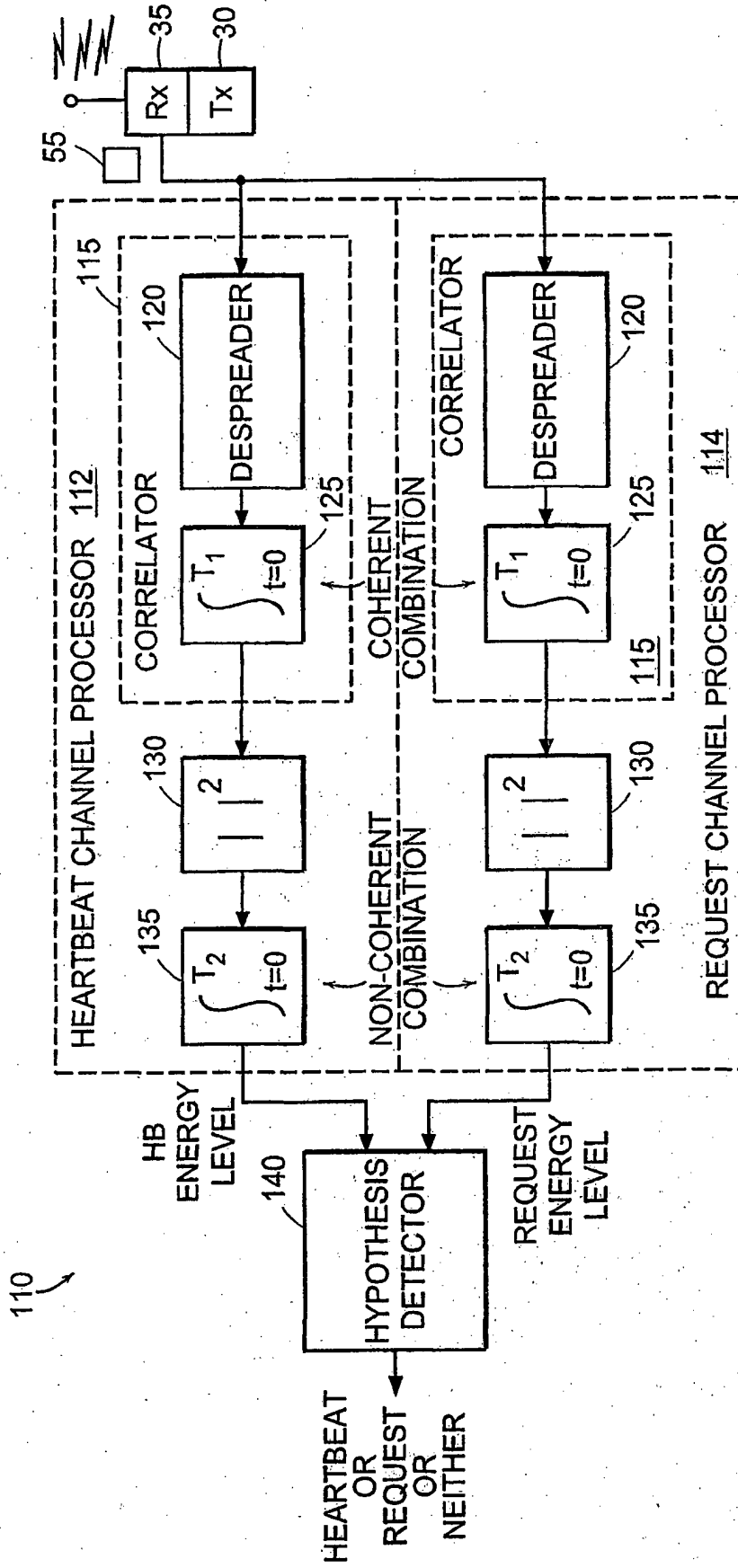

FIG. 2

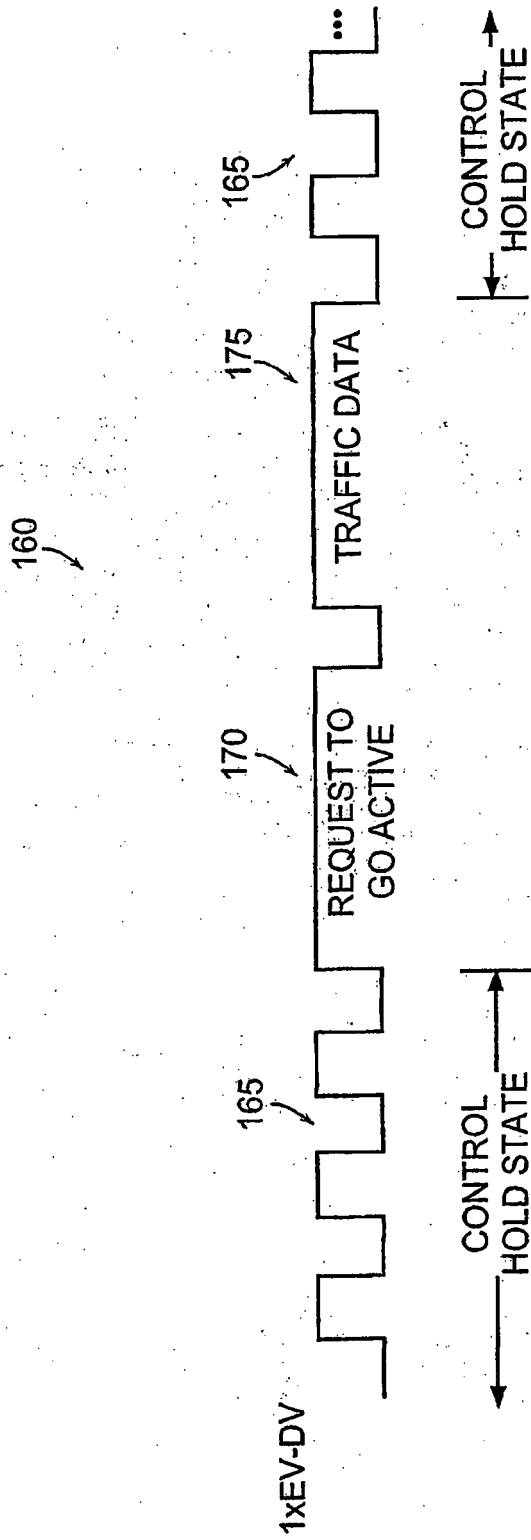

FIG. 3A

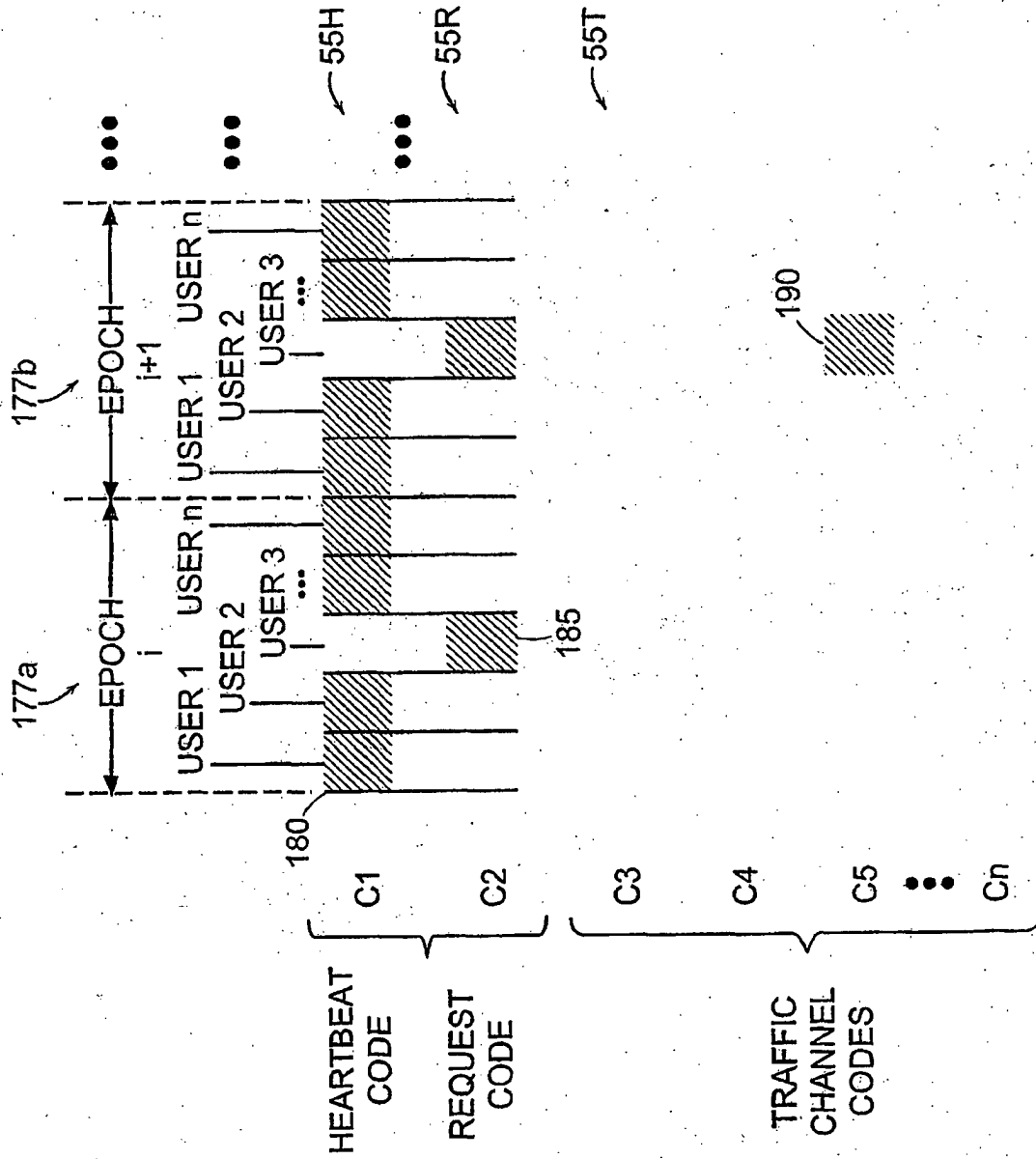

FIG. 3B

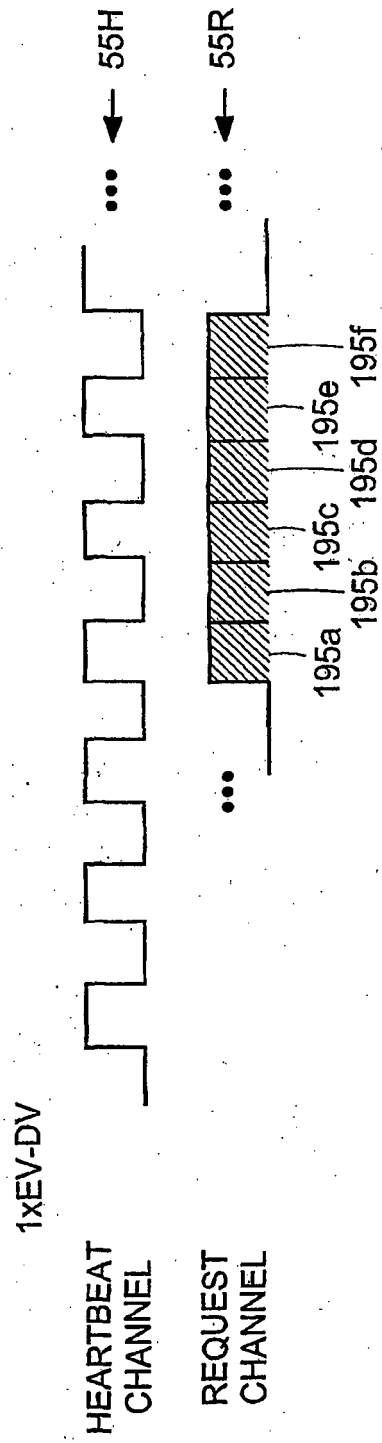

FIG. 3C

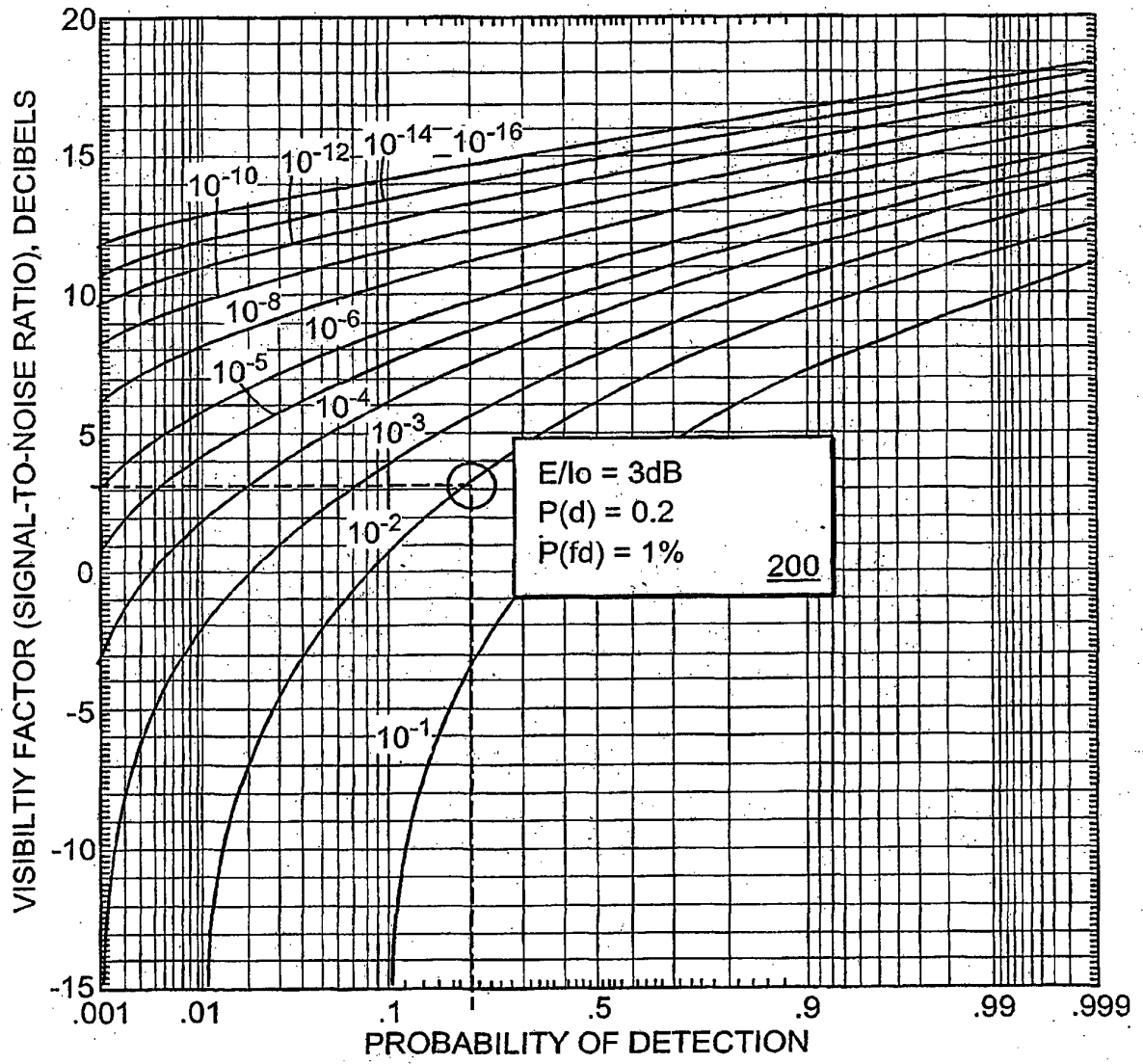

FIG. 4

REFERENCES CITED IN THE DESCRIPTION

This list of references cited by the applicant is for the reader's convenience only. It does not form part of the European patent document. Even though great care has been taken in compiling the references, errors or omissions cannot be excluded and the EPO disclaims all liability in this regard.

Patent documents cited in the description

- WO 9749201 A [0011]
- WO 9963682 A [0012]
- WO 0057663 A [0013]
- EP 0475698 A [0014]
- US 09775305 B [0021]