

E. E. QUAINANCE.  
 PERMUTATION LOCK.  
 APPLICATION FILED JAN. 4, 1911.

1,017,313.

Patented Feb. 13, 1912.

3 SHEETS—SHEET 1.

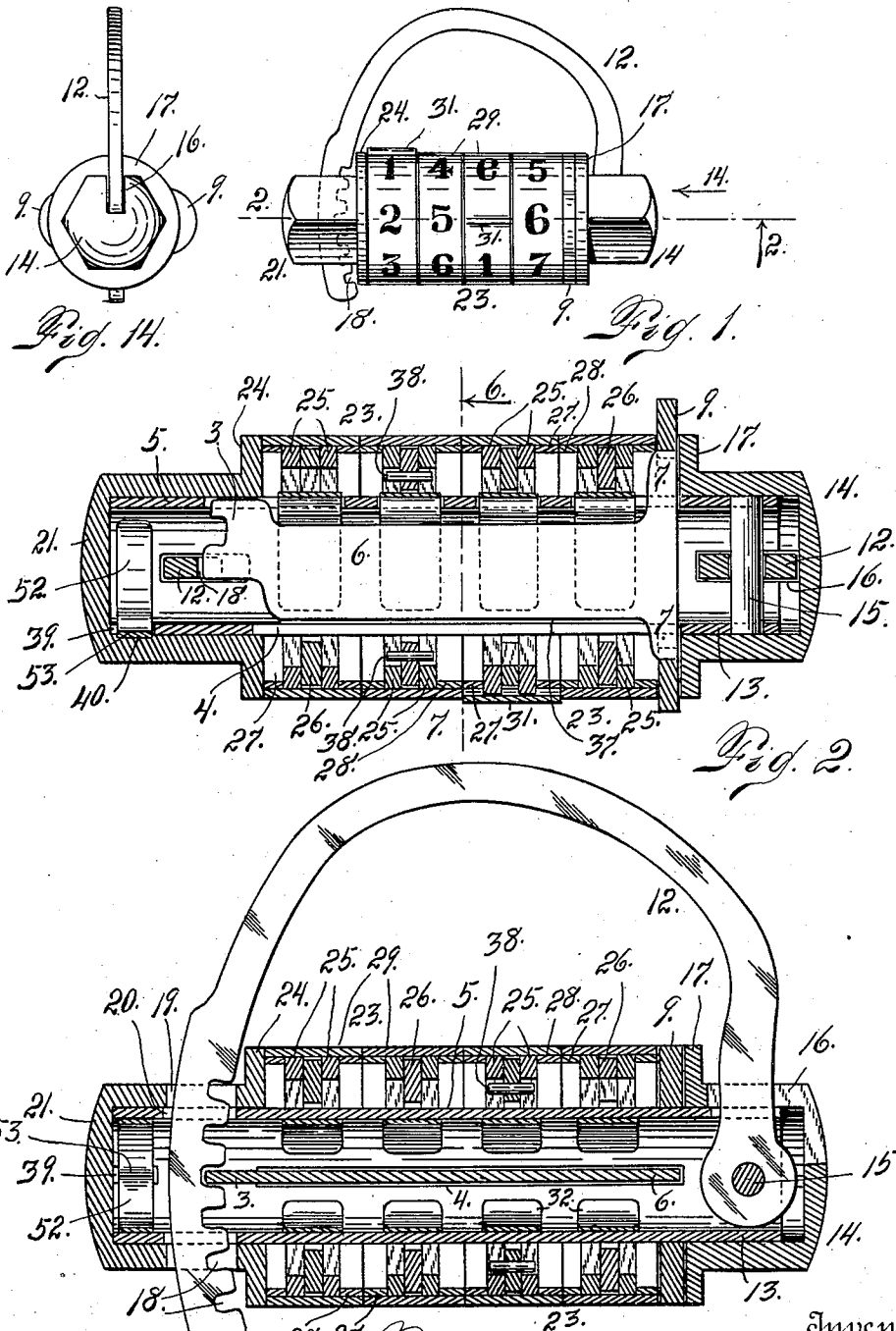

Witnesses  
*Otto O. Hordlick*  
*C. H. Rossmor*

*28. 27. Fig. 3.*

Inventor  
*E. E. Quaintance*  
 By *B. J. O'Brien*  
 Attorney

E. E. QUAINANCE.  
 PERMUTATION LOCK.  
 APPLICATION FILED JAN. 4, 1911.

1,017,313.

Patented Feb. 13, 1912.

3 SHEETS—SHEET 2.

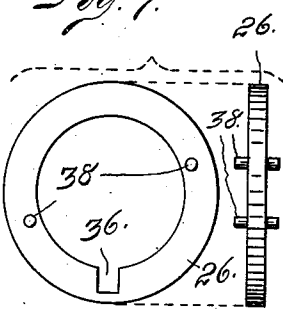
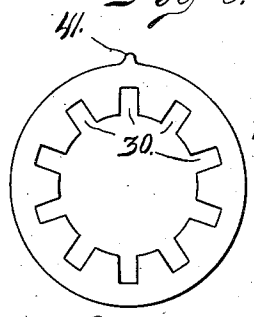
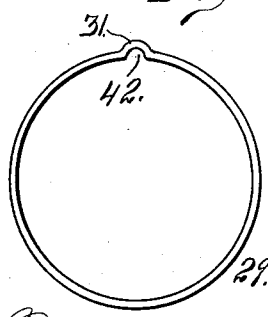
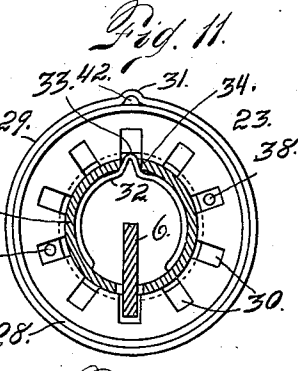
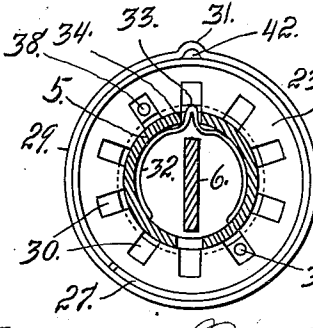
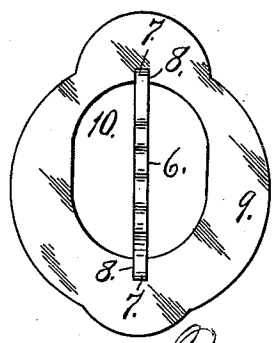
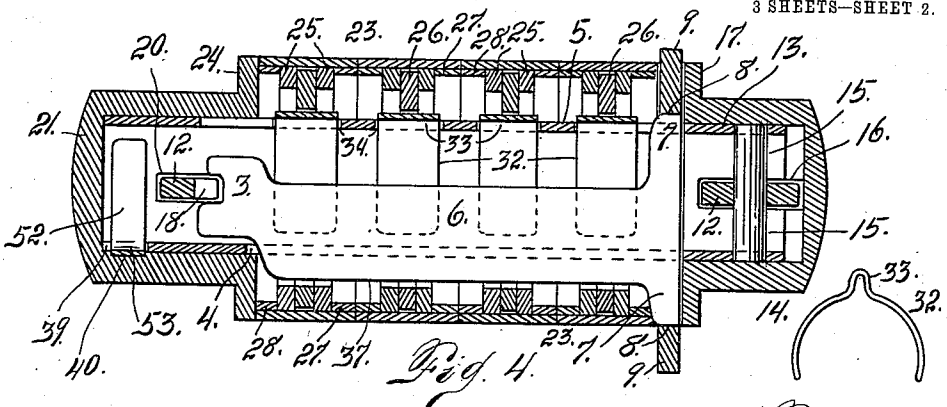

Fig. 8.

Fig. 9.

Fig. 10.

Fig. 12.

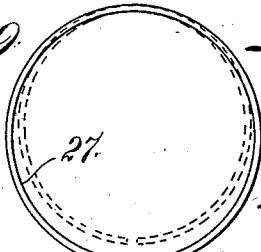
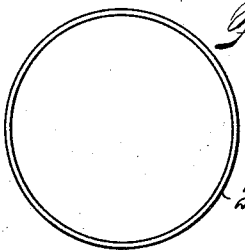

Fig. 13.

Witnesses  
*Otto E. Huddick.*  
*C. H. Rossmor.*

Inventor  
*E. E. Quainance*  
 By *C. J. O'Brien.*  
 Attorney

E. E. QUAINANCE.  
 PERMUTATION LOCK.  
 APPLICATION FILED JAN. 4, 1911.

1,017,313.

Patented Feb. 13, 1912.

3 SHEETS—SHEET 3.

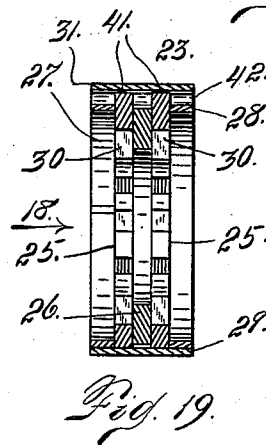
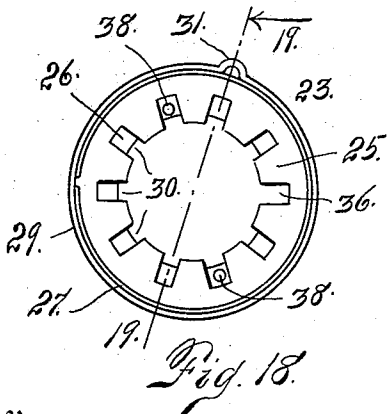
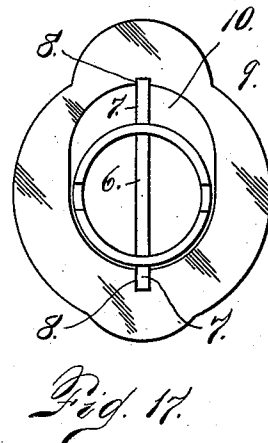
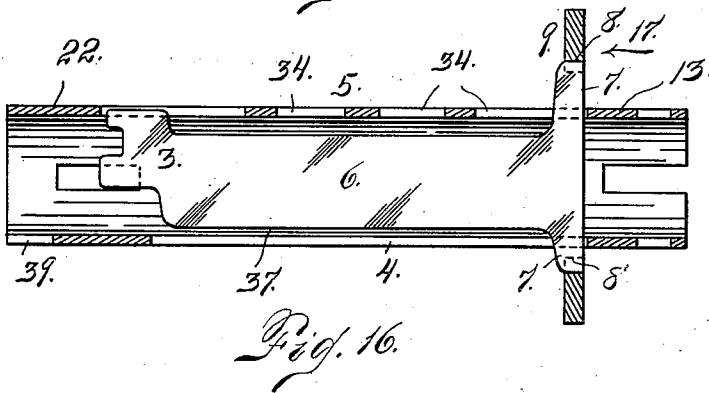
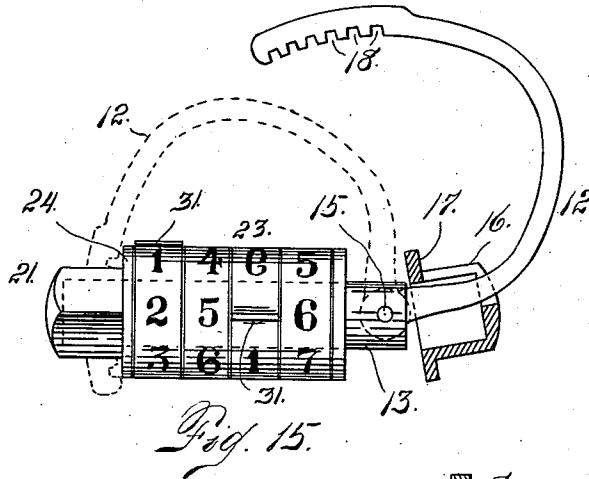

Witnesses  
*Otto E. Haddick.*  
*C. H. Rossner.*

Inventor  
*E. E. Quainance.*  
 By *B. J.'Brien.*  
 Attorney

# UNITED STATES PATENT OFFICE.

ELLSWORTH E. QUAINANCE, OF DENVER, COLORADO.

## PERMUTATION-LOCK.

1,017,313.

Specification of Letters Patent.

Patented Feb. 13, 1912.

Application filed January 4, 1911. Serial No. 600,839.

*To all whom it may concern:*

Be it known that I, ELLSWORTH E. QUAINANCE, a citizen of the United States, residing in the city and county of Denver and State of Colorado, have invented certain new and useful Improvements in Permutation-Locks; and I do declare the following to be a full, clear, and exact description of the invention, such as will enable others skilled in the art to which it appertains to make and use the same, reference being had to the accompanying drawings, and to the characters of reference marked thereon, which form a part of this specification.

My invention relates to improvements in permutation locks.

In the drawing my improved lock is illustrated as a padlock, or a lock adapted to be employed as a handcuff. In the handcuff form a shackle is employed similar to a padlock, but the shackle is adjustable to adapt it for use with persons having hands of varying size.

In my improved construction of lock I employ a tubular cylinder in which is located what I term a pallet, consisting of a plate which is laterally movable into and out of engagement with recesses formed in tumblers rotatably mounted upon the cylinder, the construction being such that when the combination is solved the open slots of all the tumblers are in longitudinal alinement and in position to allow the pallet to be moved into engagement with the slots, one edge of the pallet entering the alined slots of all the tumblers. This movement of the pallet is sufficient to bring the recess in one of its extremities into alinement with the opening in the end of the cylinder and lock casing, whereby the shackle may be disengaged from the pallet. In order to move the pallet into position to retain the shackle, it is only necessary to move it laterally sufficiently to disengage it from the recesses of the tumblers, after which the movement of one of these tumblers will throw its open slot out of line with the slots of the other tumblers, thus retaining the pallet in such position. In this event the recess in the end of the pallet is out of alinement with the opening in the cylinder and lock casing, and the adjacent part of the pallet is caused to enter a notch in the end of the shackle, thus preventing the withdrawal of the latter from the lock casing.

My improved construction also includes caps adapted to fit over the opposite extremities of the cylinder, which protrude beyond the tumbler portion of the lock. These caps are secured against removal when the shackle is in the locking position. When, however, the shackle is unlocked either cap may be disengaged from the cylinder. The cap at the extremity of the lock which the free end of the shackle enters may be disengaged from the cylinder by giving it a partial turn, whereby a spring located within the adjacent extremity of the cylinder is disengaged from a recess in the cap. The latter may then be removed from the cylinder by a pull in a direction corresponding with the axis of the lock. On the contrary the opposite cap cannot be disengaged from the cylinder until the shackle is thrown open far enough to allow the cap as it is slipped from the cylinder, to move outwardly into a position whereby the shackle is threaded therethrough, the cap having an opening for the purpose. When this is done the pivot pin which retains the shackle in place, and both extremities of which are normally concealed by the cap, may be removed for the purpose of detaching the shackle from the lock.

The tumblers are exteriorly provided with characters, as numerals, which occupy positions corresponding to the various recesses or slots of the tumbler members having a series of such recesses, and each tumbler may have its parts so assembled that its open slot or recess may be directly opposite any figure formed on the exterior shell of the tumbler from 1 to 0. It may be mentioned, however, that instead of using the zero character I prefer to form a slight protuberance upon the tumbler for convenience in operating the lock in the dark, since this protuberance being located in the zero position enables the operator to know how far to turn the tumbler in order to bring the desired character thereon into the proper position to solve the combination, as each movement of the tumbler for a distance equal to the space between two figures or characters, is attended by an audible click and by counting these clicks the operator will know when the proper numeral is brought into the desired position.

Having briefly outlined my improved construction, I will proceed to describe the same in detail, reference being made to the ac-

companion drawing in which is illustrated an embodiment thereof.

In this drawing: Figure 1 is an elevation of my improved lock. Fig. 2 is a longitudinal section taken on the line 2—2, Fig. 1, the parts being shown on a larger scale, the pallet being shown in position to lock the shackle against withdrawal. Fig. 3 is a section taken at right angles to Fig. 2. Fig. 4 is a section similar to Fig. 2, but showing the pallet in the unlocked position. Fig. 5 is an end detail elevation of the pallet shown in connection with the disk to which it is attached. Fig. 6 is a section taken on the line 6—7, Fig. 2. Fig. 7 is a section taken on the same line, but showing the pallet in the unlocked position. Fig. 8 is a detail view of the exterior shell of one of the tumblers. Fig. 9 is a similar view of one of the tumbler members containing a series of radially arranged recesses. Fig. 10 is a view illustrating a tumbler member shown in two positions. This is the member which is located intermediate two members identical with Fig. 9. Fig. 11 is a detail view of a click spring employed in connection with the lock. Fig. 12 is a detail view of a stop ring constituting a tumbler member. Fig. 13 is a similar view of an open spring ring also constituting a part of each tumbler. Fig. 14 is an end elevation of the lock, looking in the direction of arrow 14, Fig. 1. Fig. 15 is a view similar to Fig. 1, the shackle, however, being shown in two positions, one in full lines and the other in dotted line. In the full line position the shackle is open to its limit of movement. Fig. 16 is a sectional view of the cylinder shown in connection with the pallet, the latter being illustrated in side elevation. Fig. 17 is an end elevation of the same, being a view looking in the direction of arrow 17, Fig. 16. Fig. 18 is an end elevation of one of the tumblers, looking in the direction of arrow 18, Fig. 19. Fig. 19 is a section taken on a plane cutting the axis of a tumbler, or a view on the line 19—19, Fig. 18.

The same reference characters indicate the same parts in all the views.

Let the numeral 5 designate the cylinder or hollow spindle of my improved lock, in which is located the pallet 6 which consists of a flat plate having projections 7 at one extremity, which protrude through the shell of the cylinder and enter recesses 8 formed in a disk 9 having an elongated opening 10 through which the cylinder passes, the said opening in its lengthwise direction being enough larger than the diameter of the cylinder to allow the disk and pallet sufficient lateral movement for locking and unlocking the shackle 12, one extremity of which is pivotally connected with the extremity 13 of the cylinder beyond the pallet disk 9 by a pin 15. When the parts are assembled a

cap 14 engages the extremity 13 of the cylinder, fits closely against the pallet disk 9 and conceals both extremities of the pin 15, to prevent tampering with the lock by the removal of the pin when the shackle is in the locked position. This cap 14 is, of course, hollow to receive the cylinder extremity and it is slotted as shown at 16, from its flange 17, and extending to the center of the outer extremity thereof to allow the shackle to be moved to the position shown in full lines in Fig. 15, to allow the cap to be disengaged from the cylinder while the shackle is still connected therewith by the pin 15. The opposite extremity of the shackle, or that adapted to interlock with the pallet, is provided with a series of recesses 18. This extremity is adapted to enter registering openings 19 and 20 formed in opposite sides of an end cap 21 and the adjacent extremity 22 of the cylinder. The extremity 3 of the pallet is adapted to interlock with either recess 18 of the shackle for the purpose of preventing the withdrawal of the latter or retaining it in the locked position.

The tumblers, each of which will be designated in its entirety by the numeral 23, as illustrated in the drawing are four in number, the same being mounted on the cylinder 5 between the flange 24 of the cylinder cap 21 and the pallet disk 9, located at the opposite extremity of the cylinder and in contact with the flange of the adjacent cylinder cap 14. Each of these tumblers is composed of two members 25, an intermediate member 26, an open ring 27 and a continuous ring 28, the members 25, 25, 26, 27 and 28 all being inserted in a shell 29. Each of the members 25 is provided with a series of radially arranged recesses 30, preferably corresponding in number with the numerals from 1 to 9, plus one for the zero character, or ten recesses in all, the said characters being placed upon the shell and exteriorly exposed directly opposite the respective recesses 30 or on radial lines passing centrally through the recesses. Instead of the zero character a slight protuberance 31 is formed on the shell to aid the operator in manipulating the tumblers in the dark for the purpose of solving the combination. This enables him to ascertain by feeling, where the zero character would be located if it were employed, thus giving him a starting point from which he can ascertain by moving the tumbler in either direction, when he has brought the desired numeral into the proper position for solving the combination, since every time a tumbler is moved a distance equal to that between two of the recesses 30, a distinct click is heard, due to the insertion of a spring 32 in the cylinder where it is surrounded by each tumbler, the said spring having an abrupt

bend 33 protruding slightly through a slot 34 formed in the cylinder 5 and adapted to spring with a click into each recess 30 of the tumbler as the recess passes the bend 33, the  
 5 click being due to the fact that the spring is first pressed inwardly and as soon as the slot 34 comes into register with a recess 30, the bend 33 moves outwardly thereinto. As illustrated in the drawing this spring 32 is  
 10 of sufficient width to engage the recesses of both members 25 of the tumbler, the recesses 30 of both members 25 being always in alinement.

Between the two tumbler members 25 is  
 15 located the ring member 26 having a single recess 36. The location of this ring in each tumbler determines the character upon the outer surface of the shell which enters into or identifies the combination. For instance,  
 20 when the ring 26 is placed in position the recess 36 may be placed in alinement with any pair of recesses 30 belonging to the two members 25. If it is desired to set the tumbler so that the numeral 5 shall form one of  
 25 the characters to indicate the combination, the recess 36 is placed in alinement with the two recesses 30 of the members 25 directly opposite or in radial arrangement with the numeral 5 on the exterior surface of the  
 30 tumbler shell. Then when the tumbler is turned to the proper position upon the cylinder, namely to such position that the three registering recesses 30, 36 and 30, shall be directly in alinement with the edge 37 of  
 35 the pallet and a slot 4 of the cylinder or hollow spindle through which the adjacent edge of the pallet protrudes when moved into position to unlock the shackle, this tumbler is properly adjusted for solving the  
 40 combination. If desired each of the other tumblers may have their members so assembled as that the numeral 5 may constitute the combination number of all the tumblers and if so, when the tumblers are so  
 45 arranged that the four 5s are in alinement with the edge 37 of the pallet, the combination is solved and the pallet may be actuated or moved laterally to cause its edge 37 to pass through the slot 4 of the hollow spindle  
 50 and enter the alined recesses 36 and 30 of all the tumblers, thus releasing the shackle and allowing it to be swung upon its pivot pin 15. Of course the members of each tumbler may be so arranged in the  
 55 shell as to make any numeral or the protuberance 31, corresponding with the zero character, an element of the combination. When a protuberance 31 is employed in this capacity the zero character is used to designate  
 60 it in expressing the combination.

The ring 26 of each tumbler is provided with studs 38 projecting from opposite sides thereof and adapted to enter recesses 30 of the two members 25 when the parts are assembled, whereby the relative arrangement

of the three members is constantly maintained when the members are once inserted in the shell. Whenever these studs are in position to enter two of the recesses 30 of the tumbler members 25, the recess 36 of the  
 70 ring 26 is always in alinement with one pair of recesses 30 of the two members 25.

The member 28 of each tumbler is secured in the shell of the latter at one extremity thereof and forms a stop which is engaged  
 75 by the adjacent tumbler member 25 when the parts of the tumbler are assembled. In other words, this ring 28 prevents the removable tumbler members from being crowded through the shell of the tumbler  
 80 during the operation of assembling, and prevents the said tumbler members from moving out of the shell in the direction of the said ring. The opposite extremity of the shell adjacent the other member 25 is  
 85 occupied by the divided or open expansion ring 27, whose tension is such as to retain it securely in place. It is, however, readily removable by design in order to detach the tumbler members 25 and 26 for the purpose  
 90 of changing the combination.

The cylinder cap 21 when the parts are assembled, is locked against endwise movement upon the cylinder by a spring 52 located in the cylinder and substantially identical with the spring 32 illustrated in Fig. 11 and heretofore described, the abrupt bend  
 95 53 of the spring 52 passing through a slot 39 formed in the adjacent extremity of the cylinder and entering a shallow registering recess 40 formed in the adjacent part of the inner surface of the cap (see Figs. 2 and 4). When the cap is rotatably adjusted to bring  
 100 its recess 40 into alinement with the slot 39 of the cylinder, the bend 53 of the spring enters the said recess and locks the cap in the proper assembled relation with the other parts so that the recessed extremity of the shackle may enter the respective openings 19  
 105 and 20 of the cap and cylinder.

If it is desired to remove the cap 21 after the shackle extremity is disengaged therefrom, it is only necessary to first give the cap a partial rotary movement, sufficient to disengage the bend 53 of the spring from the  
 115 shallow recess 40. The cap may then be detached from the cylinder by an endwise movement in an outward direction. When this is done the tumblers may be successively detached from the cylinder for any purpose,  
 120 as for changing the combination of the lock, for purposes of repair or the renewal of parts.

In order to retain the members 25 of each tumbler 23 in their proper relative position  
 125 within the shell, each of the members 25 is provided with an exteriorly projecting rib 41 adapted to enter a groove 42 formed in the shell 29 of the tumbler, where the protuberance 31 is located. The projections 41  
 130

readily slide into the grooves 42 when assembling the tumbler members, and after once they are in place the tumbler members can have no rotary movement independently of the shell with which they are connected. This is, of course, essential, since the relative arrangement of the characters upon the exterior surface of the shell with reference to the respective recesses 30 must be constant, for reasons that will be readily understood.

Attention is called to the fact that in the drawing the cylinder caps 14 and 21 are formed square in cross section, and when they are in place or when the parts of the lock are assembled, two of the corners of the caps are in longitudinal alinement with the slot 4 in the hollow spindle and the edge 37 of the pallet. This being the case, the person who solves the combination must bring the characters which identify the same into alinement with each other and also with two of the alined corners of the cylinder caps. The mechanism is so arranged that these two alined corners are in a plane cutting the case of the lock at right angles to the plane in which the pallet is located, the location of the numbers defining the combination when the latter is solved being also upon the front or near side of the lock when the latter is held with the pivotal extremity of the shackle toward the right.

Attention is called to the fact that the movement of the pallet is accomplished by pressing upon the protruding portions of the disk 9. For instance, when the tumblers are in position to solve the combination, the disk is pressed to cause the pallet to move outwardly through the slot 4 and into the recesses 30 and 36 of the tumbler members, while when it is desired to return the pallet to its position within the hollow spindle, the disk 9 is pressed to move the same in the opposite direction.

Having thus described my invention, what I claim is:

1. The combination with a hollow spindle provided with a longitudinal uninterrupted slot, a pallet laterally movable within the spindle and having a straight uninterrupted edge adapted to entirely enter the said slot, a shackle connected at one extremity with the spindle, its opposite extremity being adapted to enter the spindle, permutation devices rotatably mounted on the spindle and having recesses adapted to be brought into alinement and register with the slot in the spindle, the said alined recesses of the permutation devices being adapted to receive the edge of the pallet to permit the pallet to fall out of interlocking relation with the shackle, substantially as described.

2. In a permutation lock, the combination with a hollow spindle, of a pallet laterally movable therein, a permutation device rotatably mounted on the spindle and having re-

cesses, the hollow spindle being provided with a longitudinal uninterrupted slot adapted to receive one entire edge of the pallet, the permutation device being provided with recesses adapted to be brought into register with the slot in the spindle, the said recesses of the permutation device being adapted to receive the edge of the pallet when the latter is passed through the slot of the spindle, for the purpose set forth.

3. The combination with a hollow spindle, of a pallet laterally movable therein, a permutation device mounted on the spindle for controlling the lateral movement of the said pallet, and click springs located in the said spindle and having an abrupt outward bend intermediate their extremities protruding through the slots formed in the shell of the spindle and adapted to be engaged by the recesses of the permutation devices, for the purpose set forth.

4. The combination with a hollow spindle, of a pallet laterally movable therein, permutation devices mounted on the spindle and adjustable to control the lateral movement of the pallet, the opposite extremities of the spindle protruding beyond the permutation device, removable caps applied to the protruding extremities of the spindle, and a shackle pivotally connected with one protruding extremity of the spindle, the cap concealing the pivot of the shackle, the said cap being slotted on its flange and end to receive the shackle and allow it to open wide enough to permit the removal of the cap from the spindle to the shackle, substantially as described.

5. In a permutation lock, the combination with a hollow cylinder or spindle, of a pallet located therein and extending longitudinally thereof and laterally movable therein, a permutation device mounted on the cylinder and adjustable to control the lateral movement of the pallet, the pallet having projections at one extremity protruding through the shell of the spindle, and a member having an elongated opening through which the spindle passes, the projections of the pallet being engaged by the said member, the elongated opening in the member being of sufficient size to permit of lateral movement upon the spindle, whereby the said member may be moved and cause the pallet to be carried therewith, substantially as described.

6. A permutation device including a pallet member, a number of rings surrounding the pallet member and having a plurality of recesses, a ring interposed between the ring with a plurality of recesses and provided with a single recess adjustable to register with any recess of the first-named rings, and means for holding the rings in position in operative relation with the pallet member, for the purpose set forth.

7. A tumbler or permutation device including a shell, a tumbler member comprising a ring having a series of recesses, and a second ring having a single recess and adjustable to register with any recess of the first named ring, the said rings being located within the shell, the latter having exposed characters arranged thereon in alinement with the recesses of the rings, for the purpose set forth.

8. A tumbler comprising a shell, a tumbler member consisting of a ring having a series of radially arranged recesses communicating with the opening in the ring, and a second ring having a single recess and provided with pins adapted to enter recesses in the first named ring when the recess of the second ring is in alinement with any recess of the first named ring, the said rings being located in the shell, but removable therefrom, the first named ring being connected with the shell to prevent independent rotary movement when the parts are assembled, substantially as described.

9. A tumbler comprising a shell, two tumbler members consisting of rings each having a series of radially arranged recesses communicating with the central opening of the ring, and a third ring interposed between the first named rings and having a single recess adapted to register with any two alined recesses of the first named rings, the intermediate ring being adjustable with reference to the other rings and being constructed to close all of the recesses of both of the first named rings except those in alinement with its own recess, substantially as described.

10. A tumbler or permutation device comprising a cylindrical shell, a ring fixed in one extremity thereof, a removable spring ring located in the opposite extremity thereof, tumbler members located within the

shell between the said rings and comprising two flat rings each having a series of radially arranged recesses equi-distantly spaced, the recesses of the one ring being arranged to register with the recesses of the other ring, a third ring interposed between the first named rings and having a single recess adapted to register with any two alined recesses of the first named rings, and means for maintaining the third ring in the desired relation with the other rings, the three rings being removable from the shell, and the rings provided with the series of recesses being interlocked with the shell to prevent independent rotation, substantially as described.

11. The combination of a hollow spindle, a pallet extending longitudinally thereof and laterally movable therein, permutation devices rotatably mounted on the spindle for controlling the lateral movement of the pallet, and click springs located in the spindle and having abrupt outward bends protruding through slots formed in the spindle, the tumblers having interior recesses adapted to engage the said springs, for the purpose set forth.

12. The combination of a hollow spindle, tumblers rotatably mounted thereon and having recesses leading outwardly from the spindle, and click springs located in the spindle and having abrupt outward bends protruding through slots in the shell of the spindle and adapted to engage the recesses of the tumblers as the latter are rotated, substantially as described.

In testimony whereof I affix my signature in presence of two witnesses.

ELLSWORTH E. QUAINTANCE.

Witnesses:

F. E. BOWEN,  
A. EBERT O'BRIEN.