

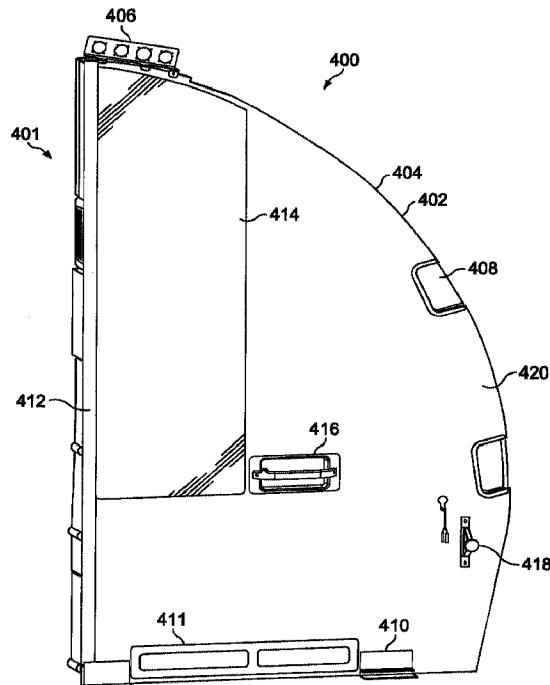

(22) **Date de dépôt/Filing Date:** 2019/08/01
 (41) **Mise à la disp. pub./Open to Public Insp.:** 2020/04/26
 (45) **Date de délivrance/Issue Date:** 2023/10/10
 (30) **Priorité/Priority:** 2018/10/26 (US16/172429)

(51) **Cl.Int./Int.Cl. B64D 11/02** (2006.01),
B64F 5/10 (2017.01), **B64F 5/40** (2017.01)
 (72) **Inventeur/Inventor:**
YOUNG, STEPHEN M., US
 (73) **Propriétaire/Owner:**
THE BOEING COMPANY, US
 (74) **Agent:** SMART & BIGGAR LP

(54) **Titre : MUR ARRIERE AMOVIBLE POUR STRUCTURE DE TOILETTES D'UN AERONEF**
 (54) **Title: REMOVABLE AFT WALL FOR A LAVATORY MONUMENT OF AN AIRCRAFT**



(57) **Abrégé/Abstract:**

An aircraft comprises a fuselage and an aft wall of a lavatory monument within the fuselage and extending radially inwardly relative to the fuselage. The aft wall is removably connected to an outboard wall, a ceiling, and a floor of the lavatory monument.

ABSTRACT

An aircraft comprises a fuselage and an aft wall of a lavatory monument within the fuselage and extending radially inwardly relative to the fuselage. The aft wall is removably connected to an outboard wall, a ceiling, and a floor of the lavatory monument.

5

REMOVABLE AFT WALL FOR A LAVATORY MONUMENT OF AN AIRCRAFT

BACKGROUND INFORMATION

Field:

5 The present disclosure relates generally to lavatory monuments on aircraft and more particularly to an aft wall having replaceable fixtures for a lavatory monument of an aircraft.

Background:

10 U.S. Patent Application No. **16/172,327** entitled “Improved Lavatory Monument for Aircraft”, discloses:

 An aircraft including a lavatory monument. The lavatory monument includes an outboard wall and a shell wall removably connected to the outboard wall, both walls extending radially inwardly relative to a fuselage of the aircraft. The lavatory
15 monument also includes a floor panel connected to and between the outboard wall and the shell wall. The lavatory monument also includes a toilet connected to the floor panel. The lavatory monument also includes a plurality of lavatory fixtures individually removably attached to at least one of: the outboard wall, the shell wall, the floor panel, or the toilet. Each of the plurality of lavatory fixtures is individually removable.
20 Common interface points on each of the plurality of lavatory fixtures are unchangeable with respect to the lavatory monument.

 U.S. Patent Application No. **16/172,247** entitled “Modular Faucet System for Aircraft”, discloses:

 A modular faucet system for an aircraft comprising a faucet outlet, a flow valve,
25 and an actuator. The faucet outlet is configured to be installed on the aircraft. The flow valve is configured to be installed on the aircraft separately from the faucet

outlet, to be connected by a first water line to a water supply comprising a water tank on the aircraft, and to be connected by a second water line to the faucet outlet. The actuator is configured to be installed on the aircraft separately from the faucet outlet and the flow valve. The actuator comprises a touchless sensor that is configured to
5 detect a user of the modular faucet system. The actuator is configured to generate a control signal to open the flow valve to provide water from the water supply to the faucet outlet in response to detection of the user by the touchless sensor.

Aircraft are subject to strict regulatory compliance standards in nearly every country in the world. In the United States, the Federal Aviation Administration
10 governs the standards for manufacturing, maintaining, and operating aircraft and ancillary concerns such as operating airports. The Federal Aviation Regulations (FARs) are organized into sections known as parts due to the organization within the Code of Federal Regulations. There are dozens of parts divided into tens of thousands of separate sections, many of which have large numbers of researchers
15 and technicians using them at any given time. In all, there are many thousands of pages of regulations that must be observed across the aircraft industry.

Of the FARs, part **21** deals with certification procedures for products and parts. These FARs also interact with other regulations, such as but not limited to parts **23-39** (dealing with airworthiness standards for different types of aircraft), part
20 **43** (maintenance), part **119** (certification of carriers), part **121** (operating requirements), part **125** (large passenger aircraft), and others.

Because of these extensive regulations, a technician or engineer cannot simply replace a part with something he or she sees in non-aircraft markets. Instead, new or replacement parts must either be pre-approved per regulations, or
25 approval must be obtained from the Federal Aviation Administration (or other regulatory body in countries other than the United States) in order to use new or different parts.

For example, aircraft lavatories, like any other parts of the aircraft, are subject to strict regulatory requirements. A great many design features are required, right

down to the height at which fluid lines are placed in the lavatory. Because of these regulations, aircraft lavatories for commercial aircraft have traditionally been constructed as whole units, known as “monuments”. More generally, a “monument” is a large, replaceable section of an inside of the aircraft designed for a purpose, such as but not limited to a lavatory. The monument design scheme allows, for example, a lavatory for a commercial aircraft to be approved by regulators as a whole and then installed in an aircraft.

However, this regulatory and design scheme results in a problem: if even a single component of the inside of the lavatory requires replacement, such as if a merely decorative flaw were to appear in a backsplash, then the entire lavatory monument (walls, floor, toilet, sink, everything) has to be removed and a new lavatory monument installed. It is not possible to simply remove and replace the backsplash. This problem is not easily solved because the heavy regulatory environment leads engineers to design entire lavatory monuments to meet regulatory requirements. To date, no solution to this problem has been presented. Instead, carriers and manufacturers have had to bear the cost of replacing entire lavatory monuments for even minor adjustments or corrections to a lavatory.

SUMMARY

An illustrative embodiment of the present disclosure provides an aircraft. The aircraft comprises a fuselage and an aft wall of a lavatory monument within the fuselage and extending radially inwardly relative to the fuselage. The aft wall is
5 removably connected to an outboard wall, a ceiling, and a floor of the lavatory monument.

Another illustrative embodiment of the present disclosure provides an aft wall configured to be removably connected to an outboard wall, a ceiling, and a floor of a lavatory monument. The aft wall comprises a curved outboard edge having a common
10 curvature, a metal bracket bonded to the curved outboard edge. The metal bracket is configured to removably connect the aft wall to the outboard wall.

Yet another illustrative embodiment of the present disclosure provides a method of constructing a lavatory monument in an aircraft, the lavatory monument having interchangeable sub-assemblies. A metal bracket is bonded to a curved
15 outboard edge of an aft wall. The metal bracket is joined to an outboard wall of the lavatory monument using a plurality of fasteners. The aft wall is removably connected to a ceiling and a floor of the lavatory monument.

In one embodiment, there is provided an aircraft that comprises a fuselage that comprises therein a lavatory monument. The lavatory monument comprises an aft
20 wall. The aft wall is configured to be removably connected to an outboard wall of the lavatory monument. The aft wall comprises: an outboard edge that curves radially inwardly relative to the fuselage; a bracket bonded to the outboard edge, wherein the bracket covers a portion of the outboard edge; and fasteners configured to removably connect the bracket to the outboard wall.

25 In another embodiment, there is provided an aft wall installed in an aircraft and configured to be removably connected to an outboard wall of a lavatory monument. The aft wall comprises: a curved outboard edge having a common curvature; a bracket

bonded to the curved outboard edge, wherein the bracket covers a portion of the curved outboard edge; and fasteners configured to removably connect the bracket to the outboard wall.

5 In another embodiment, there is provided a method of constructing a lavatory monument in an aircraft, the lavatory monument having interchangeable sub-assemblies. The method comprises: bonding a bracket to a curved outboard edge of an aft wall, wherein the bracket covers a portion of the curved outboard edge; joining the bracket to an outboard wall of the lavatory monument using a plurality of fasteners; and removably connecting the aft wall to a ceiling and a floor of the lavatory
10 monument.

In another embodiment, there is provided a method of performing maintenance on a lavatory monument in an aircraft, the lavatory monument having interchangeable sub-assemblies. The method comprises: removing an existing interchangeable sub-assembly from the lavatory monument, wherein the existing interchangeable sub-
15 assembly is removably connected to the lavatory monument and wherein the existing interchangeable sub-assembly is an existing aft wall of the lavatory monument; and removably connecting a new interchangeable sub-assembly to the lavatory monument. The new interchangeable sub-assembly is a new aft wall of the lavatory monument configured to be removably connected to an outboard wall, a ceiling, and
20 a floor of the lavatory monument. The new aft wall comprises: a curved outboard edge having a common curvature; a bracket bonded to the curved outboard edge, wherein the bracket covers a less than whole portion of the curved outboard edge; and fasteners configured to removably connect the bracket to the outboard wall.

25 In another embodiment, there is provided an aircraft comprising a fuselage that comprises therein a lavatory monument. The lavatory monument comprises an aft wall extending radially inwardly relative to the fuselage. The aft wall is configured to be removably connected to an outboard wall, a ceiling, and a floor of the lavatory monument. The aft wall has unchangeable connection points configured to join the aft wall to the outboard wall, the ceiling, and the floor of the lavatory monument. The aft

wall has an outboard edge having a common curvature which mirrors a concave curvature of the outboard wall. The unchangeable connection points comprise a metal bracket bonded to the outboard edge to removably connect the aft wall to the outboard wall. The metal bracket comprises a first flange and a second flange forming a channel, wherein the outboard edge is positioned within the channel of the metal bracket.

In another embodiment, there is provided a method of performing maintenance on a lavatory monument in an aircraft, the lavatory monument having interchangeable sub-assemblies. The method comprises removing an existing interchangeable sub-assembly from the lavatory monument. The existing interchangeable sub-assembly is removably connected to the lavatory monument and comprises an existing aft wall of the lavatory monument. Removing the existing aft wall comprises releasing the existing aft wall at unchangeable connection points between the existing aft wall and an outboard wall, a ceiling, and a floor of the lavatory monument. The existing aft wall has a common curvature for an outboard edge of the existing aft wall and the outboard edge is convex and mirrors a concave curvature of the outboard wall. The unchangeable connection points comprise a metal bracket bonded to the outboard edge to removably connect the existing aft wall to the outboard wall. The metal bracket comprises a first flange and a second flange forming a channel, wherein the curved outboard edge is positioned within the channel of the metal bracket. The method further comprises removably connecting a new interchangeable sub-assembly to the lavatory monument, wherein the new interchangeable sub-assembly comprises a new aft wall of the lavatory monument.

The features and functions can be achieved independently in various embodiments of the present disclosure or may be combined in yet other embodiments in which further details can be seen with reference to the following description and drawings.

BRIEF DESCRIPTION OF THE DRAWINGS

The illustrative embodiments, as well as a preferred mode of use, further objectives and features thereof, will best be understood by reference to the following detailed description of an illustrative embodiment of the present disclosure when read
5 in conjunction with the accompanying drawings, wherein:

Figure 1 is an illustration of an exploded view of an aircraft modular lavatory monument in accordance with an illustrative embodiment;

Figure 2 is an illustration of a view of a lavatory monument of an aircraft upon entering the aircraft in accordance with an illustrative embodiment;

10 **Figure 3** is an illustration of a block diagram of a lavatory monument within an aircraft in accordance with an illustrative embodiment;

Figure 4 is an illustration of an interior side of an aft wall in accordance with an illustrative embodiment;

15 **Figure 5** is an illustration of an external side of an aft wall in accordance with an illustrative embodiment;

Figure 6 is an illustration of an external side of an aft wall without non-lavatory features attached in accordance with an illustrative embodiment;

Figure 7 is an illustration of a bottom edge of an aft wall configured to be joined to a floor of a lavatory monument in accordance with an illustrative embodiment;

20 **Figure 8** is an illustration of an inboard edge of an aft wall configured to be joined to a modular door of a lavatory monument in accordance with an illustrative embodiment;

Figure 9 is an illustration of a top view of a curved outboard edge of an aft wall configured to be joined to an outboard wall of a lavatory monument in accordance with an illustrative embodiment;

Figure 10 is an illustration of a side view of a metal bracket bonded to a curved outboard edge of an aft wall configured to be joined to an outboard wall of a lavatory monument in accordance with an illustrative embodiment;

Figure 11 is an illustration of a cross-sectional view of a metal bracket bonded to a curved outboard edge of an aft wall configured to be joined to an outboard wall of a lavatory monument in accordance with an illustrative embodiment;

Figure 12 is an illustration of a perspective view of a front of a metal bracket in accordance with an illustrative embodiment;

Figure 13 is an illustration of a side view of a metal bracket in accordance with an illustrative embodiment;

Figure 14 is an illustration of a top view of a metal bracket in accordance with an illustrative embodiment;

Figure 15 is an illustration of a bottom view of a metal bracket in accordance with an illustrative embodiment;

Figure 16 is an illustration of an interior side of an aft wall in accordance with an illustrative embodiment;

Figure 17 is an illustration of an external side of an aft wall in accordance with an illustrative embodiment;

Figure 18 is an illustration of a bottom edge of an aft wall configured to be joined to a floor of a lavatory monument in accordance with an illustrative embodiment;

Figure 19 is an illustration of a side view of a metal bracket bonded to a curved outboard edge of an aft wall configured to be joined to an outboard wall of a lavatory monument in accordance with an illustrative embodiment;

Figure 20 is an illustration of a cross-sectional view of a metal bracket bonded to a curved outboard edge of an aft wall configured to be joined to an outboard wall of a lavatory monument in accordance with an illustrative embodiment;

5 **Figure 21** is an illustration of a perspective view of a front of a metal bracket in accordance with an illustrative embodiment;

Figure 22 is an illustration of a top view of a metal bracket in accordance with an illustrative embodiment;

Figure 23 is an illustration of a bottom view of a metal bracket in accordance with an illustrative embodiment;

10 **Figure 24** is an illustration of a back view of a metal bracket in accordance with an illustrative embodiment;

Figure 25 is a flowchart of a method for constructing a lavatory monument in an aircraft, the lavatory monument having interchangeable sub-assemblies in accordance with an illustrative embodiment;

15 **Figure 26** is a flowchart of a method for of performing maintenance on a lavatory monument in an aircraft, the lavatory monument having interchangeable sub-assemblies in accordance with an illustrative embodiment;

Figure 27 is an illustration of an aircraft manufacturing and service method in the form of a block diagram in accordance with an illustrative embodiment; and

20 **Figure 28** is an illustration of an aircraft in the form of a block diagram in accordance with an illustrative embodiment.

DETAILED DESCRIPTION

The different illustrative embodiments recognize and take into account a number of different considerations. For example, the illustrative embodiments recognize and take into account that, due to the heavy regulatory environment of aircraft, aircraft lavatory monuments are not modular. In other words, while the monument itself is replaceable, the components and parts inside the lavatory are not.

In an effort to support customers with increasing demand for customization and features, the illustrative embodiments provide for an aircraft lavatory monument design was developed with the intention of providing additional feature selections, which would allow customers to differentiate their brands and provide increased levels of service. To accomplish the goal of allowing maximum customization with minimal engineering impact, a modular design system was developed. The modular nature of the concept allows multiple sub-assemblies to be removed and replaced without impacting the surrounding assemblies.

This modularity is achieved, while maintaining the requirements of a heavy regulatory environment, by creating common interface points on each sub assembly that are not allowed to change throughout the different modular packages offered. Additionally, the design is carefully laid out such that each component has an acceptable removal envelope, and optimized to reduce the quantity and accessibility of fasteners required.

As used herein, the term “modular” refers to a component which is removably attached to at least one other component or fixture. The term “modular” with respect to a component or fixture automatically contemplates common interface points on the component that are unchangeable with respect to the lavatory monument; that is, the common interface points are not considered “modular.”

The terms “removably attached” or “removeable attachment” refer to a component, fixture, or connection that is easily or quickly replaceable either by hand

or the use of tools in a manner that is considered “easy” or “fast” by one of ordinary skill in the art. The terms “easy” or “fast” are determined relative to components that are fixedly attached, or stated differently, intended for permanent and unchanged attachment or formed monolithically with another part of a component. As used
5 herein, the term “about” or “approximately” when used with respect to measurements is determined by the ordinary artisan and is within acceptable engineering tolerances in the regulatory scheme for a given jurisdiction, such as but not limited to the Federal Aviation Administration Federal Aviation Regulations. The term “fixture” refers to a component that can be replaced as an individual unit, such as but not
10 limited to a sink, a faucet, a cabinet, an alcove panel shaped to present an alcove inside the lavatory monument, a toilet paper holder, a drawer, a liquid hose line, a soap dispenser, a soap holder, a towel dispenser, a towel holder, a drawer, a backsplash, a waste receptacle, a counter top, a light strip, a light bulb, a lightable sign, a mirror, a display device, a speaker, a crew signal button, a switch, a panel, a
15 cup holder, an airsick bag dispenser, a tissue dispenser, a sanitary napkin dispenser, a cologne rack, and a shelf.

The illustrative embodiments recognize and take into account that rework of an aircraft lavatory is also undesirably costly. The illustrative embodiments recognize and take into account that rework of an aircraft lavatory requires
20 disassembly of large sections of the aircraft lavatory. The illustrative embodiments recognize and take into account that rework or repairs run into the physical problems of disassembling the lavatory and accessing the damaged areas.

The illustrative examples further recognize that in conventional aircraft lavatories, it is much more difficult to change a design for an object than to replace
25 the object that is damaged. For example, changing the shape of a countertop or a sink type may be undesirably difficult due to the regulatory reasons above.

The illustrative embodiments recognize and take into account that to build conventional aircraft lavatory monuments, an aft wall would be bonded with a tab and slot joint. The illustrative embodiments recognize and take into account that

once bonded, the aft wall cannot be removed from the tab and slot joint. The illustrative embodiments recognize and take into account that it is undesirable to have visible fasteners within the passenger cabin of an aircraft.

Turning now to **Figure 1**, an exploded view of an aircraft modular lavatory monument is depicted in accordance with an illustrative embodiment. Aircraft modular lavatory monument **100**, as indicated above, is provided with common interface points on each sub assembly (the plurality of removably attached lavatory fixtures) that are not allowed to change throughout the different modular packages offered. Thus, common interface points on each of the plurality of lavatory fixtures are unchangeable with respect to the lavatory monument. Additionally, the design is laid out such that each component (the plurality of removably attached lavatory fixtures) has an acceptable removal envelope, and optimized to reduce the quantity of and increase the accessibility of fasteners required.

Aircraft modular lavatory monument **100** includes modular outboard wall **102** which is intended for removeable attachment to a fuselage of an aircraft. Thus, modular outboard wall **102** may be considered part of a frame for aircraft modular lavatory monument **100**. Optionally, aircraft modular lavatory monument **100** may be provided with window **104**, which is placed, sized, and dimensioned to match a window in the corresponding model of aircraft for which aircraft modular lavatory monument **100** is intended.

Aircraft modular lavatory monument **100** also includes modular shell wall **106**, which also forms part of the frame for aircraft modular lavatory monument **100**. Optionally, ballistic intrusion barrier **108** may also be provided, if desirable. In a still further option, modular shell wall **106** may be replaced by ballistic intrusion barrier **108**, in which case ballistic intrusion barrier **108** is “modular”. In either case, the corresponding wall or barrier is removably attached to modular outboard wall **102** and radiates inwardly towards a central axis of the fuselage of the aircraft. While shown as radiating at a perpendicular angle to modular outboard wall **102**, the angle shown may be varied in different illustrative embodiments.

Aircraft modular lavatory monument **100** also includes modular aft wall **110**. The term “aft” is used herein merely to distinguish modular shell wall **106** from modular aft wall **110**. Modular aft wall **110** also forms part of the frame of aircraft modular lavatory monument **100**. While the typical aircraft modular lavatory monument will have modular aft wall **110** actually facing the aft portion of an aircraft, this arrangement is not necessary for all illustrative embodiments. For example, the components shown on modular aft wall **110** could face the “forward” portion of the aircraft, at which point modular aft wall **110** becomes a “modular forward wall”. Note, also, that the various sub-components or fixtures shown on either modular shell wall **106** or modular aft wall **110** may be re-arranged, reversed with respect to which side of the wall to which they are attached, or otherwise altered with more or fewer sub-components or fixtures.

Aircraft modular lavatory monument **100** also includes modular toilet **112**, modular toilet shroud **114** attached to modular toilet **112**, and modular floor pan **116** to which modular toilet **112** is also attached. Modular toilet **112** is attached to a waste disposal system contained in the fuselage of the aircraft. Optionally, a bidet may be provided inside or next to modular toilet **112**. In the latter case, the bidet may have a bidet shroud similar to modular toilet shroud **114** shown in **Figure 1**.

Aircraft modular lavatory monument **100** also includes modular door **118**. Modular door **118** may be a folding door, a slab door, a hinged door, a pocket door, or any other desirable door design. Modular door **118** is removably connected to one or both of modular shell wall **106** or modular aft wall **110**.

Aircraft modular lavatory monument **100** also includes modular upper cabinet system **120**. Modular upper cabinet system **120** is one or more modular cabinets, drawers, mirrors or other fixtures which are attached at or about chest height or higher for an average adult female or male (or possibly a child in some illustrative embodiments).

Aircraft modular lavatory monument **100** also includes backsplash assembly **121**. Backsplash assembly **121** is independently removably attached to modular

shell wall **106** relative to the other components of aircraft modular lavatory monument **100**.

Aircraft modular lavatory monument **100** also includes modular counter system **122**. Modular counter system **122** is one or more modular sinks, backsplashes, waste receptacle openings, soap holders, soap dispensers, towel dispensers, or other fixtures that are about between about waist and chest height for an average adult female or male (or possibly a child in some illustrative embodiments).

Aircraft modular lavatory monument **100** also includes lower cabinet assembly **124**. Lower cabinet assembly **124** is one or more modular cabinets, toilet paper dispensers, doors, drawers, tissue dispensers, waste receptacles, or other fixtures that are about between about waist and chest height for an average adult female or male (or possibly a child in some illustrative embodiments). In some illustrative examples, lower cabinet assembly **124**, may be referred to as a modular lower cabinet assembly.

The various modular components and fixtures shown in **Figure 1** may be varied. More or fewer fixtures or walls may be present. The arrangement, type, and style of fixtures or wall may be varied. Additional details regarding some of these variations are described below with respect to **Figure 2** through **Figure 25**.

Turning now to **Figure 2**, an illustration of a view of a lavatory monument of an aircraft upon entering the aircraft is depicted in accordance with an illustrative embodiment. Lavatory monument **200** may be an example of aircraft modular lavatory monument **100** as assembled in an aircraft. Upon entering aircraft **202**, aft wall **204** is visible to passengers. Aft wall **204** may be the same as modular aft wall **110** of **Figure 1**.

External side **206** of aft wall **204** is visible to passengers upon entering aircraft **202**. External side **206** of aft wall **204** has plurality of non-lavatory features **208**.

Unchangeable connection points to join aft wall **204** to lavatory monument **200** are not visible to passengers entering aircraft **202**.

Turning now to **Figure 3**, an illustration of a block diagram of a lavatory monument within an aircraft is depicted in accordance with an illustrative embodiment. Aircraft **300** comprises fuselage **302** and aft wall **304** of lavatory monument **306** within fuselage. Aircraft **202** of **Figure 2** may be a physical implementation of aircraft **300**. Modular aft wall **110** of **Figure 1** and aft wall **204** of **Figure 2** are physical implementations of aft wall **304**. Aft wall **304** extends radially inward toward fuselage.

Aft wall **304** is removably connected to outboard wall **308**, ceiling **310**, and floor **312** of lavatory monument **306**. Aft wall **304** has plurality of common interface points **314** for joining plurality of non-lavatory features **316** to aft wall **304**. Aft wall **304** is subject to aircraft regulatory requirements.

Plurality of common interface points **314** enable removal and replacement of any of plurality of non-lavatory features **316**. Plurality of non-lavatory features **316** is replaceable without removing aft wall **304**. Each of plurality of non-lavatory features **316** is interchangeable with other non-lavatory features having a respective set of common interface points of plurality of common interface points **314**.

Plurality of common interface points **314** takes any desirable form. In some illustrative examples, plurality of common interface points **314** comprises fasteners with threaded holes in aft wall **304**. In other illustrative examples, plurality of common interface points **314** comprises fasteners with threaded shafts extending outwardly from external side **342** of aft wall **304**.

Aircraft **300** further comprises plurality of non-lavatory features **316**. In some illustrative examples, plurality of non-lavatory features **316** comprise at least one of an attendant seat, cabinetry, a display screen, or a user interface. Each of plurality of non-lavatory features **316** is replaceable without removing aft wall **304**. Each of

plurality of non-lavatory features **316** is removeable due to the connections between plurality of non-lavatory features **316** and aft wall **304**.

In some illustrative examples, non-lavatory features of plurality of non-lavatory features **316** are grouped into modules. Modules are groupings of non-lavatory features of plurality of non-lavatory features **316** that may be removed and replaced as a whole. For example, a module containing more than one non-lavatory feature of plurality of non-lavatory features **316** is removed and replaced as a whole. In one non-limiting example, multiple cabinets form a cabinetry module of non-lavatory features. In this example, the cabinetry module may be removed and replaced as a whole. Any desirable type of non-lavatory features and any desirable quantity of non-lavatory features may be grouped into a module.

By having plurality of common interface points **314**, plurality of non-lavatory features **316** is removable and replaceable. Plurality of common interface points **314** enables replacement of any of plurality of non-lavatory features **316** without redesigning aft wall **304**. Plurality of common interface points **314** enables replacement of any of plurality of non-lavatory features **316** without removing aft wall **304**. Any of plurality of non-lavatory features **316** may be removed and replaced due to maintenance or reconfiguration of services to be provided. For example, a storage cabinet of plurality of non-lavatory features **316** may be removed and replaced with a different type of non-lavatory feature, such as a touch screen, a storage shelf, a foldable diaper changer, or any other type of non-lavatory feature. As another example, a storage cabinet of plurality of non-lavatory features **316** may be removed and replaced with a same design of storage cabinet as part of maintenance of aircraft **300**.

Aft wall **304** has unchangeable connection points **318** configured to join the aft wall **304** to outboard wall **308**, ceiling **310**, and floor **312** of the lavatory monument **306**. Unchangeable connection points **318** are the same for all designs of aft wall **304**. Unchangeable connection points **318** are not allowed to change throughout the different modular packages offered for aft wall **304**. Unchangeable

connection points **318** are common to various designs of aft wall **304** such that unchangeable connection points **318** are at a predetermined location and/or have a predetermined size. Unchangeable connection points **318** take the form of any desirable type of connections. Unchangeable connection points **318** have any
5 desirable shape, location, and type. By having unchangeable connection points **318**, aft wall **304** may be removed and replaced with another aft wall having unchangeable connection points **318**.

Outboard wall **308** is connected to inside surface **320** of fuselage **302**. Aft wall **304** is connected to outboard wall **308** by respective connection points of
10 unchangeable connection points **318**.

Aft wall **304** has common curvature **322** for curved outboard edge **324** of aft wall **304**. Curved outboard edge **324** is convex **326** and mirrors concave curvature **328** of outboard wall **308**. For example, curved outboard edge **324** may have a similar radius of curvature as outboard wall **308** such that outboard edge **324** nests
15 within outboard wall **308**. Aft wall **304** may be replaced with another aft wall having common curvature **322**.

Unchangeable connection points **318** comprise metal bracket **330** bonded to curved outboard edge **324** of aft wall **304**. Metal bracket **330** is bonded to curved outboard edge **324** using any desirable type of adhesive material. In some
20 illustrative examples, metal bracket **330** is bonded to curved outboard edge **324** using a two-part epoxy. The adhesive material used to bond metal bracket **330** to curved outboard edge **324** is selected to provide a desired strength. The adhesive material used to bond metal bracket **330** to curved outboard edge **324** is selected such that the bond does not undesirably degrade or undesirably affect the material
25 of aft wall **304**.

In some illustrative examples, unchangeable connection points **318** comprises more than one metal bracket bonded to curved outboard edge **324**. In some illustrative examples, metal bracket **330** joins aft wall **304** to ceiling **310**. In some illustrative examples, metal bracket **330** joins aft wall **304** to outboard wall **308**.

As depicted, unchangeable connection points **318** include fasteners **332** joining metal bracket **330** to outboard wall **308**. Fasteners **332** are not visible to a passenger outside of lavatory monument **306**.

5 Metal bracket **330** comprises first flange **334** and second flange **336** forming channel **338**. Curved outboard edge **324** is positioned within channel **338** of metal bracket **330**.

10 First flange **334** of metal bracket **330** contacts internal side **340** of aft wall **304**. Internal side **340** faces into lavatory monument **306**. Second flange **336** of metal bracket **330** contacts external side **342** of aft wall **304**. External side **342** faces into a passenger cabin of aircraft **300** and away from lavatory monument **306**.

In some illustrative examples, metal bracket **330** further comprises fastening flange **344**. In some illustrative examples, fasteners **332** connect fastening flange **344** of metal bracket **330** to outboard wall **308**.

15 Metal bracket **330** has any desirable cross-sectional shape and any desirable length. Metal bracket **330** is designed to be bonded to curved outboard edge **324** of aft wall **304**. In some illustrative examples, metal bracket **330** is designed to be removably connected to outboard wall **308** without being visible to passengers of aircraft **300**. In some illustrative examples, metal bracket **330** is designed to be removably connected to ceiling **310** without being visible to passengers of aircraft
20 **300**.

In some illustrative examples, metal bracket **330** has F-shaped cross-section **346**. In some illustrative examples, F-shaped cross-section **346** is formed when fastening flange **344** is perpendicular to first flange **334** and second flange **336**. In some illustrative examples, metal bracket **330** has z-shaped cross-section **348**. In
25 some illustrative examples, z-shaped cross-section **348** is formed when fastening flange **344** is parallel to first flange **334** and second flange **336**.

Unchangeable connection points **318** comprises floor fittings **350**. Floor fittings **350** removably connect aft wall **304** to floor **312**. In some illustrative

examples, aft wall **304** is removed and replaced with another aft wall having floor fittings **350**. Aft wall **304** is configured to be removed without removing lavatory monument **306** from aircraft **300**.

By removing aft wall **304** without removing lavatory monument **306**, aft wall
5 **304** may be removed for maintenance. For example, by removing aft wall **304**
without removing lavatory monument **306**, aft wall **304** may be replaced with an aft
wall of a same design as aft wall **304** when aft wall **304** is showing wear from normal
use. As another example, by removing aft wall **304** without removing lavatory
monument **306**, aft wall **304** may be replaced with an aft wall having a different
10 design. For example, aft wall **304** may be removed and replaced with an aft wall
without plurality of common interface points **314**. In one illustrative example, aft wall
304 is removed and replaced with an aft wall with a decorative surface without
plurality of common interface points **314**.

The illustration of aft wall **304** in **Figure 3** is not meant to imply physical or
15 architectural limitations to the manner in which an illustrative embodiment may be
implemented. Other components in addition to or in place of the ones illustrated
may be used. Some components may be unnecessary. Also, the blocks are
presented to illustrate some functional components. One or more of these blocks
may be combined, divided, or combined and divided into different blocks when
20 implemented in an illustrative embodiment.

For example, aft wall **304** may not have plurality of common interface points
314. In some illustrative examples, aft wall **304** has a decorative surface, not
depicted in **Figure 3**. In some illustrative examples, the decorative surface may be
installed using plurality of common interface points **314**. In some illustrative
25 examples, plurality of common interface points **314** are not present and decorative
surface is present on aft wall **304**. In some illustrative examples, the decorative
surface takes the form of a decorative laminate or any other aesthetically desirable
surface.

As another example, one of first flange **334** and second flange **336** may be optional. In some illustrative examples, second flange **336** is not present, for example, in z-shaped cross-section **348**. As yet another example, although not depicted, metal bracket **330** may have an h-shaped cross-section.

5 Turning now to **Figure 4**, an illustration of an interior side of an aft wall is depicted in accordance with an illustrative embodiment. Aft wall **400** is a physical implementation of aft wall **304** of **Figure 3**. Aft wall **400** may be modular aft wall **110** of **Figure 1**.

10 As depicted, aft wall **400** is an implementation of an aft wall adjacent an aircraft entry door. Aft wall **400** may be the same as aft wall **204** of **Figure 2**.

View **401** of aft wall **400** is an interior view within a lavatory, such as aircraft modular lavatory monument **100** of **Figure 1**. Aft wall **400** has common curvature **402** for curved outboard edge **404** of aft wall **400**. Curved outboard edge **404** is convex and mirrors a concave curvature of an outboard wall (not depicted).

15 Aft wall **400** has a plurality of unchangeable connection points. In view **401**, the plurality of unchangeable connection points comprises metal bracket **406** bonded to curved outboard edge **404** of aft wall **400**.

20 Aft wall **400** comprises aircraft door flaps **408**. Aircraft door flaps **408** in aft wall **400** allow aircraft door snubbers (not depicted) to pass through aft wall **400** when the aircraft entry door (not depicted) is opened.

The plurality of unchangeable connection points comprises floor fittings **410** on base **411** of aft wall **400**. Inboard edge **412** of aft wall **400** interfaces with a door for a lavatory monument.

25 Aft wall **400** also includes mirror **414** and assist handle **416**. As illustrated, assist handle **416** includes a bag hook on one side. Aft wall **400** also includes routing **418** for door heat grille providing heated air. Each of mirror **414** and assist handle **416** are on internal side **420** of aft wall **400**. When installed in an aircraft, internal side **420** faces into a lavatory monument.

Turning now to **Figure 5**, an illustration of an external side of an aft wall is depicted in accordance with an illustrative embodiment. Aft wall **500** is a physical implementation of aft wall **304** of **Figure 3**. Aft wall **500** may be modular aft wall **110** of **Figure 1**.

5 As depicted, aft wall **500** is an implementation of an aft wall adjacent an aircraft entry door. Aft wall **500** may be the same as aft wall **204** of **Figure 2**.

As depicted, aft wall **500** is an implementation of an aft wall of a lavatory that is adjacent to an aircraft entry door. View **501** of aft wall **500** is a view of aft wall **500** outside of a lavatory, such as aircraft modular lavatory monument **100** of **Figure 1**.
10 For example, aft wall **500** may be an implementation of an external side of aft wall **400** of **Figure 4**. External side **524** of aft wall **500** is the side of aft wall **500** visible to passengers upon entering an aircraft, such as aircraft **2800** of **Figure 28**.

Aft wall **500** has common curvature **502** for curved outboard edge **504** of aft wall **500**. Curved outboard edge **504** is convex and mirrors a concave curvature of
15 an outboard wall (not depicted).

Aft wall **500** has a plurality of unchangeable connection points. In view **501**, the plurality of unchangeable connection points comprises metal bracket **506** bonded to curved outboard edge **504** of aft wall **500**.

Aft wall **500** comprises aircraft door flaps **508**. Aircraft door flaps **508** in aft
20 wall **500** allow aircraft door snubbers (not depicted) to pass through aft wall **500** when the aircraft entry door (not depicted) is opened.

The plurality of unchangeable connection points comprises floor fittings **510** on base **511** of aft wall **500**. Inboard edge **512** of aft wall **500** interfaces with a door for a lavatory monument.

25 Aft wall **500** comprises plurality of non-lavatory features **513**. Plurality of non-lavatory features **513** comprises cabinetry as well as display screen **514**, user interface **516**, foldable attendant seat **518**, foldable diaper changing table **520**, and storage **522**.

In some illustrative embodiments, aft wall **500** is provisioned for a large number of interfaces, including attendant seats, such as foldable attendant seat **518**. It is desirable for aft walls, such as aft wall **500**, to be designed in terms of shape and materials to hold high loads due to attendant seats and other equipment
5 interfaces. Conventional attendant seat plug and sleeve inserts would undesirably be seen from the inside of the lavatory. In some illustrative examples, aft wall **500** has imbedded foam kits and metal details to deal with wire pass throughs and attendant seat mounting.

It is also desirable for an aircraft electrical umbilical to route through aft wall
10 **500**. In some illustrative examples, wiring clamshells (not depicted) are provided in aft wall **500**. In some illustrative examples, aft wall **500** is provided with the aircraft electrical umbilical interface for the lavatory. In some illustrative examples, the aft wall is provided with an environmental control system (ECS) routing for a door heat grille.

15 Each component of plurality of non-lavatory features **513** of aft wall **500** of **Figure 5** is removeable and replaceable. Each component of plurality of non-lavatory features **513** is connected to aft wall **500** using a plurality of common interface points.

In some illustrative examples, non-lavatory features of plurality of non-lavatory
20 features **513** are grouped into modules. Modules are groupings of non-lavatory features of plurality of non-lavatory features **513** that may be removed and replaced as a whole. For example, a module containing more than one non-lavatory feature of plurality of non-lavatory features **513** is removed and replaced as a whole. In one non-limiting example, multiple cabinets form a cabinetry module of non-lavatory
25 features. In this example, the cabinetry module may be removed and replaced as a whole. Any desirable type of non-lavatory features and any desirable quantity of non-lavatory features may be grouped into a module.

Other options, styles, and arrangements are also possible. The illustrative examples shown in **Figures 4** and **5** are not meant to imply physical or architectural limitations to the manner in which an illustrative embodiment may be implemented.

Turning now to **Figure 6**, an illustration of an external side of an aft wall without non-lavatory features attached is depicted in accordance with an illustrative embodiment. Aft wall **600** is a physical implementation of aft wall **304** of **Figure 3**. Aft wall **600** may be modular aft wall **110** of **Figure 1** without any non-lavatory features. As depicted, aft wall **600** is an implementation of an aft wall adjacent an aircraft entry door. Aft wall **600** may be the same as aft wall **204** of **Figure 2**.

Aft wall **600** may be an implementation of an external side of aft wall **400** of **Figure 4**. View **601** of aft wall **600** is the side of aft wall **600** visible to passengers upon entering an aircraft, such as aircraft **2800** of **Figure 28**.

Aft wall **600** has common curvature **602** for curved outboard edge **604** of aft wall **600**. Curved outboard edge **604** is convex and mirrors a concave curvature of an outboard wall (not depicted).

Aft wall **600** has a plurality of unchangeable connection points. In view **601**, the plurality of unchangeable connection points comprises metal bracket **606** bonded to curved outboard edge **604** of aft wall **600**.

Aft wall **600** comprises aircraft door flaps **608**. Aircraft door flaps **608** in aft wall **600** allow aircraft door snubbers (not depicted) to pass through aft wall **600** when the aircraft entry door (not depicted) is opened.

The plurality of unchangeable connection points comprises floor fittings **610** on base **611** of aft wall **600**. Inboard edge **612** of aft wall **600** interfaces with a door for a lavatory monument.

As depicted, plurality of common interface points **618** is visible on external side **614** of aft wall **600**. Plurality of common interface points **618** is present on external side **614** of aft wall **600** to connect a plurality of non-lavatory features to

external side **614** of aft wall **600**. As depicted, plurality of common interface points **618** comprises fasteners with threaded holes in aft wall **600**.

Turning now to **Figure 7**, an illustration of a bottom edge of an aft wall configured to be joined to a floor of a lavatory monument is depicted in accordance with an illustrative embodiment. View **700** is a bottom view of aft wall **600** of **Figure 6**. In view **700**, floor fitting **702** and floor fitting **704** are visible. Floor fitting **702** and floor fitting **704** are unchangeable connection points to removably connect aft wall **600** to a floor.

Aft wall **600** also comprises assist handle **706** and routing **708** on internal side **710** of aft wall **600**.

Turning now to **Figure 8**, an illustration of an inboard edge of an aft wall configured to be joined to a modular door of a lavatory monument is depicted in accordance with an illustrative embodiment. View **800** is a view of inboard edge **612** of aft wall **600** of **Figures 6-7**. Inboard edge **612** is configured to be joined to a door assembly of a lavatory monument.

Turning now to **Figure 9**, an illustration of a top view of a curved outboard edge of an aft wall configured to be joined to an outboard wall of a lavatory monument is depicted in accordance with an illustrative embodiment. View **900** is a top view of aft wall **600** of **Figures 6-8**. In view **900**, bracket **606** is visible. Bracket **606** is configured to join aft wall **600** to an outboard wall (not depicted).

Turning now to **Figure 10**, an illustration of a side view of a metal bracket bonded to a curved outboard edge of an aft wall configured to be joined to an outboard wall of a lavatory monument is depicted in accordance with an illustrative embodiment. View **1000** is a view of curved outboard edge **604** of aft wall **600** of **Figures 6-9**.

Although not depicted in view **1000**, in some illustrative examples, more than one bracket connects aft wall **600** to an outboard wall. In some illustrative examples, another bracket in addition to bracket **606** is bonded to curved outboard edge **604** of

aft wall **600**. For example, another bracket may be bonded to curved outboard edge **604** at location **1002**. As another example, another bracket may be bonded to curved outboard edge **604** at location **1004**.

Turning now to **Figure 11**, an illustration of a cross-sectional view of a metal
5 bracket bonded to a curved outboard edge of an aft wall configured to be joined to
an outboard wall of a lavatory monument is depicted in accordance with an
illustrative embodiment. View **1100** is a cross-sectional view of bracket **606** bonded
to curved outboard edge **604**.

In cross-sectional view **1100** of bracket **606**, first flange **1102** is visible. First
10 flange **1102** is in contact with internal side **710** of aft wall **600**. Fastening flange
1104 extends upward from aft wall **600**.

The illustrative examples provide an ornamental design for a metal bracket for
an aft wall of an aircraft lavatory monument. Each of **Figures 12-15** provide views of
the metal bracket of this design.

Turning now to **Figure 12**, an illustration of a perspective view of a front of a
15 metal bracket is depicted in accordance with an illustrative embodiment. **Figure 12**
is a front view of a metal bracket showing a new design. Metal bracket **1200** is a
physical implementation of metal bracket **330** of **Figure 3**. Metal bracket **1200** has
first flange **1202** and fastening flange **1204**. As depicted, metal bracket **1200** has z-
20 shaped cross-section **1206**.

As depicted, first flange **1202** is not continuous across the length of metal
bracket **1200**. For example, first flange **1202** has portion **1208**, **1210**, and **1212**.
Metal bracket **1200** in **Figure 12** is not meant to imply physical or architectural
limitations to the manner in which an illustrative embodiment may be implemented.
25 In other implementations, first flange **1202** may be continuous along the length of
metal bracket **1200**. In some illustrative examples, first flange **1202** has greater than
three portions. In other illustrative examples, first flange **1202** has fewer than three
portions.

Turning now to **Figure 13**, an illustration of a side view of a metal bracket is depicted in accordance with an illustrative embodiment. **Figure 13** is a side view of the metal bracket. Holes **1300** of fastening flange **1204** are visible in view **1302**. To fasten metal bracket **1200** to a ceiling within an aircraft, fasteners (not depicted) are sent through holes **1300**.

Turning now to **Figure 14**, an illustration of a top view of a metal bracket is depicted in accordance with an illustrative embodiment. **Figure 14** is a top view of the metal bracket.

Turning now to **Figure 15**, an illustration of a bottom view of a metal bracket is depicted in accordance with an illustrative embodiment. **Figure 15** is a bottom view of the metal bracket. In view **1500**, channel **1206** formed by first flange **1202** and second flange **1204** is visible.

Turning now to **Figure 16**, an illustration of an interior side of an aft wall is depicted in accordance with an illustrative embodiment. Aft wall **1600** is a physical implementation of aft wall **304** of **Figure 3**. View **1601** of aft wall **1600** is an interior view within a lavatory. As depicted, aft wall **1600** is an implementation of an aft wall that is not adjacent an aircraft entry door. For example, aft wall **1600** may be within a lavatory in the center or the rear of the cabin of an aircraft, such as aircraft **2800** of **Figure 28**.

View **1601** of aft wall **1600** is an interior view within a lavatory, such as aircraft modular lavatory monument **100** of **Figure 1**. Aft wall **1600** has common curvature **1602** for curved outboard edge **1604** of aft wall **1600**. Curved outboard edge **1604** is convex and mirrors a concave curvature of an outboard wall (not depicted).

Aft wall **1600** has a plurality of unchangeable connection points. In view **1601**, the plurality of unchangeable connection points comprises metal bracket **1606** bonded to curved outboard edge **1604** of aft wall **1600**. Metal bracket **1606** is used to connect aft wall **1600** to an outboard wall (not depicted).

The plurality of unchangeable connection points comprises floor fittings **1608** on base **1609** of aft wall **1600**. Inboard edge **1610** of aft wall **1600** has a decorative component to provide privacy within a passenger cabin of an aircraft.

5 Aft wall **1600** also includes mirror **1612** and door strike **1614**. Each of mirror **1612** and door frame **1614** are on internal side **1616** of aft wall **1600**. When installed in an aircraft, internal side **1616** faces into a lavatory monument.

Turning now to **Figure 17**, an illustration of an external side of an aft wall is depicted in accordance with an illustrative embodiment. Aft wall **1700** is a physical implementation of aft wall **304** of **Figure 3**. As depicted, aft wall **1700** is an implementation of an aft wall that is not adjacent an aircraft entry door. For example, aft wall **1700** may be within a lavatory in the center or the rear of the cabin of an aircraft, such as aircraft **2800** of **Figure 28**.

As depicted, aft wall **1700** is an implementation of an aft wall of a lavatory that is not adjacent to an aircraft entry door. View **1701** of aft wall **1700** is a view of aft wall **1700** outside of a lavatory. For example, aft wall **1700** may be an implementation of an external side of aft wall **1600** of **Figure 16**. External side **1712** of aft wall **1700** is the side of aft wall **1700** visible to passengers upon entering an aircraft, such as aircraft **2800** of **Figure 28**.

20 Aft wall **1700** has common curvature **1702** for curved outboard edge **1704** of aft wall **1700**. Curved outboard edge **1704** is convex and mirrors a concave curvature of an outboard wall (not depicted).

Aft wall **1700** has a plurality of unchangeable connection points. In view **1701**, the plurality of unchangeable connection points comprises metal bracket **1706** bonded to curved outboard edge **1704** of aft wall **1700**.

25 The plurality of unchangeable connection points comprises floor fittings **1708** on base **1709** of aft wall **1700**. Inboard edge **1710** of aft wall **1700** has a decorative component to provide privacy within a passenger cabin of an aircraft.

For simplicity, a plurality of common interface points is not depicted on external side **1712** of aft wall **1700**. However, a plurality of common interface points would be present on external side **1712** of aft wall **1700** to connect a plurality of non-lavatory features to external side **1712** of aft wall **1700**.

5 In some illustrative embodiments, aft wall **1700** is provisioned for a large number of interfaces, including attendant seats. It is desirable for aft walls, such as aft wall **1700**, to be designed in terms of shape and materials to hold high loads due to attendant seats and other equipment interfaces. In some illustrative examples, aft wall **1700** has imbedded foam kits and metal details to deal with wire pass throughs
10 and attendant seat mounting.

Each component of the plurality of non-lavatory features connected to aft wall **1700** of **Figure 17** are removeable and replaceable due to a plurality of common interface points. Each component connected to aft wall is connected using the plurality of common interface points.

15 Turning now to **Figure 18**, an illustration of a bottom edge of an aft wall configured to be joined to a floor of a lavatory monument is depicted in accordance with an illustrative embodiment. View **1800** is a bottom view of aft wall **1700** of **Figure 17**. In view **1800**, floor fitting **1802** and floor fitting **1804** of floor fittings **1708** are visible. Floor fitting **1802** and floor fitting **1804** are unchangeable connection
20 points to removably connect aft wall **1700** to a floor. Aft wall **1700** also comprises assist handle **1806** on internal side **1808** of aft wall **1700**. In view **1800**, metal bracket **1706** bonded to curved outboard edge **1704** of aft wall **1700** is visible.

Turning now to **Figure 19**, an illustration of a side view of a metal bracket bonded to a curved outboard edge of an aft wall configured to be joined to an
25 outboard wall of a lavatory monument is depicted in accordance with an illustrative embodiment. View **1900** is a view of curved outboard edge **1704** of aft wall **1700** of **Figures 17-18**. Metal bracket **1706** is bonded to curved outboard edge **1704** and covers a substantial portion of curved outboard edge **1704**.

Turning now to **Figure 20**, an illustration of a cross-sectional view of a metal bracket bonded to a curved outboard edge of an aft wall configured to be joined to an outboard wall of a lavatory monument is depicted in accordance with an illustrative embodiment. View **2000** is a cross-sectional view of metal bracket **1706**
5 bonded to curved outboard edge **1704** of aft wall **1700**.

Metal bracket **1706** has first flange **2002** and second flange **2004** forming channel **2006**. First flange **2002** contacts internal side **2008** of aft wall **1700**. Second flange **2004** contacts external side **2010** of aft wall **1700**.

Metal bracket **1706** has fastening flange **2012**. Fastening flange **2012** is
10 perpendicular to first flange **2002** and second flange **2004**. Fastening flange **2012** has holes **2014**. To connect aft wall **1700** to an outboard wall (not depicted), fasteners (not depicted) are sent through fastening flange **2012**. As depicted, metal bracket **1706** has F-shaped cross-section **2016**.

The illustrative examples provide an ornamental design for a metal bracket for
15 an aft wall of an aircraft lavatory monument. Each of **Figures 21-24** provide views of the metal bracket of this design.

Turning now to **Figure 21**, an illustration of a perspective view of a front of a metal bracket is depicted in accordance with an illustrative embodiment. **Figure 21** is a front view of a metal bracket showing a new design. Metal bracket **2100** is a
20 physical implementation of metal bracket **330** of **Figure 3**. Metal bracket **2100** has first flange **2102** and second flange **2104** forming channel **2106**. Metal bracket **2100** also has fastening flange **2108**. As depicted, metal bracket **2100** has F-shaped cross-section **2110**.

Turning now to **Figure 22**, an illustration of a top view of a metal bracket is
25 depicted in accordance with an illustrative embodiment. **Figure 22** is a top view of the metal bracket. **Figure 22** is a top view of the metal bracket. Holes **2200** of fastening flange **2108** are visible in view **2202**. To fasten metal bracket **2100** to an

outboard wall within an aircraft, fasteners (not depicted) are sent through holes **2200**.

Turning now to **Figure 23**, an illustration of a bottom view of a metal bracket is depicted in accordance with an illustrative embodiment. **Figure 23** is a bottom view of the metal bracket. In view **2300**, channel **2106** formed by first flange **2102** and second flange **2104** is visible.

Turning now to **Figure 24**, an illustration of a back view of a metal bracket is depicted in accordance with an illustrative embodiment. **Figure 24** is a back view of the metal bracket.

Other options, styles, and arrangements are also possible. The illustrative examples shown in **Figures 4** and **24** are not meant to imply physical or architectural limitations to the manner in which an illustrative embodiment may be implemented.

Turning now to **Figure 25**, a flowchart of a method for constructing a lavatory monument in an aircraft, the lavatory monument having interchangeable sub-assemblies, is presented in accordance with an illustrative embodiment. Method **2500** may be implemented in an aircraft, such as aircraft **300** of **Figure 3** and aircraft **2800** of **Figure 28**. Method **2500** may be used to install any of aft wall **400** of **Figure 4**, aft wall **500** of **Figure 5**, aft wall **600** of **Figure 6**, aft wall **1600** of **Figure 16**, or aft wall **1700** of **Figure 17** in an aircraft.

The interchangeable sub-assemblies of the lavatory monument include at least one of any desirable lavatory fixtures, or any desirable non-lavatory features, or modules comprising any combination of at least one of lavatory fixtures or non-lavatory features. The lavatory monument comprises a plurality of sub-assemblies that are removably connected to a given lavatory fixture such that removal and replacement of one of the plurality of sub-assemblies does not require removal of any other of the plurality of sub-assemblies. In one illustrative example, a sub-assembly comprises a backsplash, a faucet, and a liquid hose line. In this illustrative

example, the sub-assembly may be installed and removed from the lavatory without removing any other sub-assemblies.

Method **2500** bonds a metal bracket to a curved outboard edge of an aft wall (operation **2502**). Method **2500** joins the metal bracket to an outboard wall of the lavatory monument using a plurality of fasteners (operation **2504**). Method **2500** 5 removably connects the aft wall to a ceiling and a floor of the lavatory monument (operation **2506**). Afterwards, method **2500** terminates.

In some illustrative examples, method **2500** removably connects a plurality of non-lavatory features to a plurality of common interface points of the aft wall, the 10 plurality of non-lavatory features comprises at least one of an attendant seat, cabinetry, a display screen, or a user interface (operation **2508**). The plurality of non-lavatory features may be removed and replaced. In some illustrative examples, a non-lavatory feature may be removed to install a different non-lavatory feature having a different design. In some illustrative examples, a non-lavatory feature is 15 removed for replacement during maintenance.

Turning now to **Figure 26**, a flowchart of a method for of performing maintenance on a lavatory monument in an aircraft, the lavatory monument having interchangeable sub-assemblies is presented in accordance with an illustrative embodiment. Method **2600** may be implemented in an aircraft, such as aircraft **300** 20 of **Figure 3** and aircraft **2800** of **Figure 28**. Method **2600** may be used to remove any of aft wall **400** of **Figure 4**, aft wall **500** of **Figure 5**, aft wall **600** of **Figure 6**, aft wall **1600** of **Figure 16**, or aft wall **1700** of **Figure 17** in an aircraft.

Methods **2600** removes an interchangeable sub-assembly from the lavatory monument, wherein the interchangeable sub-assembly is removably connected to 25 the lavatory monument (operation **2602**). Method **2600** removably connects a new interchangeable sub-assembly to the lavatory monument (operation **2604**). Afterwards, method **2600** terminates.

In some illustrative examples, the interchangeable sub-assembly is an aft wall of the lavatory monument, and wherein removing the interchangeable sub-assembly comprises releasing the aft wall at unchangeable connection points between the aft wall and an outboard wall, a ceiling, and a floor of the lavatory monument (operation **2606**). In some illustrative examples, the new interchangeable sub-assembly is an aft wall having a different design than the aft wall removed from the lavatory monument (operation **2608**). By having a different design, the new aft wall may have different common interface points, different non-lavatory features connected, or any other desirable differences. In some illustrative examples, the new aft wall may have a same design as the removed aft wall. In these illustrative examples, the aft wall is removed for maintenance due to wear and replaced with the new aft wall having the same design.

In some illustrative examples, the interchangeable sub-assembly comprises a non-lavatory feature removably connected to at least one common interface point of an aft wall of the aircraft, and wherein removing the interchangeable sub-assembly comprises releasing the non-lavatory feature from the aft wall at the at least one common interface point (operation **2610**). In some illustrative examples, the new interchangeable sub-assembly is a non-lavatory feature having a different design than the non-lavatory feature removed from the aft wall (operation **2612**). By having a different design, the new non-lavatory feature may have a different function, a different aesthetic, or any other desirable differences. In some illustrative examples, the new non-lavatory feature may have a same design as the removed non-lavatory feature. In these illustrative examples, the non-lavatory feature is removed for maintenance due to wear and replaced with the new non-lavatory feature having the same design.

Still other variations are possible. More or fewer operations may be present, or different operations may be present. The flowcharts and block diagrams in the different depicted embodiments illustrate the architecture, functionality, and operation of some possible implementations of apparatus and methods in an

illustrative embodiment. In this regard, each block in the flowcharts or block diagrams may represent a module, a segment, a function, and/or a portion of an operation or step.

5 In some alternative implementations of an illustrative embodiment, the function or functions noted in the blocks may occur out of the order noted in the figures. For example, in some cases, two blocks shown in succession may be executed substantially concurrently, or the blocks may sometimes be performed in the reverse order, depending upon the functionality involved. Also, other blocks may be added, in addition to the illustrated blocks, in a flowchart or block diagram. In
10 some illustrative examples, not all blocks are performed and some blocks may be optional, in a flowchart or block diagram. For example, operation **2508** may be optional.

Figure 27 is an illustration of an aircraft manufacturing and service method in the form of a block diagram, in accordance with an illustrative embodiment. **Figure**
15 **28** is an illustration of an aircraft in the form of a block diagram, in accordance with an illustrative embodiment.

Illustrative embodiments of the disclosure may be described in the context of aircraft manufacturing and service method **2700** as shown in **Figure 27** and aircraft **2800** as shown in **Figure 28**. Turning first to **Figure 27**, an illustration of an aircraft
20 manufacturing and service method is depicted in accordance with an illustrative embodiment. During pre-production, aircraft manufacturing and service method **2700** may include specification and design **2702** of aircraft **2800** in **Figure 28** and material procurement **2704**.

During production, component and subassembly manufacturing **2706** and
25 system integration **2708** of aircraft **2800** in **Figure 28** takes place. Thereafter, aircraft **2800** in **Figure 28** may go through certification and delivery **2710** in order to be placed in service **2712**. While in service **2712** by a customer, aircraft **2800** in **Figure 28** is scheduled for routine maintenance and service **2714**, which may

include modification, reconfiguration, refurbishment, and other maintenance or service.

Each of the processes of aircraft manufacturing and service method **2700** may be performed or carried out by a system integrator, a third party, and/or an operator. In these examples, the operator may be a customer. For the purposes of this description, a system integrator may include, without limitation, any number of aircraft manufacturers and major-system subcontractors; a third party may include, without limitation, any number of vendors, subcontractors, and suppliers; and an operator may be an airline, a leasing company, a military entity, a service organization, and so on.

With reference now to **Figure 28**, an illustration of an aircraft is depicted in which an illustrative embodiment may be implemented. In this example, aircraft **2800** is produced by aircraft manufacturing and service method **2700** in **Figure 27** and may include airframe **2802** with plurality of systems **2804** and interior **2806**. Examples of systems **2804** include one or more of propulsion system **2808**, electrical system **2810**, hydraulic system **2812**, and environmental system **2814**. Any number of other systems may be included. Although an aerospace example is shown, different illustrative embodiments may be applied to other industries, such as the automotive industry.

Apparatuses and methods embodied herein may be employed during at least one of the stages of aircraft manufacturing and service method **2700** in **Figure 27**. One or more apparatus embodiments, method embodiments, or a combination thereof may be utilized during production stages, such as component and subassembly manufacturing **2706** and system integration **2708** in **Figure 27**. In one illustrative example, components of an aircraft modular lavatory monument, such as lavatory monument **306**, may be produced and assembled in component and subassembly manufacturing **2706** in **Figure 27**.

Further, the disclosure comprises embodiments according to the following clauses:

Clause 1. An aircraft (300) comprising:

a fuselage (302); and

5 an aft wall (304) of a lavatory monument (306) within the fuselage (302) and extending radially inwardly relative to the fuselage (302), the aft wall (304) removably connected to an outboard wall (308), a ceiling (310), and a floor (312) of the lavatory monument (306).

10 Clause 2. The aircraft (300) of clause 1, the aft wall (304) has unchangeable connection points (318) configured to join the aft wall (304) to the outboard wall (308), the ceiling (310), and the floor (312) of the lavatory monument (306).

Clause 3. The aircraft (300) of clause 2 further comprising:

15 the outboard wall (308) connected to an inside surface (320) of the fuselage (302).

Clause 4. The aircraft (300) of Clause 2, wherein the aft wall (304) has a common curvature (322) for a curved outboard edge (324) of the aft wall (304),
20 wherein the curved outboard edge (324) is convex (326) and mirrors a concave curvature (328) of the outboard wall (308).

Clause 5. The aircraft (300) of clause 4, wherein the unchangeable connection points (318) comprise a metal bracket (330) bonded to the curved outboard edge
25 (324) of the aft wall (304).

Clause 6. The aircraft (300) of clause 5 further comprising:

fasteners (332) joining the metal bracket (330) to the outboard wall (308), wherein the fasteners (332) are not visible to a passenger outside of the lavatory monument (306).

5

Clause 7. The aircraft (300) of clause 5, wherein the metal bracket (330) comprises a first flange (334) and a second flange (336) forming a channel (338), wherein the curved outboard edge (324) is positioned within the channel (338) of the metal bracket (330).

10

Clause 8. The aircraft (300) of clause 7, wherein the first flange (334) of the metal bracket (330) contacts an internal side (340) of the aft wall (304), and wherein the second flange (336) of the metal bracket (330) contacts an external side (342) of the aft wall (304).

15

Clause 9. The aircraft (300) of any preceding clause, wherein the aft wall (304) has a plurality of common interface points (314) for joining a plurality of non-lavatory features (316) to the aft wall (304).

20

Clause 10. The aircraft (300) of clause 9 further comprising:

the plurality of non-lavatory features (316), wherein the plurality of non-lavatory features (316) comprises at least one of an attendant seat, cabinetry, a display screen, or a user interface.

Clause 11. An aft wall (304) configured to be removably connected to an outboard wall (308), a ceiling (310), and a floor (312) of a lavatory monument (306), the aft wall (304) comprising:

a curved outboard edge (324) having a common curvature (322); and

5 a metal bracket (330) bonded to the curved outboard edge (324), the metal bracket (330) configured to removably connect the aft wall (304) to the outboard wall (308).

Clause 12. The aft wall (304) of clause 11, further comprising:

10 a plurality of common interface points (314) for joining a plurality of non-lavatory features (316) to the aft wall (304).

Clause 13. The aft wall (304) of any one of clauses 11-12, wherein the aft wall (304) has unchangeable connection points (318) configured to join the aft wall (304)
15 to the outboard wall (308), the ceiling (310), and the floor (312) of the lavatory monument (306).

Clause 14. The aft wall (304) of any one of clauses 11-13, wherein the curved outboard edge (324) is convex (326) and mirrors a concave curvature (328) of an
20 outboard wall (308).

Clause 15. The aft wall (304) of any one of clauses 11-14, wherein the metal bracket (330) comprises a first flange (334) and a second flange (336) forming a channel (338), wherein the curved outboard edge (324) is positioned within the
25 channel (338) of the metal bracket (330).

Clause 16. The aft wall (304) of clause 15, wherein the first flange (334) of the metal bracket (330) contacts an internal side (340) of the aft wall (304), and wherein the second flange (336) of the metal bracket (330) contacts an external side (342) of the aft wall (304).

5

Clause 17. The aft wall (304) of clause 16, wherein the metal bracket (330) further comprises a fastening flange (344), wherein the first flange (334), second flange (336), and fastening flange (344) form a F-shaped cross-section (346).

10 Clause 18. The aft wall (304) of clause 11, wherein the aft wall (304) further comprises aircraft (300) door flaps configured to allow aircraft door snubbers to pass through the aft wall (304).

15 Clause 19. A method (2500) of constructing a lavatory monument (306) in an aircraft (300), the lavatory monument (306) having interchangeable sub-assemblies, the method comprising:

bonding (2502) a metal bracket (330) to a curved outboard edge (324) of an aft wall (304);

20 joining (2504) the metal bracket (330) to an outboard wall (308) of the lavatory monument (306) using a plurality of fasteners (332); and

removably (2506) connecting the aft wall (304) to a ceiling (310) and a floor (312) of the lavatory monument (306).

Clause 20. The method (2500) of clause 19 further comprising:

25 removably (2508) connecting a plurality of non-lavatory features (316) to a plurality of common interface points (314) of the aft wall (304), the plurality of non-

lavatory features (316) comprises at least one of an attendant seat, cabinetry, a display screen, or a user interface.

5 Clause 21. A method (2600) of performing maintenance on a lavatory monument (306) in an aircraft (300), the lavatory monument (306) having interchangeable sub-assemblies, the method comprising:

removing (2602) an interchangeable sub-assembly from the lavatory monument (306), wherein the interchangeable sub-assembly is removably connected to the lavatory monument (306); and

10 removably (2604) connecting a new interchangeable sub-assembly to the lavatory monument (306).

Clause 22. The method (2600) of clause 21, wherein (2606) the interchangeable sub-assembly is an aft wall (304) of the lavatory monument (306), and wherein
15 removing the interchangeable sub-assembly comprises releasing the aft wall (304) at unchangeable connection points (318) between the aft wall (304) and an outboard wall (308), a ceiling (310), and a floor (312) of the lavatory monument (306).

Clause 23. The method (2600) of clause 22, wherein (2608) the new
20 interchangeable sub-assembly is an aft wall (304) having a different design than the aft wall (304) removed from the lavatory monument (306).

Clause 24. The method (2600) of any one of clauses 21-23, wherein (2610) the
25 interchangeable sub-assembly comprises a non-lavatory feature removably connected to at least one common interface point of an aft wall (304) of the aircraft (300), and wherein removing the interchangeable sub-assembly comprises releasing

the non-lavatory feature from the aft wall (304) at the at least one common interface point.

5 Clause 25. The method (2600) of clause 24, wherein (2612) the new interchangeable sub-assembly is a non-lavatory feature having a different design than the non-lavatory feature removed from the aft wall (304).

10 One or more apparatus embodiments, method embodiments, or a combination thereof may be utilized while aircraft 2800 is in service 2712 and/or during maintenance and service 2714 in Figure 27. For example, one or more non-lavatory features of plurality of non-lavatory features of an aft wall of an aircraft modular lavatory monument, such as aft wall 304 of lavatory monument 306, may be at least one of removed or replaced during maintenance and service 2714 in Figure 27. The use of a number of the different illustrative embodiments may substantially expedite
15 the assembly of and/or reduce the cost of aircraft 2800.

20 The description of the different illustrative embodiments has been presented for purposes of illustration and description, and is not intended to be exhaustive or limited to the embodiments in the form disclosed. Many modifications and variations will be apparent to those of ordinary skill in the art. Further, different illustrative embodiments may provide different features as compared to other illustrative
25 embodiments. The embodiment or embodiments selected are chosen and described in order to best explain the principles of the embodiments, the practical application, and to enable others of ordinary skill in the art to understand the disclosure for various embodiments with various modifications as are suited to the particular use contemplated.

EMBODIMENTS IN WHICH AN EXCLUSIVE PROPERTY OR PRIVILEGE IS CLAIMED ARE DEFINED AS FOLLOWS:

1. An aircraft that comprises:

5 a fuselage that comprises therein a lavatory monument, wherein the lavatory monument comprises an aft wall, wherein the aft wall is configured to be removably connected to an outboard wall of the lavatory monument, and wherein the aft wall comprises:

an outboard edge that curves radially inwardly relative to the fuselage;

10 a bracket bonded to the outboard edge, wherein the bracket covers a portion of the outboard edge; and

fasteners configured to removably connect the bracket to the outboard wall.

15 2. The aircraft of claim 1, wherein the aft wall has unchangeable connection points configured to join the aft wall to the outboard wall, a ceiling, and a floor of the lavatory monument.

3. The aircraft of claim 1 or 2, wherein the outboard wall is connected to an inside surface of the fuselage.

20 4. The aircraft of any one of claims 1 to 3, wherein the aft wall has a common curvature for the outboard edge, wherein the outboard edge is convex and mirrors a concave curvature of the outboard wall.

5. The aircraft of any one of claims 1 to 4, wherein the aft wall is configured such that the fasteners are not visible to a passenger outside of the lavatory monument.

6. The aircraft of any one of claims 1 to 5, wherein the bracket comprises a first flange and a second flange forming a channel, wherein the outboard edge is positioned within the channel of the bracket.
- 5 7. The aircraft of claim 6, wherein the first flange of the bracket contacts an internal side of the aft wall, and wherein the second flange of the bracket contacts an external side of the aft wall.
8. The aircraft of any one of claims 1 to 7, wherein the aft wall has a plurality of common interface points for joining a plurality of non-lavatory features to the aft wall.
- 10 9. The aircraft of claim 8, wherein the plurality of non-lavatory features comprises one or more of an attendant seat, cabinetry, a display screen, and a user interface.
10. An aft wall installed in an aircraft and configured to be removably connected to an outboard wall of a lavatory monument, wherein the aft wall comprises:
 - 15 a curved outboard edge having a common curvature;
 - a bracket bonded to the curved outboard edge, wherein the bracket covers a portion of the curved outboard edge; and
 - fasteners configured to removably connect the bracket to the outboard wall.
- 20 11. The aft wall of claim 10, further comprising:
 - a plurality of common interface points for joining a plurality of non-lavatory features to the aft wall.

12. The aft wall of claim **10** or **11**, wherein the aft wall has unchangeable connection points configured to join the aft wall to the outboard wall, a ceiling, and a floor of the lavatory monument.
- 5 13. The aft wall of any one of claims **10** to **12**, wherein the curved outboard edge is convex and mirrors a concave curvature of the outboard wall.
14. The aft wall of any one of claims **10** to **13**, wherein the bracket comprises a first flange and a second flange forming a channel, wherein the curved outboard edge is positioned within the channel of the bracket.
- 10 15. The aft wall of claim **14**, wherein the first flange of the bracket contacts an internal side of the aft wall, and wherein the second flange of the bracket contacts an external side of the aft wall.
16. The aft wall of claim **14** or **15**, wherein the bracket further comprises a fastening flange, wherein the first flange, the second flange, and the fastening flange form a F-shaped cross-section.
- 15 17. The aft wall of any one of claims **10** to **13**, wherein the bracket has a z-shaped cross-section and comprises:
- a first flange in contact with an internal side of the aft wall; and
 - a fastening flange extending upward from the aft wall and configured to be removably fastened to the outboard wall with the fasteners.
- 20 18. A method of constructing a lavatory monument in an aircraft, the lavatory monument having interchangeable sub-assemblies, the method comprising:
- bonding a bracket to a curved outboard edge of an aft wall, wherein the bracket covers a portion of the curved outboard edge;

joining the bracket to an outboard wall of the lavatory monument using a plurality of fasteners; and

removably connecting the aft wall to a ceiling and a floor of the lavatory monument.

5 **19.** The method of claim **18** further comprising:

removably connecting a plurality of non-lavatory features to a plurality of common interface points of the aft wall, wherein the plurality of non-lavatory features comprises one or more of an attendant seat, cabinetry, a display screen, and a user interface.

10 **20.** A method of performing maintenance on a lavatory monument in an aircraft, the lavatory monument having interchangeable sub-assemblies, the method comprising:

15 removing an existing interchangeable sub-assembly from the lavatory monument, wherein the existing interchangeable sub-assembly is removably connected to the lavatory monument and wherein the existing interchangeable sub-assembly is an existing aft wall of the lavatory monument; and

20 removably connecting a new interchangeable sub-assembly to the lavatory monument, wherein the new interchangeable sub-assembly is a new aft wall of the lavatory monument configured to be removably connected to an outboard wall, a ceiling, and a floor of the lavatory monument and the new aft wall comprises:

 a curved outboard edge having a common curvature;

a bracket bonded to the curved outboard edge, wherein the bracket covers a less than whole portion of the curved outboard edge; and

fasteners configured to removably connect the bracket to the outboard wall.

5

21. The method of claim **20**, wherein removing the existing interchangeable sub-assembly comprises releasing the existing aft wall at unchangeable connection points between the existing aft wall and the outboard wall, the ceiling, and the floor of the lavatory monument.

10 **22.** The method of claim **20** or **21**, wherein the new aft wall has a different design than the existing aft wall removed from the lavatory monument.

23. The method of any one of claims **20** to **22**, wherein the existing interchangeable sub-assembly further comprises an existing non-lavatory feature removably connected to at least one common interface point of the existing aft wall of the lavatory monument, and wherein removing the existing interchangeable sub-assembly comprises releasing the existing non-lavatory feature from the existing aft wall of the lavatory monument at the at least one common interface point.

15

24. The method of claim **23**, wherein the new interchangeable sub-assembly comprises a new non-lavatory feature having a different design than the existing non-lavatory feature removed from the existing aft wall of the lavatory monument.

20

25. An aircraft comprising:

a fuselage that comprises therein a lavatory monument, wherein the lavatory monument comprises an aft wall extending radially inwardly relative to the fuselage, wherein:

25

the aft wall is configured to be removably connected to an outboard wall, a ceiling, and a floor of the lavatory monument;

5

the aft wall has unchangeable connection points configured to join the aft wall to the outboard wall, the ceiling, and the floor of the lavatory monument;

the aft wall has an outboard edge having a common curvature which mirrors a concave curvature of the outboard wall;

10

the unchangeable connection points comprise a metal bracket bonded to the outboard edge to removably connect the aft wall to the outboard wall; and

the metal bracket comprises a first flange and a second flange forming a channel, wherein the outboard edge is positioned within the channel of the metal bracket.

15

26. The aircraft of claim **25**, wherein the outboard wall is connected to an inside surface of the fuselage.

27. The aircraft of claim **25** or **26** further comprising:

fasteners joining the metal bracket to the outboard wall, wherein the fasteners are not visible to a passenger outside of the lavatory monument.

20

28. The aircraft of any one of claims **25** to **27**, wherein the first flange of the metal bracket contacts an internal side of the aft wall, and wherein the second flange of the metal bracket contacts an external side of the aft wall.

25

29. The aircraft of any one of claims **25** to **28**, wherein the aft wall has a plurality of common interface points for joining a plurality of non-lavatory features to the aft wall.

- 30.** The aircraft of claim **29**, wherein the plurality of non-lavatory features comprises one or more of an attendant seat, cabinetry, a display screen, and a user interface.
- 31.** The aircraft of any one of claims **25** to **30**, wherein the metal bracket is bonded to the outboard edge using a two-part epoxy.
- 32.** The aircraft of any one of claims **25** to **31**, wherein the metal bracket has an F-shaped cross-section.
- 33.** The aircraft of any one of claims **25** to **31**, wherein the metal bracket has a z-shaped cross-section.
- 34.** The aircraft of any one of claims **25** to **31**, wherein the metal bracket has an h-shaped cross-section.
- 35.** A method of performing maintenance on a lavatory monument in an aircraft, the lavatory monument having interchangeable sub-assemblies, the method comprising:
- removing an existing interchangeable sub-assembly from the lavatory monument, wherein the existing interchangeable sub-assembly is removably connected to the lavatory monument and comprises an existing aft wall of the lavatory monument, and wherein removing the existing aft wall comprises:
 - releasing the existing aft wall at unchangeable connection points between the existing aft wall and an outboard wall, a ceiling, and a floor of the lavatory monument, wherein:
 - the existing aft wall has a common curvature for an outboard edge of the existing aft wall and the outboard

edge is convex and mirrors a concave curvature of the outboard wall;

5

the unchangeable connection points comprise a metal bracket bonded to the outboard edge to removably connect the existing aft wall to the outboard wall; and

the metal bracket comprises a first flange and a second flange forming a channel, wherein the outboard edge is positioned within the channel of the metal bracket; and

10

removably connecting a new interchangeable sub-assembly to the lavatory monument, wherein the new interchangeable sub-assembly comprises a new aft wall of the lavatory monument.

36. The method of claim **35**, wherein the new aft wall has a different design than the existing aft wall removed from the lavatory monument.

15

37. The method of claim **35** or **36**, wherein the existing interchangeable sub-assembly further comprises an existing non-lavatory feature removably connected to at least one common interface point of the existing aft wall, and wherein removing the existing interchangeable sub-assembly comprises releasing the existing non-lavatory feature from the existing aft wall at the at least one common interface point.

20

38. The method of claim **37**, wherein the new interchangeable sub-assembly further comprises a new non-lavatory feature having a different design than the existing non-lavatory feature removed from the existing aft wall.

39. The method of any one of claims **35** to **38**, wherein the metal bracket is bonded to the outboard edge using a two-part epoxy.

- 40.** The method of any one of claims **35 to 39**, wherein the metal bracket has an F-shaped cross-section.
- 41.** The method of any one of claims **35 to 39**, wherein the metal bracket has a z-shaped cross-section.
- 5 42.** The method of any one of claims **35 to 39**, wherein the metal bracket has an h-shaped cross-section.

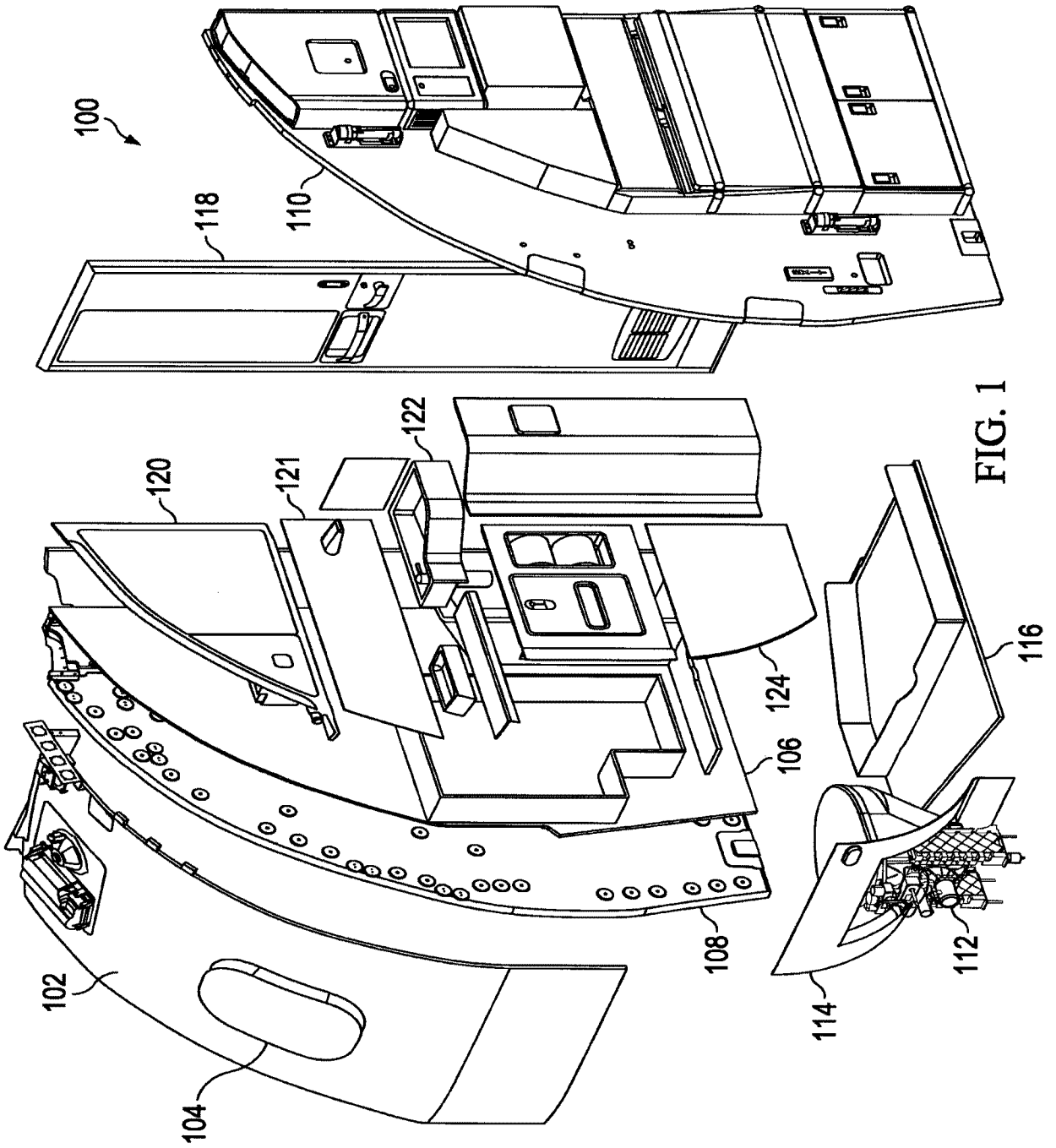

FIG. 1

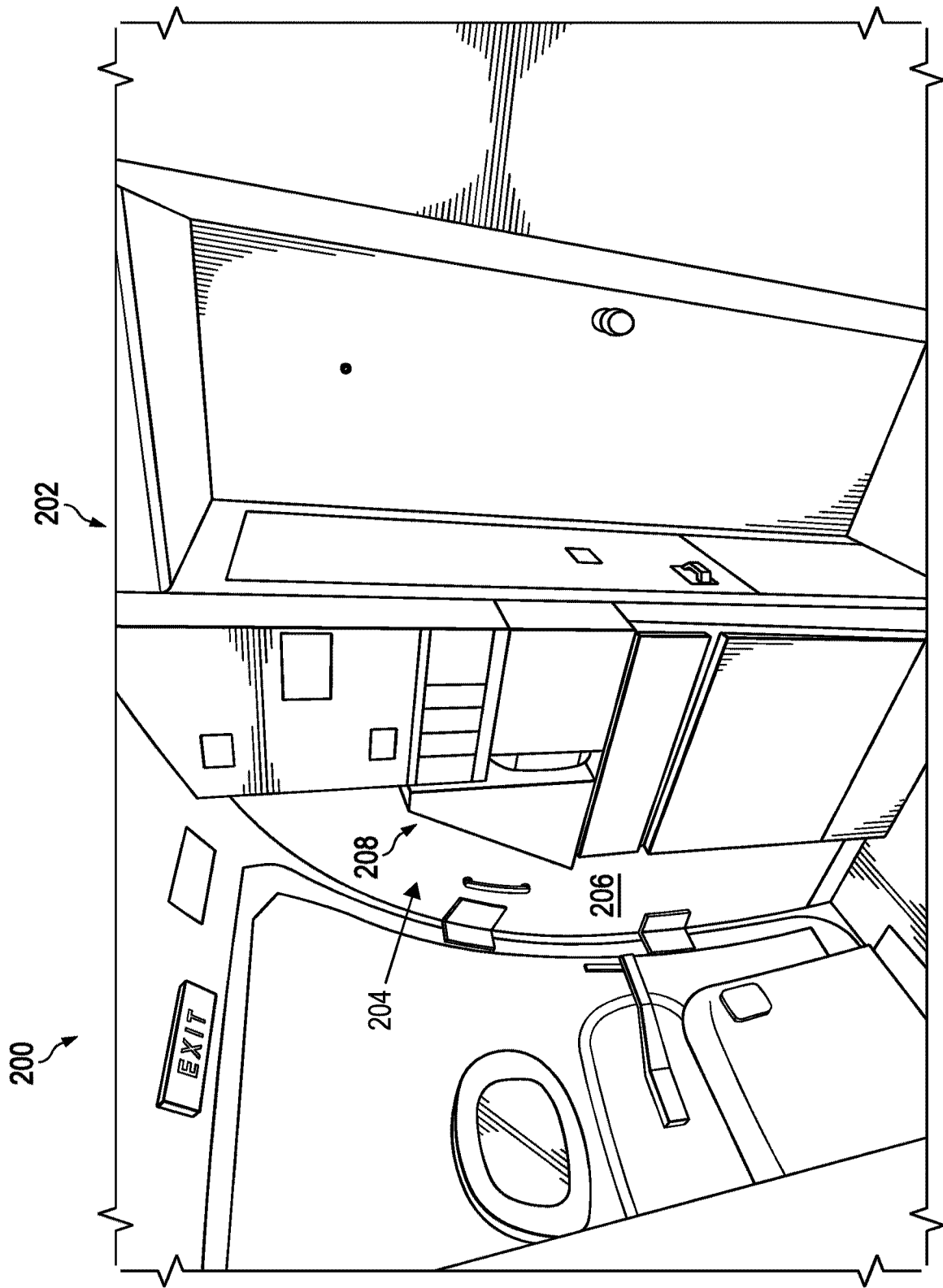

FIG. 2

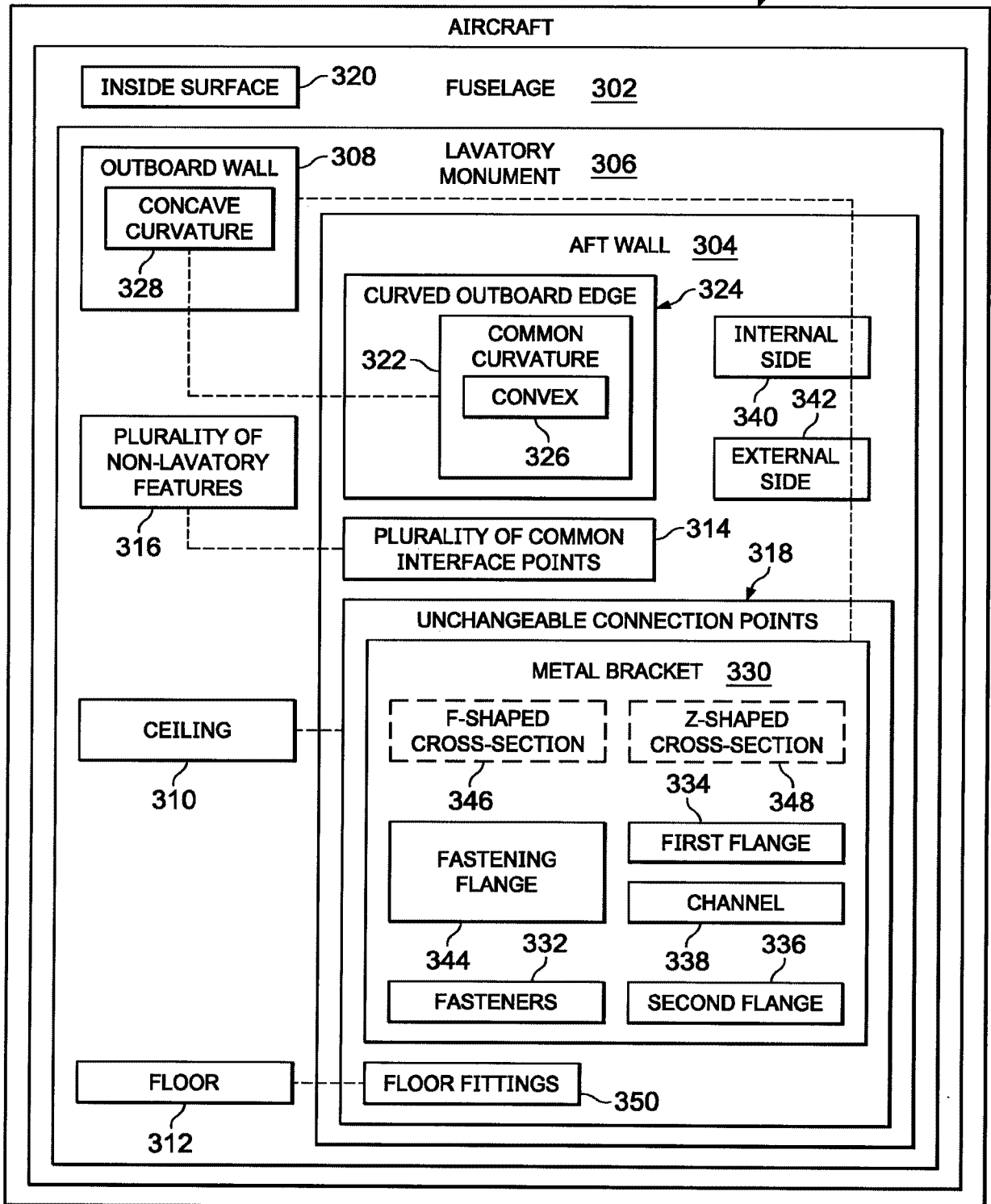

FIG. 3

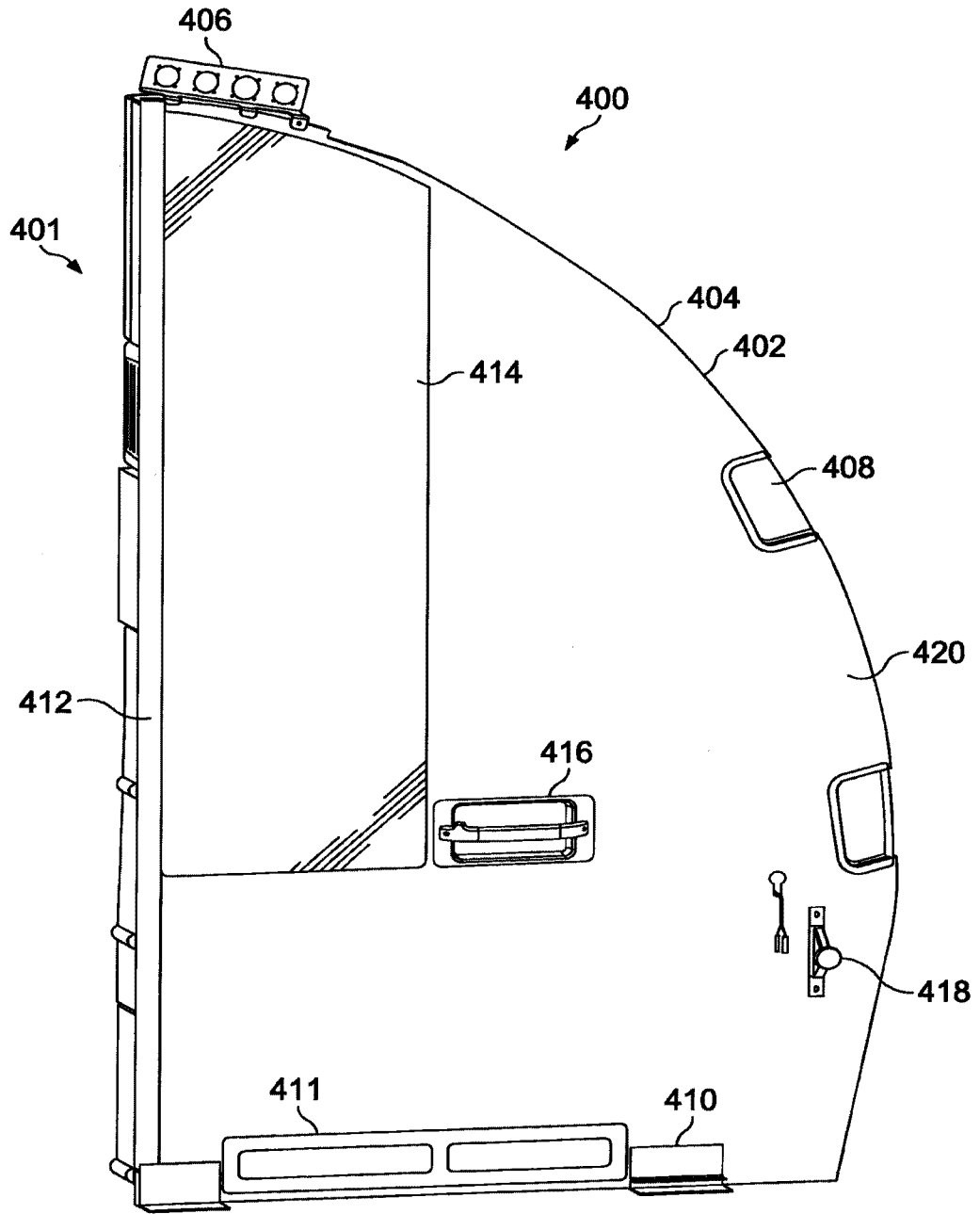

FIG. 4

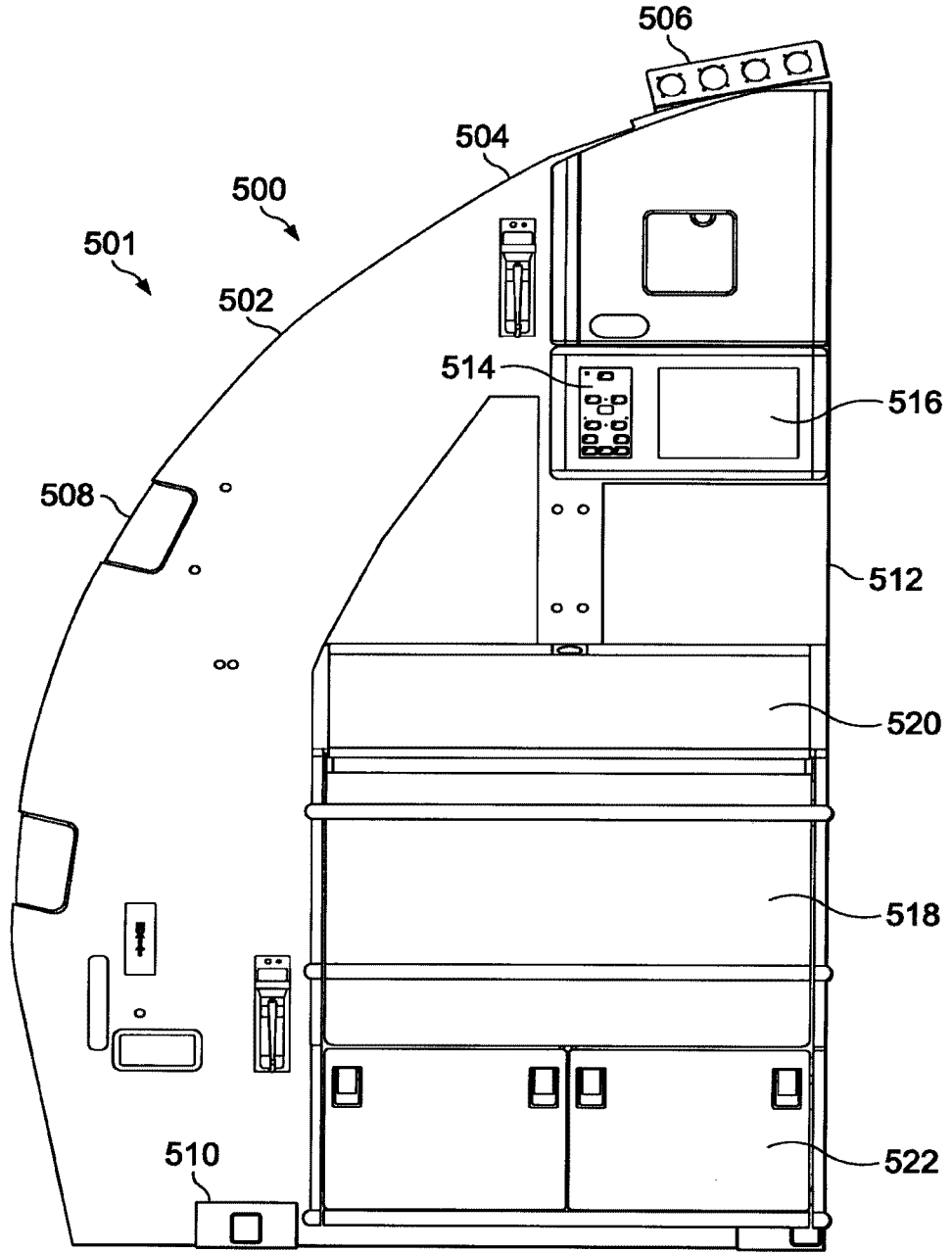

FIG. 5

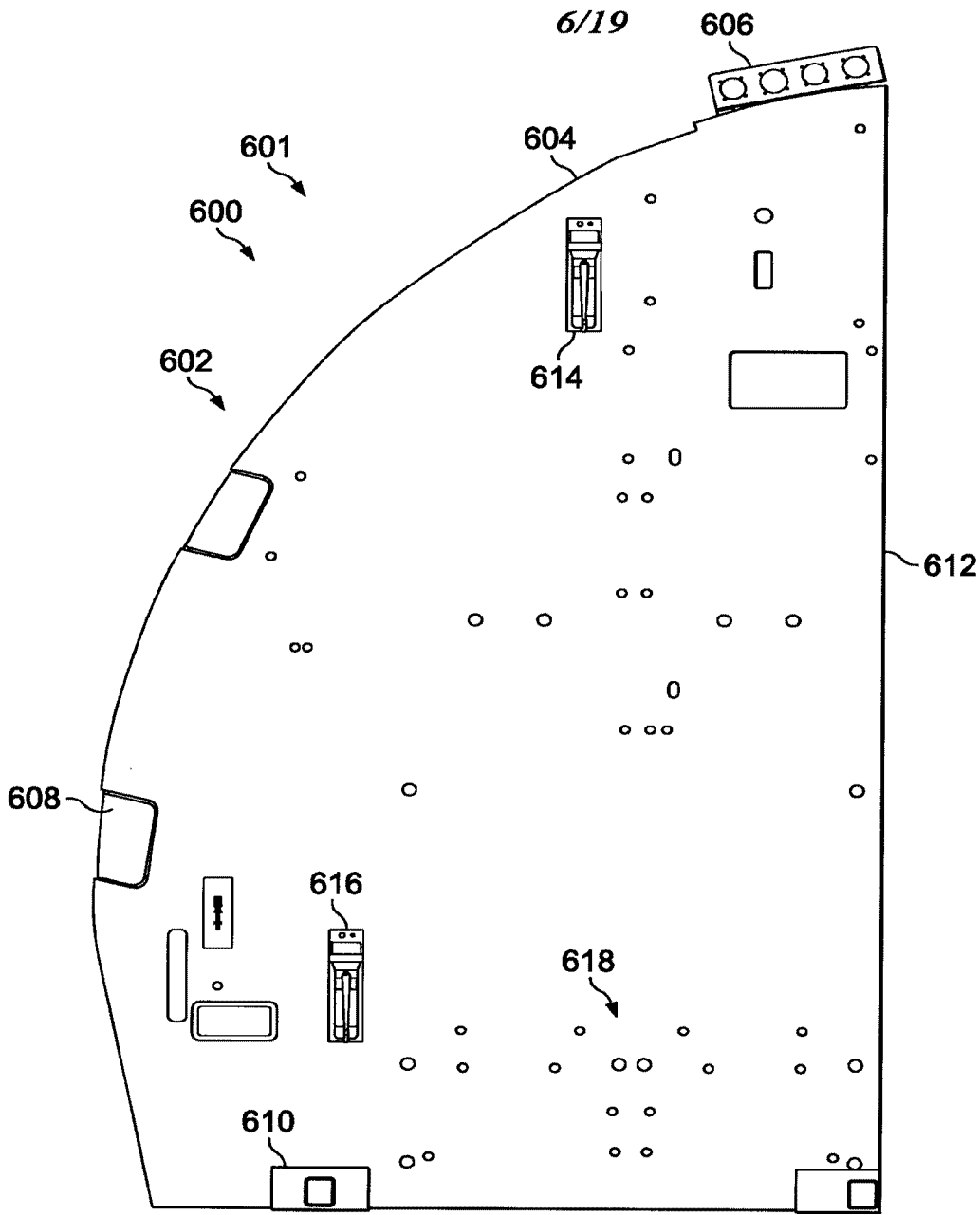

FIG. 6

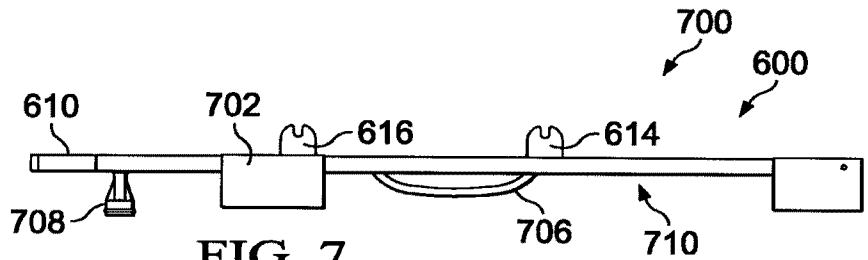

FIG. 7

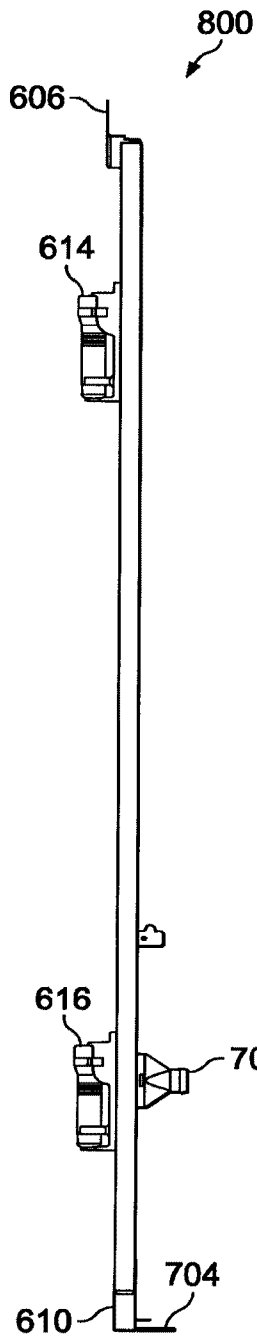

FIG. 8

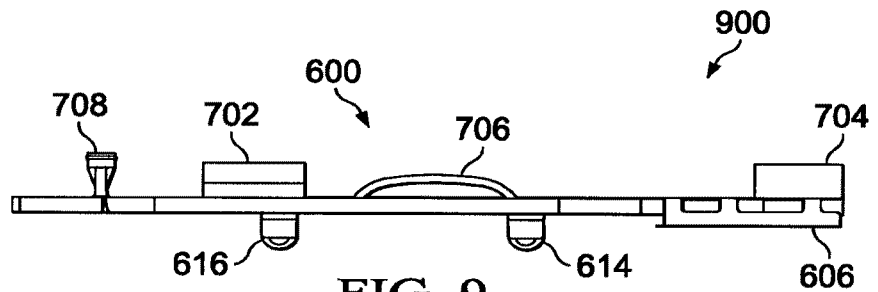

FIG. 9

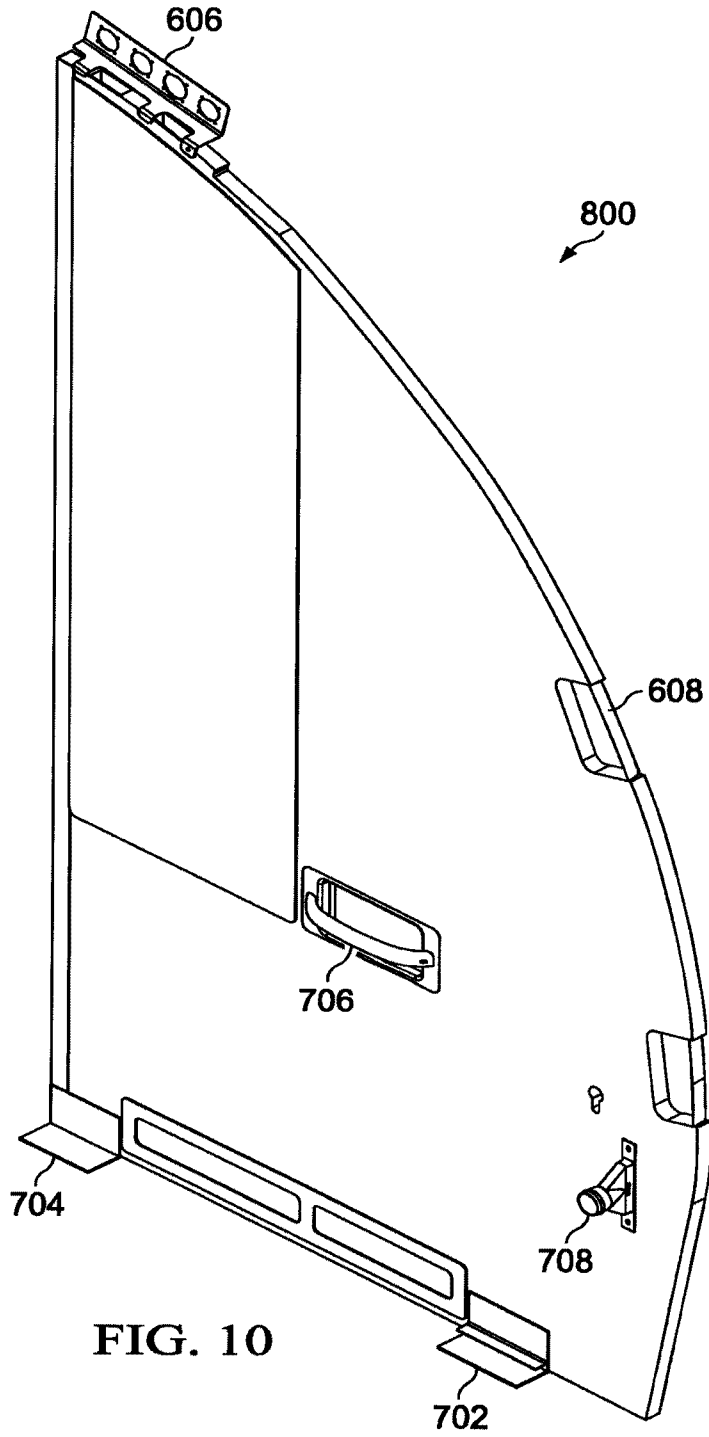

FIG. 10

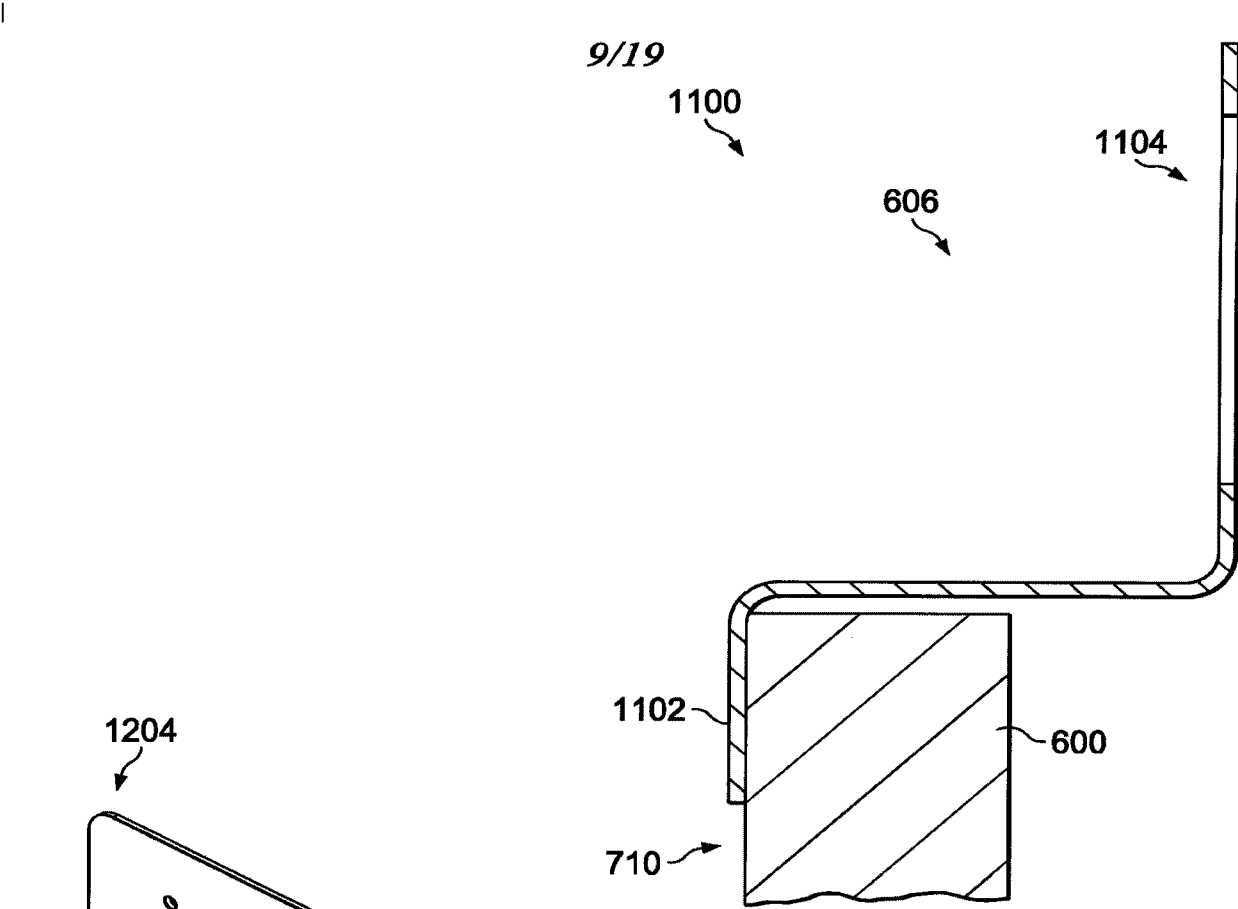

FIG. 11

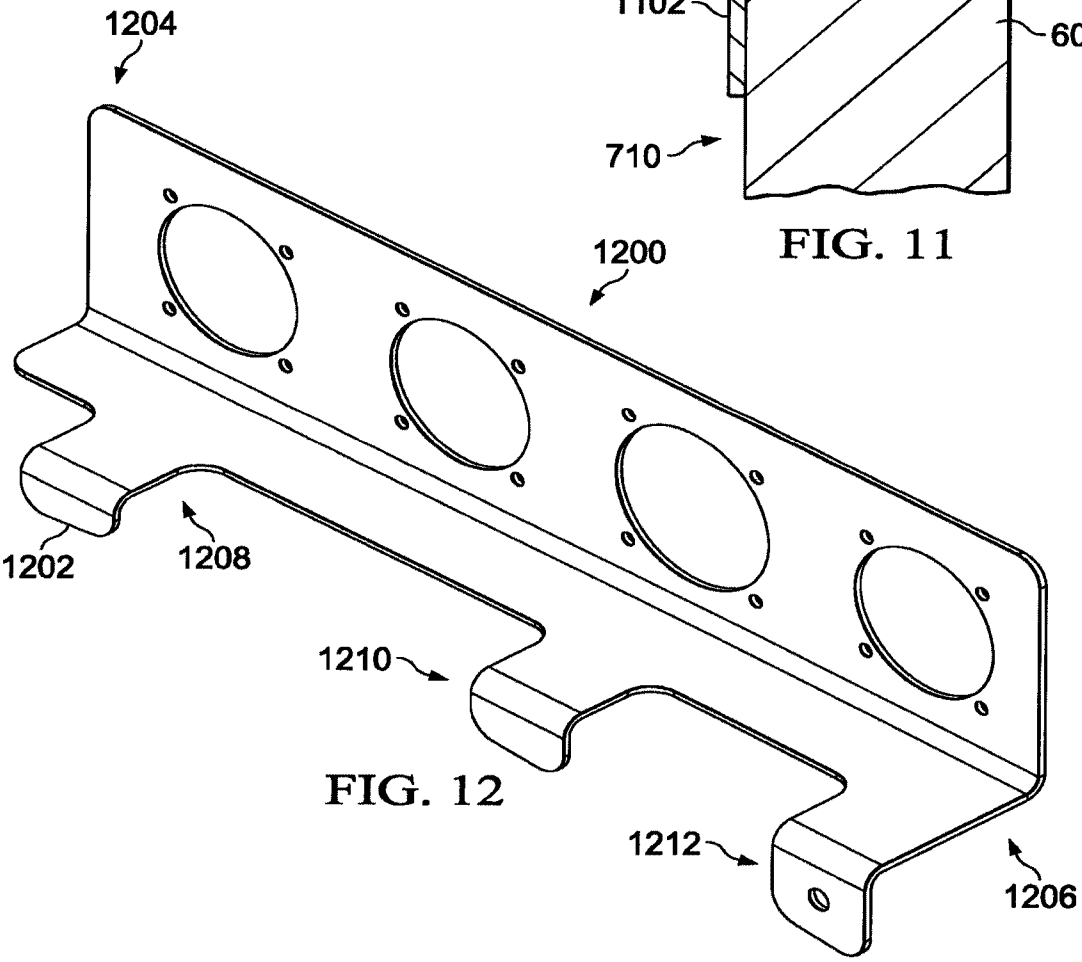

FIG. 12

10/19

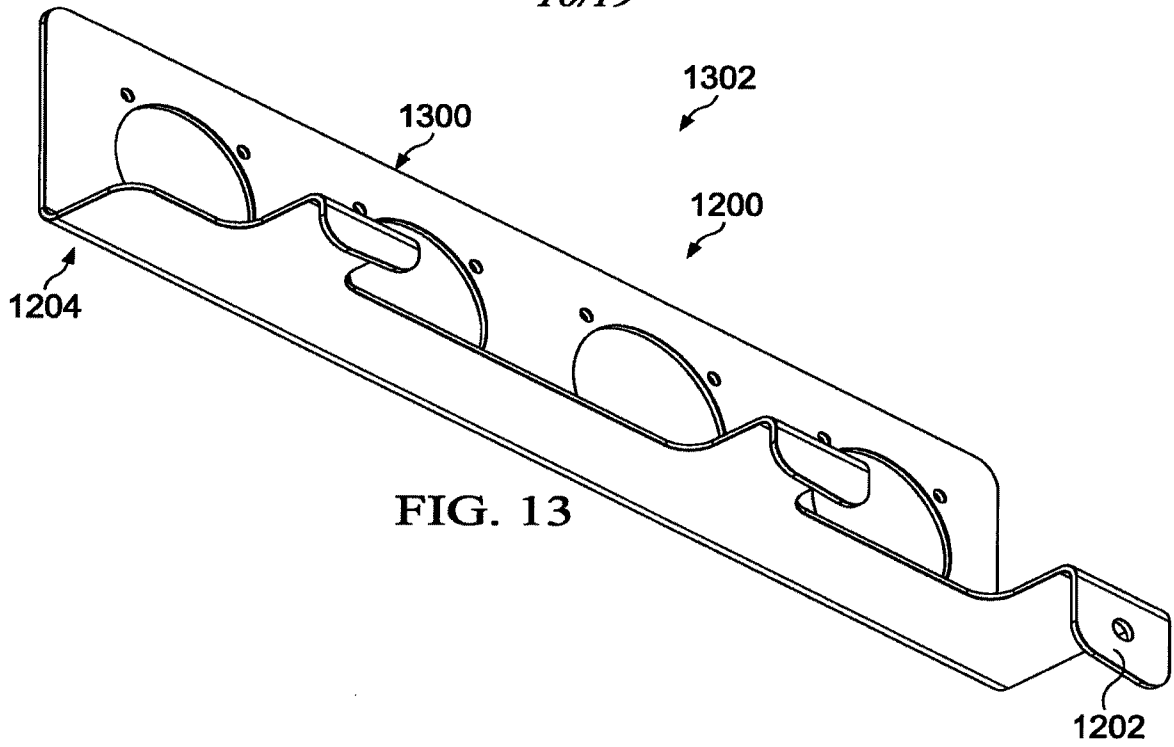

FIG. 13

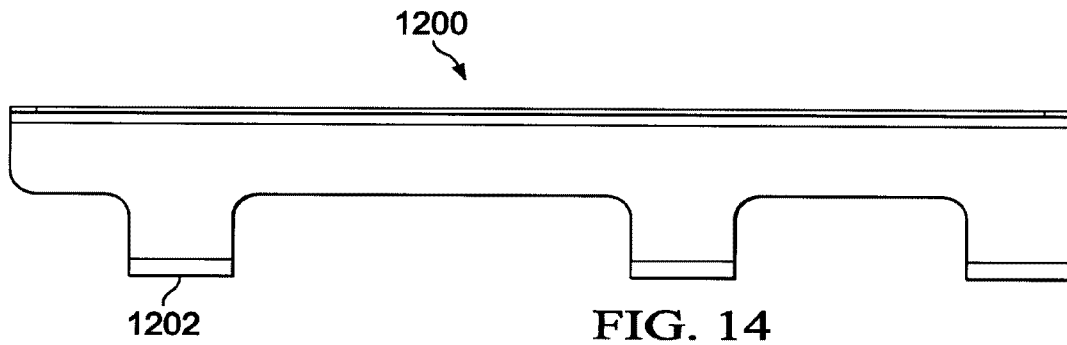

FIG. 14

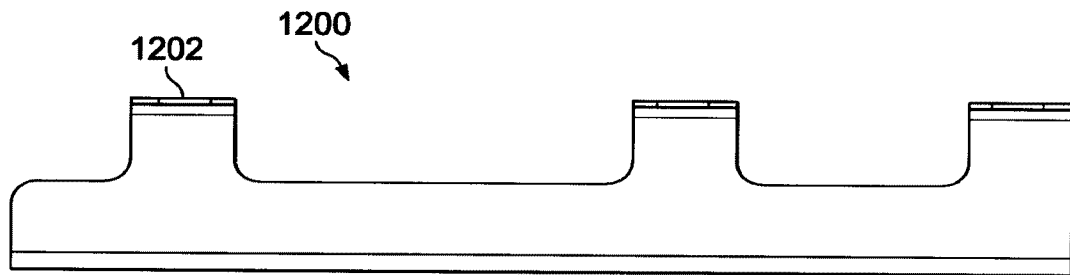

FIG. 15

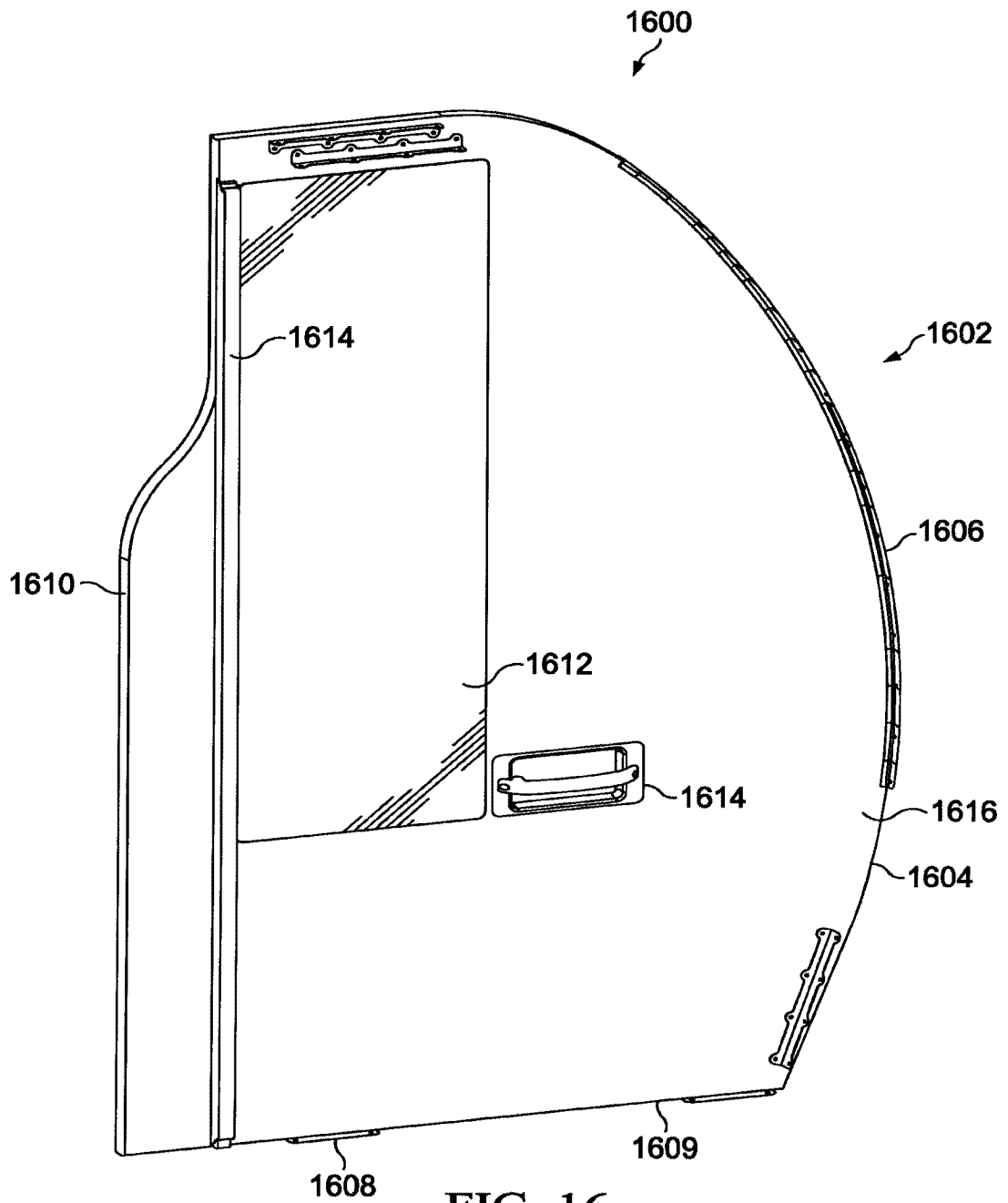

FIG. 16

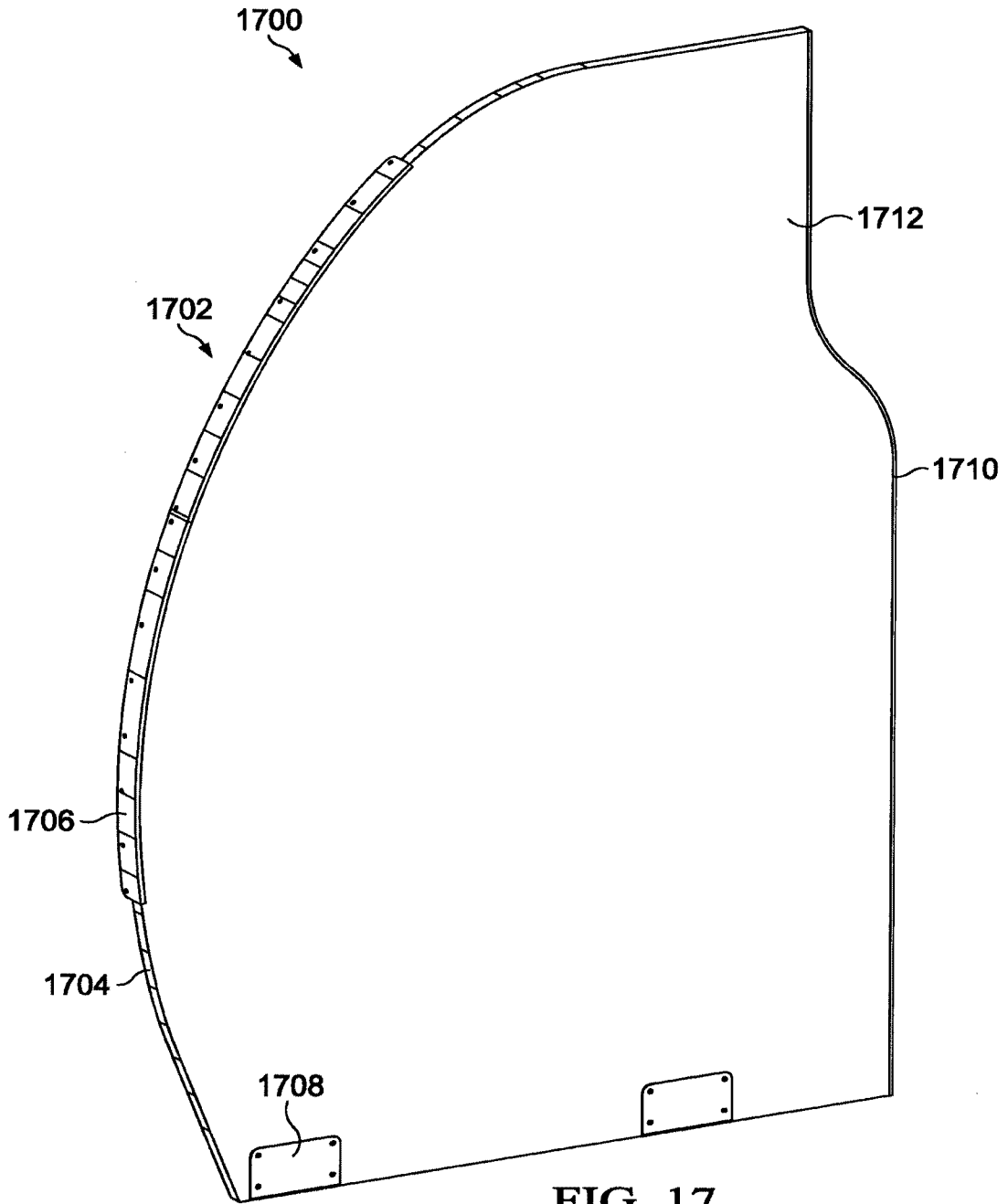

FIG. 17

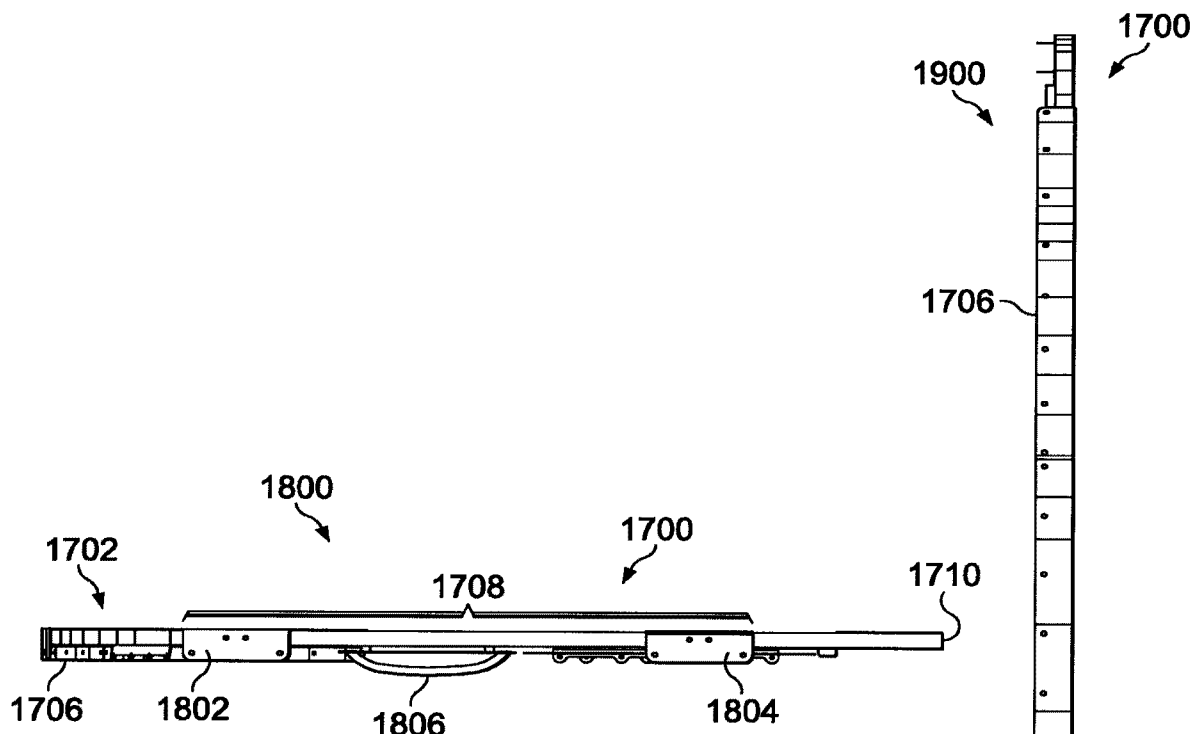

FIG. 18

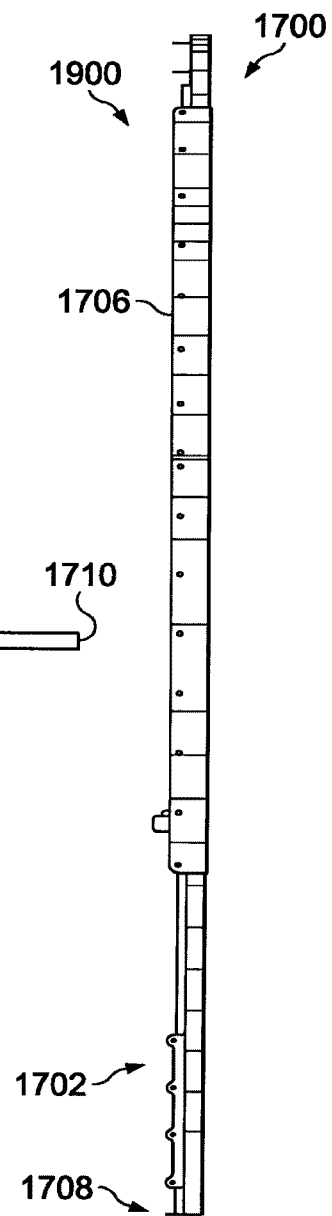
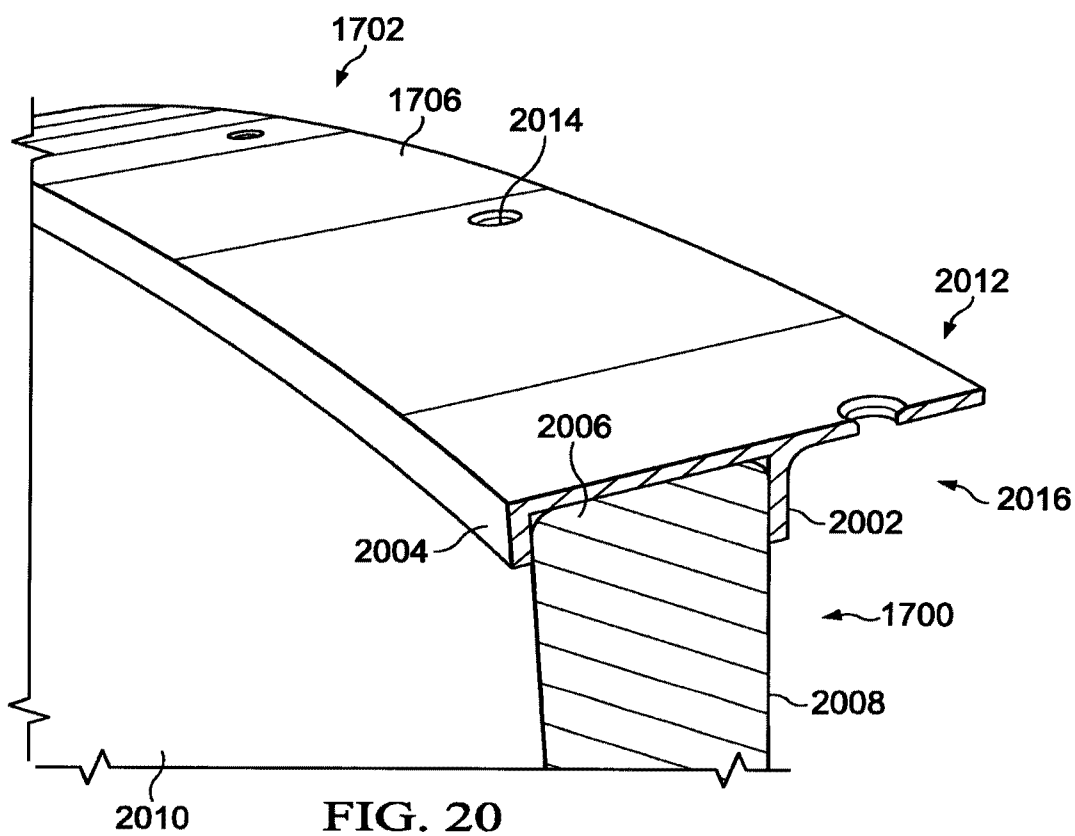

FIG. 19



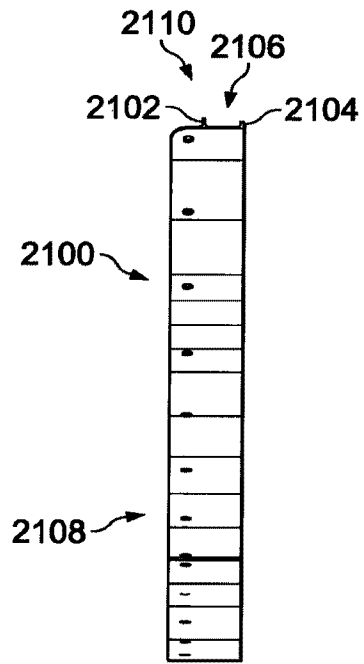

FIG. 21

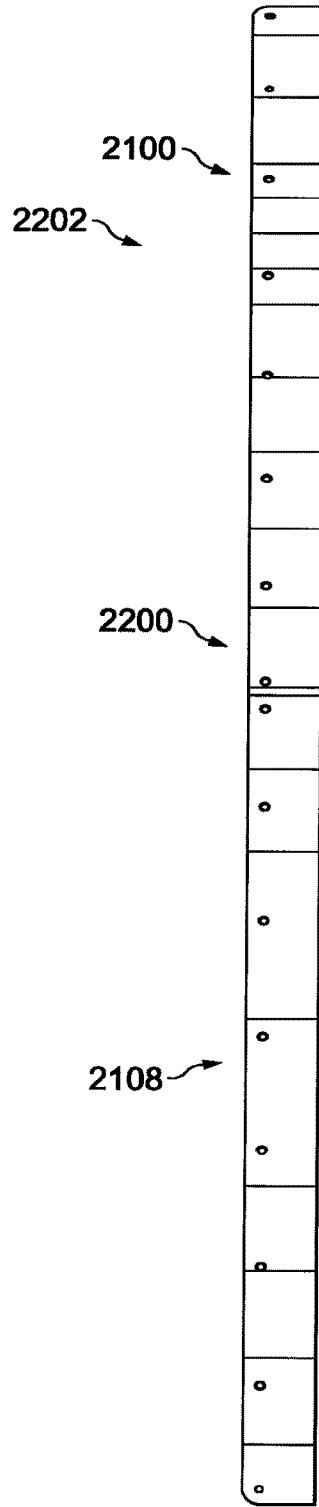

FIG. 22

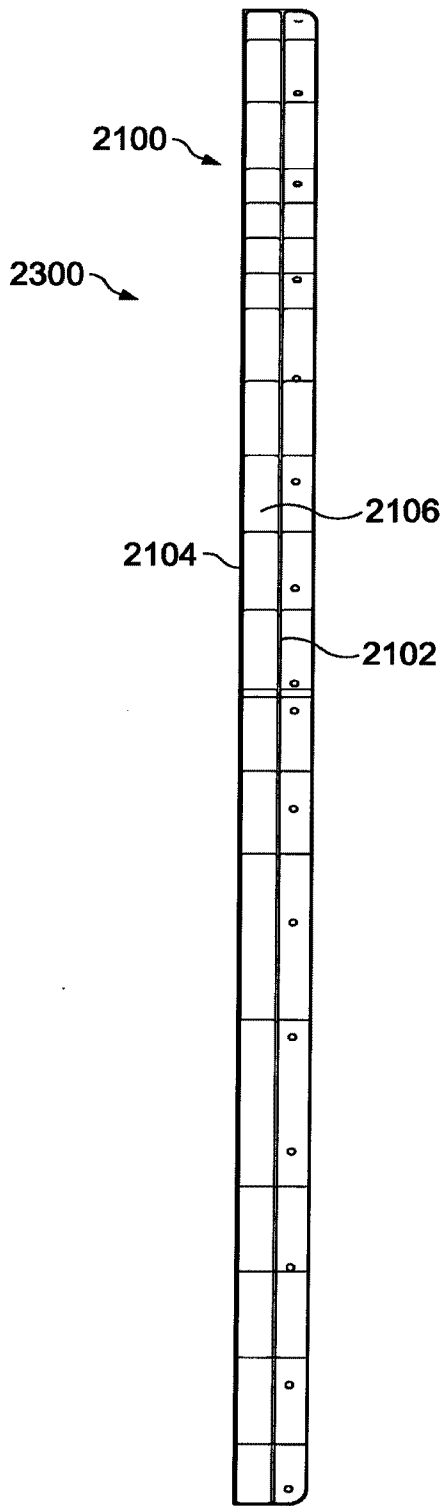

FIG. 23



FIG. 24

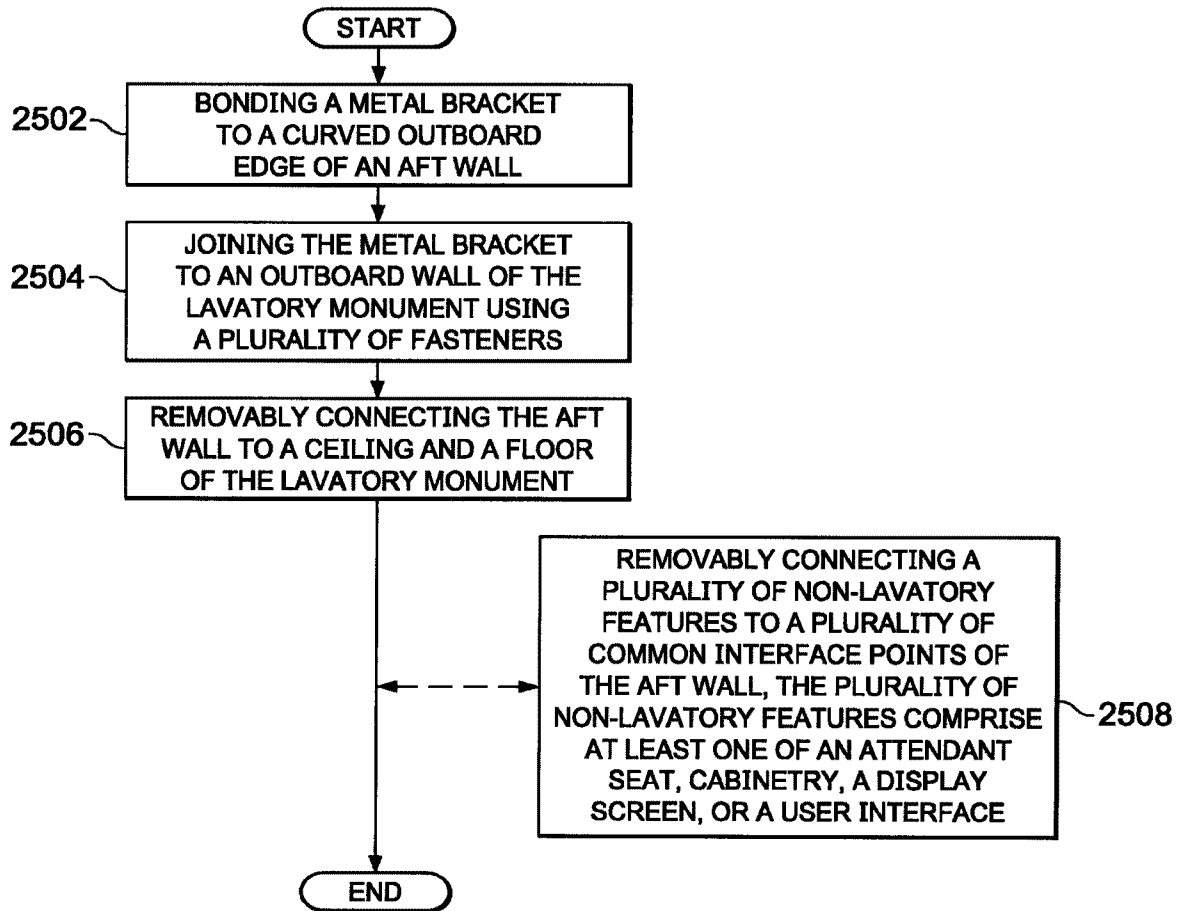

FIG. 25

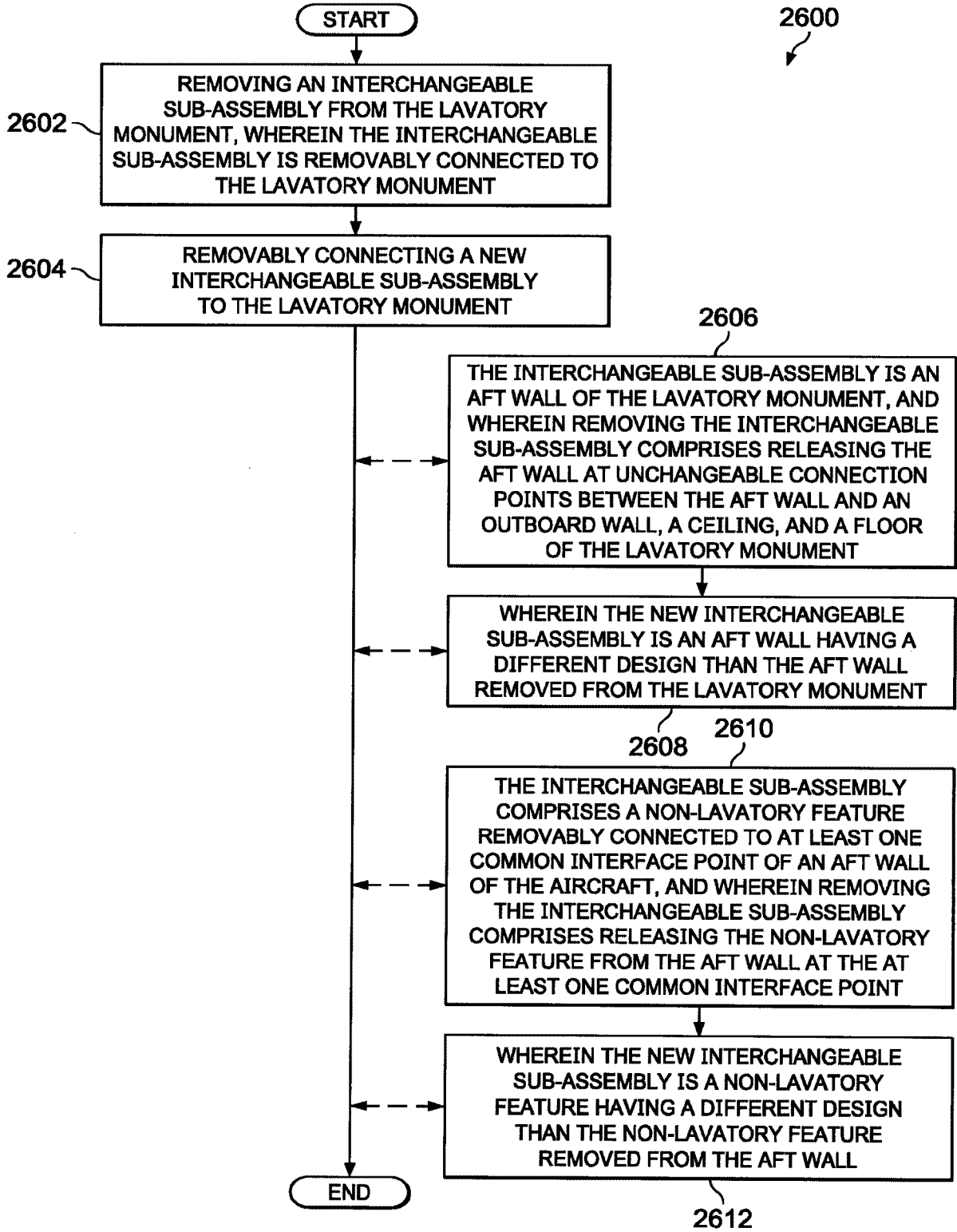

FIG. 26

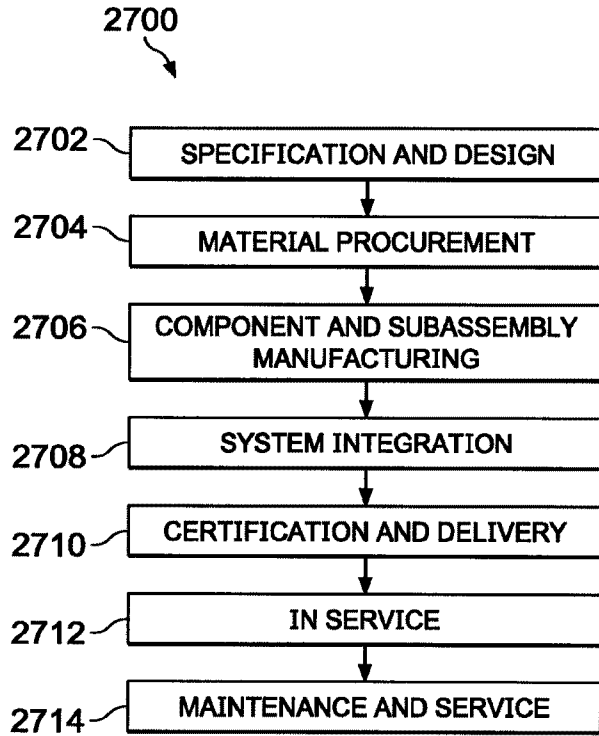

FIG. 27

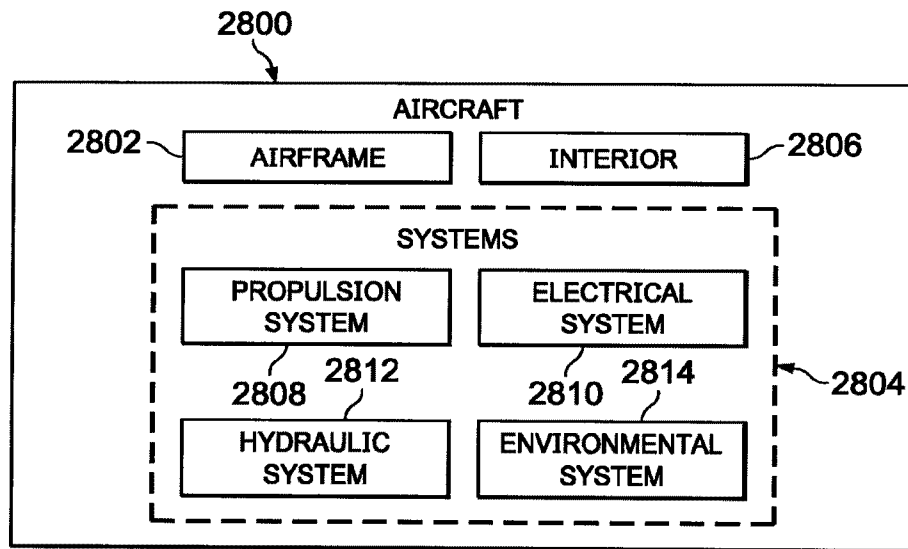

FIG. 28

