

No. 880,927.

PATENTED MAR. 3, 1908.

J. W. SMITH & S. A. CULBRETH.  
JOURNAL BOX.

APPLICATION FILED JUNE 26, 1907.

2 SHEETS—SHEET 1.

Fig. 1.

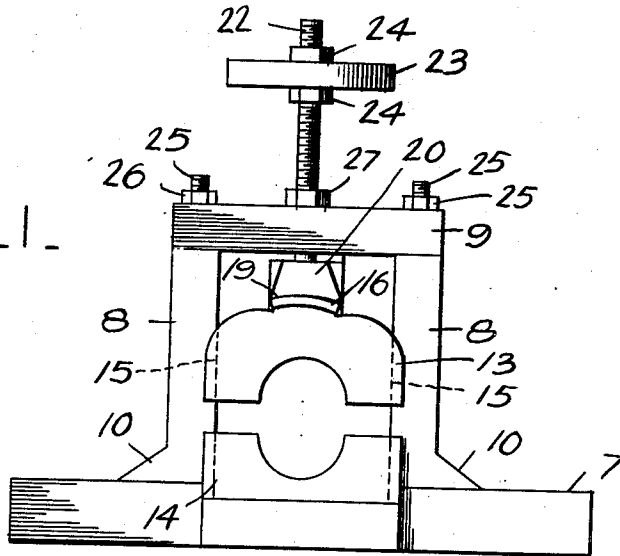

Fig. 2.

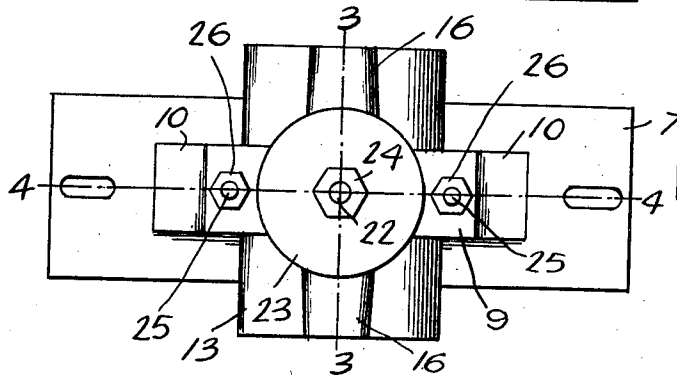
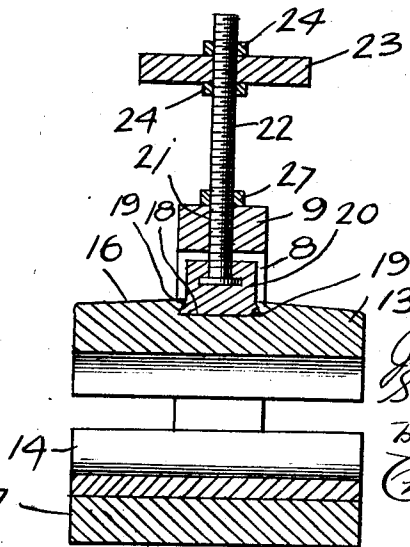

Fig. 3.



Witnesses  
*M. J. Rockwell*  
*A. C. McCarty*

Inventors  
*Joseph W. Smith*  
*Starling A. Culbreth*

By  
*Charles Chanute*  
 Attorney

No. 880,927.

PATENTED MAR. 3, 1908.

J. W. SMITH & S. A. CULBRETH.  
JOURNAL BOX.

APPLICATION FILED JUNE 26, 1907.

2 SHEETS—SHEET 2.

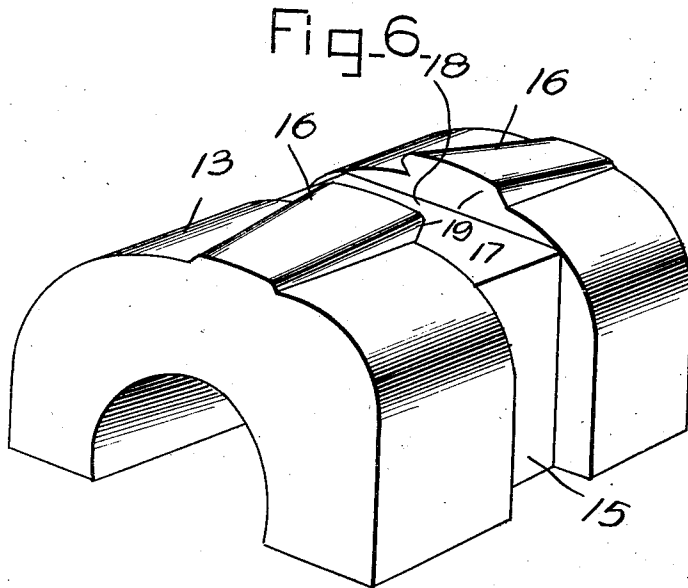
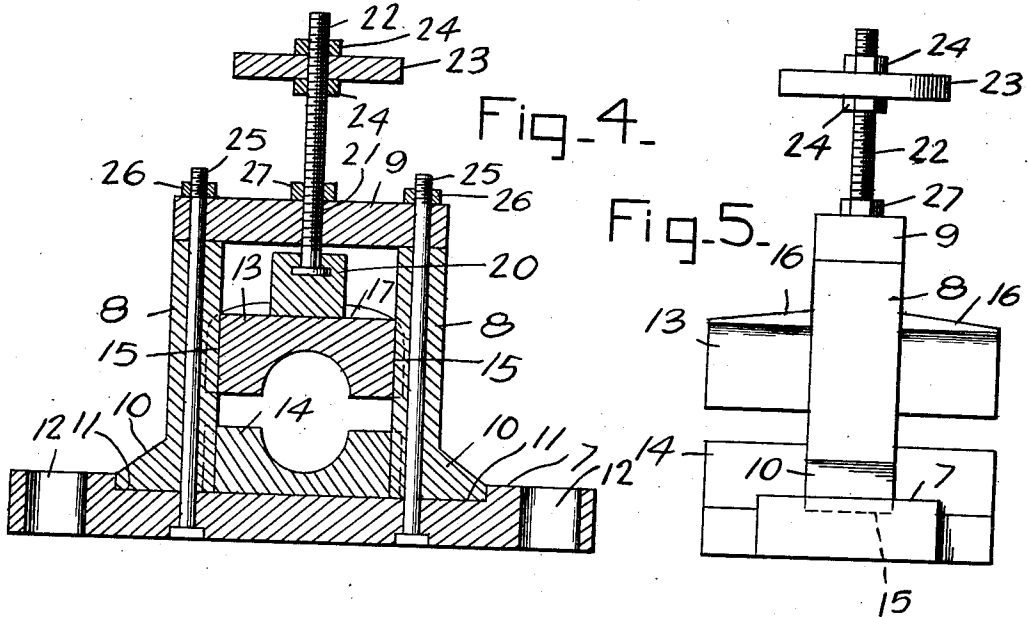

Witnesses  
*W. J. Rockwell*  
*A. C. Carter*

Inventors  
*Joseph W. Smith*  
*Starling A. Culbreth*

By *Thomas Chandler*

Attorney &

# UNITED STATES PATENT OFFICE.

JOSEPH W. SMITH AND STARLING A. CULBRETH, OF GORDON, ALABAMA.

## JOURNAL-BOX.

No. 880,927.

Specification of Letters Patent.

Patented March 3, 1908.

Application filed June 26, 1907. Serial No. 380,911.

*To all whom it may concern:*

Be it known that we, JOSEPH W. SMITH and STARLING A. CULBRETH, citizens of the United States, residing at Gordon, in the county of Houston, State of Alabama, have invented certain new and useful Improvements in Journal-Boxes; and we do hereby declare the following to be a full, clear, and exact description of the invention, such as will enable others skilled in the art to which it appertains to make and use the same.

The present invention has reference to improvements in journal boxes, and it aims to provide an exceedingly simple device of that nature, which is possessed of great durability and is so constructed as to be capable of being readily taken apart and set up again, whereby any part which has become worn or otherwise damaged may be readily replaced.

With the above and other ends in view, the invention consists in the construction, combination, and arrangement of parts, all as hereinafter more fully described, specifically claimed and illustrated in the accompanying drawings, in which like parts are designated by corresponding reference numerals in the several views.

Of the said drawings—Figure 1 is a front elevation of a journal box constructed in accordance with the present invention. Fig. 2 is a top plan view thereof. Figs. 3 and 4 are vertical sections taken respectively on the lines 3—3 and 4—4 of Fig. 2. Fig. 5 is a side elevation of the invention. Fig. 6 is a detail perspective view of the upper bearing member.

In its practical embodiment, the journal box comprises a supporting frame consisting of a base 7, a pair of oppositely-disposed standards 8, mounted thereon, and a cross-piece 9 connecting the upper ends of said standards. The lower ends of the standards are provided with feet 10, which fit in seats 11, formed upon the upper face of the base, which latter is further provided towards its opposite ends with a pair of elliptical openings 12, formed vertically therethrough, whereby a slight endwise adjustment of the journal box is rendered possible.

Between the standards 8 an upper half-bearing 13 and a lower half-bearing 14 are disposed, each of said bearings having oppositely-disposed alining recesses 15, formed in its sides, into which recesses the standards project, thus preventing any endwise move-

ment of said bearings. The upper bearing is further provided with a bowed longitudinal rib 16 formed upon its upper face and bisected by a transverse groove 17, which connects the recesses 15 above referred to, the intersection of the rib and groove forming a seat 18, whose front and rear walls are oppositely undercut, as shown, thus forming upon said rib a pair of oppositely-disposed shoulders 19, which project towards each other.

Disposed within the seat 18 is a block 20, whose front and rear walls are extended slightly adjacent their lower edges, and are oppositely beveled, as shown in Fig. 3, the flanges formed by said construction fitting in the under-cut walls of said seat.

The cross-piece 9, which connects the upper ends of the standards, as above stated, is provided with a threaded opening 21 formed vertically therethrough, through which opening extends an adjusting screw 22, whose lower end is swiveled in the block 20, while its upper end carries a hand-wheel 23, held in place thereon by means of jam-nuts 24, disposed adjacent its upper and lower faces, the provision of the hand-wheel enabling the adjusting screw to be rotated in one direction or the other, thus raising or lowering the upper bearing 13.

The standards are held in place upon the base and cross-piece connected thereto by means of a pair of bolts 25, which pass through openings formed vertically through said cross-piece, standards, and base, as shown, the projecting upper end of said bolts being provided with jam-nuts 26.

It will be apparent from the foregoing that the vertical movement of the upper bearing towards or from the lower bearing may be perfectly regulated by means of the adjusting screw, while the formation of the elliptical openings 12 in the base enables the entire supporting frame to be adjusted endwise.

It is further to be noted that the several parts which form the journal box are readily separable from each other, and that the entire device may, therefore, be dismantled and a worn or otherwise damaged part readily replaced by a new part.

In addition to the jam-nuts 24 above-referred to, the adjusting screw may be provided with an additional jam-nut 27 which is adapted to be screwed against the adjacent face of the cross-piece 9 to retain the upper bearing 13 in adjusted position.

Owing to the complete adjustment of the bearing sections it is unnecessary to make use of liners, and the trouble and delay incidental to the proper positioning of these devices are thus obviated.

What is claimed is—

1. In a journal box, the combination, with a supporting frame, of an upper and a lower bearing movable therein, said upper bearing having a longitudinal rib formed on its outer face provided intermediate its ends with a seat having oppositely-under-cut walls, a tapered block fitted in said seat, and a vertically-movable adjusting screw carried by said supporting frame, said screw having its lower end swiveled in said block and provided at its upper end with means for effecting its rotation in one direction or the other, to move the upper bearing towards or from the lower bearing.

2. In a journal box, the combination of a base provided upon its upper face with a pair of spaced seats; a pair of standards mounted upon said base and provided with feet fitting in said seats; a cross-piece connecting the upper ends of said standards, said cross-piece having a threaded opening formed vertically therethrough intermediate its ends; an upper bearing and a lower bearing mov-

able between said standards and provided with oppositely-disposed alining recesses formed in their side faces into which the standards extend, the upper bearing having a bowed longitudinal rib and a transverse seat formed on its outer face, said seat having its walls oppositely undercut; a block disposed within said last-mentioned seat and provided with oppositely beveled flanges formed on its front and rear faces and extending beneath the undercut walls of said seat; and an adjusting screw movable vertically through the threaded opening in said cross-piece, said screw having its lower end swiveled in said block and provided at its upper end with means for effecting its rotation in one direction or other, to move the upper bearing towards or from the lower bearing.

In testimony whereof, we affix our signatures in presence of witnesses.

JOSEPH W. SMITH.

STARLING A. CULBRETH.

Witnesses as to J. W. Smith:

J. W. BRETT,

G. V. McLENDON.

Witnesses as to Culbreth:

W. R. HORN,

W. H. VANLANDINGHAM.