

Geo. M. Weinman,

Steam Pump.

No. 109,980.

Patented Dec. 6. 1870.

Fig. 1.

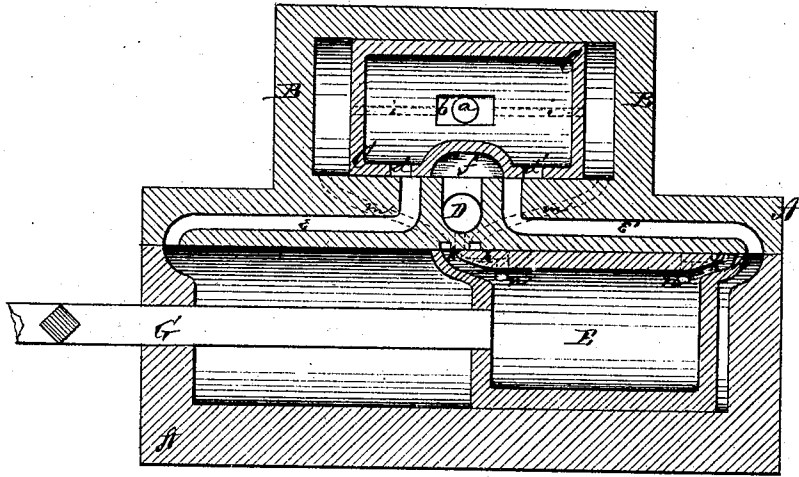
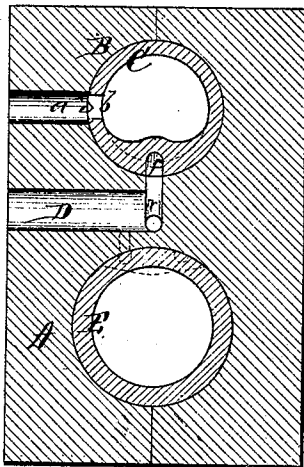

Fig. 2.



Witnesses:
C. L. Ewert,
J. O. Hutchinson

Inventor:
Geo. M. Weinman
per Alexander Mason
Attys.

UNITED STATES PATENT OFFICE.

GEORGE M. WEINMAN, OF COLUMBUS, OHIO.

IMPROVEMENT IN STEAM-PUMPS.

Specification forming part of Letters Patent No. 109,980, dated December 6, 1870.

To all whom it may concern:

Be it known that I, GEORGE M. WEINMAN, of Columbus, in the county of Franklin, and in the State of Ohio, have invented certain new and useful Improvements in Steam-Pump; and do hereby declare that the following is a full, clear, and exact description thereof, reference being had to the accompanying drawing, and to the letters of reference marked thereon, making a part of this specification.

The nature of my invention consists in the construction and arrangement of a steam-pump, as will be hereinafter fully set forth.

In order to enable others skilled in the art to which my invention appertains to make and use the same, I will now proceed to describe its construction and operation, referring to the annexed drawing, in which—

Figure 1 is a longitudinal vertical section of the steam-cylinder and steam-chest, and Fig. 2 is a transverse vertical section of the same.

A represents the steam-cylinder, with steam-chest B on the outside thereof. The steam enters the steam-chest through the port *a*, and passes at once through the elongated port *b* in the side of the hollow valve C into the same. From the valve C the steam passes, through either of the ports *d d'*, into one of the inlet-ports *e e'* in the cylinder A, and into the same at either end.

Between the two ports *d d'* in the valve C is a passage, *f*, so that when the valve is, for instance, in the position that the steam enters the cylinder at one end through the ports *d e*, the steam at the other end of the cylinder will pass through the port *e'* into the passage *f*, and out through the exhaust-port D. When the valve is moved to the other end of the steam-chest the position of the ports is reversed.

In the valve C, from the inlet-port *b*, there is a channel, *i*, leading to each end of the valve, through which channels there is a continual passage of steam, so as to have a pressure of steam on each end of the valve.

When the piston E moves to either end of the cylinder the steam at one end of the valve will be exhausted by means that will be presently described, and cause an excess of pres-

sure of steam at the other end, and consequently throw the valve back.

The piston-head E is hollow, and provided at each end with a lug, *h*, the cylinder A being provided with a corresponding recess at each end. Through each of these lugs is a passage, *k*, which, when the piston-head comes to one end of the cylinder, gets directly opposite the end of a passage, *m*, leading from the opposite end of the steam-chest into the center of the cylinder, and thus the steam at this end of the valve C is exhausted into the hollow piston, from which it passes, through the port *n*, into the main exhaust D. By this means, as soon as the piston-head completes its stroke, the steam at one end of the valve is exhausted, giving the steam at the other end sufficient overbalancing power to throw the valve back, when, of course, the piston-head is at once moved to the other end of the cylinder, and the same operation performed at that end.

The piston-head being hollow makes it lighter, and by having a lug, *h*, at each end, it keeps the port-holes covered. The piston-head is short, and when there is a pressure of steam on the same it will press on the lugs, and makes a tight joint over the three ports. The piston G is made square, to keep the piston-head from turning, so as to keep the lugs in their proper places. It does away with a set-screw.

Having thus fully described my invention, what I claim as new, and desire to secure by Letters Patent, is—

1. The hollow piston-head E, provided with lugs *h h* and ports *k k* and *n n*, substantially as and for the purposes herein set forth.

2. In combination with the hollow piston-head E, constructed as described, the square piston-rod G, substantially as and for the purposes herein set forth.

3. The combination of the steam-cylinder A and steam-chest B, when provided with steam-channels *e e'*, for operating the piston, and channels *m m*, for exhausting the valve, substantially as herein set forth.

4. The hollow valve C, provided with steam-inlet *b*, channels *i i*, ports *d d'*, and passage *f*, and operating within the steam-chest B,

substantially as and for the purposes herein set forth.

5. The combination of the cylinder A, steam-chest B, hollow valve C, with steam-inlet *b*, channels *i*, ports *d d'*, and passage *f*, the channels *e e'* and *m n*, hollow piston-head E, with lugs *h h*, ports *k k* and *n n*, and the main exhaust D, all constructed and arranged to operate substantially as and for the purposes herein set forth.

In testimony that I claim the foregoing I have hereunto set my hand this 1st day of September, 1870.

GEORGE M. WEINMAN.

Witnesses:

W. C. STEWART,

G. G. COLLINS.