

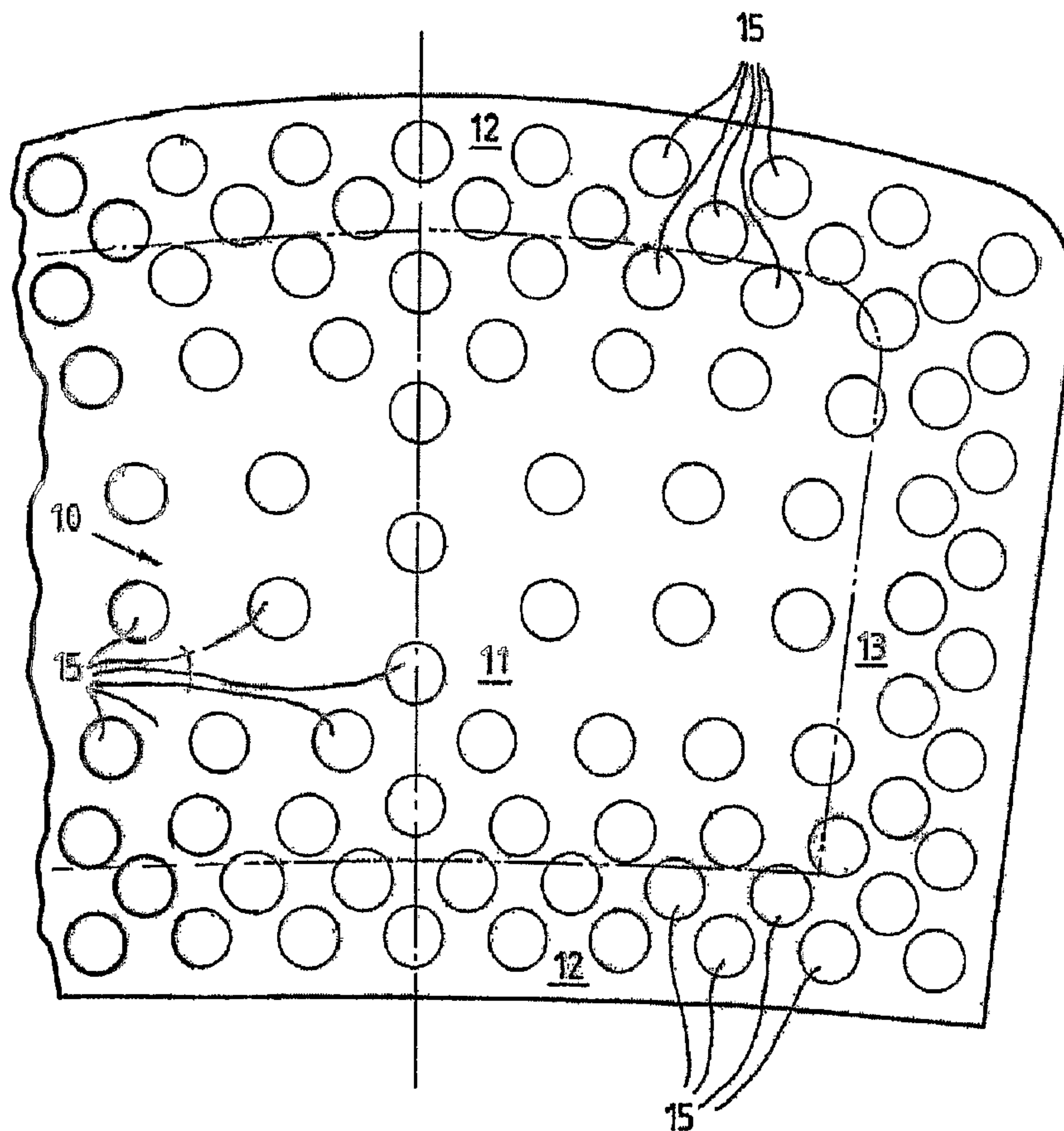

(86) Date de dépôt PCT/PCT Filing Date: 2004/03/22
 (87) Date publication PCT/PCT Publication Date: 2004/10/07
 (45) Date de délivrance/Issue Date: 2012/09/11
 (85) Entrée phase nationale/National Entry: 2005/09/23
 (86) N° demande PCT/PCT Application No.: EP 2004/002979
 (87) N° publication PCT/PCT Publication No.: 2004/085325
 (30) Priorité/Priority: 2003/03/28 (DE103 14 408.0)

(51) Cl.Int./Int.Cl. *C03B 23/035* (2006.01),
C03B 35/24 (2006.01)
 (72) Inventeurs/Inventors:
FUNK, DIETER, DE;
PILZ, JOACHIM, DE;
MICHELS, PETER, DE
 (73) Propriétaire/Owner:
PILKINGTON AUTOMOTIVE DEUTSCHLAND GMBH,
DE
 (74) Agent: FINLAYSON & SINGLEHURST

(54) Titre : DISPOSITIF DE PRODUCTION D'UN COUSSIN DE GAZ
 (54) Title: DEVICE FOR PRODUCING A GAS CUSHION



(57) Abrégé/Abstract:

The gas cushion serves to support a preheated glass sheet and is produced by a chamber, which is connected to a source (21) of compressed gas. The upper wall (10) of the chamber is adapted to the shape of the glass sheet and has a plurality of apertures for



(57) **Abrégé(suite)/Abstract(continued):**

the passage of gas in the form of nozzles (14), which comprise an entry bore (22) and, following thereupon, a progressively widening exit hole (16) with a nozzle exit area (15). The upper wall (10) of the chamber has a greater degree of perforation (sum of the nozzle exit areas (15) in relation to the total area of the respective zone) in its edge zone (12, 13) than in its central zone (11). The nozzles ensure that no jet marks can arise. The gas of the gas cushion can also flow out undisturbed at the side, so that no cooling edges are present and the occurrence of cooling shadows is accordingly avoided.

(12) INTERNATIONAL APPLICATION PUBLISHED UNDER THE PATENT COOPERATION TREATY (PCT)

(19) World Intellectual Property
Organization
International Bureau



(43) International Publication Date
7 October 2004 (07.10.2004)

PCT

(10) International Publication Number
WO 2004/085325 A1

(51) International Patent Classification⁷: **C03B 23/035,**
35/24

(21) International Application Number:
PCT/EP2004/002979

(22) International Filing Date: 22 March 2004 (22.03.2004)

(25) Filing Language: English

(26) Publication Language: English

(30) Priority Data:
103 14 408.0 28 March 2003 (28.03.2003) DE

(71) Applicant (for all designated States except US): **PILK-
INGTON AUTOMOTIVE DEUTSCHLAND GMBH**
[DE/DE]; Otto-Seeling-Str. 7, 58455 Witten (DE).

(72) Inventors; and

(75) Inventors/Applicants (for US only): **FUNK, Dieter**

[DE/DE]; Schützenstrasse 16, 58452 Witten (DE). **PILZ,
Joachim** [DE/DE]; Haardstrasse 63, 45739 Oer-Erken-
schwick (DE). **MICHELS, Peter** [DE/DE]; Am Kindler
1., 45549 Sprockhövel (DE).

(74) Agents: **HALLIWELL, Anthony, Charles** et al.; Group
Intellectual Property Department, Pilkington European
Technical Centre, Pilkington plc, Hall Lane, Lathom,
Ormskirk, Lancashire L40 5UF (GB).

(81) Designated States (unless otherwise indicated, for every
kind of national protection available): AE, AG, AL, AM,
AT, AU, AZ, BA, BB, BG, BR, BW, BY, BZ, CA, CH, CN,
CO, CR, CU, CZ, DE, DK, DM, DZ, EC, EE, EG, ES, FI,
GB, GD, GE, GH, GM, HR, HU, ID, IL, IN, IS, JP, KE,
KG, KP, KR, KZ, LC, LK, LR, LS, LT, LU, LV, MA, MD,
MG, MK, MN, MW, MX, MZ, NA, NI, NO, NZ, OM, PG,
PH, PL, PT, RO, RU, SC, SD, SE, SG, SK, SL, SY, TJ, TM,
TN, TR, TT, TZ, UA, UG, US, UZ, VC, VN, YU, ZA, ZM,
ZW.

[Continued on next page]

(54) Title: DEVICE FOR PRODUCING A GAS CUSHION

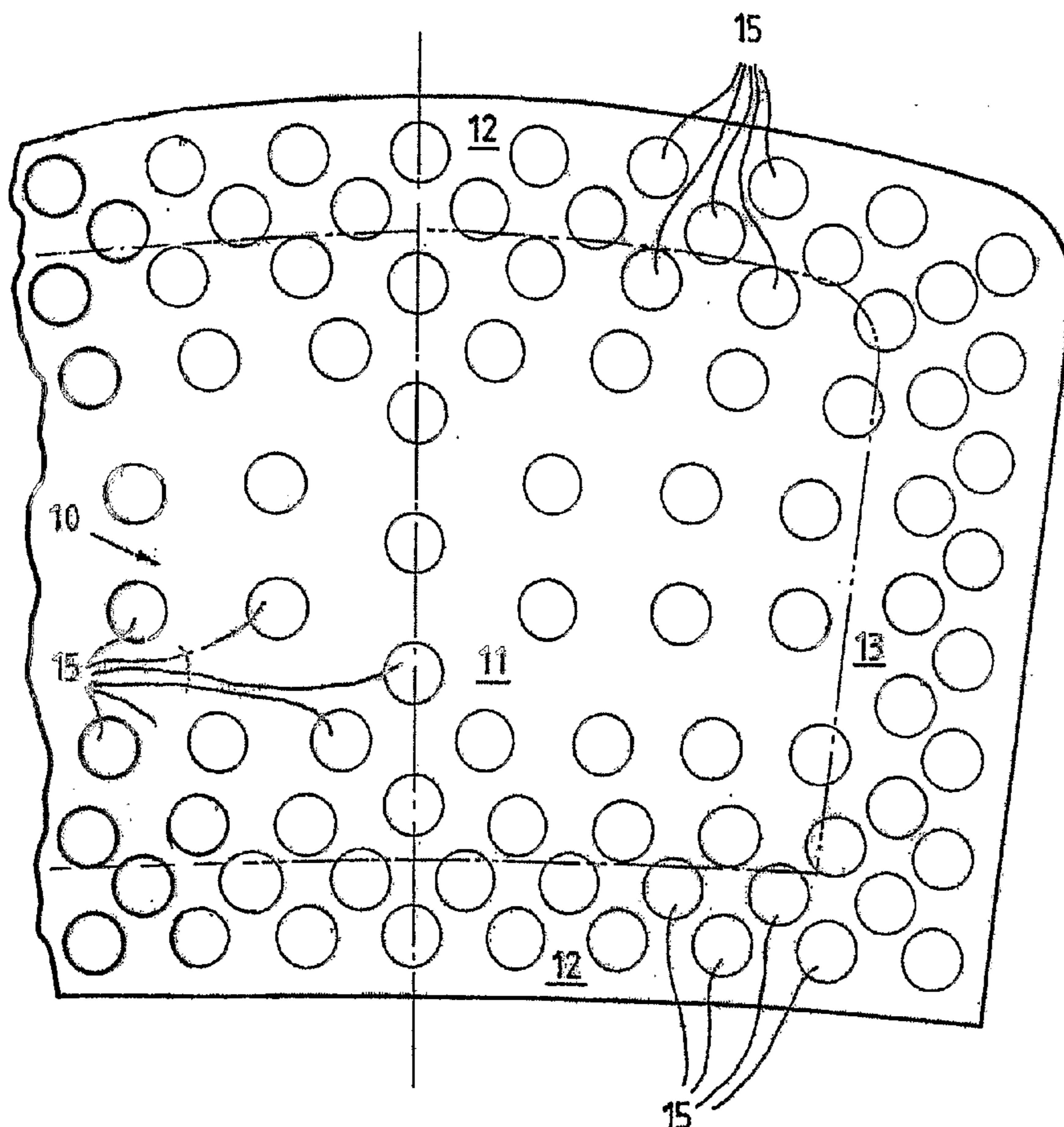

(57) Abstract: The gas cushion serves to support a preheated glass sheet and is produced by a chamber, which is connected to a source (21) of compressed gas. The upper wall (10) of the chamber is adapted to the shape of the glass sheet and has a plurality of apertures for the passage of gas in the form of nozzles (14), which comprise an entry bore (22) and, following thereupon, a progressively widening exit hole (16) with a nozzle exit area (15). The upper wall (10) of the chamber has a greater degree of perforation (sum of the nozzle exit areas (15) in relation to the total area of the respective zone) in its edge zone (12, 13) than in its central zone (11). The nozzles ensure that no jet marks can arise. The gas of the gas cushion can also flow out undisturbed at the side, so that no cooling edges are present and the occurrence of cooling shadows is accordingly avoided.

WO 2004/085325 A1

WO 2004/085325 A1

(84) Designated States (*unless otherwise indicated, for every kind of regional protection available*): ARIPO (BW, GH, GM, KE, LS, MW, MZ, SD, SL, SZ, TZ, UG, ZM, ZW), Eurasian (AM, AZ, BY, KG, KZ, MD, RU, TJ, TM), European (AT, BE, BG, CH, CY, CZ, DE, DK, EE, ES, FI, FR, GB, GR, HU, IE, IT, LU, MC, NL, PL, PT, RO, SE, SI, SK, TR), OAPI (BF, BJ, CF, CG, CI, CM, GA, GN, GQ, GW, ML, MR, NE, SN, TD, TG).

For two-letter codes and other abbreviations, refer to the "Guidance Notes on Codes and Abbreviations" appearing at the beginning of each regular issue of the PCT Gazette.

Published:

— *with international search report*

Device for Producing a Gas Cushion

5 The invention relates to a device for producing a gas cushion for supporting a preheated glass sheet, comprising a chamber connected to a source of compressed gas, the upper wall of which chamber is adapted in its external dimensions to the outline of the glass sheet and has a plurality of apertures for the passage of gas.

10 The device can be used wherever it is a matter of supporting a preheated glass sheet, for example a glass sheet that is to be toughened. The main area of use, however, is the production of bent laminated glass panels, in particular for the construction of motor vehicles. A laminated window for a vehicle normally comprises two plies of glass, wherein in use one ply forms the inner surface of the window (i.e. it faces towards the vehicle interior), and the other ply forms the outer or exterior surface of the window.

15 During manufacture of the window, a pair of glass sheets is heated up to the bending temperature in a preheating furnace and then conveyed to a press-bending station. Each member of the pair of sheets may be heated individually, e.g. inner and outer plies are conveyed separately through the furnace, possibly with the inner and outer plies in alternating sequence. Alternatively, the pair may be heated as a nested pair, i.e. with one ply (normally the inner ply) superposed on the other.

25 The device for producing the gas cushion forms a component of the press-bending station. The respective glass sheet, or nested pair of sheets, passes from the rollers of the preheating furnace onto the gas cushion and is brought to a halt here and also centred relative to the bending mould. If rollers were also to be used here, the unavoidable dwell time would lead to the formation of markings which would considerably impair the optical properties of the glass sheet.

30 The chamber comprises walls defining an internal space containing gas, and has in particular an upper wall, i.e. the wall which has an upward-facing external surface, which may be thought of as the "roof" of the chamber. The external dimensions of the upper wall of the chamber are adapted to the outline (the external dimensions) of the glass sheet, but as a rule are somewhat smaller than the external dimensions of the glass sheet to be supported, so that

the glass sheet in the final position projects a few centimetres beyond the edge of the upper wall of the chamber on several, in particular on all sides, so that it can be taken up by an annular mould surrounding the chamber.

5 A device of the type mentioned at the outset is known from EP 0 578 542 B1. The apertures for the passage of gas are arranged there in lines in the upper wall of the chamber, whereby there are provided between neighbouring pairs of lines slot-shaped gas discharge channels, which lead from the upper side of the chamber through the chamber to its lower side and enable an undisturbed discharge of the gas of the gas cushion.

10

It has however been found that the optical properties of the glass sheets hereby achievable are capable of improvement, and the problem underlying the invention is therefore to achieve such an improvement.

15 To solve this problem, the device mentioned at the outset is characterised according to the invention in that the apertures for the passage of gas are designed as nozzles, which have an entry bore as well as a progressively widening exit hole with a nozzle exit area, and that the upper wall of the chamber has a larger degree of perforation (sum of all the nozzle exit areas in relation to the total area of the respective zone) in its edge zones than in its central zone.

20

The invention is based on the knowledge that the known device mentioned at the outset produces certain optical impairments of the glass sheets, which can be traced back to two phenomena which can even be locally superimposed.

25 On the one hand, the edges of the slot-shaped discharge channels form so-called cooling edges, which produce cooling shadows on the glass surface. On the other hand, so-called jet marks occur in the flow impact zone of the gas jets emerging from the apertures for the passage of gas. In both cases, it leads to a non-uniform cooling rate and thus to a non-uniform heat distribution, which results in a non-uniform stress distribution.

30

In order to avoid jet marks, it is known from EP 0 523 016 B1 to allow the gas jets to emerge from nozzles which have an entry bore as well as a progressively widening exit hole. These nozzles are formed by nozzle bodies which are screwed into the upper wall of the chamber and project upwards from the latter. The gas of the gas cushion is diverted downwards between

the nozzle bodies and then guided away at the side. At their upper ends, the nozzle bodies thus form discharge edges, which also act as cooling edges and produce corresponding cooling shadows.

5 In contrast, neither jet marks nor cooling shadows occur according to the invention. The gas flow is slowed down during the passage through the nozzles with a corresponding pressure build-up, so that a large-area uniform gas exit can be guaranteed. Since the nozzles are integrated into the upper wall of the chamber, there is no gas deflection directed downwards at the nozzle exit, so that no discharge edges with a corresponding cooling effect are formed
10 either. Furthermore, no entry bores from discharge channels are provided in the upper wall of the chamber. In this regard too, the creation of cooling shadows is thus eliminated.

The discharge of the gas of the gas cushion takes place horizontally between the glass sheet and the upper wall of the chamber. Surprisingly, it has been found that it is sufficient to
15 reduce the degree of perforation in the central zone of the upper wall of the chamber in order to guarantee an undisturbed discharge of the gas of the gas cushion. Whilst being highly effective, this measure is extremely simple. The glass sheet retains its flat, horizontal alignment, without arching up in the central zone or forming sagging zones at the edges. An adverse effect on centring on the bending tools is thus ruled out.

20

Overall, the device according to the invention enables the production of bent glass sheets of the highest optical quality. This is of great importance, especially for the construction of motor vehicles. This is because here it is not only the demands on the shape tolerances of the glass sheets and their optical quality that are becoming increasingly strict, but there is also an
25 increasing tendency to display information on the windscreen (head-up displays). The prerequisite for this is windscreens of the highest optical quality.

To advantage, the central zone of the upper wall of the chamber, which within the scope of the invention is decisive for determining the conditions for the degree of perforation, corresponds
30 in the magnitude of its area roughly to the sum of the edge zones.

Particularly favourable results can be achieved when the ratio of the degree of perforation in the central zone of the upper wall of the chamber to the degree of perforation in the edge zones amounts to approx. 0.5 to 0.9, preferably approx. 0.7 – 0.8. It is understood here that the

stated values are not to be understood as sharply defined limiting values, but that, in the individual case in particular, fairly large differences in the degree of perforation between the two zones may also be advisable. Tests have shown that the degree of perforation in the central zone of the upper wall of the chamber should as a rule amount to a maximum of approx. 0.3, preferably less than 0.25, in order reliably to avoid an undesirable upward arching of the glass sheet.

Furthermore, it is advantageous for the upper wall of the chamber to have a greater degree of perforation in the edge zones of its longer sides than in the edge zones of its shorter sides. Optimum adaptation to the geometrical conditions of the glass sheet thus arises. The smaller supporting requirement in the edge zones of the shorter sides is used to promote the discharge of the gas of the gas cushion.

The upper wall of the chamber will as a rule be designed to have rough mirror symmetry in order to simplify the design and production of the chamber. The degree of perforation to the left and right of a central axis of mirror symmetry will then be roughly in agreement. A further optimisation of the gas cushion function can however take place according to a preferred variant of the invention in that the degree of perforation diminishes from the glass-sheet feed side, which will normally be one of the short sides of the chamber, to the opposite side. Account can thus be taken of the fact that the glass sheet, when it is pushed into position over the upper wall of the chamber, pushes a gas cushion ahead of it, so that at the end of the transfer operation less and less gas has to be supplied from the chamber. As an alternative to this, a gas pressure diminishing from the feed side to the opposite side can also be provided for by a suitable adaptation of the nozzle cross-sections in the case of a degree of perforation which is symmetrical about the central mirror axis.

Each nozzle comprises an entry bore in communication with an exit hole, which is flared, i.e. it widens in the direction of flow. A uniform gas outflow with a low speed of flow is brought about by the widening exit hole of the nozzles. This effect can however be enhanced further if the entry bore of the nozzles widens at least once abruptly in the direction of flow.

It is particularly advantageous for the entry bore of the nozzles to have a first section with a diameter of approx. 2 to 4 mm, preferably of approx. 3 mm, as well as a second section with a diameter of approx. 20 mm, whereby the exit hole follows on from the latter. The entry bore

can have a third section with a diameter of approx. 10 mm between the first and the second section. The first, second and third sections are preferably formed cylindrically and have coincident cylinder axes. The exit hole of the nozzles preferably widens conically up to the nozzle exit area with a diameter of approx. 60 mm. It goes without saying that the stated numerical values merely represent rough guidance values from which deviations are possible in both directions, without leaving the scope of the invention. The important thing is that the nozzles are designed in such a way that the gas strikes the glass surface without local pressure peaks, thereby avoiding jet marks.

10 In an important development of the invention, the upper wall of the chamber is covered by a thin porous cloth made of heat-resistant material. This cloth contributes in large measure to rendering the gas flow uniform over the area of the upper wall of the chamber. The cloth also forms an area of uniform temperature, which helps to render the cooling rate, the heat distribution and the stress distribution uniform. From this viewpoint, it is particularly
15 advantageous for the cloth to be made of heat-conductive material, preferably of corrosion-resistant steel (stainless steel).

For the chamber, consideration can in principle be given to any sufficiently temperature-resistant material. Preferably, however, the chamber is made of ceramic material. Heating
20 elements are preferably installed in the chamber, whereby consideration is given in particular to electric heating.

It was stated above that the first section of the entry bores should preferably have a diameter of approx. 3 mm. This value relates to ceramic chambers, since smaller diameters cannot be
25 drilled in ceramics. When other materials are used for the chamber, it is possible to use smaller diameters if need be, as a result of which the supporting behaviour and the temperature distribution of the gas cushion can be designed even more favourably. Overall, however, the advantages of the ceramic design predominate.

30

Here, the chamber is preferably designed as a one-piece moulding.

The invention will be explained in greater detail below with the aid of preferred examples of embodiment in connection with the appended drawings. The drawings show the following:

- Figure 1: in diagrammatic representation, a vertical section through a plant in which the device according to the invention is integrated;
- 5 Figure 2: a plan view of the plant according to Figure 1;
- Figure 3: a partial plan view of a first form of embodiment of the device according to the invention;
- 10 Figure 4: a partial plan view of a second form of embodiment of the device according to the invention;
- Figure 5: a section through a first nozzle design;
- 15 Figure 6: a section through a second nozzle design.

The plant according to Figures 1 and 2 has a preheating furnace 1, which serves to pre-heat glass sheets 2 of a glass-sheet pair. Glass sheets 2 advance through the furnace on rollers 3, whose spacing is reduced in the area of the furnace exit, since the heated glass sheets are deformable and therefore require more intensive support. Preheating furnace 1 is followed by
20 a bending station 4, which is provided with a glass-bending mould 5 in the form of a ring, which conforms in outline and elevation to the desired shape of the glass sheet after bending, and a full surface contact vacuum mould 6.

25 The present invention relates especially to gas chamber 7 for producing the gas cushion, represented diagrammatically in Figure 1. Chamber 7 has an upper wall 10, such as is shown in partial plan views in Figures 3 and 4, and is surrounded by the ring mould 5. The upper wall may also, in broad terms, conform in outline and elevation to the desired shape of glass sheet to be manufactured, allowing for the fact that, as previously noted, the chamber 7 is
30 slightly smaller than the ring mould 5 (and hence also the glass sheet) so that the chamber may pass through the ring mould. Alternatively, the upper wall of the chamber may possess a shape which is a more general approximation of the shape of the bent glass sheet, and be used for the production of bent glass sheets for several different vehicles. If only a moderate degree of bending is required, the upper wall of the chamber may be flat.

Referring to Figure 1, the chamber 7 serves to build up a gas cushion, being supplied with compressed gas (e.g. air) by a source of compressed gas which is diagrammatically represented and designated by reference numeral 21. Glass sheets 2 transfer onto this gas cushion as soon as they leave preheating furnace 1. Chamber 7 then descends and places
5 respective glass sheet 2 onto ring mould 5. At the same time, the vacuum mould is conveyed downwards in order to engage respective glass sheet 2 by suction and to bring it into the desired shape. A transport device 8, e.g. a roller conveyor (Figure 2), serves to convey bent glass sheets 2 into a lehr 9.

10

As shown in Figure 3, the upper wall 10 of the chamber 7 has a central zone 11 as well as edges zones 12 and 13, the approximate boundary of which is indicated by a dashed boundary line. Edge zones 12 are assigned to the longer sides and edge zones 13 to the shorter sides. The area of central zone 11 roughly corresponds to the sum of the areas of edge zones 12 and
15 13, whereby the boundary of central zone 11 has a course which is geometrically similar to the course of the edge of upper wall 10 of chamber 7.

Nozzles 14 (Figure 5 and 6) pass through upper wall 10 of chamber 7, only the nozzle exit areas 15 of which are shown in Figures 3 and 4. The degree of perforation of central zone 11
20 of wall 10 is smaller than the degree of perforation of edge zones 12 and 13. The degree of perforation is defined within the scope of the invention as the sum of the nozzle exit areas 15 of respective zone 11, 12, 13 in relation to the total area of this zone 11, 12, 13. The ratio of the degree of perforation of central zone 11 to the degree of perforation of edge zones 12 and 13 amounts in the present case to approx. 0.75 with a degree of perforation of the central zone
25 of approx. 0.2.

The device according to the invention produces a uniform gas cushion, whereby the smaller degree of perforation in central zone 11 ensures that the gas can discharge undisturbed via the edge zones. Since nozzles 14 are integrated into wall 10 and discharge openings or slots in
30 wall 10 are dispensed with, no cooling shadows can be formed in glass sheets 2.

The form of embodiment according to Figure 4 differs from that according to Figure 3 by a somewhat different shape and otherwise by the fact that here the ratio of the degree of perforation of central zone 11 to the degree of perforation of edge zones 12 and 13 amounts to

approx. 0.8, and with a degree of perforation of the central zone of approx. 0.25. No cooling shadows can occur here either for the reasons mentioned in connection with Figure 3.

Furthermore, the design of the nozzles 14 themselves also ensures that jet marks are avoided.

5 The first form of embodiment of the nozzle design is shown in Figure 5. According to this, nozzle 14 has an entry bore 22 which widens abruptly in the flow direction and which is followed by an exit hole 16. The entry bore has a first cylindrical section 17, the diameter of which amounts to 4 mm in the present case. This is followed by a second cylindrical section 18 with a diameter of 20 mm. Proceeding from this, exit hole 16 widens conically to its
10 nozzle exit area 15 with a diameter of 60 mm. This nozzle design is able to slow down the gas emerging from first section 17 with a corresponding pressure build-up and to distribute it via exit hole 16, with a further pressure build-up, uniformly over the respective area of the gas cushion.

15 The form of embodiment according to Figure 6 differs from that according to Figure 5 by the fact that first cylindrical section 17 of the entry bore 22 has a diameter of only 3 mm and that, between this section and second cylindrical section 18, there is provided a third cylindrical section 19 with a diameter of 10 mm, whereby short conical transition zones are provided between sections 17 and 19 and, respectively, 19 and 18. The smooth entry of the gas into the
20 gas cushion is further assisted by this nozzle design.

Additionally, Figure 6 shows the arrangement of a cloth 20 made of stainless steel, which serves additionally to render the gas flow uniform and above all to adjust a uniform temperature of the whole lower face of the gas cushion.

25

Chamber 7 is designed as a one-piece moulding made of ceramic. This restricts the minimum achievable diameter of first section 17 of the entry bore of nozzle 14 to approx. 3 mm. Other materials can also be used, possibly with the advantage that the diameter of first section 17 can be reduced further. Moreover, chamber 7 can be heated, in particular by electric heating
30 elements installed close to or in wall 10 of chamber 7. This serves to achieve exact adjustment of the temperature of the gas cushion. The gas originates from a suitable source of compressed gas and is supplied already in the heated state.

WHAT IS CLAIMED IS:

1. A device for producing a cushion of gas for supporting a preheated glass sheet (2), with a chamber (7) connected to a source (21) of compressed gas, the chamber including an upper wall (10) having external dimensions adapted to the outline of the glass sheet (2) and having a plurality of apertures (15) for the passage of gas, characterized in that the apertures are designed as nozzles (14), which have an entry bore (22) as well as a progressively widening exit hole (16), and the upper wall (10) of the chamber (7) has a greater degree of perforation in edge zones (12, 13) of the upper wall than in a central zone (11) of the upper wall.
2. The device according to claim 1, characterized in that the central zone (11) of the upper wall (10) of the chamber (9) roughly corresponds in the magnitude of its area to the sum of the edge zones (12, 13).
3. The device according to claim 1 or 2, having a ratio of the degree of perforation in the central zone (11) of the upper wall (10) of the chamber (7) to the degree of perforation in the edge zones (12, 13) of the upper wall of the chamber of 0.5 to 0.9.
4. The device according to claim 3, characterized in that the ratio of the degree of perforation in the central zone (11) of the upper wall (10) of the chamber (7) to the degree of perforation in the edge zones (12, 13) of the upper wall of the chamber is 0.7 to 0.8.
5. The device according to any one of claims 1 to 4, characterized in that the ratio of the degree of perforation of the upper wall (10) of the chamber (7) in the central zone (11) is at most 0.3.

6. The device according to claim 5, characterized in that the ratio of degree of perforation of the upper wall (10) of the chamber (7) in the central zone (11) is less than 0.25.
7. The device according to any one of claims 1 to 6, wherein the upper wall has longer sides and shorter sides and characterized in that the degree of perforation in the edge zones (12) of the longer sides of the upper wall of the chamber is greater than the degree of perforation in the edge zones (13) of the shorter sides of the upper wall of the chamber.
8. The device according to any one of claims 1 to 7, characterized in that the degree of perforation of the upper wall (10) of the chamber (7) diminishes from a feed side for the glass sheet (2) to a side opposite the feed side for the glass sheet.
9. The device according to any one of claims 1 to 8, characterized in that an entry bore (22) of at least one of the nozzles (14) widens at least once abruptly in a direction of flow of the gas.
10. The device according to claim 9, characterized in that the entry bore (22) of the nozzles (14) has a first section with a diameter of 2 to 4 mm, and has a second section (18) with a diameter of 20 mm, whereby an exit hole (16) is at an end of the second section.
11. The device according to claim 10 wherein the first section has a diameter of 3 mm.
12. The device according to claim 10 or claim 11, characterized in that the entry bore (22) of the nozzles (14) has a third section (19) with a diameter of 10 mm between the first and second sections (17, 18).
13. The device according to claim 12, characterized in that at least the first, the second and the third sections (17, 18, 19) are formed cylindrically.

14. The device according to claim 13, wherein the first, the second and the third sections are formed with a coinciding cylinder axis.

15. The device according to any one of claims 1 to 14, characterized in that the upper wall (10) of the chamber (7) is covered by a thin porous cloth (20) made of heat-resistant material.

16. The device according to claim 15, characterized in that the cloth (20) is made of heat-conductive material.

17. The device according to claim 16, wherein the cloth is made of corrosion-resistant steel.

18. The device according to any one of claims 1 to 17, characterized in that the chamber (7) is made of ceramic material

19. The device according to claim 18, characterized in that the chamber (7) is comprised of a one-piece moulding.

20. The device according to any one of claims 1-19, characterized in that the chamber (7) is provided with heating elements.

1/5

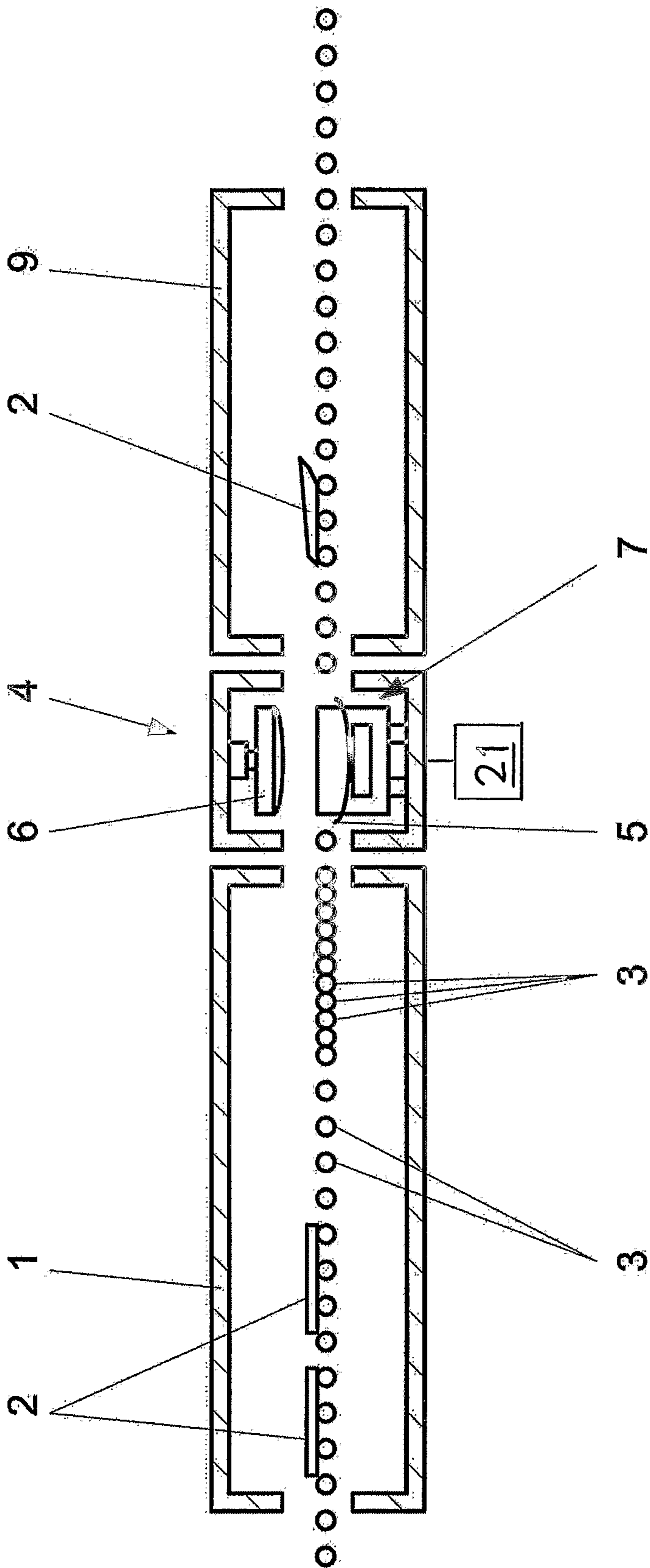

Fig. 1

2/5

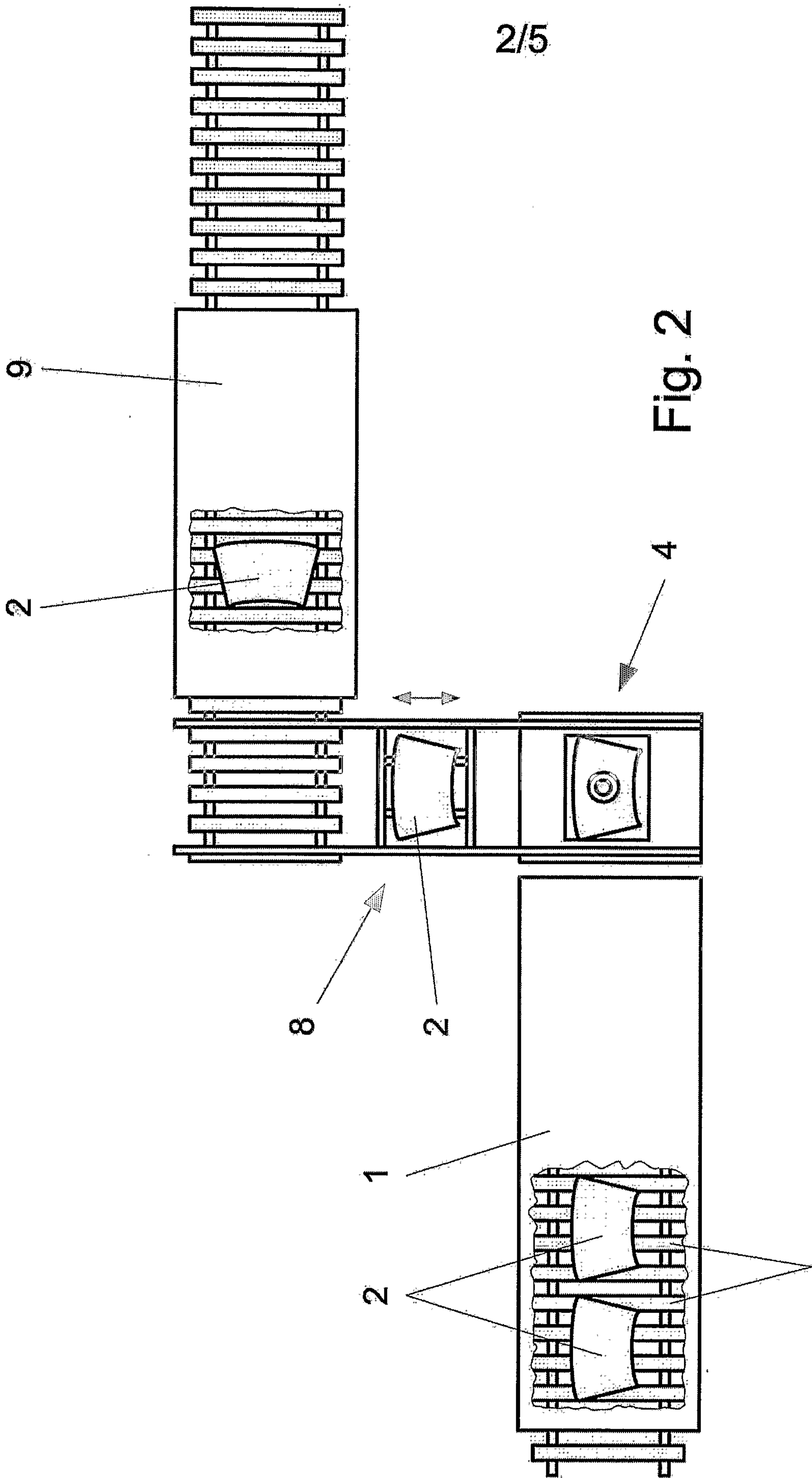

Fig. 2

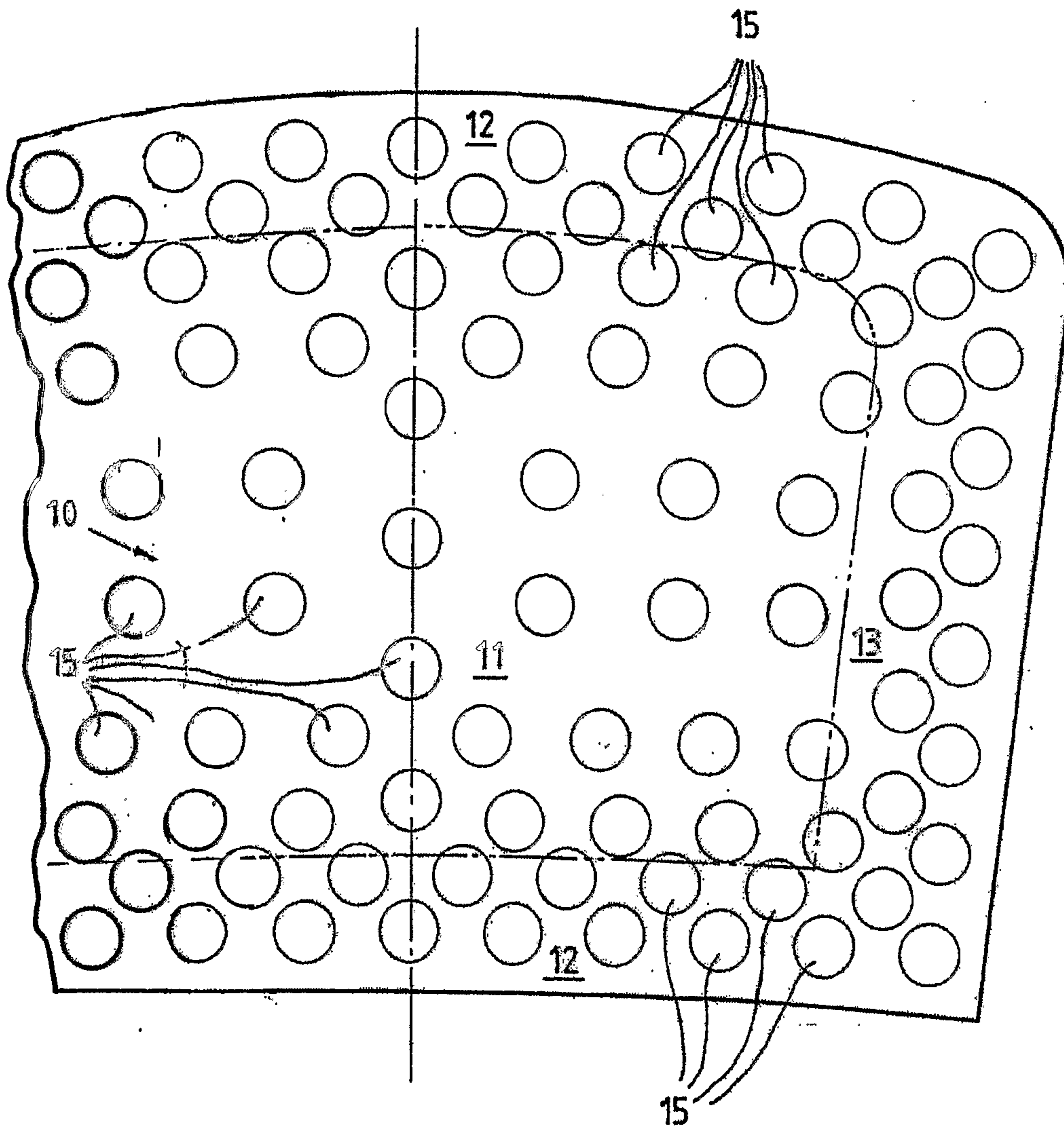

Fig. 3

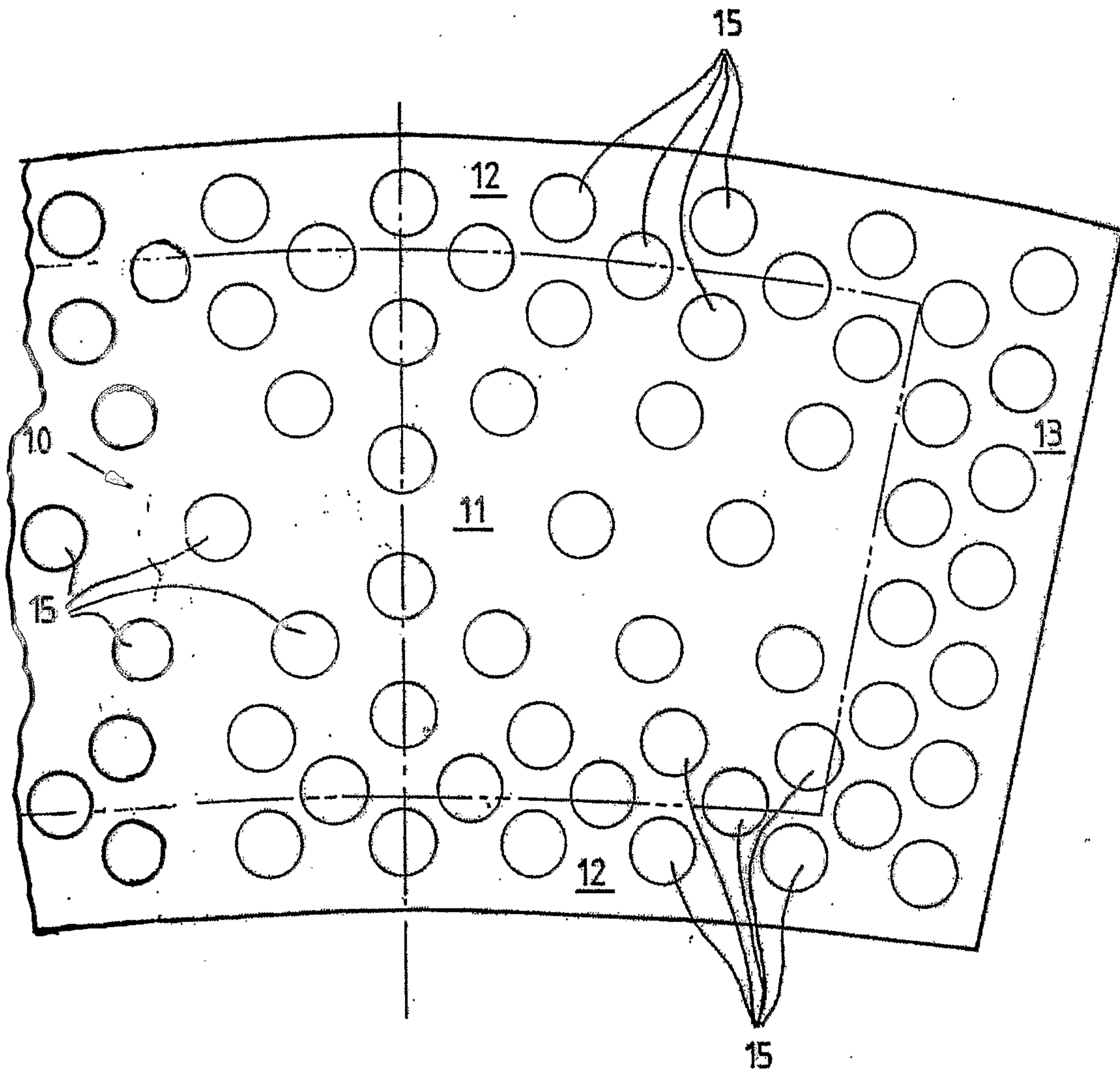

Fig.4

5/5

