

J. J. BURWELL.
MECHANICAL STOKER.
APPLICATION FILED SEPT. 28, 1903.

NO MODEL.

2 SHEETS—SHEET 1.

Fig. 1.

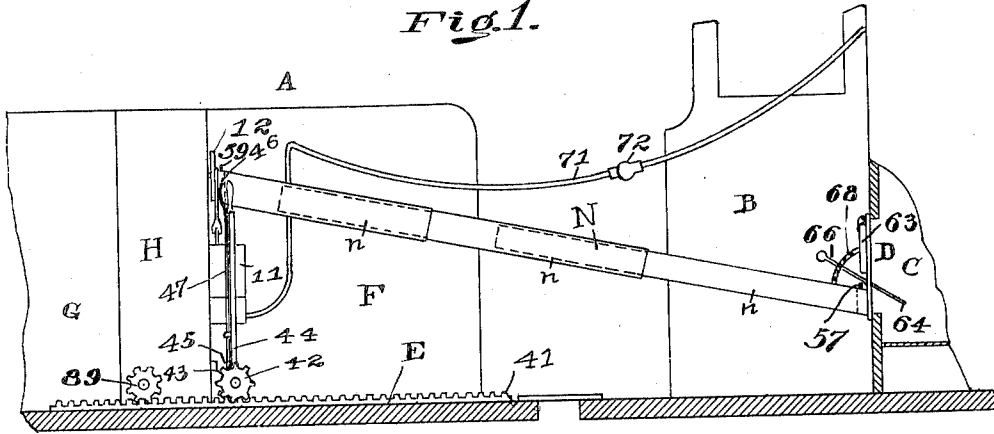

Fig. 2.

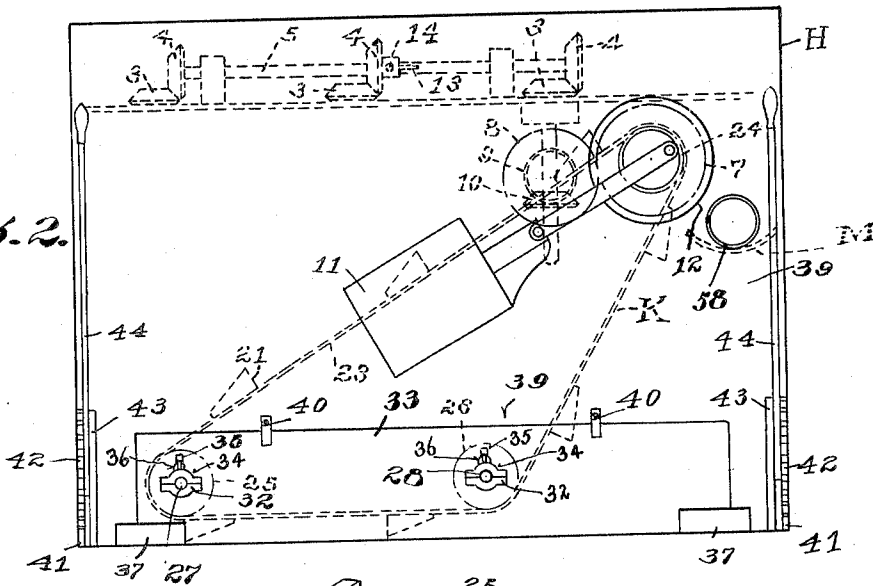

Fig. 3.

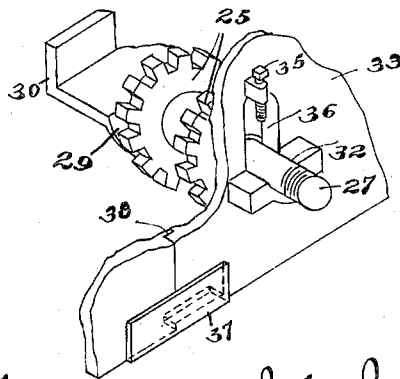
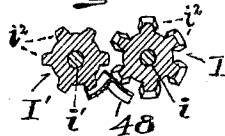

Fig. 11.



Witnesses.

Henry N. Bauer
Herbert P. Norden

Inventor.

John J. Burwell,
by A. D. Verbeke, My Attorney.

J. J. BURWELL.
MECHANICAL STOKER.
APPLICATION FILED SEPT. 28, 1903.

NO MODEL.

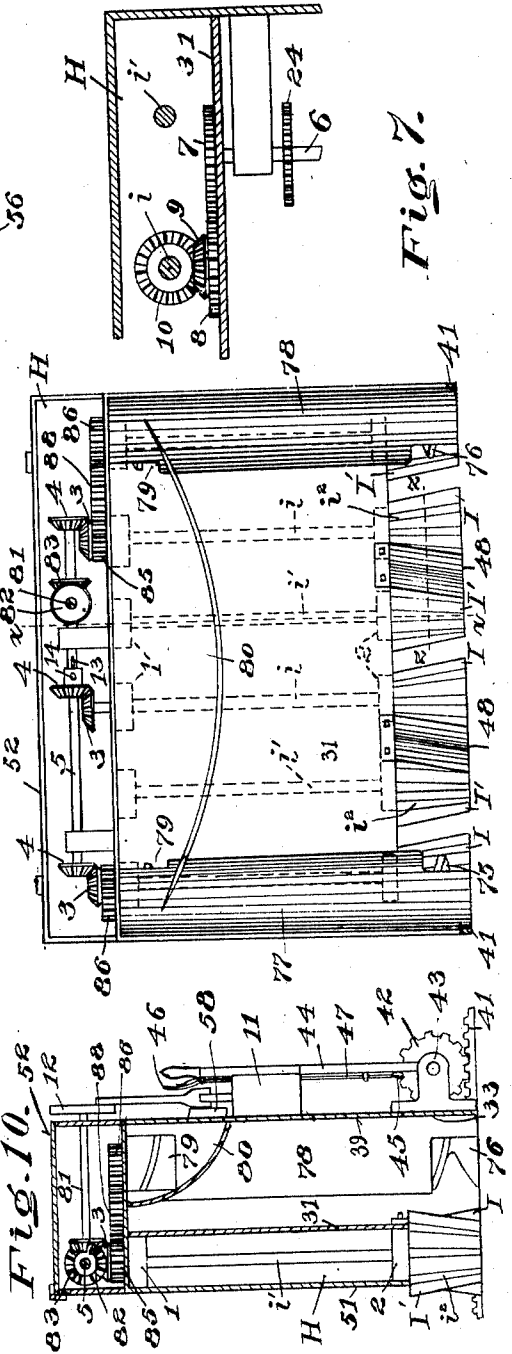
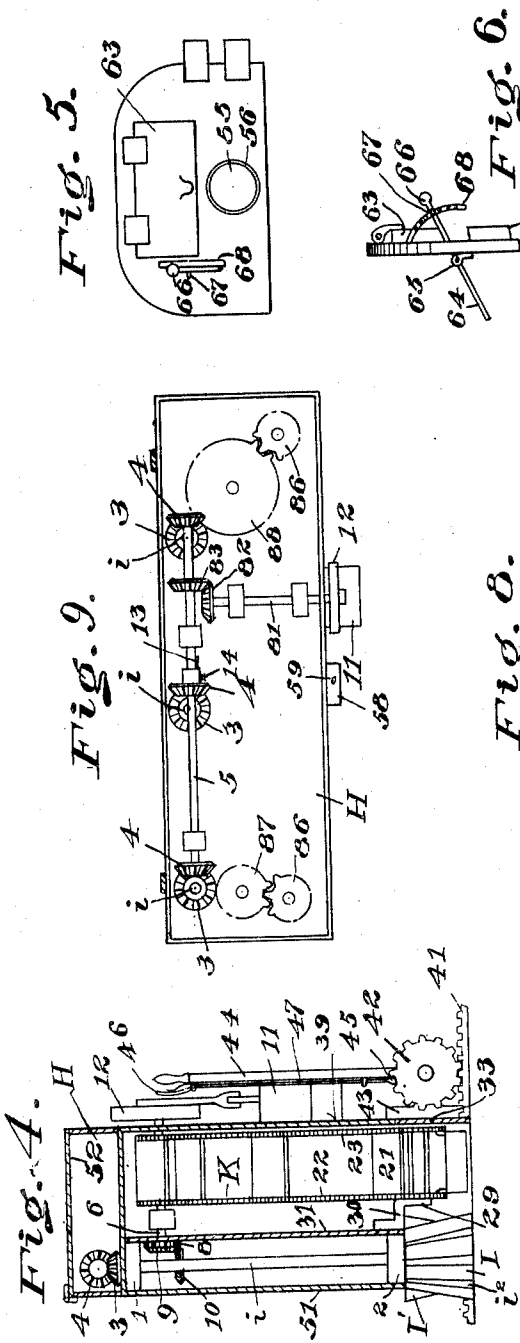

Witnesses.
 Henry N. Bauer
 Herbert T. Harden

Inventor.
 John J. Burwell,
 by T. O. Verbeke, His Attorney

UNITED STATES PATENT OFFICE.

JOHN J. BURWELL, OF CENTRAL COVINGTON, KENTUCKY.

MECHANICAL STOKER.

SPECIFICATION forming part of Letters Patent No. 759,859, dated May 17, 1904.

Application filed September 28, 1903. Serial No. 174,925. (No model.)

To all whom it may concern:

Be it known that I, JOHN J. BURWELL, a citizen of the United States, residing at Central Covington, in the county of Kenton and State of Kentucky, have invented certain new and useful Improvements in Mechanical Stokers, of which the following is a specification.

My invention relates to mechanical stokers, and has for its object the providing of new and improved means whereby the fuel may be fed to the furnace and new and improved means whereby the fuel may be crushed or broken during the feeding operation, and the invention will be readily understood from the following description and claims and from the drawings, in which—

Figure 1 is a side elevation of my improved device shown in connection with a locomotive and tender, parts of the latter being broken away. Fig. 2 is a front elevation of my improved device. Fig. 3 is a perspective view of a detail of the conveyer. Fig. 4 is a side elevation of my improved device with a side of the frame removed for better illustration. Fig. 5 is a front elevation of the fire-box door. Fig. 6 is a side elevation of the same. Fig. 7 is a plan view of a detail of the gearing of the conveyer. Fig. 8 is a front elevation of my improved device, showing a modified form of conveyer with the front plate removed. Fig. 9 is a plan view of the same with the top plate removed. Fig. 10 is a cross-section of the same on the line *xx* of Fig. 8, and Fig. 11 is a detail of the crushers in cross-section on the line *zz* of Fig. 8.

A represents a locomotive-tender; B, a locomotive, of which C is the fire-box, and D the door-opening for the fire-box.

E is the floor of the tender, F its side wall, and G the usual coal or fuel space in the tender.

The tender and locomotive may be of ordinary construction. A frame H is placed in the coal-space and is adapted to support the operative parts of my improved device. These consist, essentially, of crushers *II'*, turned in manner hereinafter explained, a conveyer K, and a feeder N. The frame, box, or casing H is adapted to be placed at the front or fire-box

end of the coal-space in the tender and is arranged to be moved backwardly against the coal as the coal is consumed, so that the crushers may at all times impinge against the coal for feeding it into the conveyer and hopper. I have shown these crushers arranged in pairs at the lower end of shafts *i i'*, journaled in bearing 12 in the frame. The respective shafts *i* have bevel-gears 3 secured thereto, respectively adapted to mesh with bevel-gears 4 on a shaft 5, suitably journaled in the frame. A shaft 6 has a spur-gear 7, meshing a spur-gear 8, on which is a bevel-gear 9, meshing a bevel-gear 10 on one of the shafts *i* for driving the latter and shaft 5. A suitable motor 11, mounted on the frame, drives the shaft 6. 12 is a fly-wheel on the shaft 6, with which the motor connects. The crushers *II'* preferably have ribs *i''* for aiding in the crushing and feeding operation. If desired, one of the bevel-gears 4 may be releasably engaged with its mate 3, as by the spline 13 and set-screw 14, for throwing one of the pair of crushers into or out of operation, thereby regulating the feed of fuel. The crushed fuel is conveyed to a hopper M by means of the conveyers K. The conveyers preferably consist of buckets 21, secured to chains 22 23, taking over sprocket-wheels 24 25 26, mounted, respectively, on the shafts 6 27 28. The sprocket-wheels 24 are driven by the shaft 6, thereby driving the conveyer. The shafts 27 28 are each mounted in a rear bearing 29 in a depending bracket 30, secured to a cross-plate 31 of the frame, and in a front bearing 32 on a door 33, preferably removable. The bearing 32 has a removable cap 34, held in place by a set-screw 35. A slot 36 is provided for permitting looseness of parts when the cap is removed when it is desired to remove the door. The purpose of the door is to provide ready access to the fuel with an ordinary shovel if it is desired to throw the conveyer out of operation. When so thrown out of operation, the shafts 27 28, with their sprocket-wheels, may be removed and the buckets and chains raised out of the way and supported in raised position in any desirable manner. The door may be supported on lugs 37 at the

rear, rest against shoulders 38, and at the top take under the front plate 39 of the frame, suitable hasps 40 holding the door in place.

In order to keep the crushers pressed against the coal, I provide a rack 41 on the tender at each side of the coal-space, a wheel 42, journaled in a bracket 43 on the box, engaging the rack. A lever 44 has a pin 45 engaging between the teeth of the wheel, arranged to be retracted in well-known manner by a grip 46 and connection 47, a spring being provided for normally keeping the pin into engagement with the teeth of wheel 42. If it is desired to press the frame against the coal, the pin is engaged with the teeth of the gear and power applied to the lever for turning the gear, which, traveling on the rack, forces the frame to position. When the pin is in engagement with the teeth, the frame is locked in position on the rack. One of these racks and gears is preferably provided at each side of the box. If desired, a shield 48, supported from the cross-plate 31, may be placed between adjacent pairs of crushers to prevent coal being drawn back into the coal-space. The rear of the frame has a wall 51 for supporting the coal in the tender, thereby forming a gate for the fuel. My improved device thereby serves the function of an ordinary coal-gate on the tender, while serving as a crusher and conveyer. The frame may also have a lid 52, suitably hinged, if desired.

As before stated, the conveyers K discharge into a hopper M, from which a chute N or feeder extends to the fire-box C. The chute N is composed of preferably telescope sections *n*, so that as the box is moved backwardly into the tender the chute may be extended to span the additional distance between the frame and fire-box. The door of the fire-box may be provided with an aperture 55, having a thimble 56 for the end of the chute, through which the coal passes. A releasable connection is made between the door and chute by a pin 57. The hopper is provided with a thimble 58, to which the chute is releasably secured by a pin 59. The door is also provided with a secondary door 63, through which the progress of the fire may be inspected or a poker or other instrument introduced. The door also has a baffle-plate 64 projecting inwardly and downwardly toward the grating of the fire-box for directing the coal downwardly toward the grating. The draft of the locomotive will aid in drawing the coal from the hopper into the fire-box, and the baffle-plate will direct the coal toward the grating of the fire-box. The baffle-plate is preferably hinged, as at 65, a handle 66 projecting outside the door, by means of which the angle of the baffle-plate may be adjusted for directing the coal downwardly toward the front of the fire-box or permitting the coal to spread, thereby further regulating the fire. The baffle-plate is positioned at desired angle by a pin

67, passing through the handle and through selective holes in an arc 68.

In order to drive the motor, I run a flexible steam-pipe 71 from the locomotive to the motor, a releasable connection 72 being placed therein.

In Figs. 8, 9, and 10 I have shown a modified form of conveyer, consisting of spirals 75 76, turning in shells 77 78, each conducting the coal through an opening (shown at 79) into a hopper 80, from which it is conveyed by chute, as already explained. When using the spiral conveyer, I drive the shaft 5 from a shaft 81, to which the fly-wheel 12 is secured, a bevel-gear 82 on the shaft 81 meshing with a bevel-gear 83 on the shaft 5. I drive the spiral conveyers by means of spur-gears 85 on the shafts *i* and spur-gears 86 on the shafts of the spiral conveyers, intermediate spur-gears (shown at 87 and 88, respectively) connecting the gears on the respective shafts *i* and shafts of the spiral conveyers.

I have described my invention in connection with a locomotive and tender; but it is obvious that it can be employed in other relations.

The frame may at each side toward its rear have a wheel 89. The frame rides on these wheels 89 and the wheels 42 for permitting the crushers to just clear the floor of the tender. In practice the coal will when being removed from a full tender first drop from the position next to the frame above the crushers and as the tender is being emptied slant from the rear of the tender toward the crushers, the framing being pressed backwardly against the coal as the coal is consumed.

Having thus fully described my invention, what I claim as new, and desire to secure by Letters Patent, is—

1. In a mechanical stoker, the combination with a coal-receptacle, of a fuel-crusher and a fuel-conveyer arranged in juxtaposition and movable in said coal-receptacle, substantially as described.

2. In a mechanical stoker, the combination with a coal-receptacle, of a fuel-crusher and a fuel-conveyer arranged in juxtaposition, a furnace, an extensible conveyer between said first-named conveyer and said furnace, and means for moving said fuel-crusher and fuel-conveyer in said coal-receptacle, substantially as described.

3. In a mechanical stoker, the combination, with a coal-receptacle, of a fuel-crusher and a conveyer arranged in juxtaposition and movable in said coal-receptacle, a hopper at the end of the fuel-conveyer and a telescope chute projecting from the hopper, substantially as described.

4. In combination with a locomotive and its tender, of a fuel-crusher and a fuel-conveyer movable on the tender, with relation to the body of coal therein, a fire-box on the locomotive, and an elongatable chute between the conveyer and the fire-box.

5. In combination with a locomotive and its tender, of a framing, means for adjustably positioning the framing on the tender, a fuel-crusher and a fuel-conveyer on the framing and movable therewith, and an elongatable chute connecting the framing with the locomotive.
6. In combination with a locomotive and its tender, of a framing forming a fuel-gate, means for adjustably positioning the framing on the tender, a fuel-crusher and a fuel-conveyer on the framing and movable therewith, and an elongatable chute connecting the framing with the locomotive.
7. In a mechanical stoker, the combination of vertically-disposed crushers adapted to be placed adjacent to the floor of the coal-receptacle, a hopper, a bucket conveyer for conveying the coal between the crushers and the hopper, and an elongatable chute, substantially as described.
8. In a mechanical stoker, the combination with the framing, of vertically-disposed crushers mounted in the framing adjacent to its bottom, a hopper in the framing, a bucket conveyer in the framing between the crushers and the hopper, and a telescope chute, substantially as described.
9. In combination, with a locomotive and its tender, said tender having a fuel-space, of a combined movable fuel-gate and fuel-conveyer movable toward and from said locomotive in said fuel-space, substantially as described.
10. In combination with a locomotive and its tender, of a fuel-conveyer located on the tender, an elongatable fuel connection between the tender and the locomotive, a motor on the tender for operating the fuel-conveyer, and releasable flexible connection between said motor and the locomotive for conveying power to said motor.
11. In combination with a locomotive and its tender, of a frame adjustable on the tender, a fuel-crusher and a fuel-conveyer with a motor for driving the same located on and movable with said frame, an elongatable chute between said frame and the locomotive for conveying the coal to the locomotive, and a flexible connection between the locomotive and said motor, for conveying power to said motor.
12. In a mechanical stoker, the combination of the vertically-disposed crushers I' adapted to be placed adjacent to the floor of the coal-receptacle, a hopper, and a conveyer for conveying the coal between the crushers and hopper, substantially as described.
13. In a mechanical stoker, the combination of the vertically-disposed crushers II' adapted to be placed adjacent to the floor of the coal-receptacle and having ribs ϵ^2 , a hopper, and a conveyer for conveying the coal between the crushers and the hopper, substantially as described.
14. In a mechanical stoker, the combination of the vertically-disposed crushers II' adapted to be placed adjacent to the floor of the coal-receptacle, a hopper, a conveyer for conveying the coal between the crushers and hopper, a shaft and gearing for driving said crushers, and means permitting disconnection of driving connection of part of said gearing.
15. In a mechanical stoker, the combination with the locomotive and its tender, of a fuel-crusher adjacent to the floor of said tender, a hopper, a fuel-conveyer from said crusher to said hopper, and an inclined chute between said hopper and the fire-box of the locomotive.
16. In a mechanical stoker, the combination with the locomotive and its tender, of a fuel-crusher adjacent to the floor of said tender, a hopper, a fuel-conveyer from said crusher to said hopper, and an inclined chute between said hopper and the fire-box of the locomotive, and a baffle-plate between the said chute and the fire-box.
17. In a mechanical stoker, the combination with the locomotive and its tender, of a fuel-conveyer operating adjacent to the floor of the tender, a raised hopper on the tender to which said fuel is fed by said conveyer, and an inclined chute from said hopper for conveying said fuel to the fire-box of the locomotive.
18. In a mechanical stoker, the combination with the locomotive and its tender, of a fuel-conveyer operating adjacent to the floor of the tender, a raised hopper to which said fuel is fed by said conveyer, an inclined chute from said hopper for conveying said fuel to the fire-box of the locomotive, and an adjustable baffle-plate between said chute and the fire-box.
19. In a mechanical stoker, the combination of a fuel-receptacle, a fire-box, fuel-crushers extending up and down and arranged side by side, a hopper, a bucket conveyer traveling in front and transversely of said crushers and conveying the fuel from said crushers to said hopper, and a chute between said hopper and the fire-box, substantially as described.
20. In a mechanical stoker, the combination with a locomotive and its tender, of a fuel-conveyer for conveying the fuel from the tender to the locomotive and comprising a chute, and a baffle-plate in the fire-box of the locomotive positioned above the mouth of said chute, and means for adjusting said baffle-plate for depending more or less in front of the mouth of said chute above the fuel passing therethrough for directing the fuel more or less downwardly, substantially as described.

In witness whereof I have signed my name hereto in the presence of two subscribing witnesses.

JOHN J. BURWELL.

Witnesses:

AUGUST F. HERBSLEB,
HENRY N. BAUER.