



(11) **EP 4 180 710 A1**

(12) **EUROPEAN PATENT APPLICATION**

(43) Date of publication:
17.05.2023 Bulletin 2023/20

(51) International Patent Classification (IPC):
F21S 41/147^(2018.01) F21S 41/151^(2018.01)
F21S 41/20^(2018.01)

(21) Application number: **21207916.4**

(52) Cooperative Patent Classification (CPC):
F21S 41/147; F21S 41/151; F21S 41/285;
F21W 2102/155

(22) Date of filing: **12.11.2021**

(84) Designated Contracting States:
AL AT BE BG CH CY CZ DE DK EE ES FI FR GB
GR HR HU IE IS IT LI LT LU LV MC MK MT NL NO
PL PT RO RS SE SI SK SM TR
Designated Extension States:
BA ME
Designated Validation States:
KH MA MD TN

- **Mandl, Bernhard**
04510 Seoul (KR)
- **Krist, Benedikt**
1230 Vienna (AT)
- **Pühringer, Jakob**
3370 Ybbs (AT)

(71) Applicant: **ZKW Group GmbH**
3250 Wieselburg (AT)

(74) Representative: **Patentanwaltskanzlei**
Matschnig & Forsthuber OG
Biberstraße 22
Postfach 36
1010 Wien (AT)

(72) Inventors:
• **Park, Sunjung**
08042 Seoul (KR)

(54) **ILLUMINATION DEVICE FOR A MOTOR VEHICLE HEADLAMP**

(57) Illumination device (10) for a motor vehicle headlamp for generating a low beam light distribution (LB), wherein a vertical extension of the low beam light distribution extends along a V-V-line from at least 0° down to at least -10° on the V-V-line, said illumination device (10) comprises at least one light source (50), an optic body (100) comprising:

- a common light input section (110) for coupling light-rays from the at least one light source (50) into the optic body (100), said common light input section (110) having at least one light collecting element (120), which is assigned to a respective light source (50),
- a light output section (130) for decoupling light-rays that are coupled into the optic body (100) via the common light input section (110), out of the optic body (100) in a main direction (X) of the illumination device (10),
- a projection lens system (200) configured to project the light-rays in front of the illumination device (10), wherein the at least one light collecting element (120) in combination with the optic body (100) allow at least three sets of light-ray paths (LR1, LR2, LR3), wherein the first part of the low beam light distribution (LB1) contributed by light-rays following the first and second light ray paths (LR1, LR2) and the second part of the low beam light distribution (LB2) contributed by light-rays following the third light-ray path (LR3) form the low beam light distribution (LB), wherein the vertical extension of the low beam light distribution (LB) extends along the V-V-line from at least 0° down to at least -10° on the V-V-line.

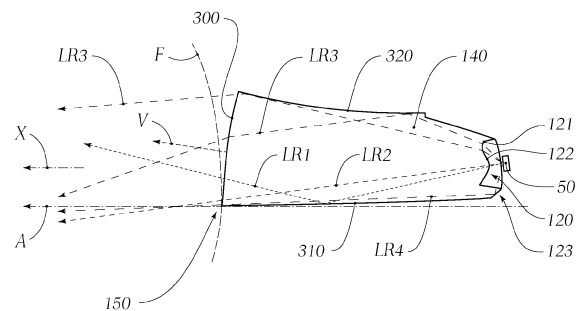

Fig. 2

EP 4 180 710 A1

Description

[0001] The invention relates to an illumination device for a motor vehicle headlamp for generating a low beam light distribution, wherein a vertical extension of the low beam light distribution extends along a V-V-line from at least 0° down to at least -10° on the V-V-line, said illumination device comprises:

- at least one light source configured to emit light-rays,
- an optic body comprising:
 - a common light input section for coupling light-rays from the at least one light source into the optic body, said common light input section having at least one light collecting element, which is assigned to a respective light source and is configured to couple light-rays from the assigned light source into the optic body,
 - a light output section for decoupling light-rays that are coupled into the optic body via the common light input section, out of the optic body in a main direction of the illumination device,
 - a shell surface limiting the optic body, said shell surface is configured to deflect light-rays coupled into the optic body, which shell surface extends between the common light input section and the light output section,
 - a projection lens system, comprising at least one lens, arranged downstream of the optic body along the main direction in order to receive light-rays emitted from the light output section of the optic body, wherein the projection lens system is configured to project the light-rays in front of the illumination device,

wherein the projection lens system in combination with the at least one light source and the optic body are configured to generate the low beam light distribution illuminated by the projections lens system.

[0002] Further, the invention relates to a motor vehicle headlamp comprising at least one illumination device according to the invention.

[0003] In some cases, especially when a high resolution high beam and/or high resolution low beam light distribution is required for a vehicle headlamp, the construction of the corresponding illumination device demands certain requirements that results sometimes in not fulfilling legal requirements on a low beam light distribution (see for example in Official Journal of the EU L 250/92 - 22.08.2014).

[0004] To fulfill also the requirements for the low beam light distribution in view of illumination intensity values and the demanded spatial illumination on a road, an enhanced illumination device is required.

[0005] It is an object of the invention to provide an enhanced illumination device.

[0006] To achieve this object, the at least one light collecting element in combination with the optic body allow at least three sets of light-ray paths,

wherein the optic body comprises a first set of optically operative surfaces for guiding at least part of the light-rays coupled into the optic body via the common light input section along a first light-ray path from the common light input section to the light output section,

wherein the first set of optically operative surfaces comprises a first deflection surface and a light exit surface, wherein the first deflection surface is part of the shell surface and the light exit surface is part of the light output section,

wherein light-rays following the first light-ray path are incident on the first deflection surface and are deflected to the light exit surface for coupling out of the optic body,

and wherein light-rays following a second light-ray path are incident on the light exit surface directly from the common light input section,

wherein light-rays following the first and second light-ray path contribute to generate a first part of the low beam light distribution,

and wherein the optic body comprises a second set of optically operative surfaces for guiding at least part of the light-rays coupled into the optic body via the common light input section along a third light-ray path from the common light input section to the light output section,

wherein the second set of optically operative surfaces comprises a second deflection surface and the light exit surface, wherein the second deflection surface is part of the shell surface and separate from the first deflection surface, and wherein the second deflection surface is - in a correct installed state of the illumination device in a vehicle - a top surface of the optic body and is formed as a concave surface,

5

wherein light-rays following the third light-ray path are incident on the second deflection surface and are deflected to the light exit surface for coupling out of the optic body,

10

and wherein light-rays following the third light-ray path contribute to generate a second part of the low beam light distribution,

15

wherein the first part of the low beam light distribution contributed by light-rays following the first and second light ray paths and the second part of the low beam light distribution contributed by light-rays following the third light-ray path form the low beam light distribution, wherein the vertical extension of the low beam light distribution extends along the V-V-line from at least 0° down to at least -10° on the V-V-line.

[0007] Advantageously, the illumination device comprises at least two light sources, wherein the common light input section comprises at least two light collecting elements each assigned to one light source.

20

[0008] Advantageously, the light sources are arranged in at least one row along a straight horizontal line, wherein the corresponding light collecting elements are arranged in rows along a straight horizontal line, wherein the straight horizontal lines are substantially orthogonal to the main direction.

[0009] Advantageously, the at least one light source is built as a LED.

[0010] Advantageously, the at least one light collecting element is built as TIR-lens.

25

[0011] Advantageously, the light exit surface and the shell surface intersect in a common surface section line, said common surface section line builds an asymmetric cut-off boundary for the low beam light distribution.

[0012] Advantageously, the projection lens system comprises an optical axis and the light exit surface having a surface vector, which surface vector is inclined to the optical axis of the projection lens system.

30

[0013] Advantageously, the projection lens system comprises a curved focal surface, preferably a Petzval-surface, wherein the light exit surface is inclined to the curved focal surface, so that only the common surface section line is arranged in the curved focal surface.

[0014] Advantageously, the surface vector of the light exit surface is - seen in a correctly installed state of the illumination device in a vehicle - inclined upward.

35

[0015] Advantageously, the at least one light collecting element having a curved light input surface for coupling light-rays from the assigned light source into the optic body, wherein the curved light input surface comprises a central section having a convex form.

[0016] Advantageously, the curved light input surface of the at least one light collecting element comprises a first deflection section corresponding to the second deflection surface, wherein the deflection section is configured to deflect light-rays incident on the first deflection section to the second deflection surface.

40

[0017] Advantageously, the first deflection section has a curvature opposite to the curvature of the central section of the light input surface, preferably a concave curvature.

[0018] Advantageously, the at least one light collecting element comprises a second deflection section corresponding to the first deflection surface, wherein the second deflection section is configured to deflect light-rays incident on second the deflection section to the first deflection surface, wherein light rays following a fourth light ray path, when incident on the second deflection section, and wherein the fourth light ray path contributes to the low beam light distribution.

45

[0019] Advantageously, the at least one light source emits light-rays in a light emitting direction, wherein the at least one light source is arranged in a way, that the light emit direction is not parallel to the main direction of the illumination device.

[0020] The term "light emitting direction" is to be understood as a direction, in which the at least one light source emits the most or the strongest light as a result of its directionality - or in other words, where the highest light flux is present.

50

[0021] The object of the invention is also solved by a motor vehicle headlamp comprising at least one illumination device according to the invention.

[0022] The object can also be achieved by a motor vehicle headlamp comprising at least one illumination device according to the invention.

55

[0023] In the following, in order to further demonstrate the present invention, illustrative and non-restrictive embodiments are discussed, as shown in the drawings, which show:

Fig. 1 an isometric view of an example of an illumination device comprising light sources, an optic body in which light-rays of the light sources can be coupled in, and a projection lens, which is configured to project decoupled

light-rays of the optic body in front of the illumination device,

Fig. 2 the optic body of the illumination device of Fig. 1 in a cross-section view, wherein the optic body comprises a light input section and a light output section,

Fig. 3A a detailed view of an example of the light input section of the illumination device of Fig. 1,

Fig. 3B a detailed view of a further example of the light input section of the illumination device of Fig. 1,

Fig. 4 example for a low beam light distribution generated by the illumination device of Fig.1,

Fig. 5 a front view of the light output section of the optic body of the illumination device of Fig. 1, and

Fig. 6 a back view of the light input section of the illumination device of Fig. 1.

[0024] Fig. 1 shows an example of an illumination device **10** for a motor vehicle headlamp for generating a low beam light distribution **LB**, wherein a vertical extension of the low beam light distribution extends along a V-V-line from at least 0° down to at least -10° on the V-V-line, which can be seen in more detail in Fig. 4.

[0025] The illumination device **10** comprises light sources **50** configured to emit light-rays, an optic body **100** comprising a common light input section **110** for coupling light-rays from the light sources **50** into the optic body **100**, wherein the light sources are built as LEDs.

[0026] The common light input section **110** having light collecting elements **120**, each of which is assigned to a respective light source **50** and is configured to couple light-rays from the assigned light source **50** into the optic body **100**.

[0027] Further, the optic body **100** comprises a light output section **130** for decoupling light-rays that are coupled into the optic body **100** via the common light input section **110**, out of the optic body **100** in a main direction **X** of the illumination device **10**.

[0028] The light sources **50** are arranged only in a row along a straight horizontal line, wherein the corresponding light collecting elements **120** are arranged only in a row along a straight horizontal line, wherein the straight horizontal lines are substantially orthogonal to the main direction **X**, which can be seen for example in Fig. 6, which shows a back view of the optic body **100**.

[0029] The optic body **100** also comprises a shell surface **140** limiting the optic body **100** by extending between the common light input section **110** and the light output section **130**, said shell surface **140** is configured to deflect light-rays coupled into the optic body **100**, preferably by total inner reflection.

[0030] The illumination device **10** comprises further a projection lens system **200**, comprising at least one lens (in the shown example exactly one lens), arranged downstream of the optic body **100** along the main direction **X** in order to receive light-rays emitted from the light output section **130** of the optic body **100**, wherein the projection lens system **200** is configured to project the light-rays in front of the illumination device **10**, wherein the projection lens system **200** in combination with the light sources **50** and the optic body **100** are configured to generate the low beam light distribution **LB** illuminated by the projections lens system **200**.

[0031] As can be seen in Fig. 2, the light collecting elements **120** in combination with the optic body **100** allow four sets of light-ray paths **LR1**, **LR2**, **LR3**, **LR4**, wherein the optic body **100** comprises a first set of optically operative surfaces for guiding at least part of the light-rays coupled into the optic body **100** via the common light input section **110** along a first light-ray path **LR1** from the common light input section **110** to the light output section **130**.

[0032] The first set of optically operative surfaces comprises a first deflection surface **310** and a light exit surface **300**, wherein the first deflection surface **310** is part of the shell surface **140** and the light exit surface **300** is part of the light output section **130**.

[0033] Light-rays following the first light-ray path **LR1** are incident on the first deflection surface **310** and are deflected to the light exit surface **300** for coupling out of the optic body **100**, wherein light-rays following a second light-ray path **LR2** are incident on the light exit surface **300** directly from the common light input section **110**, wherein light-rays following the first, second and fourth light-ray path **LR1**, **LR2**, **LR4** contribute to generate a first part of the low beam light distribution, which first part of the low beam light distribution **LB1** can be seen in Fig. 4.

[0034] The optic body **100** comprises a second set of optically operative surfaces for guiding at least part of the light-rays coupled into the optic body **100** via the common light input section **110** along a third light-ray path **LR3** from the common light input section **110** to the light output section **130**.

[0035] The second set of optically operative surfaces comprises a second deflection surface **320** and the light exit surface **300**, wherein the second deflection surface **320** is part of the shell surface **140** and separate from the first deflection surface **310**, and wherein the second deflection surface **320** is - in a correct installed state of the illumination device **10** in a vehicle - a top surface of the optic body **100** and is formed as a concave surface.

[0036] Light-rays following the third light-ray path **LR3** are incident on the second deflection surface **320** and are deflected to the light exit surface **300** for coupling out of the optic body **100**, and wherein light-rays following the third light-ray path **LR3** contribute to generate a second part of the low beam light distribution **LB2**, which can also be seen in **Fig. 4**.

5 [0037] The first part of the low beam light distribution contributed by light-rays following the first and second light ray paths **LR1**, **LR2** and the second part of the low beam light distribution contributed by light-rays following the third light-ray path **LR3** form the low beam light distribution, wherein the vertical extension of the low beam light distribution extends along the V-V-line from at least 0° down to at least -10° on the V-V-line, which can be seen in **Fig. 4**.

10 [0038] Further, the light collecting elements **120** having a curved light input surface for coupling light-rays from the assigned light source **50** into the optic body **100**, wherein the curved light input surface comprises a central section **122** having a convex form, which can be seen in **Fig. 3A**, as well as in **Fig. 3B**, wherein both figures show different embodiments of the illumination device **10** or the optic body **100**.

15 [0039] The curved light input surface of the light collecting elements **120** shown in **Fig. 3B** comprises a first deflection section **121** corresponding to the second deflection surface **320** of the optic body **100**, wherein the deflection section **121** is configured to deflect light-rays incident on the first deflection section **121** to the second deflection surface **320**, wherein the light rays following a third light ray path **LR3**, when incident on the deflection section **121**, and wherein the third light ray path **LR3** contributes to the low beam light distribution.

first deflection section **121** has a curvature opposite to the curvature of the central section **122** of the light input surface, preferably a concave curvature.

20 [0040] The light collecting elements **120** in **Fig. 3B** and also in the shown embodiment in **Fig. 2** comprises a second deflection section **123** corresponding to the first deflection surface **310** of the optic body **100**, wherein the second deflection section **123** is configured to deflect light-rays incident on second the deflection section **123** to the first deflection surface **310**, wherein light rays following a fourth light ray path **LR4**, when incident on the second deflection section **123**, and wherein the fourth light ray path **LR4** contributes to the first part of the low beam light distribution **LB1**.

25 [0041] Further, the light sources **50** emits light-rays in a light emitting direction **X1**, wherein the at least one light source **50** shown in the embodiment in **Fig. 2** and **Fig. 3A**, is arranged in a way, that the light emitting direction **X1** is not parallel to the main direction **X** of the illumination device **10**. In contrast, in the embodiment shown in **Fig. 3A**, the light emitting direction **X1** is parallel to the main direction **X**, wherein the light collecting element **120** shown in **Fig. 3A** is built as TIR-lens, wherein the light collecting element **120** shown in **Fig. 3B** can be seen as modified TIR-lens.

30 [0042] Back to **Fig. 2**, the light exit surface **300** and the shell surface **140** of the optic body **100** intersect in a common surface section line **150**, said common surface section line **150** builds an asymmetric cut-off boundary for the low beam light distribution. The common surface section line **150** can be seen in **Fig. 5**, which shows the optic body **100** in a front view. As can be clearly seen, the common surface section line **150** is configured to generate an asymmetric cut-off boundary in the low beam light distribution.

35 [0043] Further, the projection lens system **200** comprises an optical axis **A** and the light exit surface **300** having a virtual surface vector **V**, which surface vector **V** is inclined to the optical axis **A** of the projection lens system **200**, wherein the surface vector **V** of the light exit surface **300** is - seen in a correctly installed state of the illumination device **10** in a vehicle and shown in **Fig. 2** - inclined upward, so that the light exit surface **300** is facing in an upward direction.

40 [0044] Moreover, the projection lens system **200** comprises a curved focal surface **F**, preferably a Petzval-surface, wherein the light exit surface **300** is inclined to the curved focal surface **F**, so that only the common surface section line **150** is arranged in the curved focal surface **F**.

LIST OF REFERENCE SIGNS

45	Illumination device	10
	Light source	50
	Optic body	100
	Common light input section	110
50	Light collecting element	120
	First deflection section	121
	Central section	122
	Second deflection section	123
55	Light output section	130
	Shell surface	140

(continued)

5
10
15
20

Common surface section line	150
Projection lens system	200
Light exit surface	300
First deflection surface	310
Second deflection surface	320
Optical axis	A
Curved focal surface	F
Light distribution	LB
First part of light distribution	LB1
Second part of light distribution	LB2
Set of light-ray path	LR1, LR2, LR3, LR4
Surface vector	V
Main direction	X
Light emitting direction	X1

25 **Claims**

1. Illumination device (10) for a motor vehicle headlamp for generating a low beam light distribution (LB), wherein a vertical extension of the low beam light distribution (LB) extends along a V-V-line from at least 0° down to at least -10° on the V-V-line, said illumination device (10) comprises:

30
35
40
45

- at least one light source (50) configured to emit light-rays,
- an optic body (100) comprising:
 - a common light input section (110) for coupling light-rays from the at least one light source (50) into the optic body (100), said common light input section (110) having at least one light collecting element (120), which is assigned to a respective light source (50) and is configured to couple light-rays from the assigned light source (50) into the optic body (100),
 - a light output section (130) for decoupling light-rays that are coupled into the optic body (100) via the common light input section (110), out of the optic body (100) in a main direction (X) of the illumination device (10),
 - a shell surface (140) limiting the optic body (100) by extending between the common light input section (110) and the light output section (130), said shell surface (140) is configured to deflect light-rays coupled into the optic body (100),
- a projection lens system (200), comprising at least one lens, arranged downstream of the optic body (100) along the main direction (X) in order to receive light-rays emitted from the light output section (130) of the optic body (100), wherein the projection lens system (200) is configured to project the light-rays in front of the illumination device (10),

50 wherein the projection lens system (200) in combination with the at least one light source (50) and the optic body (100) are configured to generate the low beam light distribution (LB) illuminated by the projections lens system (200), **characterized in that**

55 the at least one light collecting element (120) in combination with the optic body (100) allow at least three sets of light-ray paths (LR1, LR2, LR3), wherein the optic body (100) comprises a first set of optically operative surfaces for guiding at least part of the light-rays coupled into the optic body (100) via the common light input section (110) along a first light-ray path (LR1) from the common light input section (110) to the light output section (130),

wherein the first set of optically operative surfaces comprises a first deflection surface (310) and a light exit surface (300), wherein the first deflection surface (310) is part of the shell surface (140) and the light exit surface (300) is part of the light output section (130),

wherein light-rays following the first light-ray path (LR1) are incident on the first deflection surface (310) and are deflected to the light exit surface (300) for coupling out of the optic body (100),

and wherein light-rays following a second light-ray path (LR2) are incident on the light exit surface (300) directly from the common light input section (110),

wherein light-rays following the first and second light-ray path (LR1, LR2) contribute to generate a first part of the low beam light distribution (LB1),

and wherein the optic body (100) comprises a second set of optically operative surfaces for guiding at least part of the light-rays coupled into the optic body (100) via the common light input section (110) along a third light-ray path (LR3) from the common light input section (110) to the light output section (130),

wherein the second set of optically operative surfaces comprises a second deflection surface (320) and the light exit surface (300), wherein the second deflection surface (320) is part of the shell surface (140) and separate from the first deflection surface (310), and wherein the second deflection surface (320) is - in a correct installed state of the illumination device (10) in a vehicle - a top surface of the optic body (100) and is formed as a concave surface,

wherein light-rays following the third light-ray path (LR3) are incident on the second deflection surface (320) and are deflected to the light exit surface (300) for coupling out of the optic body (100),

and wherein light-rays following the third light-ray path (LR3) contribute to generate a second part of the low beam light distribution (LB2),

wherein the first part of the low beam light distribution (LB1) contributed by light-rays following the first and second light ray paths (LR1, LR2) and the second part of the low beam light distribution (LB2) contributed by light-rays following the third light-ray path (LR3) form the low beam light distribution, wherein the vertical extension of the low beam light distribution (LB) extends along the V-V-line from at least 0° down to at least -10° on the V-V-line.

2. Illumination device according to claim 1, **wherein** the illumination device (10) comprises at least two light sources (50), wherein the common light input section (110) comprises at least two light collecting elements (120) each assigned to one light source (50).
3. Illumination device according to claim 2, **wherein** the light sources (50) are arranged only in a row along a straight horizontal line, wherein the corresponding light collecting elements (120) are arranged only in a row along a straight horizontal line, wherein the straight horizontal lines are substantially orthogonal to the main direction (X).
4. Illumination device according to any one of claims 1 to 3, **wherein** the at least one light source (50) is built as a LED.
5. Illumination device according to any one of claims 1 to 4, **wherein** the at least one light collecting element (120) is built as TIR-lens.
6. Illumination device according to any one of claims 1 to 5, **wherein** the light exit surface and the shell surface (140) intersect in a common surface section line (150), said common surface section line (150) builds an asymmetric cut-off boundary for the low beam light distribution (LB).
7. Illumination device according to any one of claims 1 to 6, **wherein** the projection lens system (200) comprises an optical axis (A) and the light exit surface (300) having a surface vector (V), which surface vector (V) is inclined to the optical axis (A) of the projection lens system (200).
8. Illumination device according to any one of claims 6 to 7, **wherein** the projection lens system (200) comprises a curved focal surface (F), preferably a Petzval-surface, wherein the light exit surface (300) is inclined to the curved focal surface (F), so that only the common surface section line (150) is arranged in the curved focal surface (F).
9. Illumination device according to claim 8, **wherein** the surface vector (V) of the light exit surface (300) is - seen in a correctly installed state of the illumination device (10) in a vehicle - inclined upward.
10. Illumination device according to any one of claim 1 to 9, **wherein** the at least one light collecting element (120) having a curved light input surface for coupling light-rays from the assigned light source (50) into the optic body (100), wherein the curved light input surface comprises a central section (122) having a convex form.

EP 4 180 710 A1

5 11. Illumination device according to claim 10, **wherein** the curved light input surface of the at least one light collecting element (120) comprises a first deflection section (121) corresponding to the second deflection surface (320), wherein the deflection section (121) is configured to deflect light-rays incident on the first deflection section (121) to the second deflection surface (320).

12. Illumination device according to claim 11, **wherein** the first deflection section (121) has a curvature opposite to the curvature of the central section (122) of the light input surface, preferably a concave curvature.

10 13. Illumination device according to claims 11 or 12, **wherein** the at least one light collecting element (120) comprises a second deflection section (123) corresponding to the first deflection surface (310), wherein the second deflection section (123) is configured to deflect light-rays incident on second the deflection section (123) to the first deflection surface (310), wherein light rays following a fourth light ray path (LR4), when incident on the second deflection section (123), and wherein the fourth light ray path (LR4) contributes to the low beam light distribution (LB).

15 14. Illumination device according to any one of the claims 1 to 13, **wherein** the at least one light source (50) emits light-rays in a light emitting direction (X1), wherein the at least one light source (50) is arranged in a way, that the light emitting direction (X1) is not parallel to the main direction (X) of the illumination device (10).

20 15. Motor vehicle headlamp comprising at least one illumination device (10) according to any one of claims 1 to 14.

25

30

35

40

45

50

55

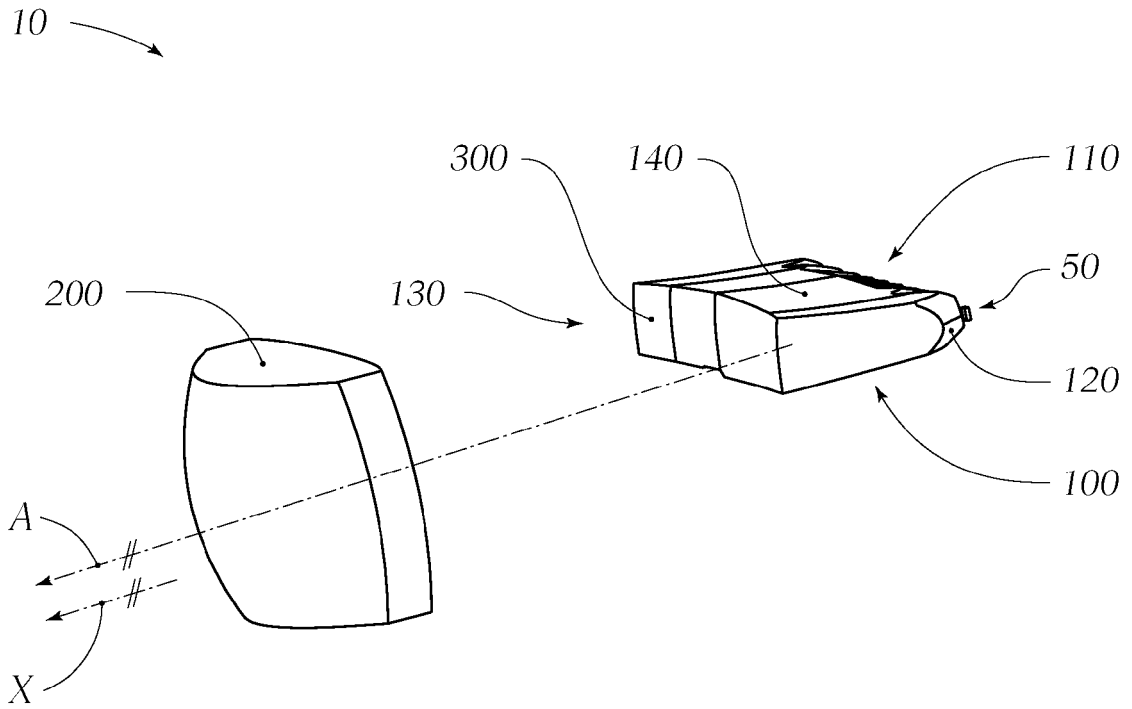

Fig. 1

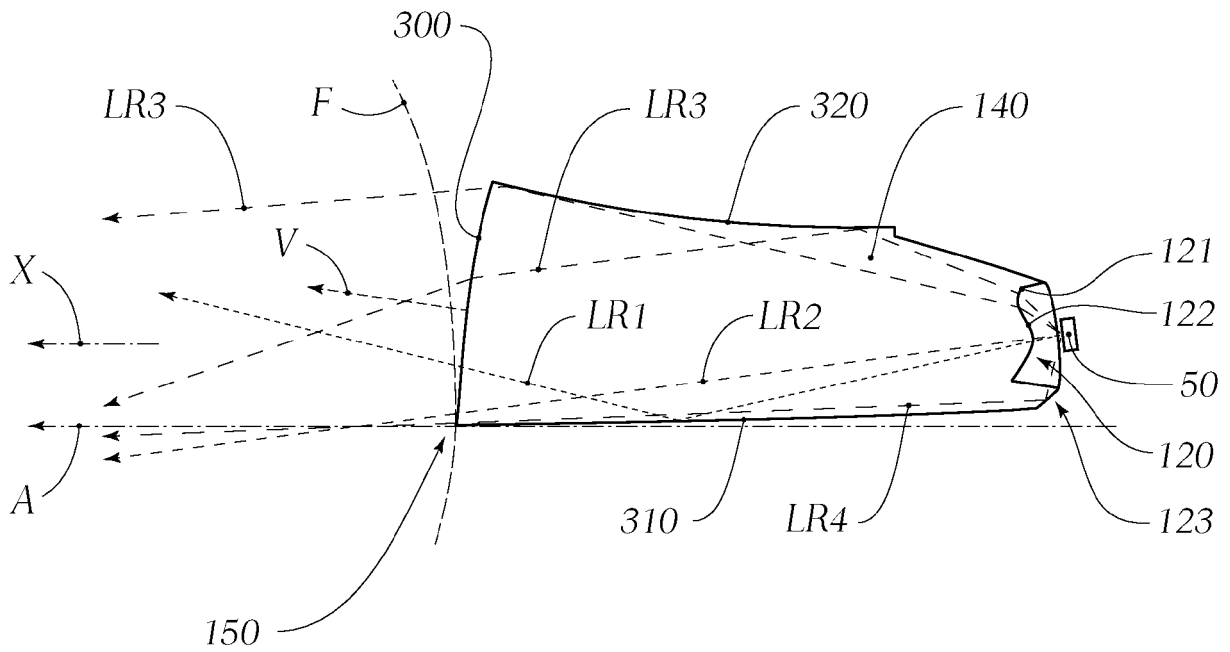

Fig. 2

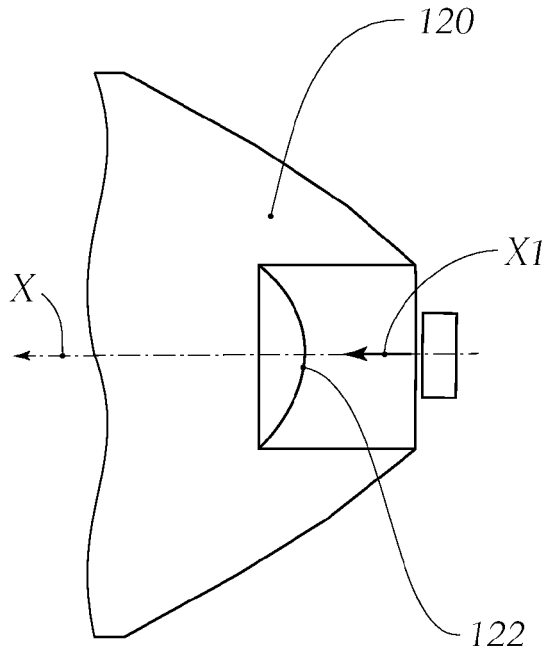

Fig. 3A

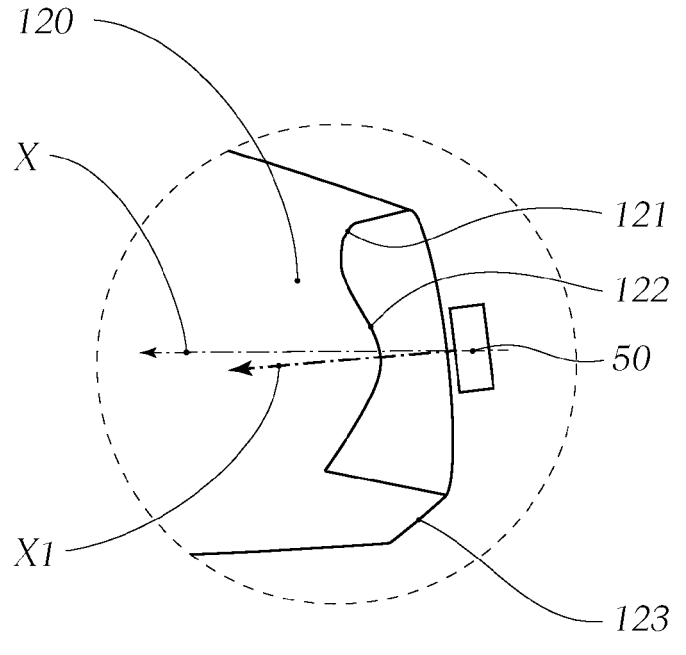

Fig. 3B

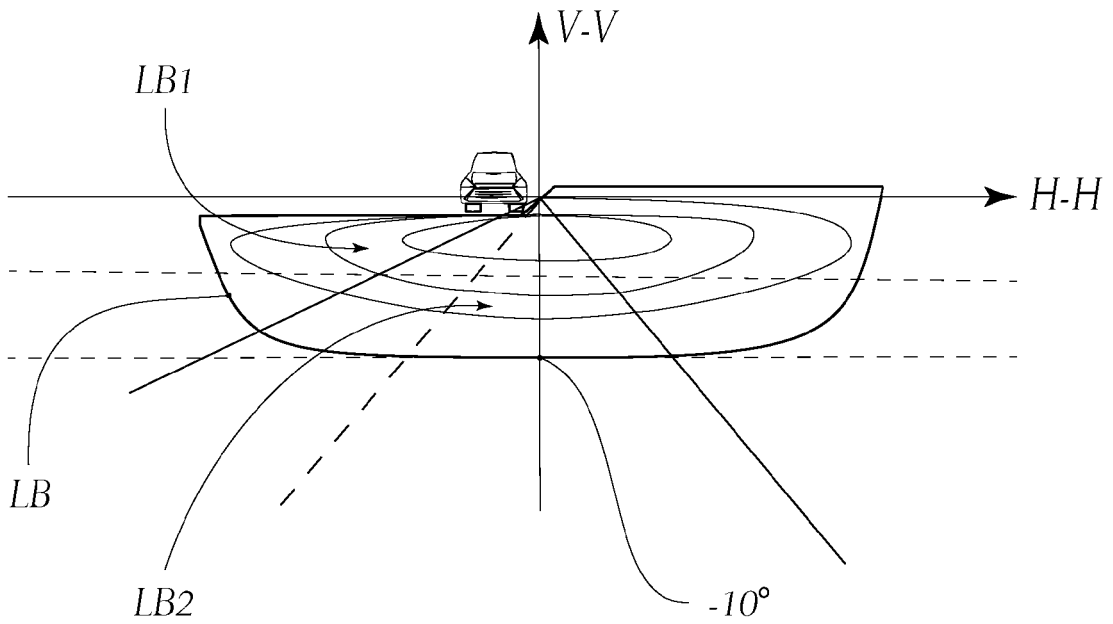

Fig. 4

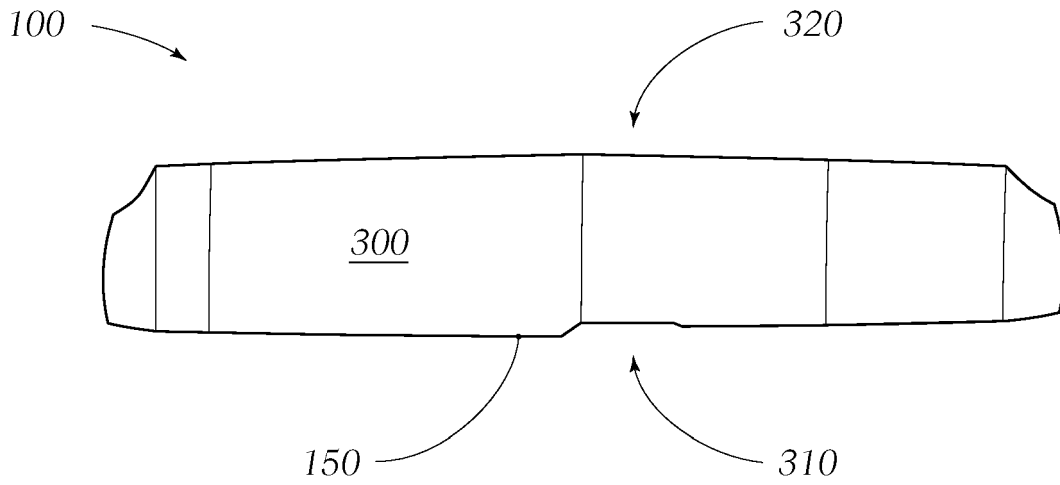

Fig. 5

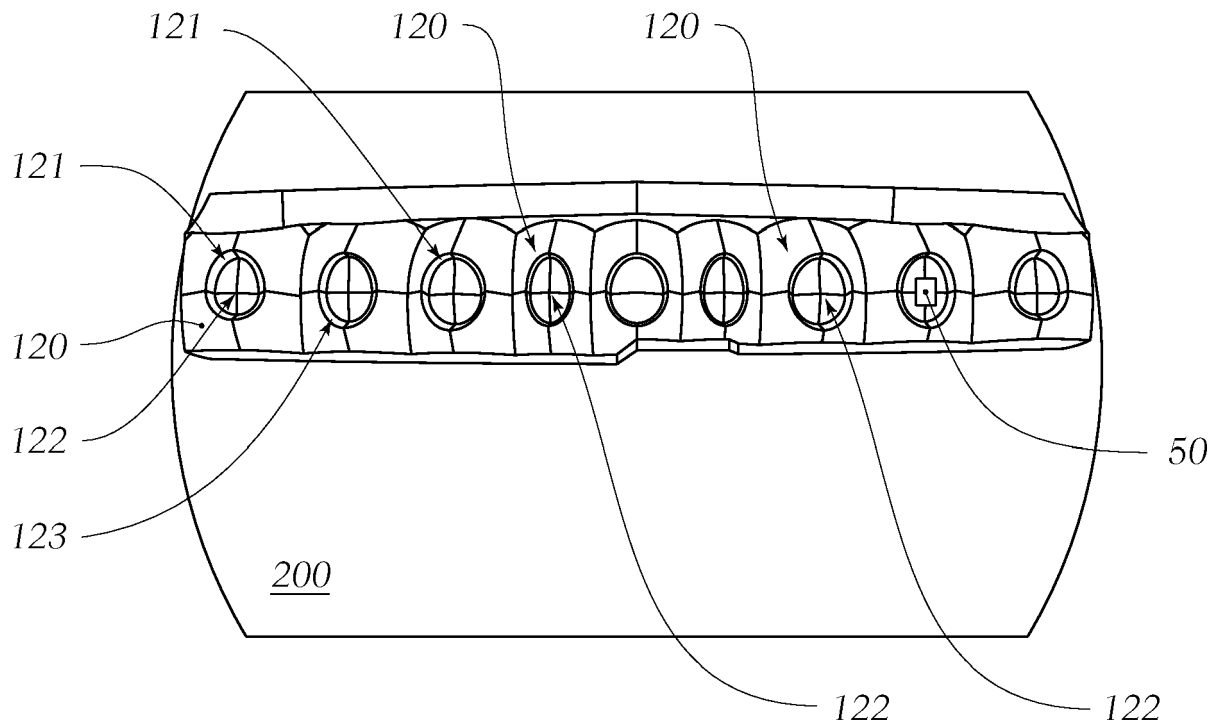

Fig. 6



EUROPEAN SEARCH REPORT

Application Number

EP 21 20 7916

5

10

15

20

25

30

35

40

45

50

55

DOCUMENTS CONSIDERED TO BE RELEVANT			
Category	Citation of document with indication, where appropriate, of relevant passages	Relevant to claim	CLASSIFICATION OF THE APPLICATION (IPC)
X	CN 210 141 552 U (HASCO VISION TECH SHANGHAI CO LTD) 13 March 2020 (2020-03-13)	1-11, 13, 15	INV. F21S41/147 F21S41/151
A	* the whole document * -----	12, 14	F21S41/20
X	DE 20 2017 005367 U1 (HYUNDAI MOBIS CO LTD [KR]) 21 November 2017 (2017-11-21)	1-11, 13, 15	
A	* the whole document * -----	12, 14	
X	DE 10 2020 107075 A1 (DOCTER OPTICS SE [DE]) 16 September 2021 (2021-09-16)	1-8, 10, 11, 13-15	
A	* paragraphs [0033] - [0045]; figures 1-12 * -----	9, 12	
X	EP 3 115 682 A1 (LEXTAR ELECTRONICS CORP [TW]) 11 January 2017 (2017-01-11)	1, 4-11, 13, 15	
A	* paragraphs [0021] - [0052]; figures 1-6 * -----		
A	CN 210 179 513 U (HASCO VISION TECH SHANGHAI CO LTD) 24 March 2020 (2020-03-24)	1-15	TECHNICAL FIELDS SEARCHED (IPC) F21S F21W
A	EP 3 907 427 A1 (HASCO VISION TECH CO LTD [CN]) 10 November 2021 (2021-11-10)	1-15	
	* figures 25-28 * -----		
The present search report has been drawn up for all claims			
Place of search Munich		Date of completion of the search 6 April 2022	Examiner Sarantopoulos, A
CATEGORY OF CITED DOCUMENTS X : particularly relevant if taken alone Y : particularly relevant if combined with another document of the same category A : technological background O : non-written disclosure P : intermediate document		T : theory or principle underlying the invention E : earlier patent document, but published on, or after the filing date D : document cited in the application L : document cited for other reasons & : member of the same patent family, corresponding document	

1
EPO FORM 1503 03:82 (P04C01)

ANNEX TO THE EUROPEAN SEARCH REPORT
ON EUROPEAN PATENT APPLICATION NO.

EP 21 20 7916

5 This annex lists the patent family members relating to the patent documents cited in the above-mentioned European search report.
The members are as contained in the European Patent Office EDP file on
The European Patent Office is in no way liable for these particulars which are merely given for the purpose of information.

06-04-2022

Patent document cited in search report	Publication date	Patent family member(s)	Publication date
CN 210141552 U	13-03-2020	NONE	

DE 202017005367 U1	21-11-2017	CN 207471427 U	08-06-2018
		DE 202017005367 U1	21-11-2017
		JP 6480544 B2	13-03-2019
		JP 2018186068 A	22-11-2018
		KR 101907372 B1	12-10-2018
		US 2018313511 A1	01-11-2018

DE 102020107075 A1	16-09-2021	DE 102020107075 A1	16-09-2021
		WO 2021185411 A1	23-09-2021

EP 3115682 A1	11-01-2017	CN 105066062 A	18-11-2015
		CN 108954212 A	07-12-2018
		EP 3115682 A1	11-01-2017
		JP 6118866 B2	19-04-2017
		JP 2017016990 A	19-01-2017
		TW 201702523 A	16-01-2017
		US 2017009950 A1	12-01-2017
		US 2017009951 A1	12-01-2017

CN 210179513 U	24-03-2020	NONE	

EP 3907427 A1	10-11-2021	CN 213019455 U	20-04-2021
		EP 3907427 A1	10-11-2021
		KR 20210110365 A	07-09-2021
		WO 2020173444 A1	03-09-2020

REFERENCES CITED IN THE DESCRIPTION

This list of references cited by the applicant is for the reader's convenience only. It does not form part of the European patent document. Even though great care has been taken in compiling the references, errors or omissions cannot be excluded and the EPO disclaims all liability in this regard.

Non-patent literature cited in the description

- *Official Journal of the EU*, 22 August 2014, vol. L 250, 92 [0003]