

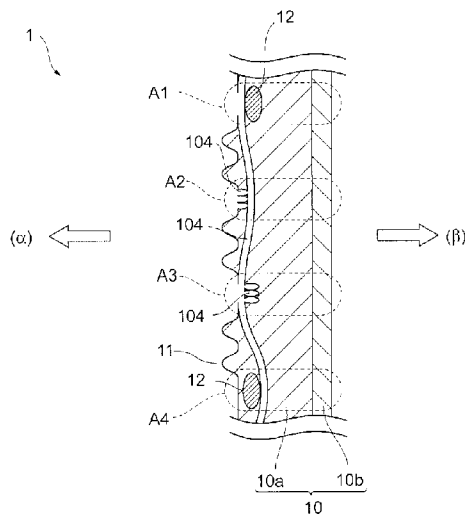

(86) Date de dépôt PCT/PCT Filing Date: 2017/11/24
 (87) Date publication PCT/PCT Publication Date: 2018/08/02
 (45) Date de délivrance/Issue Date: 2021/01/19
 (85) Entrée phase nationale/National Entry: 2018/09/20
 (86) N° demande PCT/PCT Application No.: JP 2017/042291
 (87) N° publication PCT/PCT Publication No.: 2018/139028
 (30) Priorité/Priority: 2017/01/27 (JP2017-013283)

(51) Cl.Int./Int.Cl. *C25B 13/08* (2006.01),
C25B 1/34 (2006.01), *C25B 13/02* (2006.01),
C25B 9/00 (2006.01)
 (72) Inventeurs/Inventors:
 OHASHI, RYUJI, JP;
 KAMEYAMA, HIROYUKI, JP;
 MORIKAWA, TAKUYA, JP
 (73) Propriétaire/Owner:
 ASAHI KASEI KABUSHIKI KAISHA, JP
 (74) Agent: LAVERY, DE BILLY, LLP

(54) Titre : MEMBRANE D'ECHANGE IONIQUE ET APPAREIL D'ELECTROLYSE
 (54) Title: ION EXCHANGE MEMBRANE AND ELECTROLYZER



(57) **Abrégé/Abstract:**

The present invention provides an ion exchange membrane including a layer S including a fluorine-containing polymer having a sulfonic acid group, a layer C including a fluorine-containing polymer having a carboxylic acid group, and a plurality of strengthening materials arranged inside the layer S and functioning as at least one of reinforcement yarn and sacrifice yarn, wherein A and B, both of which are defined below, satisfy following formulas (1) and (2):

$$B \leq 240 \mu\text{m} \dots (1)$$

$$2.0 \leq B/A \leq 5.0 \dots (2)$$

wherein, when the ion exchange membrane is viewed from the top surface,

A represents an average cross-sectional thickness of the membrane measured in pure water for a region, in which the strengthening materials do not exist, and

B represents an average cross-sectional thickness of the membrane measured in pure water for a region, in which strands of the reinforcement yarn overlap with each other, and in a region, in which the reinforcement yarn overlaps with the sacrifice yarn.

Abstract

The present invention provides an ion exchange membrane including a layer S including a fluorine-containing polymer having a sulfonic acid group, a layer C including a fluorine-containing polymer having a carboxylic acid group, and a plurality of strengthening materials arranged inside the layer S and functioning as at least one of reinforcement yarn and sacrifice yarn, wherein A and B, both of which are defined below, satisfy following formulas (1) and (2):

$$B \leq 240 \text{ } \mu\text{m} \dots (1)$$

$$2.0 \leq B/A \leq 5.0 \dots (2)$$

wherein, when the ion exchange membrane is viewed from the top surface,

A represents an average cross-sectional thickness of the membrane measured in pure water for a region, in which the strengthening materials do not exist, and

B represents an average cross-sectional thickness of the membrane measured in pure water for a region, in which strands of the reinforcement yarn overlap with each other, and in a region, in which the reinforcement yarn overlaps with the sacrifice yarn.

ION EXCHANGE MEMBRANE AND ELECTROLYZER

Technical Field

[0001]

The present invention relates to an ion exchange membrane and an electrolyzer. The present invention specifically relates to an ion exchange membrane and an electrolyzer used for alkali chloride salt electrolysis.

Background Art

[0002]

Fluorine-containing ion exchange membranes, which have excellent heat resistance and chemical resistance, are used as electrolytic diaphragms for alkali chloride electrolysis, ozone generation electrolysis, fuel cells, water electrolysis, and hydrochloric acid electrolysis in various applications, further extending to new applications.

[0003]

Of these, in alkali chloride electrolysis for producing chlorine and alkali hydroxide, ion exchange membrane methods have been predominant recently. Additionally, in order to reduce the electric power consumption rate, natural-circulation zero-gap electrolyzers including an ion exchange membrane, an anode, and a cathode in close contact one another have

- 2 -

become predominant for alkali chloride electrolysis by ion exchange membrane methods. For ion exchange membranes used in alkali chloride electrolysis, required are various capabilities. Examples of the capabilities required include an ability to carry out electrolysis at high current efficiency and a low electrolytic voltage, a low concentration of impurities (particularly, alkali chloride and the like) contained in alkali hydroxide generated, high mechanical strength of the membrane, and high chemical resistance against chlorine and alkali hydroxide generated in electrolysis. Of these, reduction in the electrolytic voltage is intensively required while high mechanical strength is maintained.

[0004]

In response to the requirements described above, the shape of the reinforcing core material is controlled to improve the electrolytic voltage while the high mechanical strength is maintained. For example, in Patent Literatures 1 and 2, suppression of the shielding effect caused by reinforcement yarn inside the ion exchange membrane by improving the arrangement and number of strands of the sacrifice yarn to be mix-woven in the reinforcing core material has been carried out to thereby reduce the electrolytic voltage while the high mechanical strength is retained.

- 3 -

Citation List

Patent Literature

[0005]

Patent Literature 1 Japanese Patent No. 5792843

Patent Literature 2 International Publication No. WO
2016/076325

Summary of Invention

Technical Problem

[0006]

With respect to the techniques described in Patent Literatures 1 and 2, although reduction in the electrolytic voltage caused by reduced shielding of ions due to elution holes formed by sacrifice yarn is observed, there is still further room for improvement in ion exchange resins themselves forming the ion exchange membrane and increase in the electrolytic voltage caused by adsorption of gas generated on electrolysis, especially in alkali chloride electrolysis using a natural-circulation zero-gap electrolyzer.

[0007]

The present invention has been made in view of the above problems possessed by the conventional art, and it is an object of the present invention to provide an ion exchange membrane having a reduced electrolytic voltage in alkali chloride electrolysis by means of a natural-

circulation zero-gap electrolyzer while high mechanical strength is retained.

Solution to Problem

[0008]

As a result of intensive studies to solve those problems, the present inventors have found that, when an ion exchange membrane has a predetermined structure and the shape of each part of the ion exchange membrane is adjusted within a specific range, the electrolytic voltage is dramatically reduced while the mechanical strength is retained, thereby having completed the present invention.

[0009]

That is, the present invention is as follows.

[1]

An ion exchange membrane comprising:

a layer S comprising a fluorine-containing polymer having a sulfonic acid group;

a layer C comprising a fluorine-containing polymer having a carboxylic acid group; and

a plurality of strengthening materials arranged inside the layer S and functioning as at least one of reinforcement yarn and sacrifice yarn;

wherein A and B, both of which are defined below, satisfy following formulas (1) and (2):

- 5 -

$$B \leq 240 \mu\text{m} \dots (1)$$

$$2.0 \leq B/A \leq 5.0 \dots (2)$$

wherein, when the ion exchange membrane is viewed from a top surface,

A represents an average cross-sectional thickness of the membrane measured in pure water for a region, in which the strengthening materials do not exist, and

B represents an average cross-sectional thickness of the membrane measured in pure water for a region, in which strands of the reinforcement yarn overlap with each other, and for a region, in which the reinforcement yarn overlaps with the sacrifice yarn.

[2]

The ion exchange membrane according to [1], wherein A and C1 which is defined below satisfy following formula (3):

$$40 \mu\text{m} \leq A \leq C1 \dots (3)$$

wherein C1 represents a maximum value of a distance between a surface of the layer S and reinforcement yarn most distant from the surface of the layer S, the distance being measured in pure water and in a direction of the thickness of the membrane in the region, in which strands of the reinforcement yarn overlap with each other.

[3]

The ion exchange membrane according to [1] or [2], wherein

the layer S has a continuous hole therein and a plurality of opening portions on the surface thereof, and a ratio of a total area of the opening portions in an area of the surface of the layer S is 0.4 to 15%.

[4]

The ion exchange membrane according to any of [1] to [3], wherein the surface of the layer S has raised portions having a height of 20 μm or more, when viewed from a cross section.

[5]

The ion exchange membrane according to [4], wherein an arrangement density of the raised portions is 20 to 1500 raised portions/ cm^2 .

[6]

An electrolyzer comprising the ion exchange membrane according to any of [1] to [5].

Advantageous Effects of Invention

[0010]

The ion exchange membrane of the present invention provides high mechanical strength and a low electrolytic voltage.

Brief Description of Drawings

[0011]

[Figure 1] Figure 1 illustrates a schematic cross-sectional view showing one exemplary ion exchange membrane according to the present embodiment.

[Figure 2] Figure 2 illustrates a simplified perspective view showing one exemplary ion exchange membrane according to the present embodiment, partially cut out, to be used for illustrating an arrangement of opening portions and continuous holes.

[Figure 3] Figure 3 illustrates a simplified perspective view showing one exemplary ion exchange membrane according to the present embodiment, partially cut out, to be used for illustrating an arrangement of reinforcement yarn.

[Figure 4] Figure 4 illustrates a schematic top view showing one exemplary measurement position of the thickness of the membrane according to the present embodiment.

[Figure 5] Figure 5 illustrates a schematic cross-sectional view showing one exemplary measurement position of the thickness a of the ion exchange membrane according to the present embodiment.

[Figure 6] Figure 6 illustrates a schematic cross-sectional view showing one exemplary measurement position of the thickness a of the ion exchange membrane according to the present embodiment.

[Figure 7] Figure 7 illustrates a schematic cross-sectional view showing one exemplary measurement position of the thickness b of the ion exchange membrane according to the present embodiment.

[Figure 8] Figure 8 illustrates a schematic cross-sectional view showing one exemplary measurement position of the thickness b of the ion exchange membrane according to the present embodiment.

[Figure 9] Figure 9 illustrates a schematic cross-sectional view showing one exemplary measurement position of the thicknesses c_1 and c_2 of the ion exchange membrane according to the present embodiment.

[Figure 10] Figure 10 illustrates a schematic cross-sectional view showing one exemplary measurement position of the thicknesses c_1 and c_2 of the ion exchange membrane according to the present embodiment.

[Figure 11] Figure 11 illustrates a partial enlarged view of a region A1 in Figure 1.

[Figure 12] Figure 12 illustrates a partial enlarged view of a region A2 in Figure 1.

[Figure 13] Figure 13 illustrates a partial enlarged view of a region A3 in Figure 1.

[Figure 14] Figure 14 illustrates a conceptual view for illustrating the aperture ratio of the ion exchange membrane according to the present embodiment.

[Figure 15] Figure 15 illustrates a schematic cross-sectional view of a second embodiment of the ion exchange membrane according to the present embodiment.

[Figure 16] Figure 16 illustrates a schematic view for illustrating the exposed area ratio of the ion exchange membrane according to the present embodiment.

[Figure 17] Figure 17 illustrates a schematic cross-sectional view of a third embodiment of the ion exchange membrane according to the present embodiment.

[Figure 18] Figure 18 illustrates a schematic cross-sectional view of a fourth embodiment of the ion exchange membrane according to the present embodiment.

[Figure 19] Figure 19 illustrates a schematic view for illustrating a method for forming continuous holes of the ion exchange membrane according to the present embodiment.

[Figure 20] Figure 20 illustrates a schematic view showing one exemplary electrolyzer according to the present embodiment.

Description of Embodiments

[0012]

Hereinafter, an embodiment for carrying out the present invention (hereinafter, referred to as "the present embodiment") will be described in detail. The present invention is not intended to be limited to the following present embodiment and may be variously

modified and carried out within the spirit thereof. The positional relation such as up and down, left and right, or the like is based upon the positional relation shown in the figures unless otherwise indicated. Furthermore, a size ratio in the figures is not limited to the ratio as illustrated.

[0013]

[Ion exchange membrane]

An ion exchange membrane according to a first aspect of the present embodiment (hereinafter, simply also referred to as a "first ion exchange membrane") comprises a layer S comprising a fluorine-containing polymer having a sulfonic acid group, a layer C comprising a fluorine-containing polymer having a carboxylic acid group, and a plurality of strengthening materials arranged inside the layer S and functioning as at least one of reinforcement yarn and sacrifice yarn. Additionally, A and B, both of which are defined below, satisfy following formulas (1) and (2):

$$B \leq 240 \text{ } \mu\text{m} \dots (1)$$

$$2.0 \leq B/A \leq 5.0 \dots (2)$$

wherein, when the ion exchange membrane is viewed from the top surface,

A represents an average cross-sectional thickness of the membrane measured in pure water for a region, in which the strengthening materials do not exist, and

B represents an average cross-sectional thickness of the membrane measured in pure water for a region, in which strands of the reinforcement yarn overlap with each other, and for a region, in which the reinforcement yarn overlaps with the sacrifice yarn.

By having the configuration as described above, the ion exchange membrane according to the present embodiment can provide high mechanical strength and a low electrolytic voltage.

Additionally, an ion exchange membrane according to a second aspect of the present embodiment (hereinafter, also simply referred to as a "second ion exchange membrane") comprises a layer S comprising a fluorine-containing polymer having a sulfonic acid group, a layer C comprising a fluorine-containing polymer having a carboxylic acid group, and a plurality of strengthening materials arranged inside the layer S and functioning as at least one of reinforcement yarn and sacrifice yarn, wherein A, B, and C1, all of which are defined below, satisfy following formulas (1'), (2), and (3):

$$B < 245 \mu\text{m} \dots (1')$$

$$2.0 \leq B/A \leq 5.0 \dots (2)$$

$$40 \mu\text{m} \leq A \leq C1 \dots (3)$$

wherein, when the ion exchange membrane is viewed from the top surface,

- 12 -

A represents an average cross-sectional thickness of the membrane measured in pure water for a region, in which the strengthening materials do not exist,

B represents an average cross-sectional thickness of the membrane measured in pure water for a region, in which strands of the reinforcement yarn overlap with each other, and for a region, in which the reinforcement yarn overlaps with the sacrifice yarn, and

C1 represents the maximum value of the distance between the surface of the layer S and reinforcement yarn most distant from the surface of the layer S, the distance being measured in pure water and in the direction of the thickness of the membrane in the region, in which strands of the reinforcement yarn overlap with each other.

An ion exchange membrane configured as described above also can provide high mechanical strength and a low electrolytic voltage.

A reference to an "ion exchange membrane according to the present embodiment" hereinafter includes the first ion exchange membrane and the second ion exchange membrane.

[0014]

Figure 1 illustrates a schematic cross-sectional view showing one exemplary ion exchange membrane according to the present embodiment. Figure 2 illustrates a simplified perspective view showing one

exemplary ion exchange membrane according to the present embodiment, partially cut out, to be used for illustrating an arrangement of opening portions and continuous holes. Figure 3 illustrates a simplified perspective view showing one exemplary ion exchange membrane according to the present embodiment, partially cut out, to be used for illustrating an arrangement of reinforcement yarn. Figures 2 and 3 omit raised portions mentioned below.

An ion exchange membrane 1 shown in Figure 1 has a membrane main body 10 constituted of a layer S comprising a fluorine-containing polymer having a sulfonic acid group (10a) and a layer C comprising a fluorine-containing polymer having a carboxylic acid group (10b), and reinforcement yarn (strengthening material) 12 arranged inside the layer S (10a).

In Figure 1, a plurality of raised portions 11 and a plurality of opening portions 102 are formed on the surface of the layer S (10a), and continuous holes 104 for connecting at least two of the opening portions 102 with each other are formed inside the layer S (10a). Holes 106 in Figure 2 are formed by being cut out from the ion exchange membrane 1.

[0015]

[Average cross-sectional thickness of membrane A]

The average cross-sectional thickness of membrane A is calculated as follows.

The position represented by "○" in Figure 4 corresponds to the center of a region, in which neither reinforcement yarn nor sacrifice yarn constituting a reinforcement material exists (a window portion) when the ion exchange membrane is viewed from the top surface, and thickness a is measured at this position. The thickness a , as shown in Figure 5 or Figure 6, corresponds to a thickness of the membrane measured in pure water, at this position and in the cross-sectional direction of the membrane. When raised portions formed only of an ion exchange resin, which constitutes the ion exchange membrane, exist on the surface of the layer S, the distance from the surface of the layer C to the base of the raised portions is taken as the thickness a .

As for a method for measuring the thickness a , a slice having a width of about 100 μm may be cut off from a cross section of a target portion of the ion exchange membrane immersed in pure water in advance, by means of a razor or the like, subsequently the slice may be immersed in pure water with its cross section facing upward, and then the thickness of the slice may be measured using a microscope or the like. Alternatively, a tomographic image of a target portion of the ion exchange membrane immersed in pure water observed using X-ray CT or the like may be used to measure the thickness.

- 15 -

The thickness a was measured at 15 points, and the thickness of the portion having the smallest thickness is taken as a (min).

a (min) is determined at three different positions, and the average value thereof is the thickness A .

From the viewpoint of securing sufficient membrane strength, in the first ion exchange membrane, the thickness A is preferably 40 μm or more, more preferably 50 μm or more. In the second ion exchange membrane, the thickness A is 40 μm or more, preferably 50 μm or more.

The thickness A can be within the aforementioned preferred range by, for example, controlling the thickness each of the layer S and the layer C , or alternatively by setting production conditions (temperature conditions and extension ratio) on production of the ion exchange membrane (in particular, on lamination of the film and strengthening material) within an appropriate range described below or the like. More specifically, when the film temperature on lamination is increased, the thickness A tends to be smaller. When the extension ratio on extension is reduced, the thickness A tends to be larger. The temperature conditions on lamination and the extension ratio on extension are not limited to those described above and preferably adjusted as appropriate, in consideration of the flow characteristics and the like of a fluorine-containing polymer to be used.

[0016]

[Average cross-sectional thickness of membrane B]

The average cross-sectional thickness of membrane B is calculated as follows.

The position represented by " Δ " in Figure 4 corresponds to the region, in which strands of the reinforcement yarn constituting a strengthening material overlap with each other, and the position represented by " \square " in Figure 4 corresponds to the region, in which the reinforcement yarn overlaps with the sacrifice yarn, the both yarn constituting a strengthening material. At both of the positions, thickness b is measured. The thickness b , as shown in Figure 7 or Figure 8, corresponds to the thickness of the membrane measured in pure water for a point having the largest thickness in this region in the cross-sectional direction of the membrane. When raised portions formed only of an ion exchange resin, which constitutes the ion exchange membrane, exist on the surface of the layer S, the distance from the surface of the layer C to the base of the raised portions is taken as the thickness b . The example shown in Figure 8 corresponds to a case in which raised portions formed of an ion exchange resin constituting the ion exchange membrane and a strengthening material exist on the surface of the layer S, and the distance from the surface of the layer C to the tip of the raised portions is taken as the thickness b .

- 17 -

As for a method for measuring the thickness b , a slice having a width of about $100\ \mu\text{m}$ may be cut off from a cross section of a target portion of an ion exchange membrane immersed in pure water in advance, by means of a razor or the like, subsequently the slice may be immersed in pure water with its cross section facing upward, and then the thickness of the slice may be measured using a microscope or the like. Alternatively, a tomographic image of a target portion of an ion exchange membrane immersed in pure water observed using X-ray CT or the like may be used to measure the thickness.

The thickness b was measured at 15 points, and the thickness of the portion having the largest thickness is taken as b (max).

b (max) is determined at three different positions, and the average value thereof is the thickness B .

In alkali chloride electrolysis using a zero-gap electrolyzer, the distance between the electrodes is determined by the thickness of the ion exchange membrane. Thus, when the average cross-sectional thickness of membrane B is large, the resistance between electrodes tends to increase to thereby lead to an increase in the electrolytic voltage. From such a viewpoint, in the first ion exchange membrane, the thickness B is $240\ \mu\text{m}$ or less, preferably $230\ \mu\text{m}$ or less, more preferably $220\ \mu\text{m}$ or less. In the second ion exchange membrane, the relation between A and C mentioned below has been

desirably adjusted. Thus, the thickness B can be less than 245 μm , is preferably 240 μm or less, more preferably 230 μm or less, still more preferably 220 μm or less.

The thickness B can be within the aforementioned preferred range by, for example, controlling the thickness each of the layer S and the layer C or alternatively by setting the diameter of the strengthening material and the production conditions (temperature conditions and extension ratio) on production of the ion exchange membrane (in particular, on lamination of a film and a strengthening material) within an appropriate range described below or the like. More specifically, when the outside air temperature on lamination is lowered, the thickness B tends to be smaller. When the extension ratio on extension is reduced, the thickness B tends to be larger. The temperature conditions on lamination and the extension ratio on extension are not limited to those described above and preferably adjusted as appropriate, in consideration of the flow characteristics and the like of a fluorine-containing polymer to be used.

[0017]

[Thickness ratio B/A]

A thickness ratio B/A is a value obtained by dividing the average cross-sectional thickness of

membrane B by the average cross-sectional thickness of membrane A.

When B/A is increased, the thickness of a window portion through which cations permeate becomes smaller to enable the electrolytic voltage to be reduced. Accordingly, in the ion exchange membrane according to the present embodiment, B/A is 2.0 or more, preferably 2.3 or more, more preferably 2.5 or more.

In contrast, when B/A is extremely large, asperities on the surface of the membrane become extremely large, and bubbles of the gas generated from the alkali chloride electrolysis accumulate in the window portion, which is a recess. When gas adsorbs the surface of the ion exchange membrane, permeation of cations is prevented to thereby lead to an increase in the electrolytic voltage. Accordingly, in the ion exchange membrane according to the present embodiment, B/A is 5.0 or less, preferably 4.5 or less, more preferably 4.0 or less.

[0018]

[Average cross-sectional thickness of membrane C1]

The average cross-sectional thickness of membrane C1 is calculated as follows.

The position represented by " Δ " in Figure 4 corresponds to a region, in which strands of the reinforcement yarn constituting a strengthening material overlap with each other, and thickness c1 is measured at this position. The thickness c1, as shown in Figure 9 or

- 20 -

Figure 10, corresponds to a distance from the interface between the reinforcement yarn most distant from the surface of the layer S and the ion exchange resin to the surface of the layer S, the distance being measured in pure water and in the cross-sectional direction of the membrane. When a raised portion is formed on the surface of the layer S and formed only of an ion exchange resin which constitutes the ion exchange membrane, the distance from the surface of the layer C to the base of the raised portion is taken as the thickness c_1 . An example shown in Figure 10 corresponds to a case, in which raised portions formed of an ion exchange resin constituting the ion exchange membrane and a strengthening material exist on the surface of the layer S, and the distance from the surface of the layer C to the tip of a raised portion is taken as the thickness b .

As for a method for measuring the thickness c_1 , a slice having a width of about 100 μm may be cut off from a cross section of a target portion of an ion exchange membrane immersed in pure water in advance, by means of a razor or the like, subsequently the slice may be immersed in pure water with its cross section facing upward, and then the thickness of the slice may be measured using a microscope or the like. Alternatively, a tomographic image of a target portion of an ion exchange membrane immersed in pure water observed using MRI or the like may be used to measure the thickness.

- 21 -

The thickness c_1 was measured 15 points, and the thickness of the portion having the largest thickness is taken as c_1 (max).

c_1 (max) is determined at three different positions, and the average value thereof is the thickness C_1 .

Cations permeating the ion exchange membrane in the alkali chloride electrolysis have a property of preferentially permeating a window portion of the ion exchange membrane having a smaller thickness. When the thickness A is equivalent to or smaller than the thickness C_1 , cations tend to permeate the ion exchange membrane with no influence of a shadow portion, which is to be formed behind the reinforcement yarn to limit ion permeation. From the viewpoint of further reducing the electrolytic voltage in this manner, the thickness A is preferably equivalent to or smaller than the thickness C_1 in the first ion exchange membrane. In the second ion exchange membrane, the thickness A is equivalent to or smaller than the thickness C_1 .

That is, in the first ion exchange membrane, A and C_1 preferably satisfy formula (3):

$$40 \mu\text{m} \leq A \leq C_1 \dots (3)$$

wherein C_1 represents the maximum value of the distance between the surface of the layer S and a reinforcing yarn most distant from the surface of the layer S , the distance being measured in pure water and in the direction of the thickness of the membrane in a

region, in which strands of the reinforcement yarn overlap with each other.

In the second ion exchange membrane, A and C1 described above satisfy the above formula (3).

The thickness C1 can satisfy the aforementioned relation, for example, by setting the yarn diameter of the strengthening material within an appropriate range described below.

[0019]

[Average cross-sectional thickness of membrane C2]

The average cross-sectional thickness of membrane C2 is calculated as follows.

A position represented by " Δ " in Figure 4 corresponds to a region, in which strands of the reinforcement yarn constituting a strengthening material overlap with each other, and corresponds to a position at which thickness c2 is measured. The thickness c2, as shown in Figure 9 or Figure 10, corresponds to a distance in this region from the interface between the reinforcement yarn most distant from the surface of the layer S and the ion exchange resin to the interface between the reinforcement yarn nearest from the surface of the layer S and the ion exchange resin, in the cross-sectional direction of the membrane.

As for a method for measuring the thickness c2, a slice having a width of about 100 μm may be cut off from a cross section of a target portion of an ion exchange

membrane immersed in pure water in advance, by means of a razor or the like, subsequently the slice may be immersed in pure water with its cross section facing upward, and then the thickness of the slice may be measured using a microscope or the like. Alternatively, a tomographic image of a target portion of an ion exchange membrane immersed in pure water observed using MRI or the like may be used to measure the thickness.

The thickness c_2 was measured 15 points, and the thickness of the portion having the largest thickness is taken as c_2 (max).

c_2 (max) is determined at three different positions, and the average value thereof is the thickness C_2 .

In the ion exchange membrane according to the present embodiment, the thickness A is preferably equivalent to or smaller than the thickness C_2 because an effect of reducing the thickness of the membrane due to continuous holes formed by sacrifice yarn is effectively exerted.

The thickness C_2 can satisfy the aforementioned relation, for example, by setting the yarn diameter of the strengthening material within an appropriate range described below or the like.

In the ion exchange membrane according to the present embodiment, C_2 is preferably 130 μm or less. C_2 within this range tends to enable the electrolytic voltage to be reduced by suppressing the influence of a

- 24 -

shadow portion, which is to be formed behind reinforcement yarn which no cation permeate to limit permeation of cations through the ion exchange membrane. From the similar viewpoint, in the ion exchange membrane according to the present embodiment, C2 is more preferably 100 μm or less.

[0020]

[Layer S]

In the ion exchange membrane according to the present embodiment, the layer S contains a fluorine-containing polymer A having a sulfonic acid group. The fluorine-containing polymer A having a sulfonic acid group, constituting the layer S, is not limited to the following, and can be produced by copolymerizing monomers in a first group and monomers in a second group or homopolymerizing monomers in the second group, for example.

[0021]

Examples of the monomer in the first group include, but not limited to, fluorinated vinyl compounds. As such fluorinated vinyl compounds, those represented by the following general formula (1) are preferred:

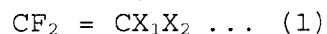

wherein X_1 and X_2 each independently represent F, Cl, H, or CF_3 .

[0022]

Examples of the fluorinated vinyl compound represented by the above general formula (1) include, but not limited to, vinyl fluoride, tetrafluoroethylene, hexafluoropropylene, vinylidene fluoride, trifluoroethylene, and chlorotrifluoroethylene.

[0023]

Particularly, when the ion exchange membrane according to the present embodiment is used as a membrane for alkali electrolysis, the fluorinated vinyl compound is preferably a perfluoro monomer, more preferably a perfluoro monomer selected from the group consisting of tetrafluoroethylene and hexafluoropropylene. Tetrafluoroethylene (TFE) is more preferred.

[0024]

Examples of the monomer in the second group include, but not limited to, vinyl compounds having functional groups that can be converted to sulfone-type ion exchange groups. As such vinyl compounds having functional groups that can be converted to sulfone-type ion exchange groups, those represented by the following general formula (2) are preferred:

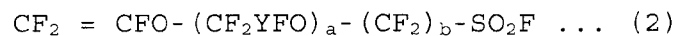

wherein a represents an integer of 0 to 2, b represents an integer of 1 to 4, Y represents F or CF_3 , and R represents CH_3 , C_2H_5 , or C_3H_7 .

[0025]

Specific examples thereof include the monomers shown below;

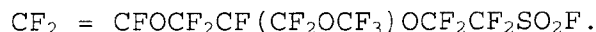
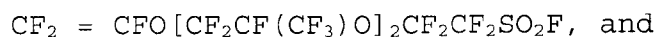
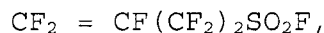
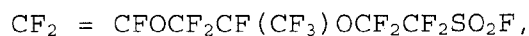

[0026]

Of these, $\text{CF}_2 = \text{CFOCF}_2\text{CF}(\text{CF}_3)\text{OCF}_2\text{CF}_2\text{CF}_2\text{SO}_2\text{F}$ and $\text{CF}_2 = \text{CFOCF}_2\text{CF}(\text{CF}_3)\text{OCF}_2\text{CF}_2\text{SO}_2\text{F}$ are more preferred.

The types of combination of the monomers constituting the polymer A, ratios, and degree of polymerization thereof are not particularly limited. The polymer A contained in the layer S may be a single polymer or a combination of two or more polymers. The ion exchange capacity of the fluorine-containing polymer A having a sulfonic acid group can be adjusted by changing the ratio between monomers represented by the above general formulas (1) and (2). More specifically, an example of adjustment includes copolymerization of monomers represented by the above general formula (1) and monomers represented by the above general formula (2) at 4:1 to 7:1.

[0027]

The layer S may be a single layer or may be a two-layer structure. When the layer S is a single layer, its thickness is preferably 50 to 180 μm , more preferably 70 to 160 μm , from the viewpoint of sufficiently achieving electrolysis performance and resistance to C damage on an electroconductive surface. When the layer S has a two-layer structure, a layer to be in contact with the anode is referred to as a layer S-1, a polymer forming the layer S-1 as a fluorine-containing polymer A-1, a layer to be in contact with the layer C as a layer S-2, and a polymer forming the layer S-2 as a fluorine-containing polymer A-2. The thickness of the layer S-1 is preferably 10 to 60 μm from the viewpoint of sufficiently achieving electrolysis performance and resistance to C damage on an electroconductive surface, and the thickness of the layer S-2 is preferably 30 to 120 μm , more preferably 40 to 100 μm , from the viewpoint of sufficiently achieving electrolysis performance and resistance to C damage on the electroconductive surface. From the viewpoint of retaining the strength of the membrane main body higher than a predetermined level, it is preferred to adjust the thickness of the layer S as mentioned above. The thickness of the layer S can be controlled to be in the range described above, for example, by employing preferable production conditions described below.

[0028]

[Layer C]

In the ion exchange membrane according to the present embodiment, the layer C contains a fluorine-containing polymer B having a carboxylic acid group. The fluorine-containing polymer having a carboxylic acid group, constituting the layer C, is not limited to the following and can be produced by copolymerizing monomers in the first group described above and monomers in a third group described below or by homopolymerizing monomers in the third group, for example.

[0029]

Examples of the monomer in the third group include, but not limited to, vinyl compounds having functional groups that can be converted to carboxylic acid-type ion exchange groups. As such vinyl compounds having functional groups that can be converted to carboxylic acid-type ion exchange groups, those represented by the following general formula (3) are preferred:

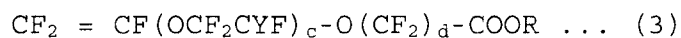

wherein c represents an integer of 0 to 2, d represents an integer of 1 to 4, Y represents F or CF₃, and R represents CH₃, C₂H₅, or C₃H₇.

[0030]

In the above general formula (3), it is preferred that Y be CF₃ and R be CH₃.

[0031]

Particularly, when the ion exchange membrane according to the present embodiment is used as an ion exchange membrane for alkali electrolysis, it is preferred to use at least perfluoro monomers as monomers in the third group. However, the alkyl group in the ester group (see the above R) is eliminated from the polymer on hydrolysis, and thus, the alkyl group (R) may not be a perfluoro alkyl group in which all the hydrogen atoms are replaced by fluorine atoms. Of these, monomers shown below are more preferred, for example:

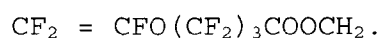
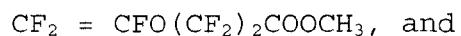
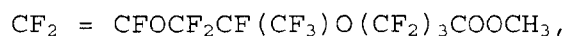
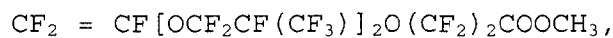
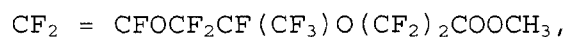
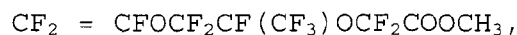

The monomers in the third group may be used singly or two or more of these may be used in combination. In the latter case, monomers other than those described above may be used in combination. Examples thereof include those represented by the general formula (2). The mixing form of the monomers are not particularly limited. A fluorine-containing copolymer obtained by copolymerizing monomers in the first group and monomers in the third group and a fluorine-containing copolymer obtained by copolymerizing monomers in the first group

- 30 -

and monomers not in the third group may be each simply mixed, or monomers in the first group, monomers in the third group, and monomers not in the third group may be copolymerized.

The types of combination of the monomers constituting the polymer B, ratios, and degree of polymerization thereof are not particularly limited. The polymer B contained in the layer C may be a single polymer or a combination of two or more polymers. The ion exchange capacity of the fluorine-containing polymer B having a carboxylic acid group can be adjusted by changing the ratio between monomers represented by the above general formulas (1) and (3). More specifically, an example of adjustment includes copolymerization of monomers represented by the above general formula (1) and monomers represented by the above general formula (3) at 6:1 to 9:1.

[0032]

In the ion exchange membrane according to the present embodiment, the thickness of the layer C is preferably 5 to 40 μm , more preferably 15 to 40 μm , still more preferably 15 to 30 μm , from the viewpoint of sufficiently achieving electrolysis performance and resistance to C damage on the electroconductive surface. The thickness of the layer C can be controlled to be in the range described above, for example, by employing preferable production conditions described below.

[0033]

From the aforementioned viewpoint, in the ion exchange membrane according to the present embodiment, the layer S contains a polymer of a compound represented by $\text{CF}_2 = \text{CF}-(\text{OCF}_2\text{YF})_a-\text{O}(\text{CF}_2)_b-\text{SO}_2\text{F}$, and the layer C contains a polymer of a compound represented by $\text{CF}_2 = \text{CF}-(\text{OCF}_2\text{CYF})_c-\text{O}(\text{CF}_2)_d-\text{COOR}$. In the formulas, it is preferred that a be an integer of 0 to 2, c be an integer of 0 to 2, b and d be an integer of 1 to 4, Y be F or CF_3 , and R be CH_3 , C_2H_5 , or C_3H_7 . Also, it is particularly preferred that the thickness of the layer S be 50 to 180 μm and the thickness of fluorine polymer layer C be 5 to 40 μm .

[0034]

As shown in Figure 1, in the ion exchange membrane according to the present embodiment, the membrane main body 10 at least includes a first layer having a sulfonic acid group as an ion exchange group (sulfonic acid layer: corresponding to the above layer S) 10a and a second layer having a carboxylic acid group as an ion exchange group laminated on the first layer 10a (carboxylic acid layer: corresponding to the above layer C) 10b. The ion exchange membrane 1 is usually arranged such that the first layer 10a, which is a sulfonic acid layer, is located on the anode side of the electrolyzer (see the arrow α) and the second layer 10b, which is a carboxylic acid layer, is located on the cathode side of the electrolyzer (see the arrow β). The first layer 10a is

preferably constituted of a material having low electrical resistance. The second layer 10b preferably has a high anion elimination property even if having a small membrane thickness. The anion elimination property referred to herein is a property of preventing infiltration and permeation of anion to the ion exchange membrane 1. The membrane thickness of the second layer 10b is preferably adjusted as mentioned above, from the viewpoint of reducing a reduction in the current efficiency and quality degradation of alkali hydroxide to be obtained and furthermore, allowing the resistance to damage on the cathode face to be especially satisfactory. When the membrane main body 10 has such a layer structure, the selective permeability of cations such as sodium ions tends to be further improved.

[0035]

(Raised portion)

As shown in Figure 1, a plurality of raised portions 11 is preferably formed on the surface of the layer S (10a). In the ion exchange membrane according to the present embodiment, raised portions are formed on the surface of the layer S (10a). It is preferred that the height be 20 μm or more and the arrangement density on the surface of the layer S (10a) be 20 to 1500 raised portions/ cm^2 , as viewed in a cross section. A raised portion referred to herein is a portion having a height of 20 μm or more from a reference point, which is a point

having the smallest height on the surface of the layer S (10a). The arrangement density of the raised portions per cm^2 of the surface of the ion exchange membrane 1 is preferably 20 to 1500/ cm^2 , more preferably 50 to 1200 raised portions/ cm^2 , from the viewpoint of sufficiently supplying a liquid electrolyte to the membrane.

Additionally, the total area of the raised portions is preferably 0.01 cm^2 to 0.6 cm^2 per cm^2 of the surface of the layer S from the viewpoint of increasing the amount of salt water to be supplied and reducing C damage on the electroconductive surface. The height and arrangement density of the raised portions can be controlled to be in the range described above, for example, by employing preferable production conditions described below. For the control described above, the production conditions described in Japanese Patent Nos. 4573715 and 4708133 can be employed.

[0036]

The height, shape, and arrangement density of the raised portions describe above each can be measured and checked by the following method. First, in an area of a 1000- μm square of the surface of the ion exchange membrane, a point having the smallest height is taken as the reference. Then, portions having a height of 20 μm or more from the reference point are taken as raised portions. The height is measured using a "Color 3D Laser Microscope (VK-9710)" manufactured by KEYENCE

- 34 -

CORPORATION. Specifically, a piece of 10 cm × 10 cm was optionally cut out from the ion exchange membrane in a dry state. The cathode side of the ion exchange membrane is fixed on a flat plate with double-sided tape, and the membrane is mounted on the measuring stage such that the anode side of the ion exchange membrane faces the measuring lens. The shape on the surface of the ion exchange membrane is measured in a 1000- μ m square measuring area of each 10 cm × 10 cm membrane. A point having the smallest height is taken as the reference, and the height from the reference is measured to thereby enable raised portions to be observed.

[0037]

The arrangement density of raised portions is a value obtained by cutting out three 10 cm × 10 cm pieces from the membrane, carrying out measuring at nine points across a 1000- μ m square measuring area of each 10 cm × 10 cm membrane, and averaging the measured values.

[0038]

The shape of the raised portions is not particularly limited, and the raised portions preferably have at least one shape selected from the group consisting of conical, polygonally pyramidal, truncated conical, truncated polygonally pyramidal, and hemispherical shapes. The hemispherical shape referred to herein also includes a shape called a centroclinal shape.

[0039]

(Opening and continuous hole)

In the ion exchange membrane according to the present embodiment, preferably, a plurality of opening portions 102 is formed on the surface of the layer S (10a), and continuous hole 104 for connecting the opening portions 102 with each other are formed inside the layer S (10a) (see Figure 2). The continuous holes 104 are holes that may serve as a flow path for cations generated on electrolysis and for a liquid electrolyte. Forming the continuous holes 104 inside the layer S (10a) can ensure the mobility of cations generated on electrolysis and a liquid electrolyte. The shape of the continuous holes 104 is not particularly limited, and the continuous holes 104 each may take an appropriate and suitable shape.

[0040]

Opening portions are formed on the surface of the membrane and continuous holes for connecting the opening portions with each other inside the membrane to thereby supply a liquid electrolyte inside the ion exchange membrane on electrolysis. Since this changes the concentration of impurities inside the membrane, the amount of impurities accumulated inside the membrane tends to decrease. When metal ions generated from elution of the cathode or impurities contained in a liquid electrolyte supplied to the cathode side of the

- 36 -

membrane infiltrate inside the membrane, the impurities become likely to be emitted from the membrane because opening portions are formed on the surface of the membrane. Thus, the amount of impurities accumulated tends to decrease. That is, the ion exchange membrane of the present embodiment, when having a configuration as described above, tends to have improved resistance against impurities existing in the liquid electrolyte on the anode side of the membrane and additionally against impurities generated on the cathode side of the membrane.

[0041]

When the alkali chloride aqueous solution is not sufficiently supplied, distinct damage is known to occur on the layer near the cathode of the membrane. The opening portions in the present embodiment can improve the supplying performance of the alkali chloride aqueous solution and reduce damage occurring on the cathode face of the membrane main body.

[0042]

The opening portions 102 formed on the surface of the layer S (10a) are a portion of the continuous hole 104 that is open on one surface of the membrane main body 10. Being open referred to herein means that the continuous hole is open outward from the surface of the layer S (10a). For example, when the surface of the layer S (10a) is coated with a coating layer described below, an open-hole area on which the continuous hole 104

are open outward on the surface of the layer S (10a) from which the coating layer has been removed is referred to as an opening.

[0043]

The opening portions 102 may be formed on the surface of the layer S (10a) and may be formed also on both the surfaces of the membrane main body 10 (that is, on the surface of the layer C (10b)). The arrangement interval and shape of the opening portions 102 on the surface of the layer S (10a) are not particularly limited, and appropriate and suitable conditions can be selected, in consideration of the shape and performance of the membrane main body 10 and operating conditions on electrolysis.

[0044]

The continuous holes 104 are preferably formed so as to alternately penetrate through the layer S (10a) side (the (α) side in Figure 1) and through the layer C (10b) side (the (β) side in Figure 1) of the reinforcement yarn 12. Such a structure enables the liquid electrolyte flowing in the space of the continuous holes 104 and cations (for example, sodium ions) contained in the electrolyte to be transferred between the anode side and the cathode side of the membrane main body 10. As a result, interruptions of the flow of cations in the ion exchange membrane 1 on electrolysis are reduced, and thus, there is a tendency to enable the electrical

resistance of the ion exchange membrane 1 to be further reduced.

[0045]

Specifically, as shown in Figure 1, as viewed in a cross section, the continuous holes 104 formed in the up-and-down direction in Figure 1 are preferably arranged alternately on the layer S (10a) side (the (α) side in Figure 1) and the layer C (10b) side (the (β) side in Figure 1) with respect to the reinforcement yarn 12 of which cross sections are shown, from the viewpoint of exerting more stable electrolytic performance and strength. Specifically, it is preferred that the continuous hole 104 be arranged on the layer S (10a) side of the reinforcement yarn 12 in a region A1 and the continuous holes 104 be arranged on the layer C (10b) side of the reinforcement yarn 12 in a region A4.

[0046]

The continuous holes 104, in Figure 2, are each formed along the up-and-down direction and the right-and-left direction of the paper. That is, the continuous holes 104 formed along the up-and-down direction of Figure 2 connect a plurality of opening portions 102 formed on the surface of the membrane main body 10 with each other in the up-and-down direction. The continuous holes 104 formed along the right-and-left direction of Figure 2 connect a plurality of opening portions 102 formed on the surface of the membrane main body 10 with

each other in the right-and-left direction. In the present embodiment, the continuous holes 104 may be formed along only one predetermined direction of the membrane main body 10 in this manner, but, from the viewpoint of exerting more stable electrolytic performance, the continuous holes 104 are preferably arranged both in the longitudinal direction and the lateral direction of the membrane main body 10.

[0047]

It is only required that continuous holes 104 connect at least two or more opening portions 102, and the positional relation between the opening portions 102 and the continuous holes 104 is not limited. One example of the opening portions 102 and continuous hole 104 is described herein using Figure 11, Figure 12, and Figure 13. Figure 11 is a partial enlarged view of a region A1 in Figure 1, Figure 12 is a partial enlarged view of a region A2 in Figure 1, and Figure 13 is a partial enlarged view of a region A3 in Figure 1. The regions A1 to A3 respectively shown in Figures 11 to 13 are regions where the opening portions 102 are provided in the ion exchange membrane 1.

[0048]

In the region A1 in Figure 11, a portion of the continuous hole 104 formed along the up-and-down direction of Figure 1 is open on the surface of the membrane main body 10 to thereby form the opening 102.

- 40 -

Behind the continuous hole 104, the reinforcement yarn 12 is arranged. The place where the opening 102 is provided is lined with the reinforcement yarn 12. This lining can prevent occurrence of a crack on the membrane starting from the opening when the membrane is bent, and thus, the mechanical strength of the ion exchange membrane 1 tends to be further improved.

[0049]

In the region A2 in Figure 12, a portion of the continuous hole 104 formed along the vertical direction to the paper of Figure 1 (i.e., the direction corresponding to the right-and-left direction in Figure 2) is exposed on the surface of the membrane main body 10 to thereby form the opening 102. Additionally, the continuous hole 104 formed along the vertical direction to the paper of Figure 1 crosses the continuous hole 104 formed along the up-and-down direction of Figure 1. As described above, when the continuous hole 104 is formed along two directions (e.g., the up-and-down direction and right-and-left direction in Figure 2, etc.), the opening 102 is preferably formed at the point where these continuous holes cross each other. This allows the liquid electrolyte to be supplied to both the continuous hole along the up-and-down direction and the continuous hole along right-and-left direction, and thus, the liquid electrolyte is likely to be supplied inside the entire ion exchange membrane. This changes the concentration of

- 41 -

impurities inside the membrane, and the amount of impurities accumulated inside the membrane tends to further decrease. When metal ions generated from elution of the cathode or impurities contained in a liquid electrolyte supplied to the cathode side of the membrane infiltrate inside the membrane, both impurities carried through the continuous hole 104 formed along the up-and-down direction and impurities carried through the continuous hole 104 formed along the right-and-left direction can be emitted through the opening 102. From such a viewpoint, the amount of impurities accumulated tends to decrease.

[0050]

In the region A3 in Figure 13, a portion of the continuous hole 104 formed along the up-and-down direction of Figure 1 is exposed on the surface of the membrane main body 10 to thereby form the opening 102. Additionally, the continuous hole 104 formed along the up-and-down direction to the paper of Figure 1 crosses the continuous hole 104 formed along the vertical direction to the paper of Figure 1 (i.e., the direction corresponding to the right-and-left direction in Figure 2). Also in the region A3, similarly to the region A2, the liquid electrolyte is supplied to both the continuous hole along the up-and-down direction and the continuous hole along right-and-left direction, and thus, the liquid electrolyte is likely to be supplied inside the entire

- 42 -

ion exchange membrane. This changes the concentration of impurities inside the membrane, and the amount of impurities accumulated inside the membrane tends to further decrease. When metal ions generated from elution of the cathode or impurities contained in a liquid electrolyte supplied to the cathode side of the membrane infiltrate inside the membrane, both impurities carried through the continuous hole 104 formed along the up-and-down direction and impurities carried through the continuous hole 104 formed along the right-and-left direction can be emitted through the opening 102. From such a viewpoint, the amount of impurities accumulated tends to decrease.

[0051]

(Strengthening material)

The ion exchange membrane according to the present embodiment has a strengthening material arranged inside the layer S (10a). In the present embodiment, the strengthening material is constituted of reinforcement yarn and sacrifice yarn. Examples thereof include, but not limited to, fabric formed by weaving reinforcement yarn and sacrifice yarn. The reinforcement yarn, which can stably exist inside the ion exchange membrane 1 by embedding the strengthening material in the membrane, imparts desired mechanical strength and dimension stability to the ion exchange membrane. The sacrifice yarn is eluted in a step (5) described below to thereby

form a continuous hole. The amount of the sacrifice yarn mix-woven is 10 to 80% by mass, more preferably 30 to 70% by mass based on the total strengthening material. The sacrifice yarn may be in a monofilament or multifilament form, preferably in a multifilament form. The sacrifice yarn preferably has a thickness of 20 to 50 deniers. The sacrifice yarn may be made of any raw material that is dissolved in the step (5) described below, and is preferably made of polyester such as polyethylene terephthalate (PET).

In the present embodiment, disposing the reinforcement yarn 12 inside the layer S (10a) particularly enables the ion exchange membrane 1 to expand and contract within a desired range. Such an ion exchange membrane 1 does not expand and contract more than required on electrolysis and the like and can maintain excellent dimension stability for a long period.

[0052]

The configuration of the reinforcement yarn 12 in the present embodiment is not particularly limited, and yarn formed by spinning reinforcement yarn can be used. Use of such yarn formed by spinning reinforcement yarn can impart further excellent dimension stability and mechanical strength to the ion exchange membrane 1.

[0053]

The materials of the reinforcement yarn are not particularly limited and are preferably materials

resistant to acid and alkali. From the viewpoint of imparting long-term heat resistance and chemical resistance, those containing a fluorine-containing polymer are preferred. Examples of the fluorine-containing polymer include, but not limited to, polytetrafluoroethylene (PTFE), tetrafluoroethylene-perfluoro alkyl vinyl ether copolymers (PFA), tetrafluoroethylene-ethylene copolymers (ETFE), tetrafluoroethylene-hexafluoropropylene copolymers, trifluorochlorethylene-ethylene copolymers, and vinylidene fluoride polymers (PVDF). Of these, polytetrafluoroethylene (PTFE) is preferred, from the viewpoint of heat resistance and chemical resistance.

[0054]

The yarn diameter of the reinforcement yarn is not particularly limited and is preferably 20 to 150 deniers, more preferably 50 to 120 deniers. The weaving density (number of strands of yarn inserted per unit length) of the reinforcement yarn is not particularly limited and preferably 5 to 50 strands/inch. The form of the reinforcement yarn is not particularly limited, and woven fabric, non-woven fabric, knitted fabric or the like is used, for example. Of these, it is preferred that the form be woven fabric. The thickness of the woven fabric is not particularly limited and is preferably 30 to 150 μm , more preferably 30 to 100 μm .

[0055]

In the present embodiment, the reinforcement yarn 12 may be monofilament or multifilament. Additionally, such yarn, slit yarn or the like is preferably used.

[0056]

The weaving method and arrangement for the reinforcement yarn 12 in the layer S (10a) are not particularly limited. An appropriately and suitably arrangement can be employed in consideration of the size and shape of the ion exchange membrane 1, physical properties required for the ion exchange membrane 1, an environment of usage and the like. For example, the reinforcement yarn 12 may be arranged along a predetermined direction of the layer S (10a). From the viewpoint of the dimension stability, it is preferred that a strand of the reinforcement yarn 12 be arranged along a predetermined first direction and another strand of the reinforcement yarn 12 be arranged along a second direction substantially perpendicular to the first direction (see Figure 3). A plurality of strands of the reinforcement yarn is arranged inside the longitudinal-direction layer S (10a) of the membrane main body so as to substantially directly run. This tends to impart further excellent dimension stability and mechanical strength in many directions. For example, an arrangement is preferred in which the reinforcement yarn 12 arranged along the longitudinal direction (warps) is interwoven

with the reinforcement yarn 12 arranged along the lateral direction (wefts) on the surface of layer S (10a). The arrangement is more preferably in the form of plain weave woven by allowing warps and wefts to run over and under each other alternately, leno weave in which two warps are woven into wefts while twisted, basket weave woven by inserting, into two or more parallelly-arranged warps, wefts of the same number, or the like, from the viewpoint of dimension stability and mechanical strength.

[0057]

Particularly, the reinforcement yarn 12 is preferably arranged along both the machine direction (MD) and the transverse direction (TD) of the ion exchange membrane 1. That is, the reinforcement yarn 12 is preferably plain-woven in the MD and the TD. The MD herein refers to the direction in which the membrane main body 10 and strengthening material are carried (flow direction) in the production step of ion exchange membrane described below, and the TD refers to the direction substantially perpendicular to the MD. Yarn woven along the MD is referred to as MD yarn, and yarn woven along the TD is referred to as TD yarn. The ion exchange membrane 1 used in electrolysis is usually rectangular. Thus, frequently, its longitudinal direction is the MD, and the width direction is the TD. By interweaving the reinforcement yarn 12 which is MD yarn into the reinforcement yarn 12 which is TD yarn

- 47 -

further excellent dimension stability and mechanical strength tend to be imparted in many directions.

[0058]

The arrangement interval for the reinforcement yarn 12 is not particularly limited. The reinforcement yarn can be appropriately and suitably arranged in consideration of physical properties required for the ion exchange membrane 1, an environment of usage and the like.

[0059]

(Aperture ratio)

In the ion exchange membrane according to the present embodiment, the aperture ratio of the reinforcement yarn 12 is not particularly limited and is preferably 30% or more, more preferably 50% or more and 90% or less. The aperture ratio is preferably 30% or more from the viewpoint of the electrochemical properties of the ion exchange membrane 1 and preferably 90% or less from the viewpoint of the mechanical strength of the ion exchange membrane 1.

[0060]

The aperture ratio referred to herein is a ratio of a total area of a surface through which substances such as ions (a liquid electrolyte and cations contained therein (e.g., sodium ions)) can pass (B) to the projected area of either one surface of the membrane main body 10 (A) (B/A). The total area of a surface through

which substances such as ions can pass (B) can be the sum of the projected area of the region in the ion exchange membrane 1 in which the cations, liquid electrolyte, and the like are not interrupted by the reinforcement yarn 12 included in the ion exchange membrane 1 or the like.

[0061]

Figure 14 illustrates a conceptual view for illustrating the aperture ratio of the ion exchange membrane according to the present embodiment. Figure 14, in which a portion of the ion exchange membrane 1 is enlarged, shows only the arrangement of the reinforcement yarn 12 in the regions, omitting illustration of the other members. Then, subtraction of the total projected area of the reinforcement yarn 12 (C) from the projected area of the ion exchange membrane including the reinforcement yarn 12 arranged along the longitudinal direction and the reinforcement yarn 12 arranged along the lateral direction (A) can determine the total area of the region through which substances such as ion can pass (B) in the area of the region described above (A). That is, the aperture ratio can be determined by the following formula (I):

$$\text{Aperture ratio} = (B)/(A) = ((A) - (C))/(A) \quad (I).$$

[0062]

Of these forms of reinforcement yarn 12, particularly preferred forms are preferably tape yarn and highly-oriented monofilaments containing PTFE from the

viewpoint of heat resistance and chemical resistance. Specifically, the reinforcement yarn is more preferably formed by plain-weaving using 50 to 300 deniers of tape yarn obtained by slitting a high-strength porous sheet made of PTFE into a tape form or a highly-oriented monofilament made of PTFE at a weaving density of 10 to 50 strands/inch, having a thickness in the range of 50 to 100 μm . The aperture ratio of the ion exchange membrane including such reinforcement yarn is preferably 60% or more.

[0063]

The shape of the reinforcement yarn is not particularly limited, and examples thereof include round yarn and tape yarn. These shapes are not particularly limited.

[0064]

(Opening area ratio)

The ion exchange membrane according to the present embodiment 1 preferably has a proportion of the total area of the opening portions 102 based on the area of the surface of the layer S (10a) on which the opening portions 102 are formed (opening area ratio) of 0.4 to 15%. When the opening area ratio is limited to such a range, impurities in the liquid electrolyte have a minor influence on the electrolytic performance, and stable electrolytic performance can be exerted. When the opening area ratio is 0.4% or more, an increase in the

electrolytic voltage, a decrease in the current efficiency, and a decrease in the purity of the product to be obtained, which are caused by infiltration of impurities contained in the liquid electrolyte into the ion exchange membrane 1 and accumulation of the impurities inside the membrane main body 10, tend to be more reduced. When the opening area ratio of the present embodiment is 15% or less, a decrease in the strength of the membrane and exposure of the reinforcement yarn tend to be more reduced. That is, when the opening area ratio of the ion exchange membrane 1 according to the present embodiment is adjusted to be in the range described above, an emission flow from the continuous holes 104 via the opening portions 102 to outside the membrane can be facilitated even when impurities are accumulated inside the membrane main body 10. Thus, the impurities have a minor influence on the electrolytic performance, and stable electrolytic performance can be exerted for a long period.

[0065]

Particularly, in alkali chloride electrolysis, alkali chloride used as an anode liquid and alkali hydroxide used as a cathode liquid contain metal compounds, metal ions, and impurities such as organic substances. Thus, such impurities have a major influence on the electrolytic voltage and current efficiency in alkali chloride electrolysis. When the opening area

- 51 -

ratio of the ion exchange membrane 1 according to the present embodiment is adjusted to be in the range described above, however, the liquid electrolyte is likely to be supplied inside the ion exchange membrane on electrolysis. This changes the concentration of the impurities inside the membrane, and the amount of the impurities accumulated inside the membrane can be reduced. When metal ions generated from elution of the cathode or impurities contained in the liquid electrolyte supplied to the cathode side of the membrane infiltrate inside the membrane, the impurities described above are allowed to permeate via the opening portions 102 and the continuous holes 104 to outside the membrane main body 10 with no difficulty. For this reason, the influence of the impurities generated during alkali chloride electrolysis on the electrolytic performance can be reduced, and stable electrolytic performance can be maintained for a long period. Additionally, the concentration of the impurities (alkali chloride and the like) in alkali hydroxide, which is the product, also can be prevented from increasing. From the viewpoint of reducing the influence of the impurities on the electrolytic performance in the ion exchange membrane 1 according to the present embodiment and maintaining a constant strength of the membrane, the opening area ratio of the opening portions 102 is more preferably 0.5 to 10%, still more preferably 0.5 to 5%. The opening area

ratio described above can be checked by a method described in Examples and can be controlled to be in the range described above, for example, by employing preferable production conditions described below.

[0066]

In the present embodiment, the opening area ratio of opening portions is the ratio of the area of the opening portions to the projected area, when the ion exchange membrane is viewed from the top surface, on the surface of the ion exchange membrane.

[0067]

(Opening density)

In the ion exchange membrane 1 according to the present embodiment, the opening density of the opening portions 102 on the surface of the layer S (10a) is not particularly limited, and is preferably 10 to 1000 opening portions/cm², more preferably 20 to 800 opening portions/cm². The opening density referred to herein is the number of opening portions 102 formed on 1 cm² of the surface of the layer S (10a) on which the opening portions 102 are formed. It should be noted that 1 cm² of the surface of the layer S (10a) is the projected area when the layer S (10a) is viewed from the top surface. When the opening density of the opening 102 is 10 opening portions/cm² or more, the average area per opening 102 can be appropriately smaller, and thus can be sufficiently smaller than the size of a hole (pinhole)

from which a crack, which is a cause of a reduction in the strength of the ion exchange membrane 1, may occur. When the opening density of the opening portions 102 is 1000 opening portions/cm² or less, the average area per opening 102 has a size large enough to allow metal ions and cations contained in the liquid electrolyte to infiltrate the continuous holes 104, and thus, the ion exchange membrane 1 tends to supply metal ions and cations or to allow metal ions and cations to permeate more efficiently. The opening density described above can be controlled to be in the range described above, for example, by employing preferable production conditions described below.

[0068]

(Exposed area ratio)

Figure 15 illustrates a schematic cross-sectional view of a second aspect of the ion exchange membrane according to the present embodiment. In the present embodiment, as shown in the ion exchange membrane 2 in Figure 15, exposed portion A5, which is a portion of the reinforcement yarn 22 exposed, may be formed on the surface of the membrane main body 20 on which raised portions 21 and opening portions 202 are formed. In the present embodiment, the exposed portion is preferably smaller. That is, an exposed area ratio described below is preferably 5% or less, more preferably 3% or less, further preferably 1% or less. Most preferably, the

exposed area ratio is 0%, that is, no exposed portion is formed. The exposed portion A5 herein refers to a site at which the reinforcement yarn 22 is externally exposed from the surface of the membrane main body 20. For example, when the surface of the membrane main body 20 is coated with a coating layer described below, the exposed portion A5 refers to a region from which the reinforcement yarn 22 is externally exposed on the surface of the membrane main body 20 after the coating layer is removed. When the exposed area ratio is 5% or less, there is a tendency to reduce an increase in the electrolytic voltage and to more reduce an increase in the concentration of chloride ions in alkali hydroxide to be obtained. The exposed area ratio described above is calculated by the following formula, and can be controlled to be in the range described above, for example, by employing preferable production conditions described below:

$$\begin{aligned} \text{Exposed area ratio (\%)} = & \left(\frac{\text{Sum of projected area of} \right. \\ & \text{the exposed portions, which are portions of the} \\ & \text{reinforcement yarn exposed when the surface of the} \\ & \text{membrane main body is viewed from the top surface)} / \\ & \left. \text{(Projected area of the surface of the membrane main body)} \right) \\ & \times 100. \end{aligned}$$

[0069]

In the present embodiment, the reinforcement yarn 22 preferably contains a fluorine-containing polymer such as

- 55 -

polytetrafluoroethylene (PTFE). When the reinforcement yarn 22 constituted of a fluorine-containing polymer is exposed on the surface of the membrane main body 20, the surface of the exposed portion A5 may exhibit hydrophobicity. When electrolytically generated gas in a solution state and cations are adsorbed on the exposed portion, which is hydrophobic, membrane permeation of the cations may be inhibited. In such a case, the electrolytic voltage increases, and the concentration of chloride ions in alkali hydroxide to be obtained may also increase. In the present embodiment, setting the exposed area ratio to 5% or less enables the existence ratio of the hydrophobic exposed portion to be in an appropriate range, and the increase in the electrolytic voltage and the increase in chloride ions in alkali hydroxide described above tend to be effectively reduced.

[0070]

Furthermore, electrolytically generated gas in a solution state and impurities in the liquid electrolyte such as metal ions adsorb the exposed portions, infiltrate inside the membrane main body 20, and permeate the membrane, becoming impurities in sodium hydroxide. In the present embodiment, setting the exposed area ratio to 3% or less tends to more effectively reduce adsorption, infiltration, and permeation of the impurities, and thus, tends to enable more highly pure sodium hydroxide to be produced.

[0071]

Particularly, in the ion exchange membrane 2 according to the present embodiment, since the opening area ratio described above is 0.4 to 15% and the exposed area ratio described above is 5% or less, a decrease in the current efficiency due to impurities can be further reduced. In the case of alkali electrolysis, the concentration of the impurities in sodium hydroxide, which is a product, tends to be maintained lower. Furthermore, an increase in the electrolytic voltage is also reduced, and thus, there is a tendency to enable more stable electrolytic performance to be exerted.

[0072]

In the present embodiment, the exposed area ratio of the exposed portions is the sum of the projected area of the exposed portions formed on the reinforcement yarn based on the sum of the projected area of the reinforcement yarn, when viewed from the top surface. The exposed area ratio will be an index that indicates how much the reinforcement yarn included in the ion exchange membrane is exposed. Accordingly, the exposed area ratio of the exposed portions can be directly calculated by determining the projected area of the reinforcement yarn and the projected area of the exposed portions, and also can be calculated using the aperture ratio described above by the following formula (II). A more specific description now will be given with

- 57 -

reference to the drawings. Figure 16 illustrates a schematic view for illustrating the exposed area ratio of the ion exchange membrane 2 according to the present embodiment. Figure 16, in which a portion of the ion exchange membrane 2, as viewed from the top surface, is enlarged, only shows the arrangement of the reinforcement yarn 22, omitting illustration of the other members. In Figure 16, a plurality of exposed portions A5 is formed on the surface of the reinforcement yarn 22 arranged along the longitudinal direction and the reinforcement yarn 22 arranged along the lateral direction. Herein, the sum of the projected area of exposed portions A5, as viewed from the top surface, is taken as S1, and the sum of the projected area of the reinforcement yarn 22 is taken as S2. Then, the exposed area ratio is represented by $S1/S2$, and formula (II) can be derived using formula (I) described below.

The exposed area ratio is $S1/S2$.

Herein, on the basis of the above formula (I),

$S2 = C = A - B = A(1 - B/A) = A(1 - \text{Aperture ratio})$

is established, and thus, resulting in

$\text{Exposed area ratio} = S1/(A(1 - \text{aperture ratio}))$

(II).

wherein S1: sum of the projected area of the exposed portions A5,

S2: sum of the projected area of the reinforcement yarn 22,

- 58 -

A: projected area of the ion exchange membrane including the reinforcement yarn 22 arranged along the longitudinal direction and the reinforcement yarn 12 (22) arranged along the lateral direction (see Figure 14).

B: total area of the region through which substances such as ions can pass (B) (see Figure 14.) and

C: total area of the reinforcement yarn 22.

[0073]

As shown in Figure 15, the ion exchange membrane 2 according to the present embodiment includes a membrane main body 20 constituted of a layer S (20a) and a layer C (20b) and reinforcement yarn 22 inside the layer S (20a), and on the surface of the layer S (20a) on which opening portions 202 are formed, raised portions 21 having a height of 20 μm or more are formed, as viewed in a cross section. As described above, in the present embodiment, when the vertical direction with respect to the surface of the layer S (20a) is taken as the height direction (e.g., see the arrow α and the arrow β in Figure 15), the surface having opening portions 202 preferably has raised portions 21. The layer S (20a), which has the opening portions 202 and raised portions 21, allows the liquid electrolyte to be sufficiently supplied to the membrane main body 20 on electrolysis, and thus, the influence of impurities can be more reduced. Additionally, the opening portions 202, exposed portions, and raised portions 21 are more preferably formed on the surface of

the layer S (20a). Usually, the ion exchange membrane is used in close contact with the anode for the purpose of reducing the electrolytic voltage. However, when the ion exchange membrane comes in close contact with the anode, the liquid electrolyte (the anode liquid such as brine) becomes unlikely to be supplied. Then, since the raised portions have been formed on the surface of the ion exchange membrane, the close contact of the ion exchange membrane with the anode can be suppressed to thereby enable the liquid electrolyte to be smoothly supplied. As a result, metal ions or other impurities can be prevented from accumulating in the ion exchange membrane, the concentration of chloride ions in alkali hydroxide to be obtained is reduced, and then, damage of the cathode surface of the membrane can be reduced.

[0074]

(Coating layer)

The ion exchange membrane according to the present embodiment preferably further has a coating layer with which at least a portion of at least one surface of the membrane main body is coated, from the viewpoint of preventing adsorption of gas on the cathode side surface and the anode side surface on electrolysis. Figure 17 illustrates a schematic cross-sectional view of a third aspect of the ion exchange membrane according to the present embodiment. The ion exchange membrane 3 includes a membrane main body 30 constituted of a layer S (30a)

- 60 -

and a layer C (30b) and has reinforcement yarn 32 arranged inside the membrane main body 30. On the surface of layer S (30a) side (see the arrow α) of the membrane main body 30, a plurality of raised portions 31 is formed and a plurality of opening portions 302 is formed, and a continuous hole 304 for connecting at least two of the opening 302 with one another is formed inside the membrane main body 30. Additionally, the surface of the layer S (30a) (see the arrow α) is coated with a coating layer 34a, and the surface of the layer C (30b) (see the arrow β) is coated with a coating layer 34b. That is, the ion exchange membrane 3 is a membrane formed by coating the surfaces of the membrane main body of the ion exchange membrane 1 shown in Figure 1 with the coating layers. Coating each of the surfaces of the membrane main body 30 with the coating layers 34a or 34b can prevent gas generated on electrolysis from adsorbing the membrane surfaces. This can further improve the membrane permeability of the cations, and thus, the electrolytic voltage tends to be further reduced.

[0075]

The raised portions 31 and the opening portions 302 may or may not be completely coated with the coating layer 34a. That is, the raised portions 31 and the opening 302 may be visually observable from the surface of the coating layer 34a.

[0076]

The materials constituting the coating layers 34a and 34b are not particularly limited and preferably contain minerals from the viewpoint of prevention of gas adsorption. Examples of the mineral include, but not limited to, zirconium oxide and titanium oxide. As a method for forming the coating layers 34a and 34b on the surfaces of the membrane main body 30, known methods can be employed, without particular limitation. An example thereof is a method for applying a liquid prepared by dispersing fine particulates of inorganic oxide in a binder polymer solution by spraying or the like (spray method). Examples of the binder polymer include, but not limited to, vinyl compounds having functional groups that can be converted to sulfone-type ion exchange groups. The application conditions are not particularly limited, and spraying can be used at 60°C, for example. Examples of methods other than the spray method include, but not limited to, roll coating.

[0077]

The coating layer 34a is laminated on the surface of the layer S (30a). In the present embodiment, the opening portions 302 are only required to be open on the surface of the membrane main body 30 and do not have to necessarily be open on the surface of the coating layer.

[0078]

The coating layers 34a and 34b are only required to cover at least one surface of the membrane main body 30. Accordingly, for example, the coating layer 34a may be provided only on the surface of the layer S (30a), or the coating layer 34b may be provided only on the surface of the layer C (30b). In the present embodiment, each of the surfaces of the membrane main body 30 are preferably coated with the coating layers 34a or 34b from the viewpoint of prevention of gas adsorption.

[0079]

The coating layers 34a and 34b are only required to cover at least a portion of a surface of the membrane main body 30 and may not necessarily cover the surface entirely. However, from the viewpoint of prevention of gas adsorption, it is preferred that the surfaces of the membrane main body 30 be entirely coated with the coating layers 34a and 34b.

[0080]

The average thickness of the coating layers 34a and 34b is preferably 1 to 10 μm , from the viewpoint of prevention of gas adsorption and of an increase in the electrical resistance due to the thickness.

[0081]

The ion exchange membrane 3 is a membrane formed by coating each of the surfaces of the ion exchange membrane 1 shown in Figure 1 with the coating layer 34a and 34b.

As for the members and configuration other than the coating layers 34a and 34b, the members and configuration of the ion exchange membrane 1 already described can be employed.

[0082]

Figure 18 illustrates a schematic cross-sectional view of a fourth aspect of the ion exchange membrane according to the present embodiment. The ion exchange membrane 4 includes a membrane main body 40 constituted of a layer S (40a) and a layer C (40b) and reinforcement yarn 42 arranged inside the layer S (40a). On the surface of the layer S (40a) (see the arrow α), a plurality of raised portions 41 are formed and a plurality of opening portions 402 are formed, and a continuous hole 404 for connecting at least two of the opening portions 402 with one another is formed inside the membrane main body 40. An exposed portion A5, which is a portion of the reinforcement yarn 42 exposed, is formed on the surface of the membrane main body 40 on which the opening portions 402 are formed. Additionally, the surface of the layer S (40a) (see the arrow α) is coated with a coating layer 44a, and the surface of the layer C (40b) (see the arrow β) is coated with a coating layer 44b. That is, the ion exchange membrane 4 is a membrane formed by coating the surfaces of the membrane main body of the ion exchange membrane 2 shown in Figure 15 with the coating layers. Coating each of the surfaces

of the membrane main body 40 with the coating layers 44a and 44b can prevent gas generated on electrolysis from adsorbing the membrane surfaces. This can further improve the membrane permeability of the cations, and thus, the electrolytic voltage tends to be further reduced.

[0083]

At the exposed portion A5, the reinforcement yarn 42 is only required to be exposed on at least the surface of the layer S (40a) and is not required to be exposed on the surface of the coating layer 44a.

[0084]

The ion exchange membrane 4 is a membrane formed by coating each of the surfaces of ion exchange membrane 2 shown in Figure 15 with the coating layers 44a and 44b. As for the members and configuration other than the coating layers 44a and 44b, the members and configuration of the ion exchange membrane 2 already described can be employed. As for the coating layers 44a and 44b, the members and constitutions described as the coating layers 34a and 34b employed in the ion exchange membrane 3 shown in Figure 17 can be employed in the same manner.

[0085]

[Ion exchange capacity]

In the ion exchange membrane according to the present embodiment, the ion exchange capacity of the fluorine-containing polymer refers to the equivalent of

- 65 -

exchange groups per g of dry resin and can be determined by neutralization titration or infrared spectroscopic analysis. In the case of measurement by infrared spectroscopic analysis, the ion exchange capacity can be measured by a method described in Example described below. In the present embodiment, a value obtained by measuring a fluorine-containing polymer to be used (before hydrolysis treatment) by infrared spectroscopic analysis may be used as the ion exchange capacity, or a value obtained by measurement by neutralization titration after hydrolysis may be used as the ion exchange capacity. The ion exchange capacity of the layer S is preferably 1.43 to 0.98 meq/g, more preferably 1.10 to 0.98 meq/g. The ion exchange capacity of the layer C is 1.10 to 0.80 meq/g, preferably 1.00 to 0.80 meq/g, more preferably 0.98 to 0.83 meq/g. In the present embodiment, when the layer S and/or layer C are/is constituted of a plurality of layers, each of the layers preferably satisfies the aforementioned ion exchange capacity.

[0086]

[Electrolyzer]

The ion exchange membrane according to the present embodiment can be used in various electrolyzers. That is, the electrolyzer of the present embodiment includes an ion exchange membrane according to the present embodiment. As illustrated in Figure 20, an electrolyzer

13 includes at least an anode 11, a cathode 12, and an ion exchange membrane according to the present embodiment arranged between the anode and the cathode. The electrolyzer can be used for various types of electrolysis, and as a typical example, a case when the electrolyzer is used for electrolysis of an alkali chloride aqueous solution will be described below.

[0087]

Electrolysis conditions are not particularly limited, and the electrolysis can be carried out under known conditions. For example, with the anode chamber provided with 2.5 to 5.5 N alkali chloride aqueous solution and the cathode chamber provided with water or diluted alkali hydroxide aqueous solution, electrolysis can be carried out under conditions including an electrolysis temperature of 50 to 120°C and a current density of 5 to 100 A/dm².

[0088]

The configuration of the electrolyzer according to the present embodiment is not particularly limited and may be monopolar or bipolar, for example. Materials constituting the electrolyzer are not particularly limited. As materials for the anode chamber, titanium and the like, which are resistant to alkali chloride and chlorine, are preferred. As materials for the cathode chamber, nickel and the like, which are resistant to alkali hydroxide and hydrogen, are preferred. As for the

arrangement of the electrodes, even when the ion exchange membrane and the anode are arranged with an appropriate gap therebetween or even when the anode is arranged in contact with the ion exchange membrane, the ion exchange membrane can be used without any problem. In a contact electrolyzer (zero-gap base electrolyzer), in which no gap is provided between the ion exchange membrane and the anode and between the ion exchange membrane and the cathode, the ion exchange membrane of the present embodiment achieves a greater effect.

[0089]

[Method for producing ion exchange membrane]

A suitable example of a method for producing an ion exchange membrane according to the present embodiment includes a method including the following steps (1) to (6):

- (1) a step of producing a fluorine-containing polymer having ion exchange groups or ion exchange group precursors, which may become ion exchange groups by hydrolysis;
- (2) a step of obtaining a strengthening material in which sacrifice yarn, which is soluble in acid or alkali and forms continuous holes, is arranged between adjacent strands of reinforcement yarn by interweaving at least a plurality of strands of the reinforcement yarn and the sacrifice yarn;

- 68 -

- (3) a step of forming a film from the fluorine-containing polymer having ion exchange groups or ion exchange group precursors, which may become ion exchange groups by hydrolysis, to obtain a film;
- (4) a step of embedding the strengthening material in the film to obtain a membrane main body including the strengthening material arranged therein;
- (5) a step of hydrolyzing the ion exchange group precursors of the fluorine polymer with acid or alkali to obtain ion exchange groups and to dissolve the sacrifice yarn to thereby form continuous holes inside the membrane main body (hydrolysis step), and
- (6) a step of forming the opening portions on the membrane surface of the membrane main body by polishing the membrane surface.

[0090]

According to the method described above, in the step (4) of embedding, the membrane main body having desired raised portions formed can be obtained by controlling treatment conditions such as temperature, pressure, and time during embedding. Then, in the step (5), dissolution of the sacrifice yarn arranged inside the membrane main body enables continuous holes to be formed inside the membrane main body and, in the step (6), opening portions to be formed on the membrane surface. This enables the ion exchange membrane to be obtained.

Hereinafter, each of the steps will be described in more detail.

[0091]

Step (1): Production of fluorine-containing polymer

In the present embodiment, a fluorine-containing polymer having ion exchange groups or ion exchange group precursors, which may become ion exchange groups by hydrolysis, can be obtained by appropriately polymerizing the above monomers as mentioned above. In order to control the ion exchange capacity of the fluorine-containing polymer, it is only required that the mixture ratio of the raw material monomers and the like be adjusted in the production step as mentioned above.

[0092]

Step (2): Step of obtaining strengthening material

In the step (2), adjustment of the shape and arrangement of the reinforcement yarn, sacrifice yarn and the like can control the opening area ratio, exposed area ratio, opening density, continuous hole arrangement and the like. For example, when the sacrifice yarn is made thicker, the sacrifice yarn is likely to be located near the surface of the membrane main body in the step (4) described below. The sacrifice yarn is dissolved in the step (5) described below, and opening portions are likely to be formed by polishing the surface in the step (6).

Controlling the number of strands of the sacrifice yarn also can control the opening density. Likewise,

- 70 -

when the reinforcement yarn is made thicker, the reinforcement yarn is likely to protrude outward from the surface of the membrane main body in the step (6) describe below, and thus, exposed portions are likely to be formed.

Furthermore, the aforementioned aperture ratio of the reinforcement yarn can be controlled by adjusting the thickness of the reinforcement yarn and mesh, for example. That is, thicker reinforcement yarn tends to reduce the aperture ratio, and thinner reinforcement yarn tends to increase the aperture ratio. An increase of the mesh tends to reduce the aperture ratio, and less mesh tends to increase the aperture ratio. From the viewpoint of further increasing the electrolytic performance, the aperture ratio is preferably increased as described above, and from the viewpoint of achieving strength, the aperture ratio is preferably reduced.

[0093]

Step (3): Step of film formation

In the step (3), a film is formed from the fluorine-containing polymer obtained in the step (1) by use of an extruder. The film may have a two-layer structure of a sulfonic acid layer and a carboxylic acid layer or may have a multilayer structure of three or more layers as described above. The method for forming a film is not particularly limited, and examples thereof include the following:

- 71 -

- a method in which films are formed separately from fluorine-containing polymers each constituting the layers, and

- a method in which fluorine-containing polymers constituting both the carboxylic acid layer and the sulfonic acid layer are coextruded to form a composite film, and a fluorine-containing polymer constituting another sulfonic acid layer is separately used to form a film.

Coextrusion is preferred because of its contribution to an increase in the adhesive strength in the interface.

[0094]

Step (4): Step of obtaining membrane main body

In the step (4), the strengthening material obtained in the step (2) is embedded in the film obtained in the step (3) to obtain a membrane main body including the strengthening material therein.

The embedding method is not limited, and an example thereof is a method in which the strengthening material and the film are laminated in the order mentioned on breathable heat-resistant release paper on a flat plate or drum including a heat source and/or a vacuum source therein and having many pores on the surface thereof and integrated at a temperature at which the fluorine-containing polymer of the film melts while the air among each of the layers was evacuated by reduced pressure.

[0095]

Examples of the embedding method in the case of a three-layer structure of two sulfonic acid layers and a carboxylic acid layer include, but not limited to, a method in which release paper, a film constituting a sulfonic acid layer, a strengthening material, a film constituting a sulfonic acid layer, and a film constituting a carboxylic acid layer are laminated in the order mentioned on a drum and integrated, and a method in which release paper, a film constituting a sulfonic acid layer, a strengthening material, and a composite film in which a sulfonic acid layer faces the strengthening material side are laminated in the order mentioned and integrated.

[0096]

An example of the embedding method in the case of a composite membrane having a multilayer structure of three or more layers includes, but not limited to, a method in which release paper, a plurality of films each constituting each of the layers, a strengthening material, and a plurality of films each constituting each of the layers are laminated in the order mentioned on a drum and integrated. In the case of a multilayer structure of three or more layers, adjustment is preferably carried out such that the film constituting the carboxylic acid layer is laminated at the farthest position from the drum and the film constituting the

sulfonic acid layer is laminated at a position near the drum.

[0097]

The method including integration under a reduced pressure tends to make the third layer on the strengthening material thicker than that of a pressure-application press method. A variety of laminations described herein is exemplary. After an appropriate and suitable lamination pattern (for example, combination of each of layers) is selected in consideration of the layer configuration and physical properties of a desired membrane main body, coextrusion can be carried out.

[0098]

For the purpose of further improving the electric properties of the ion exchange membrane according to the present embodiment, it is also possible to additionally interpose a layer containing both carboxylate functional groups and sulfonyl fluoride functional groups between the sulfonic acid layer and the carboxylic acid layer describe above or to use a layer containing both carboxylate functional groups and sulfonyl fluoride functional groups.

Examples of the method for producing a fluorine-containing polymer that forms this layer may include a method in which a polymer containing carboxylate functional groups and a polymer containing sulfonyl

fluoride functional groups are separately produced and then mixed and a method in which both monomers containing carboxylate functional groups and monomers containing sulfonyl fluoride functional groups are copolymerized.

[0099]

Step (5): Step of hydrolyzing

In the step (5), the sacrifice yarn included in the membrane main body is removed by dissolution in acid or alkali to form continuous holes in the membrane main body. The sacrifice yarn has solubility in acid or alkali in the step of producing an ion exchange membrane or under an electrolysis environment. Thus, dissolution of the sacrifice yarn in acid or alkali from the membrane main body allows continuous holes to be formed at corresponding sites. The ion exchange membrane including continuous holes formed in the membrane main body can be obtained in this manner. The sacrifice yarn may remain in the continuous holes, not completely dissolved and removed. The sacrifice yarn remaining in the continuous holes may be dissolved and removed by the liquid electrolyte when electrolysis is carried out.

[0100]

The acid or alkali used in the step (5) is only required to dissolve the sacrifice yarn, and the types thereof are not particularly limited. Examples of the acid include, but not limited to, hydrochloric acid, nitric acid, sulfuric acid, acetic acid, and fluorine-

- 75 -

containing acetic acid. Examples of the alkali include, but not limited to, potassium hydroxide and sodium hydroxide.

[0101]

The step of forming continuous holes by eluting the sacrifice yarn will be now described in more detail. Figure 19 illustrates a schematic view for illustrating a method for forming continuous holes of the ion exchange membrane according to the present embodiment. Figure 19 shows reinforcement yarn 52 and sacrifice yarn 504a (continuous holes 504 to be formed thereby) only, omitting illustration of the other members such as a membrane main body. First, the reinforcement yarn 52 and the sacrifice yarn 504a are interwoven to form a strengthening material 5. Then, in the step (5), the sacrifice yarn 504a is eluted to form the continuous holes 504.

If the sacrifice yarn is entirely dissolved in the step (5), as described in Japanese Patent No. 5844653, in the case where the ion exchange membrane is mounted in an electrolyzer and an alkali chloride aqueous solution is poured into the electrolyzer, the alkali chloride aqueous solution may leak out of the cell through the dissolution holes. Thus, it is preferred to leave the 30 to 80% of the yarn diameter of the sacrifice yarn.

[0102]

The method described above is simple because interweaving of the reinforcement yarn 52 and sacrifice yarn 504a may be adjusted depending on the arrangement of the reinforcement yarn 52, continuous holes 504, and opening portions (not shown) inside the membrane main body of the ion exchange membrane. Figure 19 exemplifies the plain-woven strengthening material 5 in which the reinforcement yarn 52 and sacrifice yarn 504a are interwoven along both the longitudinal direction and the lateral direction in the paper, and the arrangement of the reinforcement yarn 52 and the sacrifice yarn 504a in the strengthening material 5 may be varied as required.

In the step (5), it is also possible to introduce ion exchange groups into ion exchange group precursors by hydrolyzing the obtained membrane main body obtained in the step (4).

[0103]

In the method including exposing the sacrifice core material and reinforcement yarn on the surface of the ion exchange membrane by polishing in the step (6), only the polymer on the continuous holes having poor abrasion resistance is selectively removed. Thus, opening portions can be efficiently formed without considerably increasing the exposed area ratio of the reinforcement yarn. The method for producing an ion exchange membrane according to the present embodiment can increase the

opening area ratio of the opening portions as well as reduce the exposed area ratio of the exposed portions. An example of the polishing method include, but not limited to, a method including bringing a polishing roller in contact with a running membrane and rotating the polishing roller at a speed higher than the running speed of the membrane or in a direction opposite to the running direction of the membrane. In this case, a larger relative speed between the polishing roller and the membrane, a larger embracing angle of the polishing roller, and a larger running tension of the polishing roller lead to a higher opening area ratio of the opening portions, but also leads to a higher exposed area ratio of the exposed portion. Thus, the relative speed between the polishing roller and the membrane is preferably 50 m/h to 1000 m/h.

[0104]

In the ion exchange membrane according to the present embodiment, as a method for forming raised portions on the surface of the membrane main body, which is not particularly limited, a known method also can be employed including forming raised portions on a resin surface. In the present embodiment, an example of the method for forming raised portions on the surface of the membrane main body specifically includes a method including subjecting the surface of the membrane main body to embossing. For example, when the film,

- 78 -

strengthening material and the like are integrated, the raised portions described above can be formed using embossed release paper embossed in advance.

[0105]

According to the method of producing an ion exchange membrane according to the present embodiment, opening portions and exposed portions are formed by polishing the membrane in a wet state after hydrolysis. Additionally, the polymer in the membrane main body has sufficient flexibility. Thus, the shape of the raised portion would not be changed. In the case where raised portions are formed by embossing, the height and arrangement density of the raised portions can be controlled by controlling the emboss shape to be transferred (shape of the release paper).

[0106]

After the aforementioned steps (1) to (6) are accomplished, the aforementioned coating layers may be formed on the surfaces of the ion exchange membrane obtained.

Examples

[0107]

Hereinafter, the present embodiment will be described in detail by means of examples. The present embodiment is not intended to be limited to the following examples.

- 79 -

[0108]

[Method for measuring average cross-sectional thickness of membrane A]

The ion exchange membrane after the hydrolysis step was cut in the vertical direction from the layer C side or the layer S side to the surface of the layer to obtain a sample having a longer side of 6 mm or more and a shorter side of about 100 μm . At this time, as shown in Figure 4, the sides of the sample were allowed to be parallel to four strands of the reinforcement yarn. The thickness of the sample in a water-containing state was measured using an optical microscope with a cross section facing upward. In this case, a portion to be cut off included two or more adjacent strands of the reinforcement yarn, two or more adjacent continuous holes (derived from the sacrifice yarn), and the center portion of the region surround by the strands of the reinforcement yarn and the continuous holes, which is a portion indicated by "○" in Figure 4. A piece to be cut off included six or more strands of the reinforcement yarn perpendicular to the cutting direction. Such a piece was sampled at three positions. From the cross-sectional view of each of the pieces obtained, a was measured as shown in Figures 5 to 6 to calculate a (min) for each piece. From a (min) at three positions, the average cross-sectional thickness of membrane A was calculated.

- 80 -

[0109]

[Method for measuring average cross-sectional thicknesses of membrane B, C1, and C2]

The ion exchange membrane after the hydrolysis step was cut in the vertical direction from the layer C side or the layer S side to the surface of the layer to obtain a sample having a longer side of 6 mm or more and a shorter side of about 100 μm . At this time, as shown in Figure 4, the sides of the sample were allowed to be parallel to four strands of the reinforcement yarn. The thickness of the sample in a water-containing state was measured using an optical microscope with a cross section facing upward. In this case, a portion to be cut off was the center portion of the reinforcement yarn, which included portions indicated by \square or \triangle in Figure 4. A piece to be cut off included 15 or more strands of the reinforcement yarn perpendicular to the cutting direction. Such a piece was sampled at three positions. From the cross-sectional view of each of the pieces obtained, b, c1, and c2 were measured as shown in Figures 7 to 10 to calculate each of b (max), c1 (max), and c2 (max). From b (max), c1(max), and c2 (max) at three positions, the average cross-sectional thicknesses of membrane B, C1, and C2 were calculated.

- 81 -

[0110]

[Measurement of membrane strength]

The strength of the membrane in Examples and Comparative Examples, which was breaking strength obtained by tensile testing, was measured by the following method. Along the direction at an angle of 45 degrees with respect to the reinforcement yarn embedded in the ion exchange membrane, a sample having a width of 1 cm was cut from the ion exchange membrane immersed in pure water. Then, the breaking elongation of the sample was measured under conditions including a distance between chucks of 5 cm and a tensile speed of 100 mm/minute in compliance with JISK6732. The measurement sample was stored by immersion in pure water at 25°C until immediately before measurement, and was measured within three minutes after the sample was taken out of pure water. Seven samples from the same ion exchange membrane were measured, and the average value of the seven breaking elongation values was taken as the strength of the membrane.

[0111]

[Electrolytic voltage measurement]

The electrolyzer used for electrolysis was one in which four natural-circulation zero-gap electrolytic cells were arranged in series, each of which had a structure including an ion exchange membrane arranged between an anode and a cathode. As the cathode, woven

- 82 -

mesh was used formed by knitting nickel fine wire having a diameter of 0.15 mm and coated with cerium oxide and ruthenium oxide as catalysts in a sieve mesh size of 50. To bring the cathode into close contact with the ion exchange membrane, a mat formed by knitting nickel fine wire was arranged between a collector made of nickel expanded metal and the cathode. As the anode, used was titanium expanded metal coated with ruthenium oxide, iridium oxide, and titanium oxide as catalysts. By use of the electrolyzer described above, brine was supplied to the anode side while the concentration was adjusted to be 205 g/L, and water was supplied to the cathode side while the sodium hydroxide concentration was maintained at 32% by mass. Electrolysis was carried out with the temperature of the electrolyzer set to 85°C, at a current density of 6 kA/m² under a condition in which the liquid pressure of the cathode side of the electrolyzer was higher than the liquid pressure of the anode side by 5.3 kPa. The pair voltage between the anode and the cathode of the electrolyzer was measured every day by a voltmeter TR-V1000 manufactured by KEYENCE CORPORATION. The average value for seven days was determined as the electrolytic voltage.

[0112]

[Measurement of area ratio of opening portions]

A microscopic image of the surface of the ion exchange membrane was image analyzed to measure the area

ratio of opening portions. First, a piece having a size of 2 mm in length and 3 mm in width was cut out from the surface of the membrane main body of the ion exchange membrane after hydrolysis and used as a sample. The sample cut out was dyed by immersion in a liquid prepared by dissolving 0.1 g of Crystal violet as dye in a mixed solvent of 100 mL of water and 500 mL of ethanol. A microscope (manufactured by Olympus Corporation) was used to observe the surface state of the sample after dying at a magnification of 20×. Nine samples were cut out from the surface of one ion exchange membrane, and the average value thereof was used for evaluation (N = 9).

[0113]

A white region not dyed with the dye corresponds to an opening or an exposed portion of the reinforcement yarn. Whether the region corresponds to an opening or an exposed portion was determined by the positional relation between the reinforcement yarn and continuous holes in the ion exchange membrane. In the case in which whether the region corresponds to an opening or an exposed portion was not known, the area observed by the microscope describe above was observed as the target by a scanning electron microscope (SEM), and determination was made based on an SEM micrograph obtained at this time. That is, according to the SEM micrograph, a white region not dyed with dye that was dented from the surface of the membrane main body was determined as an opening, and a

- 84 -

white region that protruded from the surface of the membrane main body was determined as an exposed portion.

[0114]

When a continuous hole crosses an opening or exposed portion, the opening or exposed portion may be dyed with dye, and a white portion not dyed with dye may be observed in a partitioned state. In such a case, the opening and exposed portion was considered continuous without being partitioned by a continuous hole or the like, and the white region not dyed with dye was identified. When the ion exchange membrane had a coating layer, measurement was carried out after only the coating was removed using a mixed solution of water and ethanol and a soft brush.

[0115]

The area ratio of the opening portions were determined by first determining the total area of the white portions corresponding to the opening portions of the sample described above (opening area B) and dividing the opening area by the surface area of the sample ($2 \text{ mm} \times 3 \text{ mm} = 6 \text{ mm}^2$). The area ratio of the opening portions was the average value of the results obtained by measurement at nine positions of the ion exchange membrane ($N = 9$).

[0116]

[Method for measuring height and arrangement density of raised portions]

- 85 -

The height of raised portions and arrangement density were checked by the following method. First, in an area of a 1000- μm square of the surface of the ion exchange membrane, a point having the smallest height was taken as the reference. Portions having a height of 20 μm or more from the reference point were taken as raised portions. In this case, the height was measured using a "Color 3D Laser Microscope (VK-9710)" manufactured by KEYENCE CORPORATION. Specifically, a piece of 10 cm \times 10 cm was optionally cut out from the ion exchange membrane in a dry state. The cathode side of the ion exchange membrane was fixed on a flat plate with double-sided tape, and the membrane was mounted on the measuring stage such that the anode side of the ion exchange membrane faced the measuring lens. The shape on the surface of the ion exchange membrane was measured in a 1000- μm square measuring area of each 10 cm \times 10 cm membrane. A point having the smallest height was taken as the reference, and the height from the reference was measured to thereby to check raised portions. The arrangement density of raised portions was determined by optionally cutting out three 10 cm \times 10 cm pieces from the membrane, carrying out measurement at nine points across a 1000- μm square measuring area of each 10 cm \times 10 cm membrane, and averaging the measured values.

The area of the raised portions was checked as follows. That is, the surface of the obtained membrane

- 86 -

was observed in the embedding step (OLYMPUS SZX10) to obtain an image. On this image, raised portions were marked, and ¥USB Digital Scale 1.1J (manufactured by Scalar Corporation) was used as analysis software to calculate raised portions area/area other than the raised portions.

[0117]

[Measurement of ion exchange capacity]

As a fluorine-containing polymer having ion exchange groups, about 1 g of a fluorine-containing polymer A-1, a fluorine-containing polymer A-2, or a fluorine-containing polymer B in each example described below was used and press-formed at a temperature about 30°C higher than the pseudo-melting point of the polymer to obtain a film corresponding to each polymer. The obtained film was measured by a transmission infrared spectroscopic analyzer (FTIR-4200 manufactured by JASCO Corporation). From the height of each of the obtained infrared peaks CF_2 , CF , CH_3 , OH , and SO_2F , the proportion of structural units having groups that can be converted into carboxylic acid functional groups or sulfonic acid functional groups was calculated. The proportion was taken as the proportion of structural units having carboxylic acid functional groups or sulfonic acid functional groups obtained by hydrolyzing the fluorine-containing polymer, and a calibration curve of a sample having a known ion

exchange capacity calculated by a titration method was used to determine the ion exchange capacity.

[0118]

[Example 1]

Monomers represented by the following general formula (1) and monomers represented by the following general formula (2) were copolymerized to obtain a polymer having an ion exchange capacity of 1.05 meq/g, as a fluorine-containing polymer S-1.

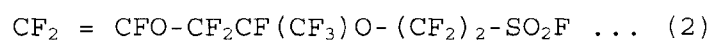
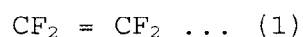

[0119]

Monomers represented by the general formula (1) and monomers represented by the general formula (2) were copolymerized to obtain a polymer having an ion exchange capacity of 1.03 meq/g, as a fluorine-containing polymer S-2.

[0120]

Monomers represented by the general formula (1) and monomers represented by the following general formula (3) were copolymerized to obtain a polymer having an ion exchange capacity of 0.87 meq/g, as a fluorine-containing polymer C-1.

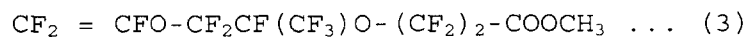

[0121]

The fluorine polymer S-2 and the fluorine polymer C-1 were provided and coextruded by an apparatus equipped

- 88 -

with two extruders, a T die for two layer extrusion, and a take-up apparatus to obtain a two-layer film (a) having a thickness of 67 μm . The observation result of the cross-section of the film obtained with an optical microscope showed that the thickness of the layer S-2 was 55 μm and the thickness of the layer C was 12 μm . Additionally, a single-layer T die was used to obtain a single-layer film of a layer S-1 (b) having a thickness of 20 μm .

[0122]

As reinforcement yarn, PTFE monofilament yarn having a yarn diameter of 90 deniers was provided. As sacrifice yarn, multifilament yarn formed by twisting and integrating six strands of PET having a yarn diameter of 6.7 deniers was provided. With the yarn density of the reinforcement yarn set to 24 strands/inch, plain-woven fabric was woven such that two strands of the sacrifice yarn were arranged between adjacent strands of the reinforcement yarn. The obtained woven fabric was pressure-bonded by a roll at 125 °C to obtain a strengthening material 1. The strengthening material 1 had a thickness of 80 μm .

[0123]

On a drum including a heat source and a vacuum source therein and having many micropores on the surface thereof, embossed breathable heat-resistant release paper, the single-layer film (b), the strengthening

- 89 -

material 1, and the two-layer film (a) were laminated in the order mentioned and integrated at a drum surface temperature of 230°C and under a reduced pressure of -650 mmHg while the air among each of the materials was evacuated to obtain a composite membrane. In the integration step, during the period from feeding of the materials to contact of the materials with the drum, the extension ratio of the single-layer film and two-layer film in the running direction was controlled to be 4% or less. As the result of observation of the surface of the obtained membrane, it was observed that hemispherical protruded portions having an average height of 60 μm constituted only by a polymer having ion exchange groups were formed on the anode-side film (b) at a density of 250 raised portions/cm² and the total area of the raised portions was 0.2 cm² per cm².

[0124]

This composite membrane was hydrolyzed in an aqueous solution containing 30 mass% of DMSO and 3.2 N KOH at 80°C for 0.5 hours, and then was subjected to salt exchange treatment under a condition of 50°C using a 0.6 N NaOH solution for 1 hour. Thereafter, the surface of the composite membrane was polished with a running tension set to 20 kg/cm, a relative speed between a polishing roll and the composite membrane set to 100 m/minute, and a press amount of the polishing roll set to

- 90 -

2 mm to form opening portions. The opening portions of the composite membrane had an area ratio of 2.4%.

[0125]

In a mixed solution of water and ethanol at 50/50 parts by mass, 20 wt% of a fluorine polymer having a sulfonic acid group that was obtained by hydrolyzing a copolymer of $\text{CF}_2 = \text{CF}_2$ and $\text{CF}_2 = \text{CFOCF}_2\text{CF}(\text{CF}_3)\text{O}(\text{CF}_2)_2\text{SO}_2\text{F}$ and had an ion exchange capacity of 1.08 meq/g was dissolved. To the solution, 40 wt% of zirconium oxide having a primary particle diameter of 1 μm was added and homogeneously dispersed in a ball mill to obtain a suspension liquid. This suspension liquid was applied by a spray method to both the surfaces of the ion exchange membrane after hydrolysis and dried to form coating layers.

[0126]

The average thickness, membrane strength, and electrolytic voltage of the ion exchange membrane obtained as described above were each measured. The evaluation results of the properties are shown in Table 1. The electrolytic voltage of 2.92 V was satisfactory. The membrane strength was 1.40 kgf/cm, and thus sufficient strength was maintained.

[0127]

[Example 2]

With use of the two-layer film (a), single-layer film (b), and reinforcement yarn used in Example 1, on a

- 91 -

drum including a heat source and a vacuum source therein and having many micropores on the surface thereof, embossed breathable heat-resistant release paper, the single-layer film (b), the strengthening material 1, and the two-layer film (a) were laminated in the order mentioned and integrated at a drum surface temperature of 230°C and under a reduced pressure of -650 mmHg. A heat insulating plate was placed so as not to come in contact with the films and the reinforcement yarn and so as to cover the upper portion and side portion of the pressure reducing section of the drum. In a state in which the films were prevented from being cooled by outside air, the laminated materials were integrated while the air among each of the materials was evacuated to obtain a composite membrane. In the integration step, during the period from feeding of the materials to contact of the materials with the drum, the extension ratio of the single-layer film and two-layer film in the running direction was controlled to be 4% or less. As the result of observation of the surface of the obtained membrane, it was observed that hemispherical protruded portions having an average height of 60 μm constituted only by a polymer having ion exchange groups were formed on the anode-side film (b) at a density of 250 raised portions/cm² and the total area of the raised portions was 0.2 cm² per cm².

[0128]

This composite membrane was hydrolyzed in an aqueous solution containing 30 mass% of DMSO and 3.2 N KOH at 80°C for 0.5 hours, and then was subjected to salt exchange treatment under a condition of 50°C using a 0.6 N NaOH solution for 1 hour. Thereafter, the surface of the composite membrane was polished with a running tension set to 20 kg/cm, a relative speed between a polishing roll and the composite membrane set to 100 m/minute, and a press amount of the polishing roll set to 2 mm to form opening portions. The opening portions of the composite membrane had an area ratio of 2.2%.

[0129]

In a mixed solution of water and ethanol at 50/50 parts by mass, 20 wt% of a fluorine polymer having a sulfonic acid group that was obtained by hydrolyzing a copolymer of $\text{CF}_2 = \text{CF}_2$ and $\text{CF}_2 = \text{CFOCF}_2\text{CF}(\text{CF}_3)\text{O}(\text{CF}_2)_2\text{SO}_2\text{F}$ and had an ion exchange capacity of 1.08 meq/g was dissolved. To the solution, 40 wt% of zirconium oxide having a primary particle diameter of 1 μm was added and homogeneously dispersed in a ball mill to obtain a suspension liquid. This suspension liquid was applied by a spray method to both the surfaces of the ion exchange membrane after hydrolysis and dried to form coating layers.

[0130]

The average thickness, membrane strength, and electrolytic voltage of the ion exchange membrane obtained as described above were each measured. The evaluation results of the properties are shown in Table 1. The electrolytic voltage of 2.91 V was more satisfactory than that of Example 1. The membrane strength was 1.35 kgf/cm, and thus sufficient strength was maintained.

[0131]

[Comparative Example 1]

With use of the two-layer film (a), single-layer film (b), and reinforcement yarn used in Example 1, on a drum including a heat source and a vacuum source therein and having many micropores on the surface thereof, embossed breathable heat-resistant release paper, the single-layer film (b), the strengthening material 1, and the two-layer film (a) were laminated in the order mentioned and integrated at a drum surface temperature of 230°C and under a reduced pressure of -650 mmHg. A heat insulating plate was placed so as not to come in contact with the films and the reinforcement yarn and so as to cover the upper portion and side portion of the pressure reducing section of the drum. In a state in which hot air at 230°C was allowed to flow inside the heat insulation plate, the laminated materials were integrated while the air among each of the materials was evacuated

- 94 -

to obtain a composite membrane. In the integration step, during the period from feeding of the materials to contact of the materials with the drum, the extension ratio of the single-layer film and two-layer film in the running direction was controlled to be 6 to 8%. As the result of observation of the surface of the obtained membrane, it was observed that hemispherical protruded portions having an average height of 60 μm constituted only by a polymer having ion exchange groups were formed on the anode-side film (b) at a density of 250 raised portions/ cm^2 and the total area of the raised portions was 0.2 cm^2 per cm^2 .

[0132]

This composite membrane was hydrolyzed in an aqueous solution containing 30 mass% of DMSO and 3.2 N KOH at 80°C for 0.5 hours, and then was subjected to salt exchange treatment under a condition of 50°C using a 0.6 N NaOH solution for 1 hour. Thereafter, the surface of the composite membrane was polished with a running tension set to 20 kg/cm, a relative speed between a polishing roll and the composite membrane set to 100 m/minute, and a press amount of the polishing roll set to 2 mm to form opening portions. The opening portions of the composite membrane had an area ratio of 2.1%.

[0133]

In a mixed solution of water and ethanol at 50/50 parts by mass, 20 wt% of a fluorine polymer having a

- 95 -

sulfonic acid group that was obtained by hydrolyzing a copolymer of $\text{CF}_2 = \text{CF}_2$ and $\text{CF}_2 = \text{CFOCF}_2\text{CF}(\text{CF}_3)\text{O}(\text{CF}_2)_2\text{SO}_2\text{F}$ and had an ion exchange capacity of 1.08 meq/g was dissolved. To the solution, 40 wt% of zirconium oxide having a primary particle diameter of 1 μm was added and homogeneously dispersed in a ball mill to obtain a suspension liquid. This suspension liquid was applied by a spray method to both the surfaces of the ion exchange membrane after hydrolysis and dried to form coating layers.

[0134]

The average thickness, membrane strength, and electrolytic voltage of the ion exchange membrane obtained as described above were each measured. The evaluation results of the properties are shown in Table 1. The electrolytic voltage was 2.93 V, which was higher than that of Example 2 despite the small average thickness A. Additionally, the variation in the electrolytic voltage due to adsorption and desorption of gas increased more than in Examples 1 and 2. In contrast, the membrane strength was considerably reduced to 0.95 kgf/cm.

[0135]

[Comparative Example 2]

The fluorine polymer S-2 and fluorine polymer C-1 used in Example 1 were provided and coextruded by an apparatus equipped with two extruders, a T die for two

- 96 -

layer extrusion, and a take-up apparatus to obtain a two-layer film (c) having a thickness of 77 μm . The observation result of the cross-section of the film obtained with an optical microscope showed that the thickness of the layer S-2 was 65 μm and the thickness of the layer C was 12 μm .

[0136]

With use of the above two-layer film (c) and the single-layer film (b) and reinforcement yarn used in Example 1, on a drum including a heat source and a vacuum source therein and having many micropores on the surface thereof, embossed breathable heat-resistant release paper, the single-layer film (b), the strengthening material 1, and the two-layer film (a) were laminated in the order mentioned and integrated at a drum surface temperature of 230°C and under a reduced pressure of -650 mmHg while the air among each of the materials was evacuated to obtain a composite membrane. In the integration step, during the period from feeding of the materials to contact of the materials with the drum, the extension ratio of the single-layer film and two-layer film in the running direction was controlled to be 2.5% or less. As the result of observation of the surface of the obtained membrane, it was observed that hemispherical protruded portions having an average height of 60 μm constituted only by a polymer having ion exchange groups were formed on the anode-side film (b) at a density of

- 97 -

250 raised portions/cm² and the total area of the raised portions was 0.2 cm² per cm².

[0137]

This composite membrane was hydrolyzed in an aqueous solution containing 30 mass% of DMSO and 3.2 N KOH at 80°C for 0.5 hours, and then was subjected to salt exchange treatment under a condition of 50°C using a 0.6 N NaOH solution for 1 hour. Thereafter, the surface of the composite membrane was polished with a running tension set to 20 kg/cm, a relative speed between a polishing roll and the composite membrane set to 100 m/minute, and a press amount of the polishing roll set to 2 mm to form opening portions. The opening portions of the composite membrane had an area ratio of 2.5%.

[0138]

In a mixed solution of water and ethanol at 50/50 parts by mass, 20 wt% of a fluorine polymer having a sulfonic acid group that was obtained by hydrolyzing a copolymer of $\text{CF}_2 = \text{CF}_2$ and $\text{CF}_2 = \text{CFOCF}_2\text{CF}(\text{CF}_3)\text{O}(\text{CF}_2)_2\text{SO}_2\text{F}$ and had an ion exchange capacity of 1.08 meq/g was dissolved. To the solution, 40 wt% of zirconium oxide having a primary particle diameter of 1 μm was added and homogeneously dispersed in a ball mill to obtain a suspension liquid. This suspension liquid was applied by a spray method to both the surfaces of the ion exchange membrane after hydrolysis and dried to form coating layers.

[0139]

The average thickness, membrane strength, and electrolytic voltage of the ion exchange membrane obtained as described above were each measured. The evaluation results of the properties are shown in Table 1. The electrolytic voltage was 2.96 V, which was high. Meanwhile, the membrane strength was 1.50 kgf/cm, and the strength required for the ion exchange membrane was maintained.

[0140]

[Comparative Example 3]

With use of the above two-layer film (c), single-layer film (b), and reinforcement yarn used in Comparative Example 2, on a drum including a heat source and a vacuum source therein and having many micropores on the surface thereof, embossed breathable heat-resistant release paper, the single-layer film (b), the strengthening material 1, and the two-layer film (c) were laminated in the order mentioned and integrated at a drum surface temperature of 230°C and under a reduced pressure of -650 mmHg. A heat insulating plate was placed so as not to come in contact with the films and the reinforcement yarn and so as to cover the upper portion and side portion of the pressure reducing section of the drum. In a state in which hot air at 230°C was allowed to flow inside the heat insulation plate, the laminated materials were integrated while the air among each of the

materials was evacuated to obtain a composite membrane. In the integration step, during the period from feeding of the materials to contact of the materials with the drum, the extension ratio of the single-layer film and two-layer film in the running direction was controlled to be 6 to 8%. As the result of observation of the surface of the obtained membrane, it was observed that hemispherical protruded portions having an average height of 60 μm constituted only by a polymer having ion exchange groups were formed on the anode-side film (b) at a density of 250 raised portions/ cm^2 and the total area of the raised portions was 0.2 cm^2 per cm^2 .

[0141]

This composite membrane was hydrolyzed in an aqueous solution containing 30 mass% of DMSO and 3.2 N KOH at 80°C for 0.5 hours, and then was subjected to salt exchange treatment under a condition of 50°C using a 0.6 N NaOH solution for 1 hour. Thereafter, the surface of the composite membrane was polished with a running tension set to 20 kg/cm, a relative speed between a polishing roll and the composite membrane set to 100 m/minute, and a press amount of the polishing roll set to 2 mm to form opening portions. The opening portions of the composite membrane had an area ratio of 2.0%.

[0142]

In a mixed solution of water and ethanol at 50/50 parts by mass, 20 wt% of a fluorine polymer having a

- 100 -

sulfonic acid group that was obtained by hydrolyzing a copolymer of $\text{CF}_2 = \text{CF}_2$ and $\text{CF}_2 = \text{CFOCF}_2\text{CF}(\text{CF}_3)\text{O}(\text{CF}_2)_2\text{SO}_2\text{F}$ and had an ion exchange capacity of 1.08 meq/g was dissolved. To the solution, 40 wt% of zirconium oxide having a primary particle diameter of 1 μm was added and homogeneously dispersed in a ball mill to obtain a suspension liquid. This suspension liquid was applied by a spray method to both the surfaces of the ion exchange membrane after hydrolysis and dried to form coating layers.

[0143]

The average thickness, membrane strength, and electrolytic voltage of the ion exchange membrane obtained as described above were each measured. The evaluation results of the properties are shown in Table 1. The electrolytic voltage was 2.94 V, which was high. Additionally, the variation in the electrolytic voltage due to adsorption and desorption of gas increased more than in Examples 1 and 2. In contrast, the membrane strength was 1.25 kgf/cm, and the strength required for the ion exchange membrane was maintained.

[0144]

[Example 3]

Monomers represented by the above general formula (1) and monomers represented by the following above general formula (3) were copolymerized to obtain a

- 101 -

polymer having an ion exchange capacity of 0.85 meq/g, as a fluorine-containing polymer C-2.

[0145]

The above fluorine polymer C-2 and the fluorine polymer S-2 used in Example 1 were provided and coextruded by an apparatus equipped with two extruders, a T die for two layer extrusion, and a take-up apparatus to obtain a two-layer film (e) having a thickness of 57 μm . The observation result of the cross-section of the film obtained with an optical microscope showed that the thickness of the layer S-2 was 45 μm and the thickness of the layer C was 12 μm . Additionally, with use of the fluorine polymer S-1 used in Example 1, a single-layer T die was used to obtain a single-layer film of the layer S-1 (f) having a thickness of 12 μm .

[0146]

With use of the above two-layer film (e) and single-layer film (b) and the reinforcement yarn utilized in Example 1, on a drum including a heat source and a vacuum source therein and having many micropores on the surface thereof, embossed breathable heat-resistant release paper, the single-layer film (f), the strengthening material 1, and the two-layer film (e) were laminated in the order mentioned and integrated at a drum surface temperature of 230°C and under a reduced pressure of -650 mmHg while the air among each of the materials was evacuated to obtain a composite membrane. In the

- 102 -

integration step, during the period from feeding of the materials to contact of the materials with the drum, the extension ratio of the single-layer film and two-layer film in the running direction was controlled to be 3% or less. As the result of observation of the surface of the obtained membrane, it was observed that hemispherical protruded portions having an average height of 60 μm constituted only by a polymer having ion exchange groups were formed on the anode-side film (b) at a density of 250 raised portions/ cm^2 and the total area of the raised portions was 0.2 cm^2 per cm^2 .

[0147]

This composite membrane was hydrolyzed in an aqueous solution containing 30 mass% of DMSO and 3.2 N KOH at 80°C for 0.5 hours, and then was subjected to salt exchange treatment under a condition of 50°C using a 0.6 N NaOH solution. Thereafter, the surface of the composite membrane was polished with a running tension set to 20 kg/cm, a relative speed between a polishing roll and the composite membrane set to 100 m/minute, and a press amount of the polishing roll set to 2 mm to form opening portions. The opening portions of the composite membrane had an area ratio of 3.0%.

[0148]

In a mixed solution of water and ethanol at 50/50 parts by mass, 20 wt% of a fluorine polymer having a sulfonic acid group that was obtained by hydrolyzing a

- 103 -

copolymer of $\text{CF}_2 = \text{CF}_2$ and $\text{CF}_2 = \text{CFOCF}_2\text{CF}(\text{CF}_3)\text{O}(\text{CF}_2)_2\text{SO}_2\text{F}$ and had an ion exchange capacity of 1.08 meq/g was dissolved. To the solution, 40 wt% of zirconium oxide having a primary particle diameter of 1 μm was added and homogeneously dispersed in a ball mill to obtain a suspension liquid. This suspension liquid was applied by a spray method to both the surfaces of the ion exchange membrane after hydrolysis and dried to form coating layers.

[0149]

The average thickness, membrane strength, and electrolytic voltage of the ion exchange membrane obtained as described above were each measured. The evaluation results of the properties are shown in Table 1. The electrolytic voltage was 2.92 V, which was a low voltage. The membrane strength was 1.35 kgf/cm, and the strength required for the ion exchange membrane was maintained.

[0150]

[Comparative Example 4]

With use of the two-layer film (e), single-layer film (f), and reinforcement yarn used in Example 3, on a drum including a heat source and a vacuum source therein and having many micropores on the surface thereof, embossed breathable heat-resistant release paper, the single-layer film (f), the strengthening material 1, and the two-layer film (e) were laminated in the order

- 104 -

mentioned and integrated at a drum surface temperature of 230°C and under a reduced pressure of -650 mmHg. A heat insulating plate was placed so as not to come in contact with the films and the reinforcement yarn and so as to cover the upper portion and side portion of the pressure reducing section of the drum. In a state in which hot air at 230°C was allowed to flow inside the heat insulation plate, the laminated materials were integrated while the air among each of the materials was evacuated to obtain a composite membrane. In the integration step, during the period from feeding of the materials to contact of the materials with the drum, the extension ratio of the single-layer film and two-layer film in the running direction was controlled to be 5 to 7%. As the result of observation of the surface of the obtained membrane, it was observed that hemispherical protruded portions having an average height of 60 μm constituted only by a polymer having ion exchange groups were formed on the anode-side film (b) at a density of 250 raised portions/ cm^2 and the total area of the raised portions was 0.2 cm^2 per cm^2 .

[0151]

This composite membrane was hydrolyzed in an aqueous solution containing 30 mass% of DMSO and 3.2 N KOH at 80°C for 0.5 hours, and then was subjected to salt exchange treatment under a condition of 50°C using a 0.6 N NaOH solution. Thereafter, the surface of the

- 105 -

composite membrane was polished with a running tension set to 20 kg/cm, a relative speed between a polishing roll and the composite membrane set to 100 m/minute, and a press amount of the polishing roll set to 2 mm to form opening portions. The opening portions of the composite membrane had an area ratio of 2.8%.

[0152]

In a mixed solution of water and ethanol at 50/50 parts by mass, 20 wt% of a fluorine polymer having a sulfonic acid group that was obtained by hydrolyzing a copolymer of $CF_2 = CF_2$ and $CF_2 = CFOCF_2CF(CF_3)O(CF_2)_2SO_2F$ and had an ion exchange capacity of 1.08 meq/g was dissolved. To the solution, 40 wt% of zirconium oxide having a primary particle diameter of 1 μm was added and homogeneously dispersed in a ball mill to obtain a suspension liquid. This suspension liquid was applied by a spray method to both the surfaces of the ion exchange membrane after hydrolysis and dried to form coating layers.

[0153]

The average thickness, membrane strength, and electrolytic voltage of the ion exchange membrane obtained as described above were each measured. The evaluation results of the properties are shown in Table 1. The electrolytic voltage was 2.92 V, and no reduction in the voltage was observed despite the average thickness A smaller than that of Example 3. Additionally, the

- 106 -

variation in the electrolytic voltage due to adsorption and desorption of gas increased more than in Example 3. In contrast, the membrane strength was considerably reduced to 0.95 kgf/cm.

[0154]

[Comparative Example 5]

The fluorine polymer C-2 and the fluorine polymer S-2 used in Example 3 were provided and coextruded by an apparatus equipped with two extruders, a T die for two layer extrusion, and a take-up apparatus to obtain a two-layer film (g) having a thickness of 87 μm . The observation result of the cross-section of the film obtained with an optical microscope showed that the thickness of the layer S-2 was 75 μm and the thickness of the layer C was 12 μm .

[0155]

With use of the above two-layer film (g) and the single-layer film (f) and reinforcement yarn used in Example 3, on a drum including a heat source and a vacuum source therein and having many micropores on the surface thereof, embossed breathable heat-resistant release paper, the single-layer film (f), the strengthening material 1, and the two-layer film (g) were laminated in the order mentioned and integrated at a drum surface temperature of 230°C and under a reduced pressure of -650 mmHg. A heat insulating plate was placed so as not to come in contact with the films and the reinforcement yarn

- 107 -

and so as to cover the upper portion and side portion of the pressure reducing section of the drum. In a state in which hot air at 230°C was allowed to flow inside the heat insulation plate, the laminated materials were integrated while the air among each of the materials was evacuated to obtain a composite membrane. In the integration step, during the period from feeding of the materials to contact of the materials with the drum, the extension ratio of the single-layer film and two-layer film in the running direction was controlled to be 3% or less. As the result of observation of the surface of the obtained membrane, it was observed that hemispherical protruded portions having an average height of 60 μm constituted only by a polymer having ion exchange groups were formed on the anode-side film (b) at a density of 250 raised portions/ cm^2 and the total area of the raised portions was 0.2 cm^2 per cm^2 .

[0156]

This composite membrane was hydrolyzed in an aqueous solution containing 30 mass% of DMSO and 3.2 N KOH at 80°C for 0.5 hours, and then was subjected to salt exchange treatment under a condition of 50°C using a 0.6 N NaOH solution. Thereafter, the surface of the composite membrane was polished with a running tension set to 20 kg/cm, a relative speed between a polishing roll and the composite membrane set to 100 m/minute, and a press amount of the polishing roll set to 2 mm to form

opening portions. The opening portions of the composite membrane had an area ratio of 2.7%.

[0157]

In a mixed solution of water and ethanol at 50/50 parts by mass, 20 wt% of a fluorine polymer having a sulfonic acid group that was obtained by hydrolyzing a copolymer of $\text{CF}_2 = \text{CF}_2$ and $\text{CF}_2 = \text{CFOCF}_2\text{CF}(\text{CF}_3)\text{O}(\text{CF}_2)_2\text{SO}_2\text{F}$ and had an ion exchange capacity of 1.08 meq/g was dissolved. To the solution, 40 wt% of zirconium oxide having a primary particle diameter of 1 μm was added and homogeneously dispersed in a ball mill to obtain a suspension liquid. This suspension liquid was applied by a spray method to both the surfaces of the ion exchange membrane after hydrolysis and dried to form coating layers.

[0158]

The average thickness, membrane strength, and electrolytic voltage of the ion exchange membrane obtained as described above were each measured. The evaluation results of the properties are shown in Table 1. The electrolytic voltage was 2.96 V, which was high. In contrast, the membrane strength was 1.50 kgf/cm, and the strength required for the ion exchange membrane was maintained.

[0159]

[Example 4]

With use of a strengthening material 2 having a thickness of 65 μm , which was produced in the same manner as for the strengthening material 1 described in Example 1 using a multifilament yarn formed by twisting PTFE having a yarn diameter of 70 deniers as the reinforcement yarn and six strands of PET each having a yarn diameter of 5 deniers as the sacrifice yarn, and the two-layer film (e) and single-layer film (f) used in Example 3, on a drum including a heat source and a vacuum source therein and having many micropores on the surface thereof, embossed breathable heat-resistant release paper, the single-layer film (f), the strengthening material 2, and the two-layer film (e) were laminated in the order mentioned and integrated at a drum surface temperature of 230°C and under a reduced pressure of -650 mmHg while the air among each of the materials was evacuated to obtain a composite membrane. In the integration step, during the period from feeding of the materials to contact of the materials with the drum, the extension ratio of the single-layer film and two-layer film in the running direction was controlled to be 3% or less. As the result of observation of the surface of the obtained membrane, it was observed that hemispherical protruded portions having an average height of 60 μm constituted only by a polymer having ion exchange groups

- 110 -

were formed on the anode-side film (b) at a density of 250 raised portions/cm² and the total area of the raised portions was 0.2 cm² per cm².

[0160]

This composite membrane was hydrolyzed in an aqueous solution containing 30 mass% of DMSO and 3.2 N KOH at 80°C for 0.5 hours, and then was subjected to salt exchange treatment under a condition of 50°C using a 0.6 N NaOH solution. Thereafter, the surface of the composite membrane was polished with a running tension set to 20 kg/cm, a relative speed between a polishing roll and the composite membrane set to 100 m/minute, and a press amount of the polishing roll set to 2 mm to form opening portions. The opening portions of the composite membrane had an area ratio of 2.9%.

[0161]

In a mixed solution of water and ethanol at 50/50 parts by mass, 20 wt% of a fluorine polymer having a sulfonic acid group that was obtained by hydrolyzing a copolymer of $\text{CF}_2 = \text{CF}_2$ and $\text{CF}_2 = \text{CFOCF}_2\text{CF}(\text{CF}_3)\text{O}(\text{CF}_2)_2\text{SO}_2\text{F}$ and had an ion exchange capacity of 1.08 meq/g was dissolved. To the solution, 40 wt% of zirconium oxide having a primary particle diameter of 1 μm was added and homogeneously dispersed in a ball mill to obtain a suspension liquid. This suspension liquid was applied by a spray method to both the surfaces of the ion exchange

- 111 -

membrane after hydrolysis and dried to form coating layers.

[0162]

The average thickness, membrane strength, and electrolytic voltage of the ion exchange membrane obtained as described above were each measured. The evaluation results of the properties are shown in Table 1. The electrolytic voltage was 2.92 V, which was a low voltage. The membrane strength was 1.35 kgf/cm, and the strength required for the ion exchange membrane was maintained.

[0163]

[Table 1]

	A	B	C1	C2	B/A	Electrolytic voltage (V)	Membrane strength (kgf/cm)
Example 1	90	215	110	100	2.39	2.92	1.4
Example 2	65	220	110	100	3.38	2.91	1.35
Comparative Example 1	35	235	110	100	6.71	2.93	0.95
Comparative Example 2	115	225	110	100	1.96	2.96	1.5
Comparative Example 3	45	240	110	100	5.33	2.94	1.25
Example 3	80	200	110	100	2.50	2.92	1.35
Comparative Example 4	30	215	110	100	7.17	2.92	0.95
Comparative Example 5	85	245	110	100	2.88	2.96	1.5
Example 4	80	175	100	90	2.19	2.92	1.35

[0164]

The present application is based on Japanese Patent Application filed on January 27th, 2017 (Japanese Patent Application No. 2017-013283).

Claims**[Claim 1]**

An ion exchange membrane comprising:

a layer S comprising a fluorine-containing polymer having a sulfonic acid group;

a layer C comprising a fluorine-containing polymer having a carboxylic acid group; and

a plurality of strengthening materials arranged inside the layer S and functioning as at least one of reinforcement yarn and sacrifice yarn;

wherein A and B, both of which are defined below, satisfy following formulas (1) and (2):

$$B \leq 240 \mu\text{m} \dots (1)$$

$$2.0 \leq B/A \leq 5.0 \dots (2)$$

wherein, when the ion exchange membrane is viewed from a top surface,

A represents an average cross-sectional thickness of the membrane measured in pure water for a region free of strengthening materials, and

B represents an average value of the largest thickness among cross-sectional thickness of the membrane measured in pure water for a region, in which strands of the reinforcement yarn overlap with each other, and for a region, in which the reinforcement yarn overlaps with the sacrifice yarn, wherein at least one of the strengthening materials is the reinforcement yarn.

[Claim 2]

The ion exchange membrane according to claim **1**, wherein A and C1 which is defined below satisfy following formula (3):

$$40 \mu\text{m} \leq A \leq C1 \dots (3)$$

wherein C1 represents a maximum value of a distance between a surface of the layer S and reinforcement yarn most distant from the surface of the layer S, the distance being measured in pure water and in a direction of the thickness of the membrane in the region, in which strands of the reinforcement yarn overlap with each other.

[Claim 3]

The ion exchange membrane according to claim **1** or **2**, wherein

the layer S has a continuous hole therein and a plurality of opening portions on the surface thereof, and

a ratio of a total area of the opening portions to an area of the surface of the layer S is 0.4 to 15%.

[Claim 4]

The ion exchange membrane according to any one of claims **1** to **3**, wherein the surface of the layer S has raised portions having a height of 20 μm or more, when viewed from a cross section.

[Claim 5]

The ion exchange membrane according to claim **4**, wherein an arrangement density of the raised portions is 20 to 1500 raised portions/cm².

[Claim 6]

An electrolyzer comprising the ion exchange membrane according to any one of claims **1** to **5**.

[Figure 2]

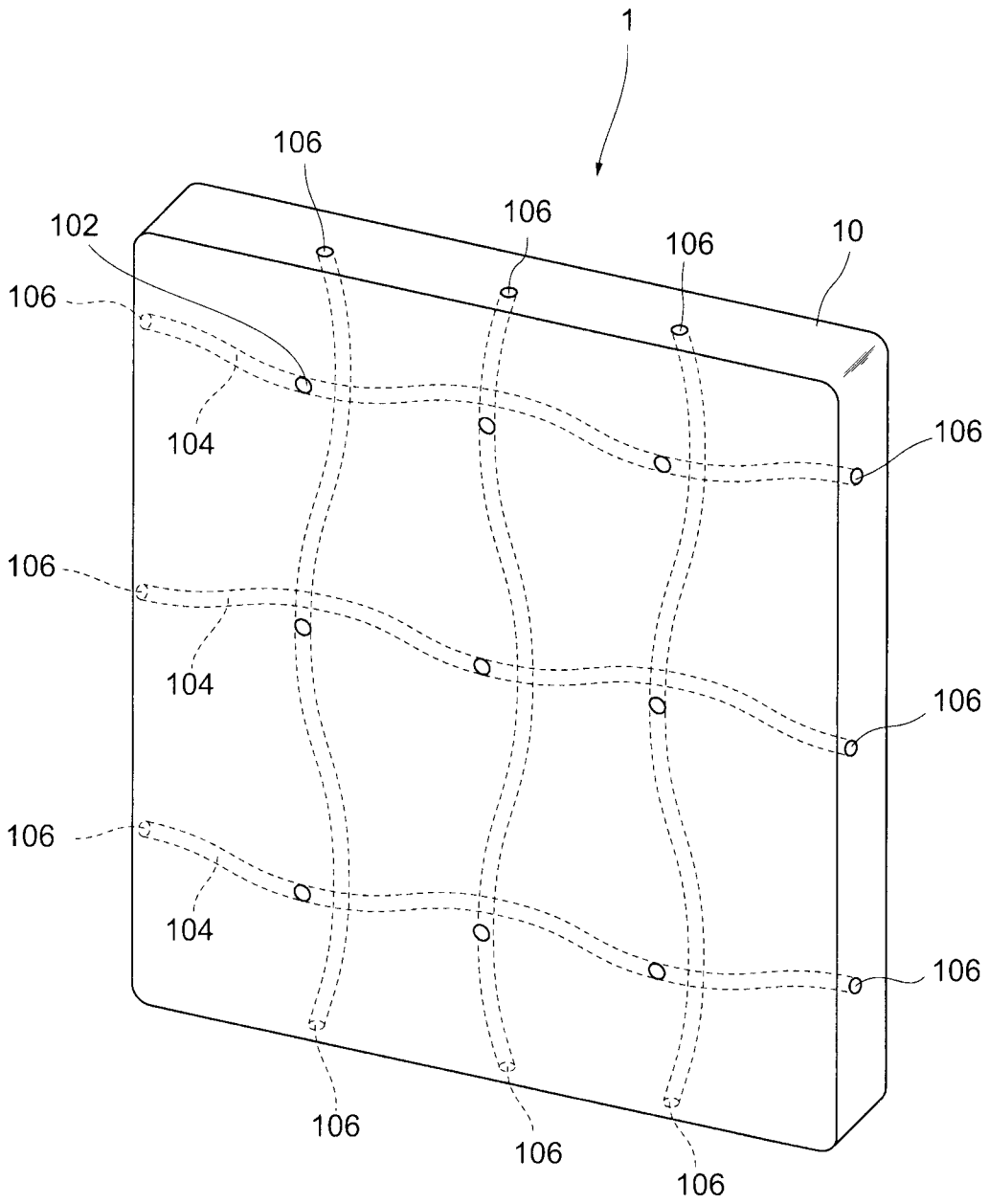

[Figure 3]

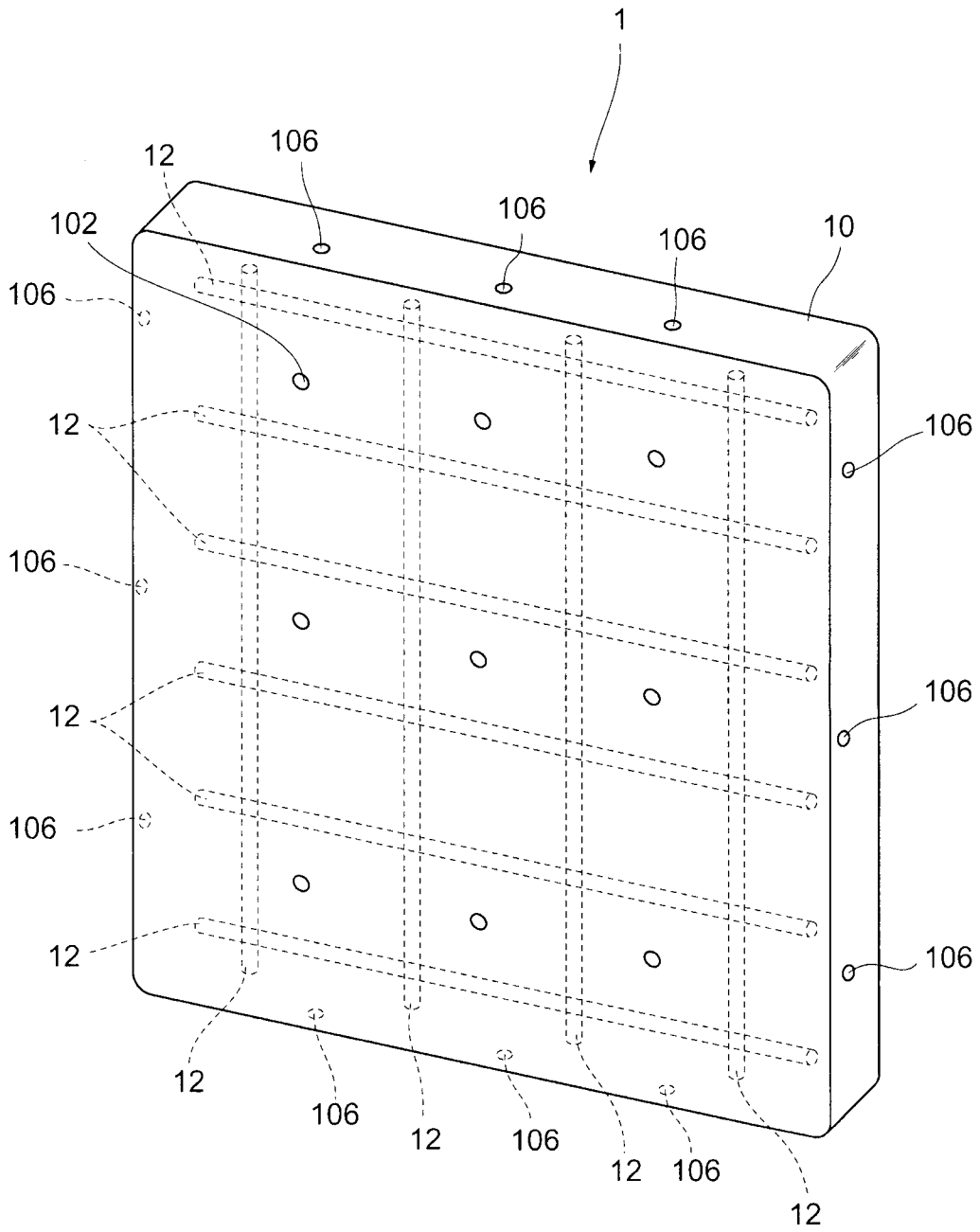

[Figure 4]

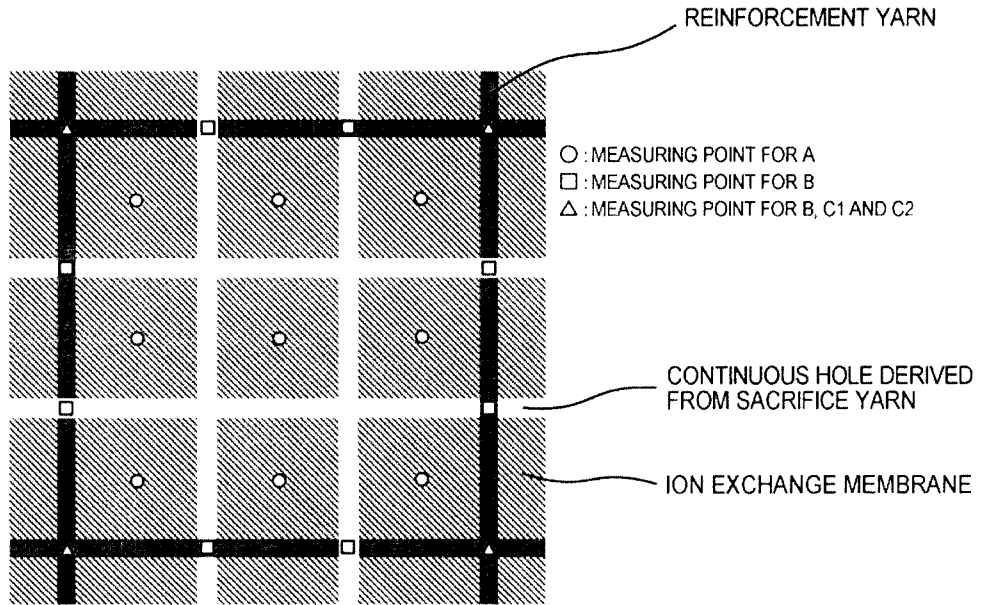

[Figure 5]

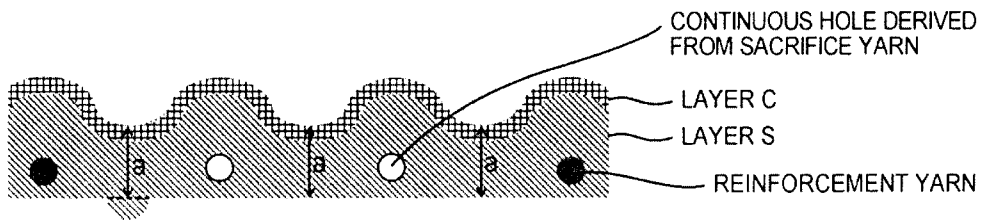

[Figure 6]

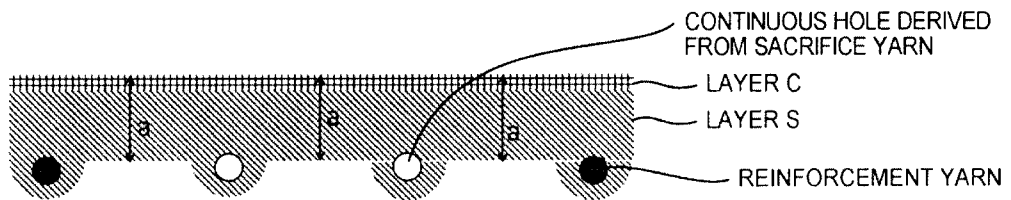

[Figure 7]

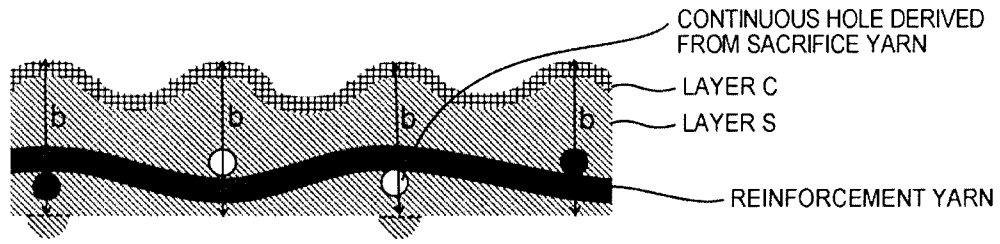

[Figure 8]

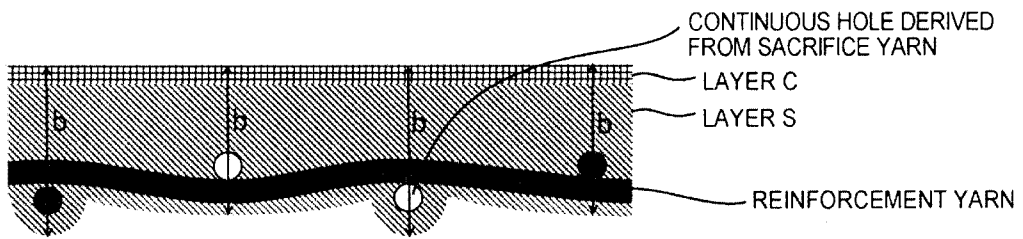

[Figure 9]

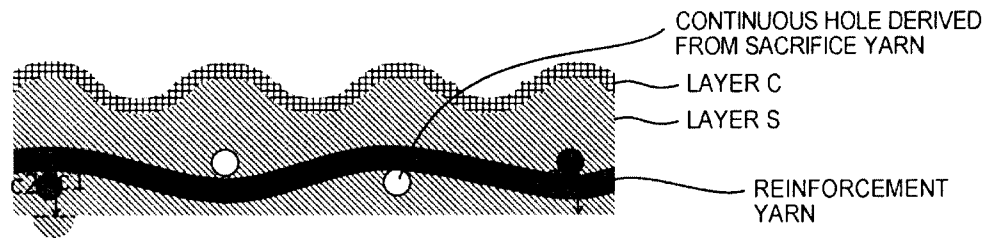

[Figure 10]

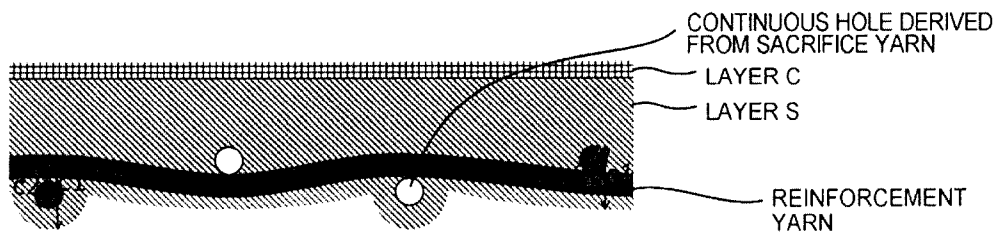

[Figure 11]

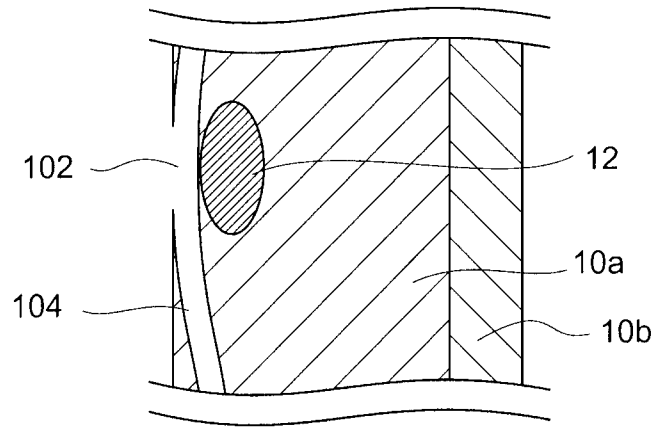

[Figure 12]

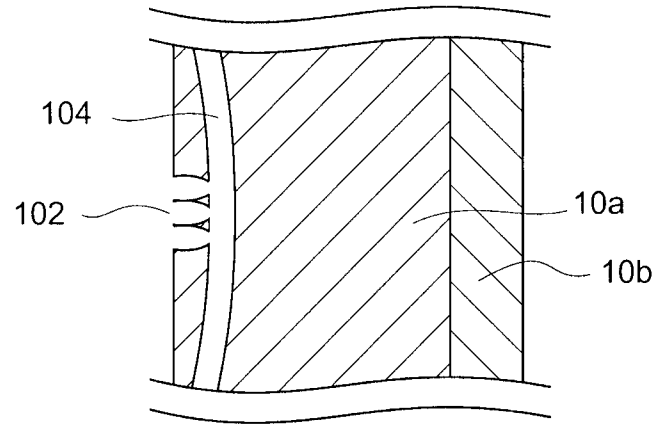

[Figure 13]

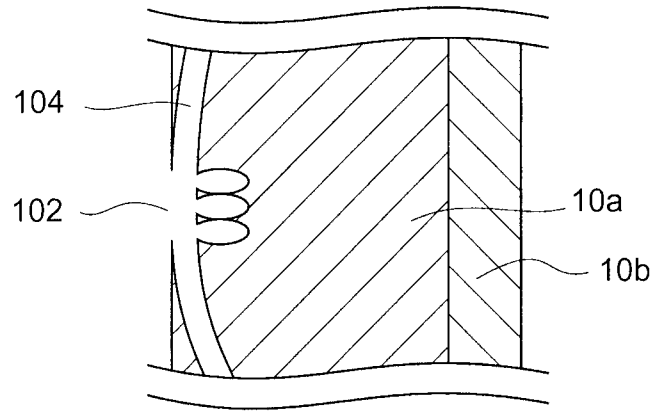

[Figure 14]

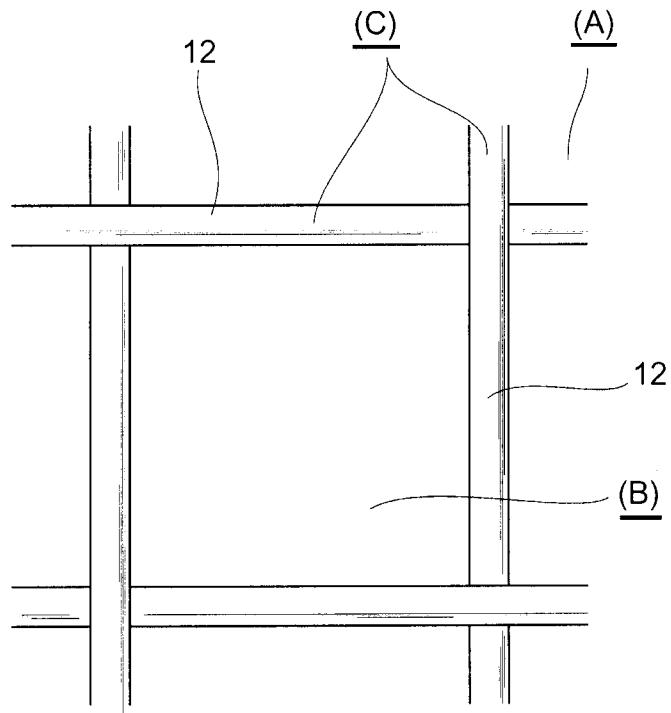

$$(B) = (A) - (C)$$
$$(B)/(A) = ((A) - (C))/(A)$$

[Figure 15]

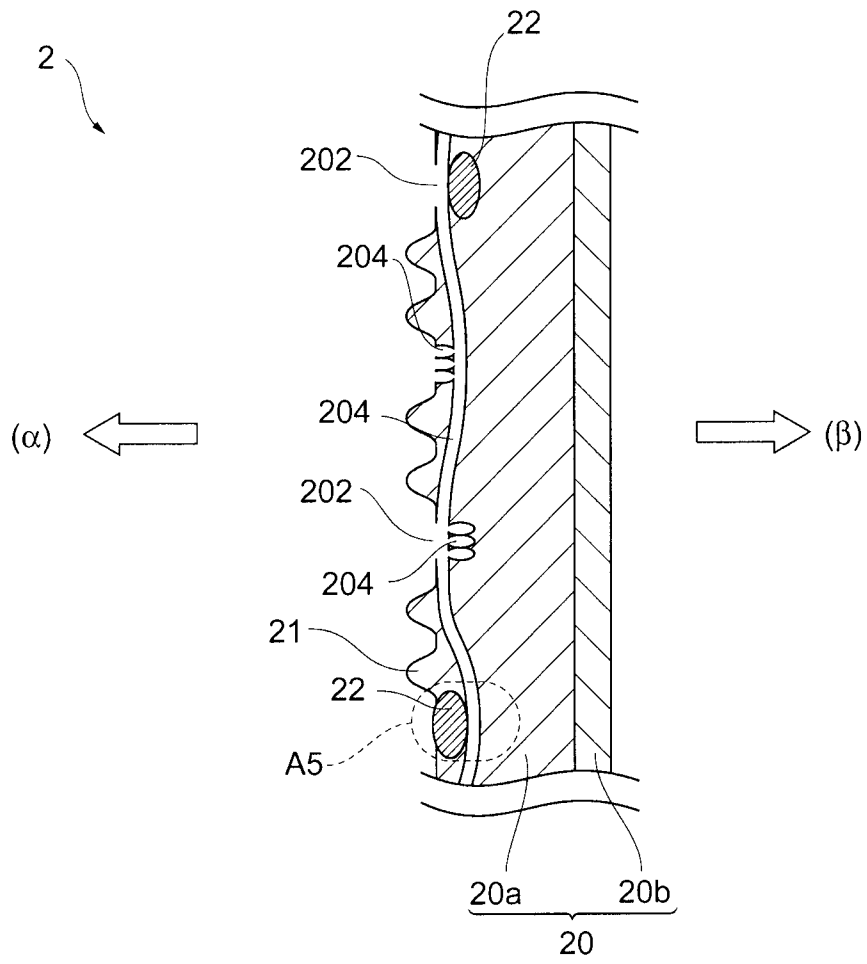

[Figure 16]

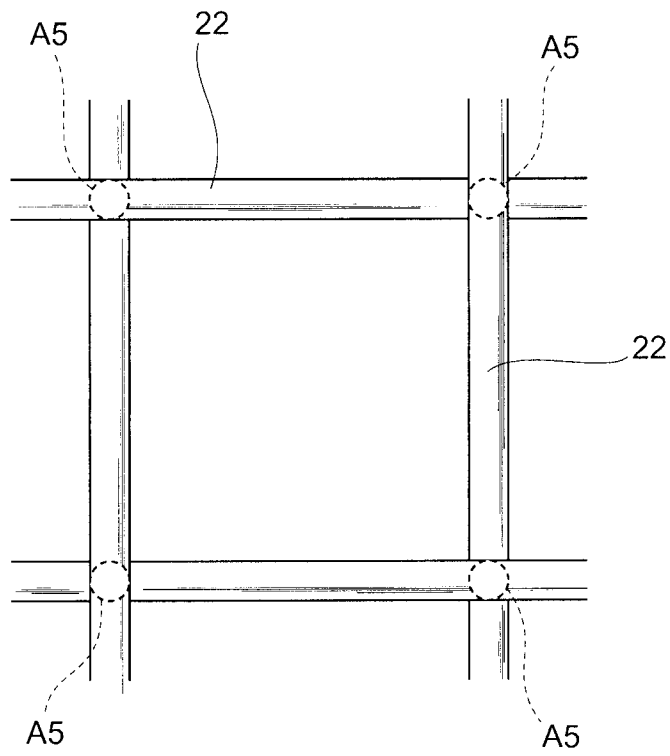

[Figure 17]

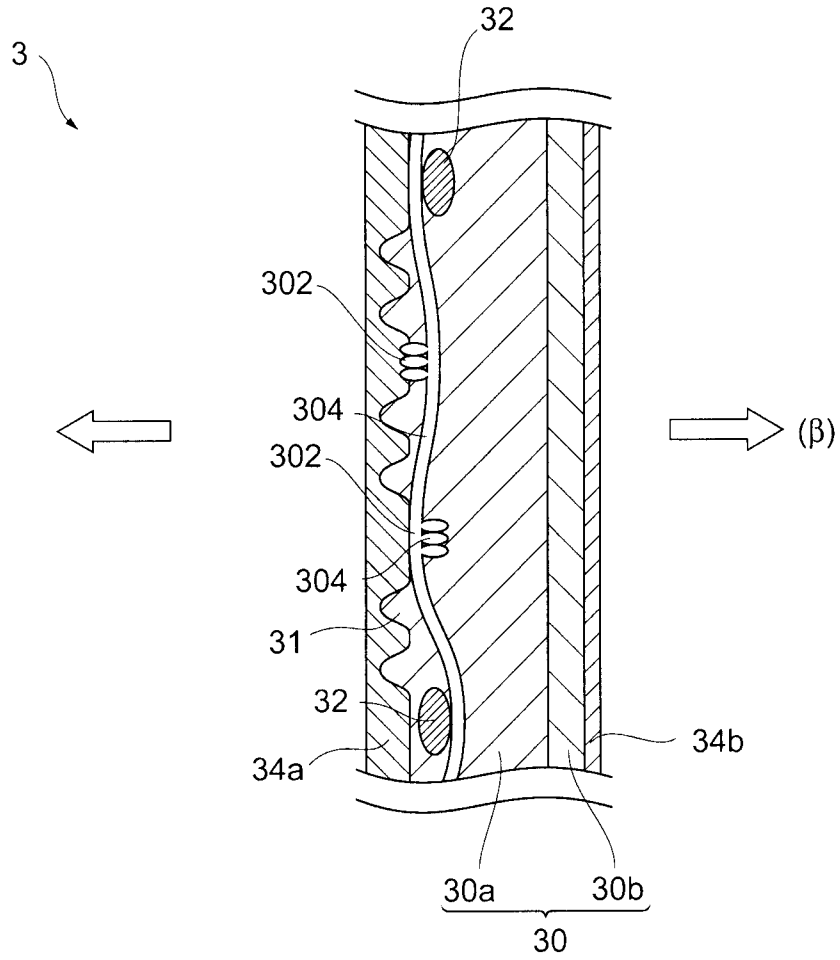

[Figure 18]

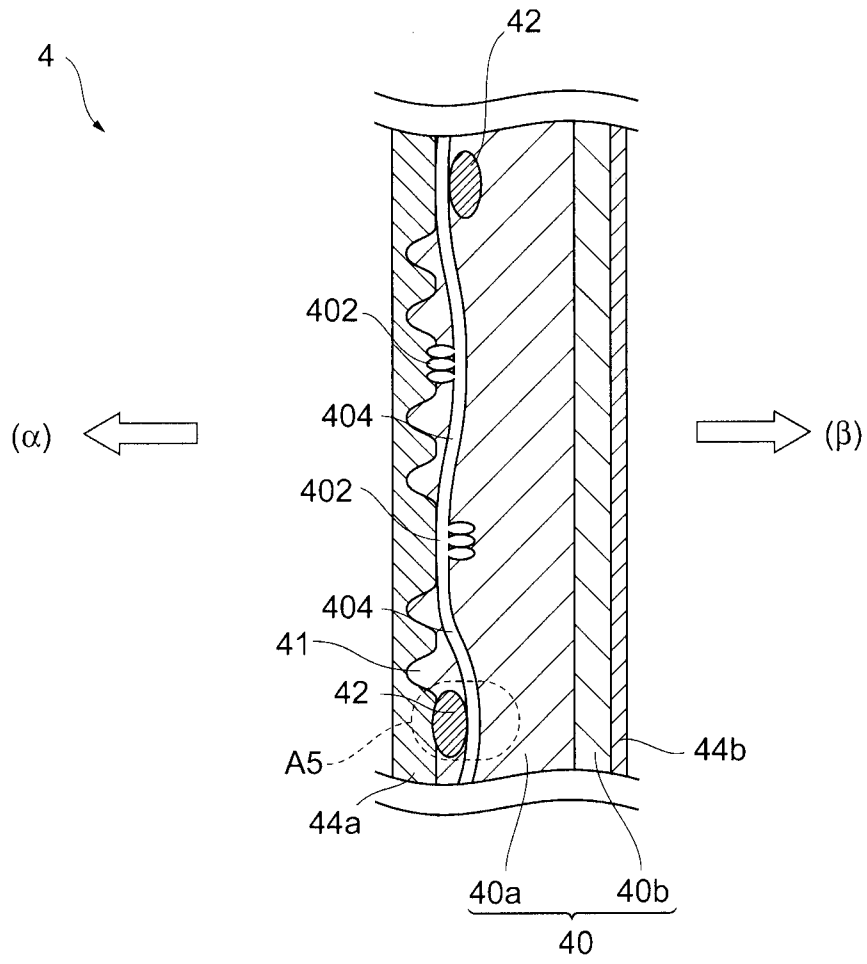

[Figure 19]

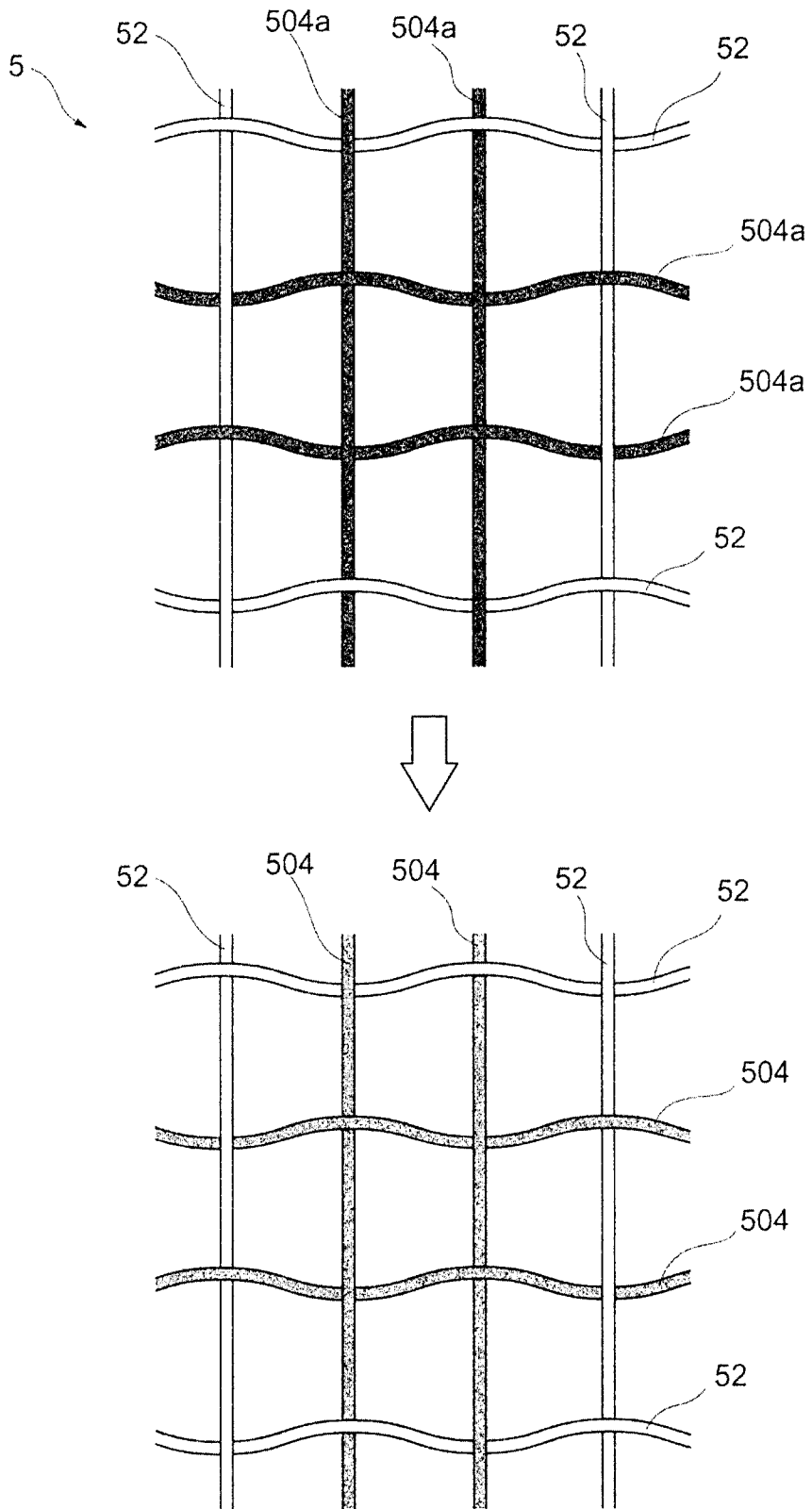

[Figure 20]

