

July 12, 1938.

M. WARE

2,123,347

INTERNAL COMBUSTION ENGINE

Filed March 11, 1935

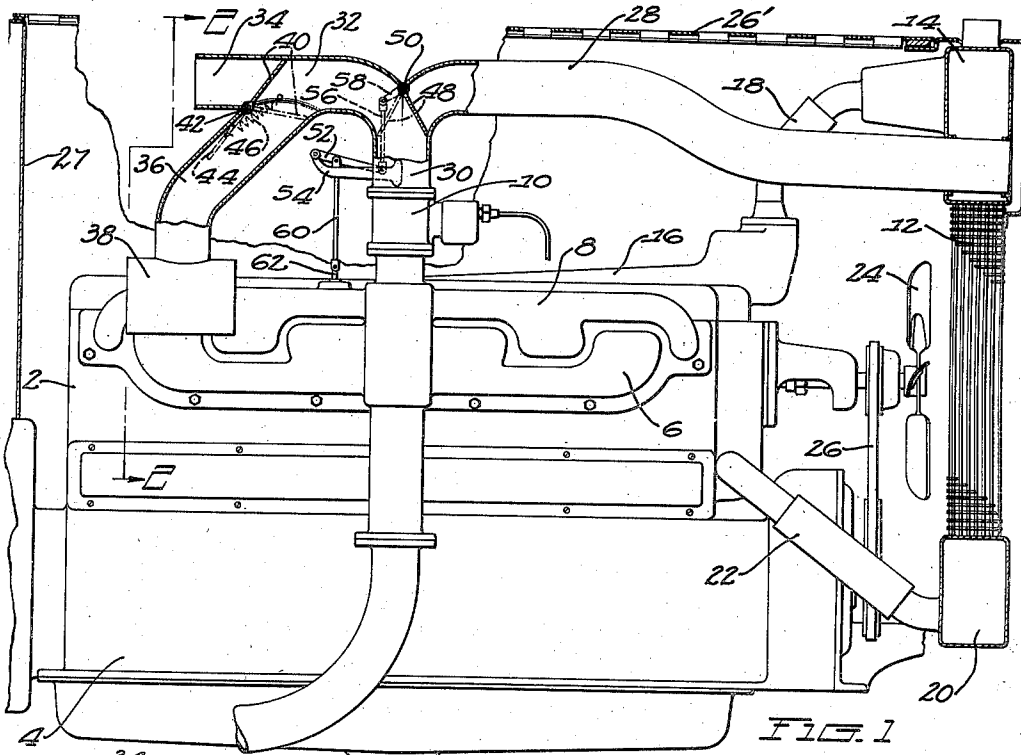

FIG. 1

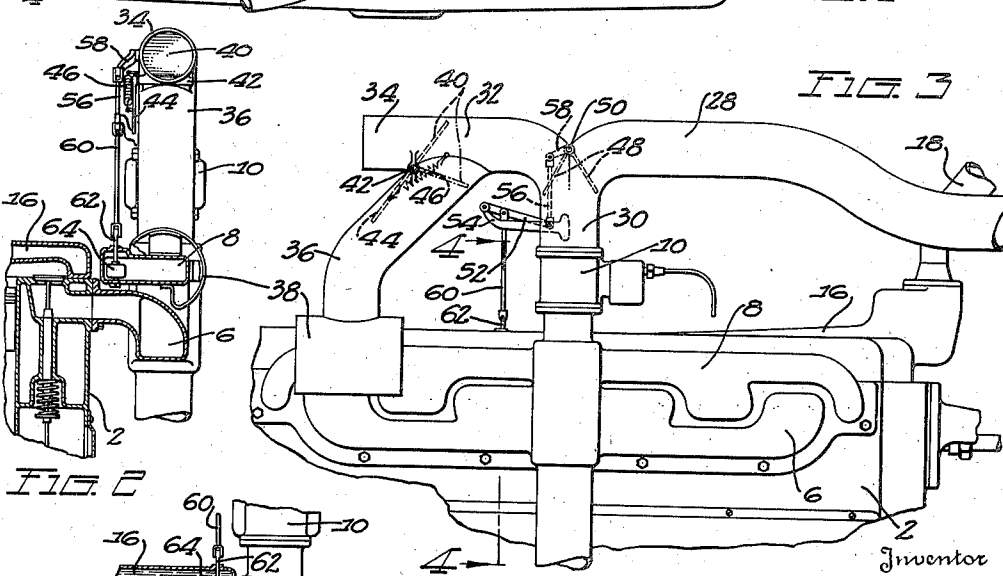

FIG. 2

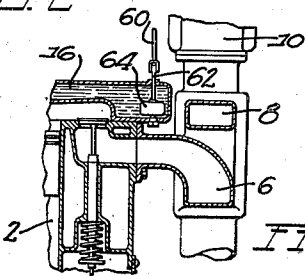

FIG. 3

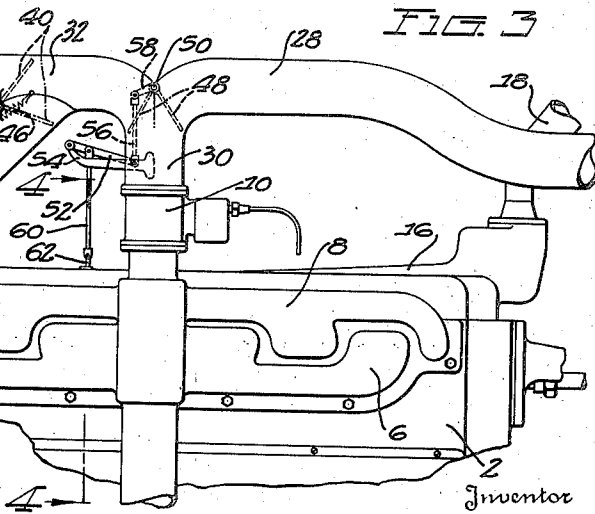

FIG. 4

MARSDEN WARE

Tibbells and Hart

Attorneys

# UNITED STATES PATENT OFFICE

2,123,347

## INTERNAL COMBUSTION ENGINE

Marsden Ware, Detroit, Mich., assignor to Packard Motor Car Company, Detroit, Mich., a corporation of Michigan

Application March 11, 1935, Serial No. 10,370

4 Claims. (Cl. 123—122)

This invention relates to internal combustion engines and more particularly to mechanism for controlling the temperature of the air supplied to the carburetors of such engines.

When an internal combustion engine is cold it is desirable to supply air heated above the temperature of the atmosphere to the carburetor in starting the engine in order to facilitate the vaporization of the fuel. When the engine is idling or is running at low speeds requiring a low power output and producing relatively low engine temperatures, it is desirable to supply heated air to the carburetor to form a mixture having a sufficiently high temperature to retain the fuel in vaporized condition and to ignite readily. When the engine is running at high speed thus producing high engine temperatures it is desirable to supply air at low temperatures to the carburetor to form a low temperature mixture since such a mixture will produce a high power output for a given volume introduced into the engine. Thus, in general, the temperature of the air delivered to the carburetor should be varied inversely as the temperature of the engine.

One object of the present invention is to produce a mechanism for controlling the temperature of the air supplied to the carburetor of an internal combustion engine by which the temperature of the air may be automatically varied inversely as the temperature of the engine.

In one form of the invention the means for delivering air to the carburetor comprises devices for delivering air heated above the temperature of the atmosphere to the carburetor and devices for delivering relatively cool air thereto and another object of the invention is to provide a mechanism which is controlled automatically in accordance with the temperature of the engine for controlling respectively the proportions of heated and cool air delivered to the carburetor.

With the above and other objects in view the invention consists in a construction embodying the novel and improved features hereinafter described and particularly pointed out in the claims the advantages of which will be readily understood and appreciated by those skilled in the art.

The various features of the invention will be clearly understood from the accompanying drawing illustrating the invention in its preferred form and the following detailed descriptions of the constructions therein shown.

In the drawing Fig. 1 is a view in side elevation, with certain parts shown in section, illus-

trating an internal combustion engine embodying the invention.

Fig. 2 is a detail sectional view taken substantially on the line 2—2 of Fig. 1 with certain parts broken away.

Fig. 3 is a view in side elevation illustrating a portion of an internal combustion engine embodying the invention and having a somewhat different construction and arrangement of certain of the parts for controlling the air supply for the carburetor and,

Fig. 4 is a detail sectional view taken substantially on the line 4—4 of Fig. 3.

The invention is illustrated in Figs. 1 to 4 inclusive of the drawing as embodied in an internal combustion engine comprising a cylinder block 2, a crank case 4, an intake manifold 6, an exhaust manifold 8 and a down-draft carburetor 10. The cooling system for the engine comprises a radiator 12 having an upper chamber 14 connected with the upper chamber 16 of the engine jacket by conduit means as indicated at 18, a lower chamber 20 connected with lower portion of the engine jacket by conduit means as indicated at 22 and a fan 24 driven through a belt 26 from the crank shaft of the engine. The engine is enclosed by a hood 28 extending between the radiator and the dash 27.

Cool air is supplied to the carburetor by means of a pipe 28, the forward end of which extends through the upper chamber 14 of the radiator to the outer or forward side thereof. The rear end of the pipe 28 is connected with the upper end of the air inlet pipe 30 of the carburetor. When the pipe 28 is open to the carburetor and the vehicle is moving forwardly, air is supplied through said pipe under the pressure produced by the forward movement of the vehicle.

Air heated above the temperature of the air outside the hood is delivered to the carburetor through a pipe 32 also connected with the pipe 30. Under certain conditions, as in warm weather, it is desirable to supply to the pipe 32 the air from within the hood which has been heated above the temperature of the outside air by its passage through the radiator and its contact with the heated parts of the engine. Under other conditions, as in cold weather, it is desirable to supply air to the pipe 32 at a temperature substantially higher than the air within the hood. The pipe 32 is provided with a branch pipe 34 which opens into the space within the hood, warm air from this space being supplied through said branch pipe. The pipe 32 is provided with a second longer branch pipe 36 the

lower end of which is connected with a heater or "stove" 38. This heater consists of a casing partially surrounding the exhaust manifold and having open ends for the passage of air from the space within the bonnet into said casing. The air delivered to the pipe 32 by the branch pipe 36, is heated by its passage through the heater 38 and is therefore at a temperature considerably higher than that of the air from within the hood.

In order to enable either the warm air from the pipe 34 or the air at a higher temperature from the pipe 36 to be delivered to the pipe 32, a damper valve 40 is pivoted by means of a pivot pin 42 at the juncture of the branch pipes 34 and 36 and is arranged to close alternatively the forward end of the pipe 34 as shown in full lines in Figure 1 or the upper end of the pipe as shown in dot-and-dash lines in said figure. To enable the valve to be located and held in either of the above described positions a rod 44 is secured to one end of the pivot pin 42 to which the valve is fixed and a coiled spring 46 is connected at one end to said rod and at the other to a stud fixed in the pipe 32. This spring is carried across the axis of the valve by the swinging movement thereof from one position to another and will act to hold the valve in either of its adjusted positions.

The proportions of the heated air delivered through the pipe 32 and the cool air delivered through the pipe 28 are controlled automatically to control the temperature of the air mixture entering the carburetor by means of a valve 48 pivoted by means of a pivot pin 50 at the juncture of the pipes 28 and 32. This valve is arranged to swing between the position shown in full lines in Fig. 1 in which it closes the pipe 28 and the position shown in dot-and-dash lines in said figure in which it closes the pipe 32. This valve may be located in any position between these two limiting positions. The position of the valve is controlled by the temperature within the engine. In the construction shown in Figs. 1 and 2 the mechanism for controlling the position of the valve comprises a lever 52 pivoted on a bracket 54 attached to the pipe 30 and a link 56 connecting one arm of said lever with an arm 58 attached to the pivot pin 50 to which said valve 48 is fixed. The lever is also connected by a link 60 with the upper end of a longitudinally movable rod 62 of a thermostat 64. This thermostat may have any suitable construction and is illustrated diagrammatically in the drawing.

In the construction shown in Figs. 1 and 2 the thermostat 64 is located within a portion of the exhaust manifold 8 so that it is constantly surrounded by the exhaust gases passing through said manifold. With this construction the thermostat is controlled to regulate the position of the valve 48 by the temperature of the exhaust gases flowing through the exhaust manifold.

The construction shown in Figs. 3 and 4 differs from that shown in Figs. 1 and 2 only in that the thermostat 64 in the former construction is located within the upper chamber 16 of the engine jacket through which the cooling fluid is circulated so that the position of the valve 48 is controlled by the temperature of the water or other cooling fluid circulating through the engine jacket.

By means of the construction above described the position of the valve 48 will be controlled by the temperature within the engine to cause the air to be supplied to the carburetor at a tem-

perature varying inversely as that of the engine. When the engine is cold the valve 48 will be located in the position shown in full lines in Fig. 1 so that heated air only will be drawn into the carburetor. Also when the engine is idling or is running at low speeds thereby producing low engine temperatures the valve 48 will be located so that the greater part of the air mixture supplied to the carburetor will consist of heated air drawn through the pipe 32. As the temperature of the engine increases the valve 48 will be gradually swung toward the dotted line position Figs. 1 and 3 by the action of the thermostat to cause a gradually increasing proportion of cool air to be drawn into the carburetor. When the engine is running at high speeds thereby producing high engine temperatures the valve 48 will be swung substantially into position shown in dot-and-dash lines in Fig. 1 so that cool air only will be supplied to the carburetor through the pipe 28. This cool air will produce a low temperature explosive mixture giving a high power output.

With the construction above described, the temperature of the air supplied to the carburetor is varied inversely as the temperature of the engine. When the engine is cool, heated air at the temperature of the air within the hood or air heated to a higher temperature is delivered to the carburetor to facilitate the vaporization of the fuel during the starting operation. During the running of the engine at low speeds producing relatively low engine temperatures a large proportion of heated air is supplied to the carburetor. As the temperature of the engine increases the proportion of heated air in the air mixture delivered to the carburetor is diminished and the proportion of unheated or relatively cool air in said mixture is increased to reduce the temperature of said mixture. At very high speeds producing correspondingly high engine temperatures relatively cool air only having a high oxygen content is delivered to the carburetor.

The temperature within the engine at which the valve 48 is located respectively to close the rear end of the pipe 28 so that only heated air is supplied to the carburetor and at which the valve is located to close the forward end of the pipe 32 so that only cool air is supplied to the carburetor may be varied by the setting of the thermostat 64.

The temperature of the exhaust gases passing through the exhaust manifold varies more widely than the temperature of the cooling fluid circulating through the cooling system under different conditions. The thermostat 64 is preferably located in the path of said gases since this produces a more sensitive mechanism for controlling the temperature of the air delivered to the carburetor.

It is to be understood that the invention is not limited to the particular construction of the illustrated embodiment of the invention but that the said construction is merely illustrative of the invention and that the invention may be embodied in other forms within the scope of the claims.

Having explained the nature and object of the invention and having specifically described a construction embodying the invention in its preferred form what is claimed is:

1. In an internal combustion engine, air feeding means for a carburetor comprising a main supply pipe leading to the carburetor, an inlet pipe leading to said main supply pipe and open

to atmosphere, another inlet pipe leading to said main supply pipe for supplying air having two relatively different ranges of temperature, valve means for controlling the relative proportions of air flowing from the two inlet pipes to the main supply pipe, and means responsive to the engine temperature for adjusting said valve means, said valve means regulating the proportion of air entering the main supply pipe from said inlet pipes to control the air temperature entering the carburetor inversely to the engine temperature variance.

2. In an internal combustion engine, air feeding means for a carburetor comprising a main supply pipe leading to the carburetor, an inlet pipe leading to said main supply pipe and open to unheated air in a forward direction, a second inlet pipe leading to said main supply pipe through which engine heated air flows to the main supply pipe in either one of two temperature ranges, a valve for regulating the air flowing from said inlet pipes to said main supply pipe, and means responsive to the engine temperature for adjusting said valve, said valve in its adjustment varying the temperature of the air entering the main supply pipe inversely to engine temperature variance.

3. In a motor vehicle having an engine enclosed by a hood, means for supplying fuel air to the engine comprising a carburetor intake conduit, a pair of main inlet conduits leading to the intake conduit, one of said main conduits opening to atmosphere exteriorly of the hood, the other of said main conduits being open at one end to the space within said hood, an air conduit leading to said last mentioned main conduit in which the temperature of air within the hood is raised, a valve operable to selectively close or open either source of heated air, and a valve in the junction portion of said main conduit adjustable to regulate the temperature of air entering the carburetor intake conduit.

4. In an internal combustion engine having a carburetor, of air feeding means for the carburetor comprising two devices for feeding the air to the carburetor at different temperatures above atmospheric temperature, means adjustable to selectively shut off either of said feeding devices, means for delivering unheated air to the carburetor and thermostatically controlled means for regulating the proportion of heated air and unheated air moving into the carburetor.

MARSDEN WARE.