

No. 640,152.

Patented Dec. 26, 1899.

J. G. VOSE.
NUT LOCK.

(Application filed Sept. 18, 1899.)

(No Model.)

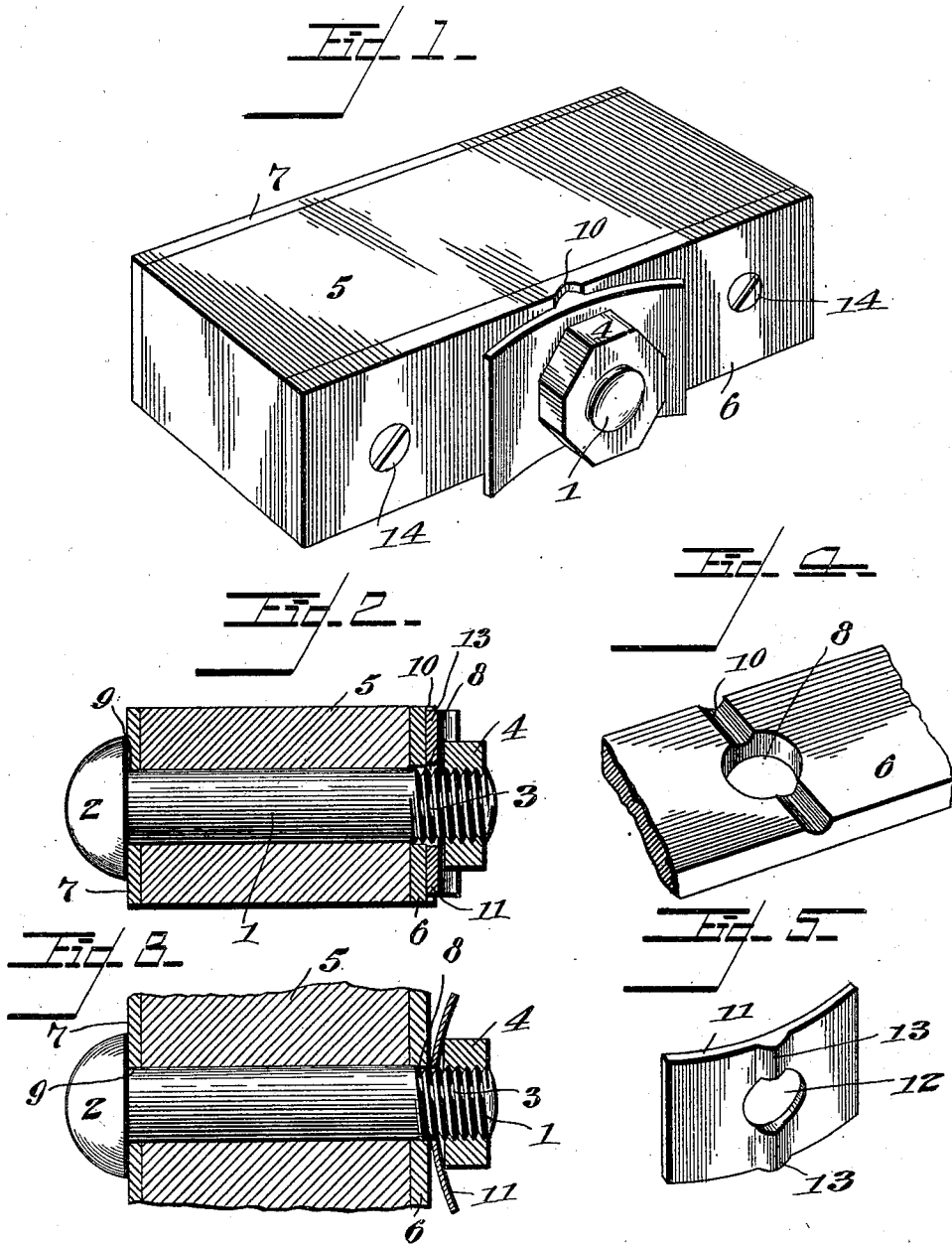

Witnesses

F. D. Amman
W. H. Shepard

By *two* Attorneys,

John G. Vose. Inventor
C. A. Snow & Co.

UNITED STATES PATENT OFFICE.

JOHN G. VOSE, OF LAWRENCEVILLE, GEORGIA, ASSIGNOR OF ONE-FOURTH
TO THOMAS ALLEN SMITH, OF SAME PLACE.

NUT-LOCK.

SPECIFICATION forming part of Letters Patent No. 640,152, dated December 26, 1899.

Application filed September 18, 1899. Serial No. 730,922. (No model.)

To all whom it may concern:

Be it known that I, JOHN G. VOSE, a citizen of the United States, residing at Lawrenceville, in the county of Gwinnett and State of Georgia, have invented a new and useful Nut-
Lock, of which the following is a specification.

This invention relates to nut-locks, and has for its object to provide an improved device of this character which will permit of the ready application and removal and also renewed use of the parts thereof without damage to the bolt or nut.

To this end the present improvement consists in the combination and arrangement of parts, as will be hereinafter more fully described, shown in the accompanying drawings, and particularly pointed out in the appended claim, it being understood that changes in the formation, proportion, size, and minor details may be made within the scope of the appended claim without departing from the spirit or sacrificing any of the advantages of the invention.

In the drawings, Figure 1 is a perspective view showing the application of the present invention. Fig. 2 is a sectional view taken longitudinally of the bolt. Fig. 3 is a similar view taken at right angles to Fig. 2. Fig. 4 is a detail perspective view of the base against which the nut is to be locked, and Fig. 5 is a detail perspective view of the locking-washer.

Corresponding parts in the several figures of the drawings are designated by like characters of reference.

Referring to the accompanying drawings, 1 designates a bolt provided at opposite ends with a head 2 and a threaded portion 3, to which latter portion is fitted a nut 4. These parts are of common or usual form and require no change or alteration whatsoever.

In Figs. 1, 2, and 3 I have illustrated the bolt as passing through a block of wood 5, the opposite faces of which are protected by wear-plates 6 and 7, each of which is provided with a bolt-opening 8 and 9, respectively. As best illustrated in Fig. 4, the wear-plate 6 at the threaded end of the bolt is provided with a transverse groove 10, which intersects the bolt-opening 8 and extends in diametrically

opposite directions and at opposite sides of said bolt-opening.

The locking-washer is shown in detail in Fig. 5 and comprises a bowed plate 11, having a central and unthreaded or smooth bolt-opening 12. Provided upon the convex side of the washer and alined diametrically at opposite sides of the bolt-opening 12 is a pair of lugs 13, which are alined parallel with the axis of the curvature of the washer.

In the application of the device the locking-washer is placed upon the projecting threaded end of the bolt with its convex side next the wear-plate 6 and the lugs 13 fitting within the groove 10, so that the washer is held against axial turning upon the bolt. The nut 4 is then screwed upon the threaded portion of the bolt and against the outer concave side of the washer. As clearly shown in Fig. 3, it will be seen that the opposite edges of the washer parallel with the lugs thereof overhang opposite edges of the nut, and as the latter is forced against the concave side of the washer these overhanging portions of the latter frictionally engage the edges of the nut, and thereby hold the latter against being accidentally turned in the opposite direction, and thereby prevent loosening of the nut. It will of course be understood that the nut may be unscrewed by the application of force, so that the nut may be removed without damage either to itself or the bolt.

The outer wear-plate 6 is fixed against turning by means of the screw-fastenings 14, to form a fixed washer-plate or base with which the spring-locker is interlocked by means of the groove 10 and the lugs 13. When the washer or nut is to be locked against a metallic surface, the wear-plate may be dispensed with and the groove 10 formed directly in such metallic surface, in which event the latter forms the fixed base against which the washer is locked.

Having thus described the invention, what is claimed, and desired to be secured by Letters Patent, is—

In a nut-lock, the combination with a bolt and a nut, of a fixed washer-plate having grooves or recesses in its outer face, and a

bowed spring-washer located between the nut
and the fixed washer, having its convex side
provided with lugs registering with the
grooves or recesses of the fixed washer, and
5 its concave side frictionally engaging the in-
ner edges of the nut.

In testimony that I claim the foregoing as

my own I have hereto affixed my signature in
the presence of two witnesses.

JOHN G. VOSE.

Witnesses:

T. A. SMITH,
JAKE PENTICOST.