

(19) World Intellectual Property
Organization
International Bureau



(43) International Publication Date
16 September 2004 (16.09.2004)

PCT

(10) International Publication Number
WO 2004/077951 A2

- (51) International Patent Classification⁷: **A21B**
- (21) International Application Number: PCT/US2004/005892
- (22) International Filing Date: 27 February 2004 (27.02.2004)
- (25) Filing Language: English
- (26) Publication Language: English
- (30) Priority Data:
60/451,380 28 February 2003 (28.02.2003) US
- (71) Applicant: **MODEC INTERNATIONAL, L.L.C.**
[US/US]; 1201 Dairy Ashford, Suite 100, Houston, TX 77079 (US).
- (72) Inventors: **WYBRO, Pieter, G.**; 106 Townsend Mill Court, Houston, TX 77094 (US). **WU, Shakai**; 22523 Holly Lake Drive, Houston, TX 77450 (US).
- (74) Agent: **BUSH, Gary, L.**; Andrews Kurth, LLP, 600 Travis, Suite 4200, Houston, TX 77002 (US).
- (81) Designated States (unless otherwise indicated, for every kind of national protection available): AE, AG, AL, AM, AT, AU, AZ, BA, BB, BG, BR, BW, BY, BZ, CA, CH, CN, CO, CR, CU, CZ, DE, DK, DM, DZ, EC, EE, EG, ES, FI, GB, GD, GE, GH, GM, HR, HU, ID, IL, IN, IS, JP, KE, KG, KP, KR, KZ, LC, LK, LR, LS, LT, LU, LV, MA, MD, MG, MK, MN, MW, MX, MZ, NA, NI, NO, NZ, OM, PG, PH, PL, PT, RO, RU, SC, SD, SE, SG, SK, SL, SY, TJ, TM, TN, TR, TT, TZ, UA, UG, US, UZ, VC, VN, YU, ZA, ZM, ZW.
- (84) Designated States (unless otherwise indicated, for every kind of regional protection available): ARIPO (BW, GH, GM, KE, LS, MW, MZ, SD, SL, SZ, TZ, UG, ZM, ZW), Eurasian (AM, AZ, BY, KG, KZ, MD, RU, TJ, TM), European (AT, BE, BG, CH, CY, CZ, DE, DK, EE, ES, FI, FR, GB, GR, HU, IE, IT, LU, MC, NL, PT, RO, SE, SI, SK,

[Continued on next page]

(54) Title: RISER PIPE SUPPORT SYSTEM AND METHOD

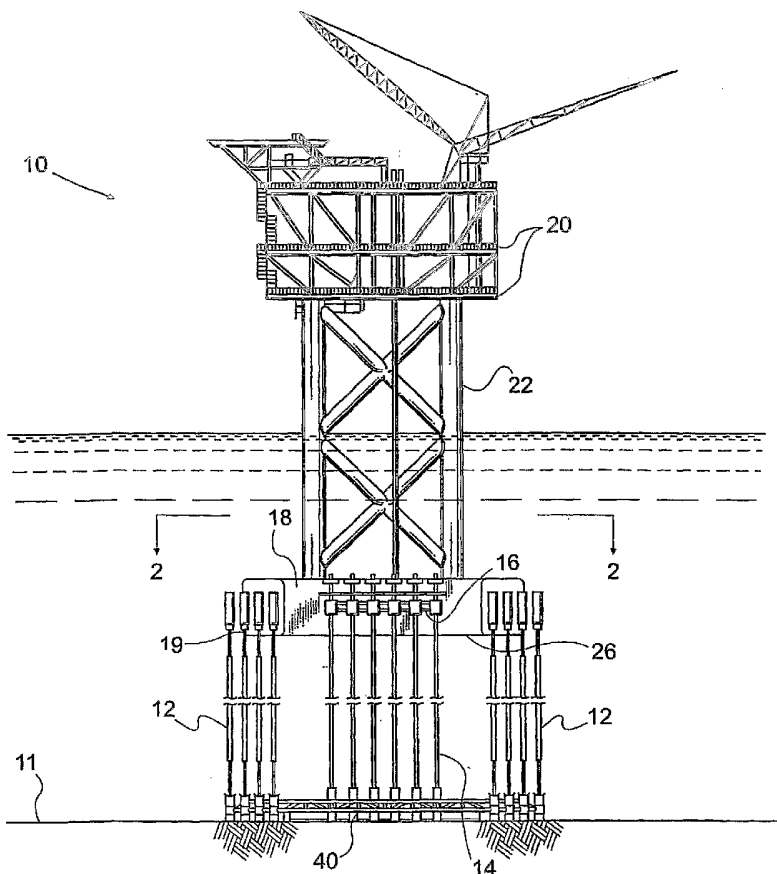

(57) Abstract: A system and method for mating risers or umbilicals extending vertically or near vertically from the ocean floor to a floating offshore system such as a TLP or semisubmersible platform. The risers or umbilicals are suspended vertically above the vessel's keel and are supported laterally near the platform's keel by keel guides or riser receptacles positioned along the submerged perimeter of the vessel's hull, or within the hull by production riser slots disposed in the bottom of the hull. The keel guides or production riser slots each receive a keel joint assembly which laterally supports a riser or umbilical passing therein while providing a bearing surface for free vertical movement of the riser.

WO 2004/077951 A2



TR), OAPI (BF, BJ, CF, CG, CI, CM, GA, GN, GQ, GW, ML, MR, NE, SN, TD, TG).

For two-letter codes and other abbreviations, refer to the "Guidance Notes on Codes and Abbreviations" appearing at the beginning of each regular issue of the PCT Gazette.

Published:

— *without international search report and to be republished upon receipt of that report*

RISER PIPE SUPPORT SYSTEM AND METHOD

BACKGROUND OF THE INVENTION

1. Field of the Invention

5 The present invention relates generally to offshore hydrocarbon production and more particularly to fixing a keel guide on the submerged perimeter of the hull of a tension leg platform or other floating offshore vessel to laterally support a riser or umbilical extending vertically or near vertically from the seabed.

10 2. Description of the Prior Art

In the offshore drilling and production industry, signals, control fluids or chemicals are injected from the surface to the ocean-bottom wells in umbilicals, and hydrocarbons are transported from the subsea wells to the floating production platform or vessel in risers. A riser pipe is used to connect a subsea wellhead structure at the sea floor with the hydrocarbon processing system located on a floating platform maintained in position above the wellhead. The lower ends of the risers are connected to the sea floor by structures embedded in the sea floor and grouted or cemented thereto. For a floating structure such as a tension leg platform (TLP) or a semi-submersible platform, the riser is typically suspended from the floating vessel using a support platform.

20 As shown in Figures 1 and 2, a typical TLP (10) consists of one or more decks (20) with equipment for production and processing of hydrocarbons. The deck (20) is supported by a hull (18), which is submerged or partially submerged and which provides the buoyant force for the platform. The hull (18) provides attachment points (19) for tendons (12) anchored to the seabed (11). The hull (18) may comprise one or more

submerged pontoons, often positioned to form a horizontal triangle, square or circle, or as illustrated in Figures 1 and 2, a cruciform structure. One or more vertical columns (22) extend from the hull (18) upwards through the water's surface and attach to the deck (20).

Risers (14) or umbilicals extend from subsea wells (40) to the platform (10). The risers (14) are traditionally vertically suspended and laterally supported below the water's surface by a structure (16) attached to the platform (10). Risers are traditionally spaced apart from the hull to minimize impact with the hull caused by environmental forces and to allow easier termination of the risers. For example, Figures 1-2 disclose a moored TLP of prior art with risers (14) vertically suspended and laterally supported under water by a truss extending outboard from the hull.

Alternatively, Figures 3 and 4 show a prior art TLP (10) moored by tendons (12) connected to the hull (18) at attachment points (19). The TLP (10) has columns (22) supporting a superstructure with decks (20). As illustrated in Figure 4, this TLP hull (18) is configured with pontoons forming a square within a cruciform shape. A rectangular array of risers (14) passes through the center of the platform (10), suspended below the water's surface and laterally braced interiorly away from the hull by a grid-like network of struts (16). U.S. 6,273,018 shows a buoyant offshore platform using a similar arrangement of risers passing through the center of the platform and supported by trusses.

For floating offshore structures, the design of the interface between the riser and the offshore structure must take into account the loads and relative motions as well as the resulting stresses and fatigue that the riser and interface must endure. Floating offshore vessels have structures which extend well below the surface of the water and which are subjected to environmental forces resulting in movement of the platform. Both the upper

and lower ends of the risers are affected by movement of a floating platform. Forces acting on a floating vessel and riser pipe system include forces resulting from heave, pitch, roll, sway or surge, height and period of waves and swells, currents, specific gravity of fluid conducted within the riser, buoyancy means attached to the riser, current profile, offset of the platform from the well, tension at the top of the riser, the stiffness of the riser, and the riser's vertical disposition.

Environmental forces can produce lateral movement of the platform with respect to the wellhead, which causes platform set-down – the difference between the vertical elevation at the no-load position above the wellhead and the vertical elevation when laterally displaced by environmental forces. In other words, a lateral displacement increases platform draft due to tendon restraint. Platform set-down produces a change in riser tension and, unless a riser is located coaxially with a mooring tendon, a change in the effective length of the riser. Thus, during platform set-down, there is a vertical sliding movement between the upper ends of the risers and the platform. This relative vertical movement is known as riser stroke.

Because of the generally parallel relationship between the risers or umbilicals and the mooring tendons, riser stroke is also a function of platform design. Locating risers close to the hull reduces potential riser stroke, while locating risers further away from the hull increases potential riser stroke. To compensate for riser stroke, the upper ends of risers are connected to the platform by relatively complex riser tensioning systems which permit the platform to move relative to the riser and at the same time maintain a desired tension on the riser.

It is advantageous to place risers close to the vessel hull to provide increased and simplified lateral support to the risers or umbilicals without an extensive network of struts. Further, placing the risers close to the hull results in reduced riser loads and reduced riser stroke for a given horizontal platform displacement, which allows more relaxed riser tensioner design requirements with a concomitant cost savings. A reduction in tensioner size and capacity requirements may also reduce deck loading and deck structural support requirements.

3: **Identification of Objects of the Invention**

The primary object of the invention is provide a floating platform designed to have risers or umbilicals that are vertically or near vertically suspended above the keel of the floating platform and that are laterally supported by keel guides positioned along the perimeter of the platform's hull at an elevation at or near the keel.

Another object of the invention is to provide lateral support to risers or umbilicals at a vertical elevation at or near the keel or the vertical elevation of the hull attachment point for mooring tendons.

Another object of the invention is to provide increased riser structural support, with a lateral support structure integral to or rigidly connected with the hull.

Another object of the invention is to provide a method to reduce the impact of wave action on the risers or umbilicals in the wave zone, minimizing riser/hull clashing and increasing riser fatigue life while allowing the risers to be arranged vertically or near vertically close to the hull.

Another object of the invention is to provide a method of reducing potential riser stroke by arranging risers vertically close to the hull.

Another object of the invention is to provide a method of reducing riser tensioner capacity and other design requirements by reducing potential riser stroke.

SUMMARY OF THE INVENTION

The objects identified above, as well as other features and advantages of the invention are incorporated in a floating offshore system, such as a TLP or semi-submersible platform, which mates with risers or umbilicals extending vertically or near vertically from the ocean floor. The risers are suspended vertically from above the keel (and usually, but not necessarily, above the water's surface) and are supported laterally at or near the hull by keel guides positioned along the submerged perimeter of the platform's hull, or within the hull by production riser slots. The keel guides or production riser slots are designed and arranged to receive a keel joint which provides a bearing surface to laterally support the riser while allowing free vertical movement relative to the platform. The keel guides may be positioned on outboard-facing hull surfaces, inboard-facing hull surfaces, or within a moonpool.

15 BRIEF DESCRIPTION OF THE DRAWINGS

The invention is described in detail hereinafter on the basis of the embodiments represented in the accompanying figures, in which:

Figure 1 illustrates a side view of a moored TLP of prior art having risers suspended under water from truss extending outboard from the hull;

20 Figure 2 is a cross section taken along lines 2-2 of Figure 1;

Figure 3 illustrates a side view of a moored TLP of prior art having risers suspended under water using a grid network attached to the interior sides of the TLP pontoons;

Figure 4 is a cross section taken along lines 4-4 of Figure 3;

Figure 5 is side view of a moored TLP according to the invention having risers vertically suspended from above the waterline and laterally supported below the waterline adjacent to and outboard of the TLP hull using keel guides;

5 Figure 6 is a cross section taken along lines 6-6 of Figure 5 showing risers laterally supported near the keel using keel guides attached to the outboard hull surfaces according to the invention;

Figure 7 is an enlarged side view of a portion of Figure 5 showing detail of the keel guides;

10 Figure 8 is a perspective view of an open frame side-entry keel guide according to the invention;

Figure 9 is a cross section of a typical keel joint or prior art;

Figure 10 is a vertical cross section of a TLP according to the invention showing a riser tensioner located on a platform deck;

15 Figure 11 is a horizontal cross section of a TLP according to the invention having risers laterally supported near the keel using keel guides attached to the inboard pontoon surfaces;

Figure 12 is a horizontal cross section of a TLP according to the invention having a moonpool with keel guides disposed therein; and

20 Figure 13 is a horizontal cross section of a TLP according to the invention having riser production slots in the bottom of the TLP hull.

DESCRIPTION OF THE PREFERRED EMBODIMENT OF THE INVENTION

Referring to Figures 5 and 6, this invention concerns a floating offshore system, such as a TLP or semi-submersible platform, hereinafter referred to simply as platform 10.

5 The platform consists of one or more decks 20 with equipment for production and processing of hydrocarbons, drilling, and workover. The deck 20 provides utility, safety, and supporting structures for human use. The deck 20 is supported by a hull 18 which is submerged or partially submerged and which provides the buoyant force for the platform. The hull 18 provides attachment points 19 for tendons 12 or other means of mooring. The
10 hull 18 may include one or more submerged pontoons, often positioned to form a horizontal triangle, square, circle, or cruciform-shaped structure. One or more vertical columns 22 extend from the hull 18 upwards through the water's surface and attach to the deck 20.

The platform 10 mates with one or more risers 14 or umbilicals extending
15 vertically or near vertically from the ocean floor 11. The risers 14 are used for drilling, production, export, or injection of water, gas or chemicals. The risers 14 according to the invention are vertically suspended above the keel 26, preferably from the deck 20. The platform 10 includes keel guides 7, also known as keel joint receptacles or support receptacles, which are positioned along the exterior submerged perimeter of the hull 18
20 and which simply provide lateral support to the risers 14. While keel guides 7 may be positioned at an elevated position on the hull 18, the keel guides 7 are preferably located at or near the vertical elevation of the keel 26 and/or the vertical elevation of the hull tendon attachment points (tendon porches). It is desirable, particularly in the case of TLPs, for the vertical elevation of the keel guides 7 to be kept at or close to that of the tendon

porches so that the top of the risers at the keel guide level moves in parallel with the top of the tendons.

Each riser 14 is equipped with a keel joint assembly 8 which is received into a keel guide 7. The keel joint 8 provides a bearing surface for riser 14, allowing the riser to
5 freely move along its vertical axis within the keel guide 7 while being supported laterally. Figure 7 is an enlarged view of the six keel guides illustrated in Figure 5 which provides greater detail of the structure of the keel guides but which shows only one riser 14 and keel joint 8.

Keel guide 7 is a structure integral with the hull 18 or designed and arranged for
10 rigid mounting to the vessel hull 18. Keel guide 7 is designed to receive particular riser keel joint 8. The keel guide 7 provides lateral support to a keel joint 8 and riser 14 within it. A keel guide can be of a slotted design 7A for side entry of the riser pipe or closed design 7B for vertical riser entry. A perspective sketch of a typical open frame side entry keel guide structure is shown in Figure 8.

15 Keel joints are known in the art, and Figure 9 illustrates detail of an ordinary keel joint 8 of prior art. Riser 14 is fitted with a keel joint outer casing 60 and elastomeric bearings 62. Bearings 62 are held in place by capture rings 64. A keel joint bushing 66 is fitted on the lower end of the outer casing 60. The keel joint 8 is then lowered into the keel guide 7, with the keel joint bushing 66 providing a secure fit within receptacle 7.
20 Alternate keel joints may be used, such as split joints, those with variable stiffness elements, or those with integral transitions from heavy wall riser pipe to normal riser O.D. pipe.

Figure 10 illustrates a production riser system according to the invention. Riser 14 is shown connected to a subsea wellhead 40 at the ocean floor 11. In order to compensate for riser stroke caused by environmental forces on the riser 14 and the platform 10, the riser 14 is tensioned from deck 20 by a passive spring riser tensioner 42. Preferably, the tensioner 42 is located on the cellar deck of platform 10. Riser 14 is laterally supported by a keel guide 7 attached to the platform hull 18 and keel joint 8 which is received in the keel guide 7. The riser 14 terminates at a tubing head 44 and surface tree 46, with an injection umbilical 48 and a production umbilical 50 extending therefrom.

According to the invention, keel guides may be placed anywhere along the hull 18 perimeter, including both outboard exterior surfaces 30 as illustrated in Figure 6, and inboard exterior surfaces 32 as illustrated in Figure 11. Figure 11 is a horizontal cross section of a TLP with a hull 18 formed by a ring shaped pontoon. Keel guides 7 are attached directly to the hull on the inboard surfaces 32 for laterally supporting risers 14. Although not shown in Figure 11, keel guides can simultaneously exist on both inboard surfaces 32 and outboard surfaces 30.

As illustrated in Figure 12, the hull 18 may include one or more moonpools 24. A moonpool is an opening in or near the center of the hull 18 or a closure of some space around the hull 18 that is used to route and protect the risers 14, among other functions. An open moonpool is one whose top and bottom are perforated to allow the routing of risers, and whose bottom and top are both below the water's surface. A closed moonpool, on the other hand, has a bottom located below the waterline and a top located above the waterline. Keel guides 7 may also be positioned within an either an open moonpool or a closed moonpool.

The present invention provides an alternate structure for laterally supporting a riser. Production riser slots or hawser pipe penetrations 6, positioned in the hull as shown in Figure 13, may be used. Like the earlier described configurations of the invention, the risers may be vertically supported by a tensioner located on deck 20, and keel joints are
5 designed and arranged to fit within the production riser slots 6.

Although this invention is best suited for support of risers during platform operation, it may be used for temporary support of the risers as well.

While the preferred embodiments of the invention have been illustrated in detail, it is apparent that modifications and adaptations of the preferred embodiments will occur to
10 those skilled in the art. Such modifications and adaptations are in the spirit and scope of the invention as set forth in the following claims:

WHAT IS CLAIMED IS:

1. A method for coupling a plurality of risers or umbilicals having lower ends fixed to an area of the sea floor to a floating vessel having a hull with a keel and moored generally above said area, the method comprising the steps of,

suspending said risers or umbilicals from an elevation above said keel, and

laterally supporting said risers at points along the perimeter of said hull.
2. The method of claim 1 wherein,

said points are disposed below the waterline.
3. The method of claim 1 wherein,

said points are disposed at an elevation generally corresponding to the elevation of said keel.
4. The method of claim 1 wherein,

said points are disposed on outboard-facing surfaces of said hull.
5. The method of claim 1 wherein,

said points are disposed on inboard-facing surfaces of said hull.
6. The method of claim 1 wherein,

said points are disposed on surfaces of a moonpool in said vessel.
7. The method of claim 1 further comprising the step of,

providing a bearing at each of said points, said bearing designed and arranged to allow axial movement of said riser relative to said vessel.
8. The method of claim 1 wherein,

said supporting is performed by a plurality of keel guides disposed at said points.

9. The method of claim 8 wherein,
at least one of said keel guides is designed and arranged to allow side entry of one of said risers.
10. The method of claim 8 wherein,
at least one of said keel guides is designed and arranged for vertical entry of one of said risers or umbilicals.
11. The method of claim 1 wherein said suspending further comprises the steps of,
tensioning said risers or umbilicals, and
allowing said risers or umbilicals to move axially with respect to said vessel.
12. The method of claim 1 further comprising the step of,
suspending said risers or umbilicals with a generally vertical orientation.
13. The method of claim 1 further comprising the step of,
suspending said risers or umbilicals from an elevation above the waterline.
14. The method of claim 1 wherein,
said suspending is performed by a spring.
15. The method of claim 1 wherein,
said suspending is performed by buoyancy of said vessel.
16. A method for coupling a plurality of risers or umbilicals having lower ends fixed to an area of the sea floor to a floating vessel having a submerged hull with a keel and moored generally above said area, the method comprising the steps of,
suspending said risers or umbilicals from an elevation above said keel, and
laterally supporting said risers or umbilicals in vertical passages formed through said hull.

17. The method of claim 16 further comprising the step of,
providing a bearing in each of said passages, said bearing designed and arranged to allow axial movement of said riser relative to said vessel.
18. The method of claim 16 wherein said suspending further comprises the steps of,
tensioning said risers or umbilicals, and
allowing said risers or umbilicals to move axially with respect to said vessel.
19. The method of claim 16 further comprising the step of,
suspending said risers or umbilicals with a generally vertical orientation.
20. The method of claim 16 further comprising the step of,
suspending said risers or umbilicals from an elevation above the waterline.
21. The method of claim 16 wherein,
said suspending is performed by a spring.
22. The method of claim 16 wherein,
said suspending is performed by buoyancy of said vessel.
23. A floating vessel comprising,
a submerged buoyant hull having a keel,
a column having a lower end coupled to said hull, said column extending above the waterline,
a deck coupled to an upper end of said column,
a mooring device having an upper end coupled to said hull and a lower end coupled to the seabed,
a keel guide having a vertically oriented generally cylindrical passage therein coupled to said hull, and

a riser or umbilical having a lower end coupled to the seabed and an upper end coupled to said vessel, said riser or umbilical passing within said passage of said keel guide.

24. The vessel of claim 23 wherein, said mooring device is generally vertically oriented and tensioned by said buoyant hull.

25. The vessel of claim 23 wherein, said riser or umbilical is generally vertically oriented and tensioned by said buoyant hull.

26. The vessel of claim 23 further comprising, a keel joint disposed between said riser or umbilical and said keel guide, said keel joint designed and arranged to provide lateral support to said riser or umbilical while allowing said riser or umbilical to move in a longitudinal direction within said keel guide.

27. The vessel of claim 23 wherein, said keel guide is disposed at an outboard-facing surface of said hull.

28. The vessel of claim 23 wherein, said keel guide is disposed at an inboard-facing surface of said hull.

29. The vessel of claim 23 wherein, said keel guide is disposed in a moonpool in said hull.

30. The vessel of claim 23 wherein, said keel guide has a slot which communicates with said passage and which is designed and arranged to allow side entry of said riser or umbilical.

31. The vessel of claim 23 wherein,
said keel guide is disposed at an elevation generally corresponding to the elevation of said keel.
32. The vessel of claim 23 wherein,
said keel guide is disposed at an elevation generally corresponding to the elevation of said upper end of said mooring device.
33. The vessel of claim 23 further comprising,
a tensioner coupled to said vessel and disposed at an elevation above said keel,
said upper end of said riser or umbilical coupled to said tensioner.
34. The vessel of claim 33 wherein,
said tensioner is disposed above the waterline.
35. The vessel of claim 33 wherein,
said tensioner is disposed on said deck.
36. A floating vessel comprising,
a submerged buoyant hull having a keel,
a column having a lower end coupled to said hull, said column extending above the waterline,
a deck coupled to an upper end of said column,
a mooring device having an upper end coupled to said hull and a lower end coupled to the seabed,
an aperture vertically formed through said hull, and

a riser or umbilical having a lower end coupled to the seabed and an upper end coupled to said vessel, said riser or umbilical passing within said passage of said keel guide.

37. The vessel of claim 36 wherein,
said mooring device is generally vertically oriented and tensioned said buoyant hull.

38. The vessel of claim 36 wherein,
said riser or umbilical is generally vertically oriented and tensioned by said buoyant hull.

39. The vessel of claim 36 further comprising,
a keel joint disposed between said riser or umbilical and said aperture, said keel joint designed and arranged to provide lateral support to said riser or umbilical while allowing said riser or umbilical to move in a longitudinal direction within said aperture.

40. The vessel of claim 36 further comprising,
a tensioner coupled to said vessel and disposed at an elevation above said keel, said upper end of said riser or umbilical coupled to said tensioner.

41. The vessel of claim 40 wherein,
said tensioner is disposed above the waterline.

42. The vessel of claim 40 wherein,
said tensioner is disposed on said deck.

43. The vessel of claim 40 wherein,
said riser or umbilical is generally vertically oriented and tensioned by said tensioner.

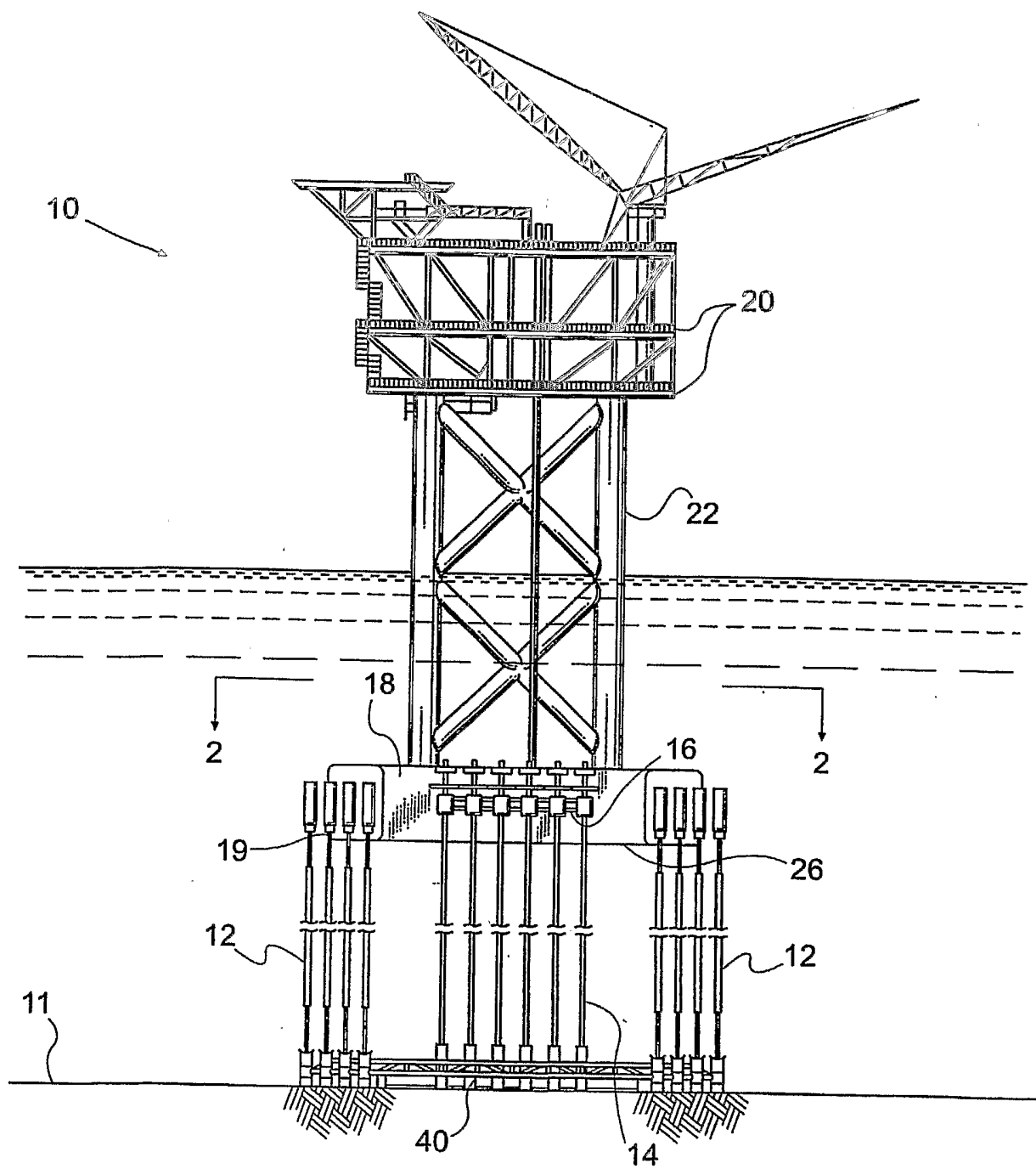

Fig. 1
(Prior Art)

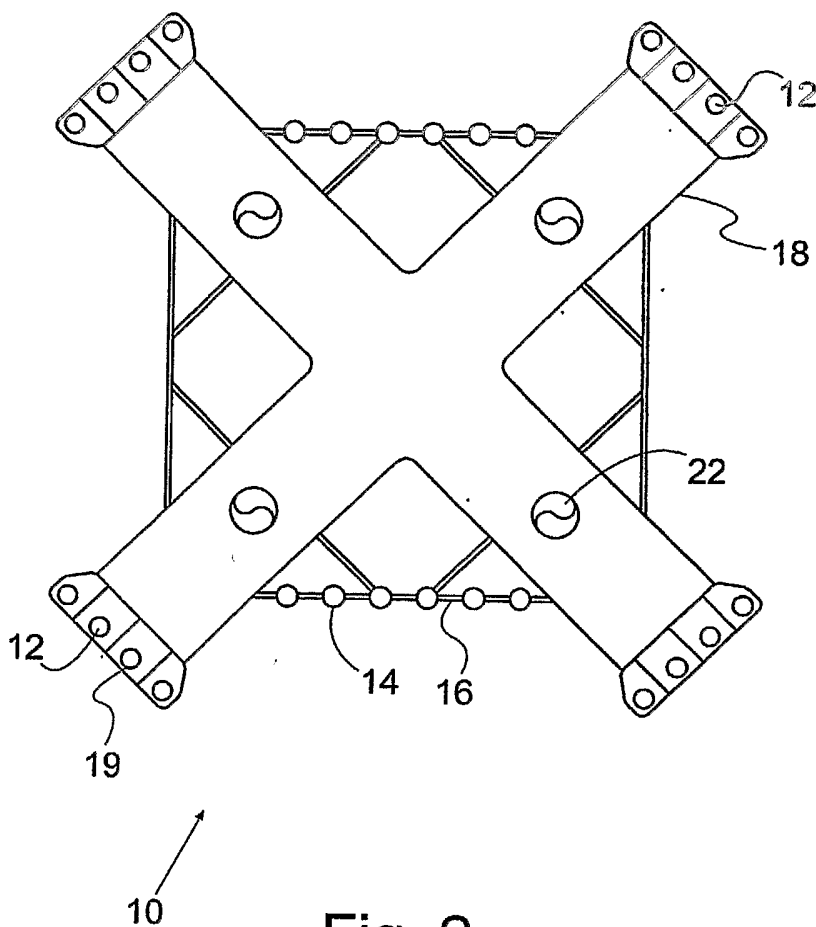

Fig. 2
(Prior Art)

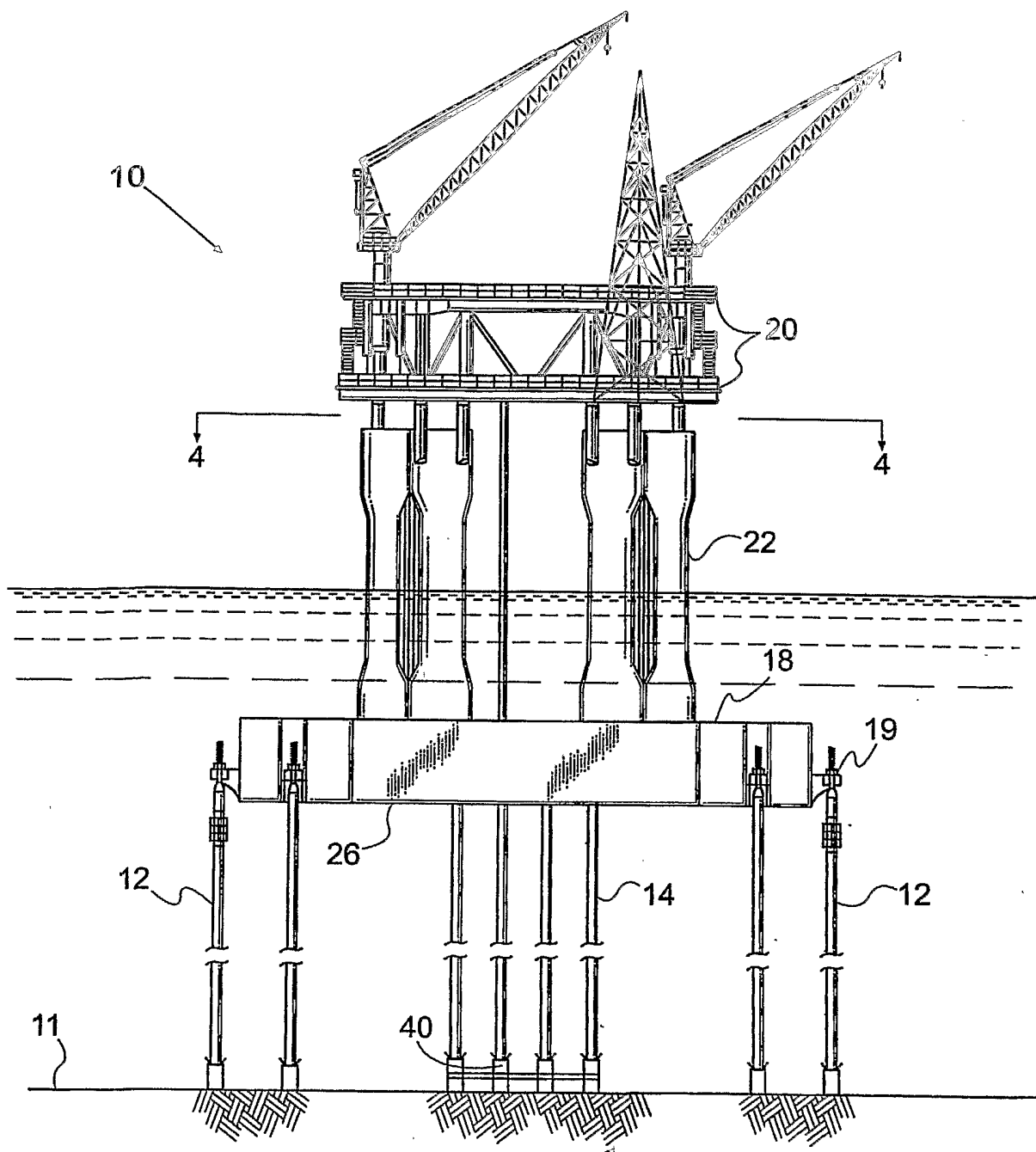

Fig. 3
(Prior Art)

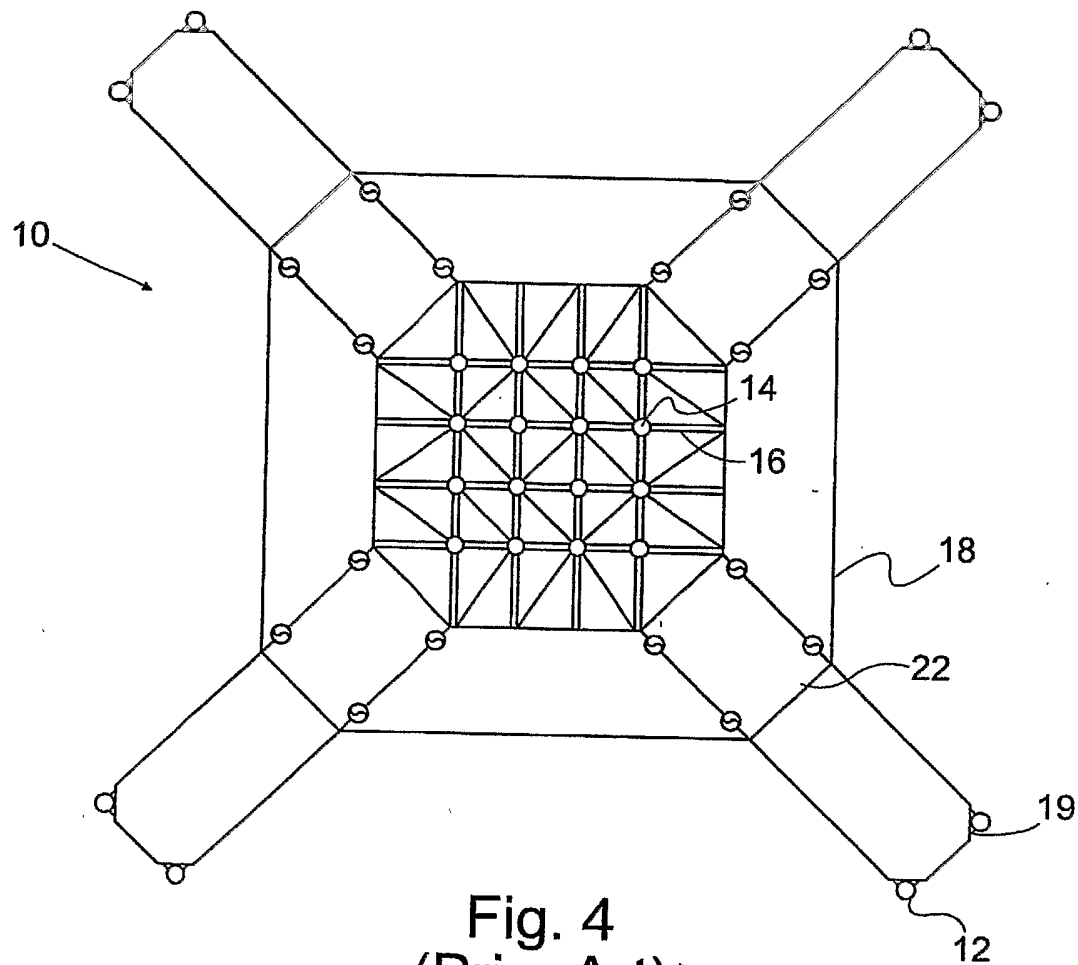

Fig. 4
(Prior Art)

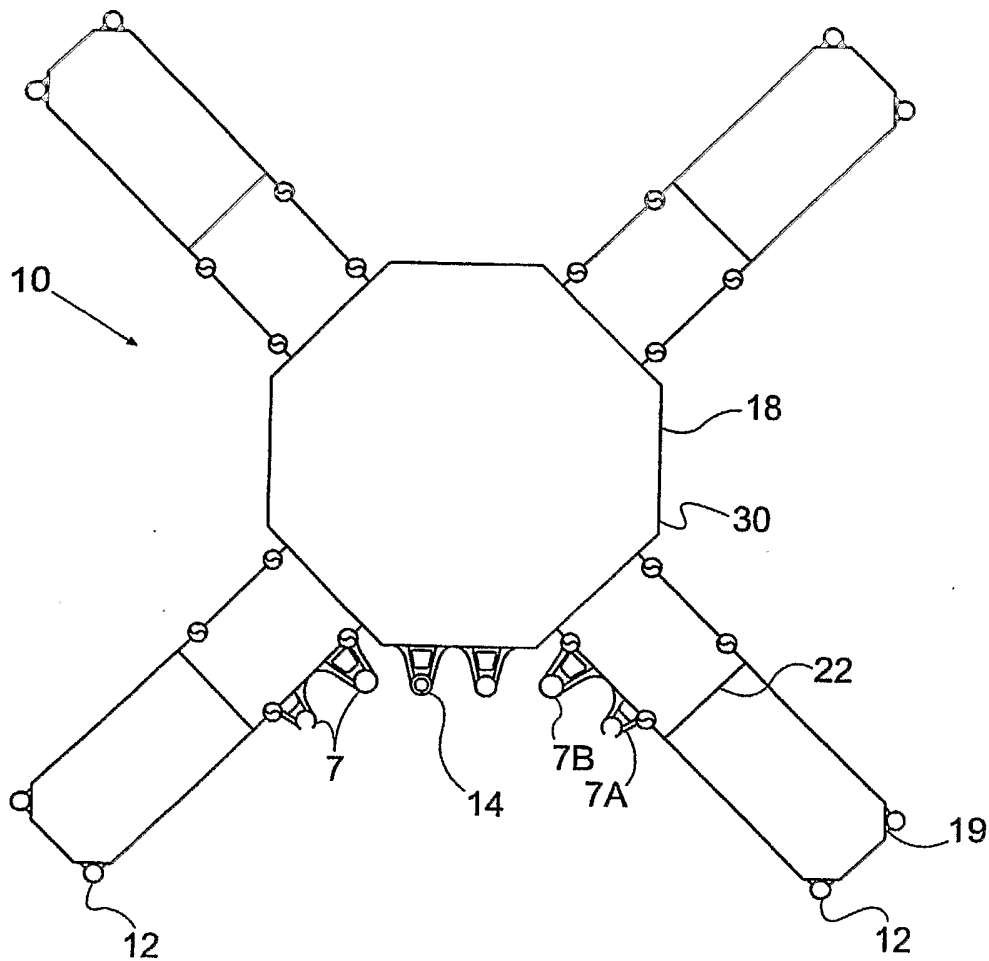

Fig. 6

7/12

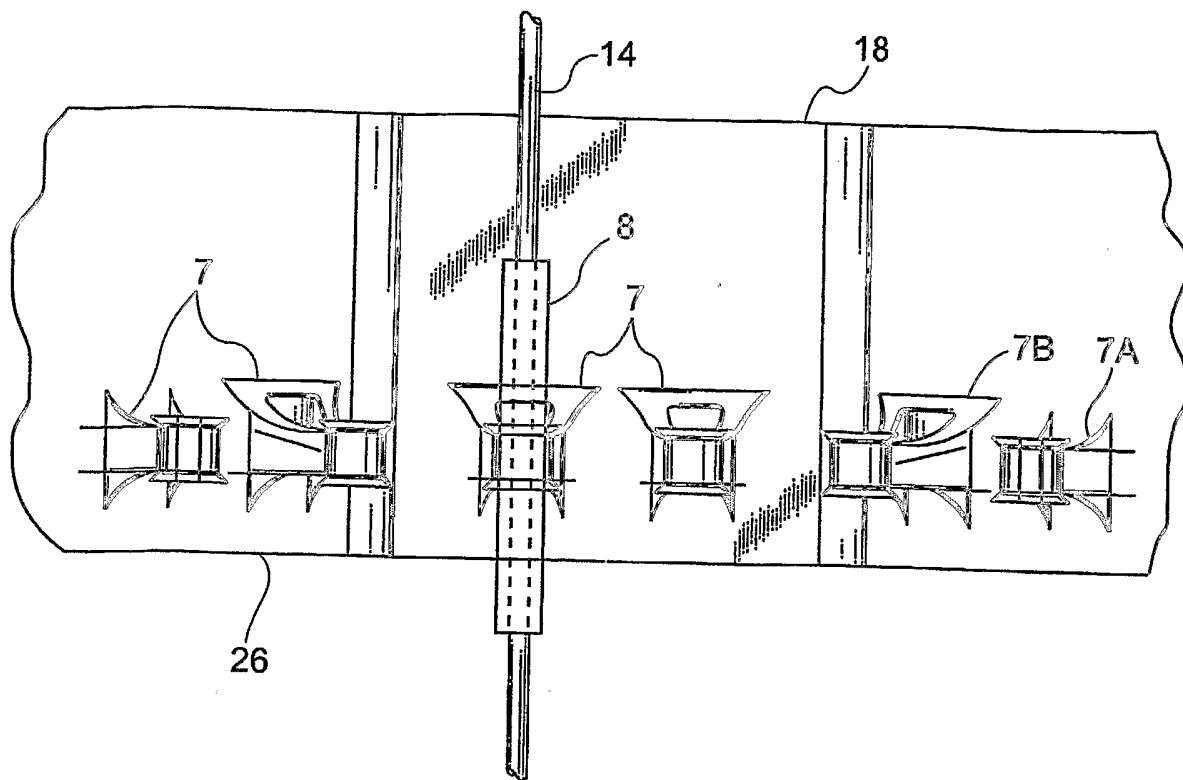

Fig. 7

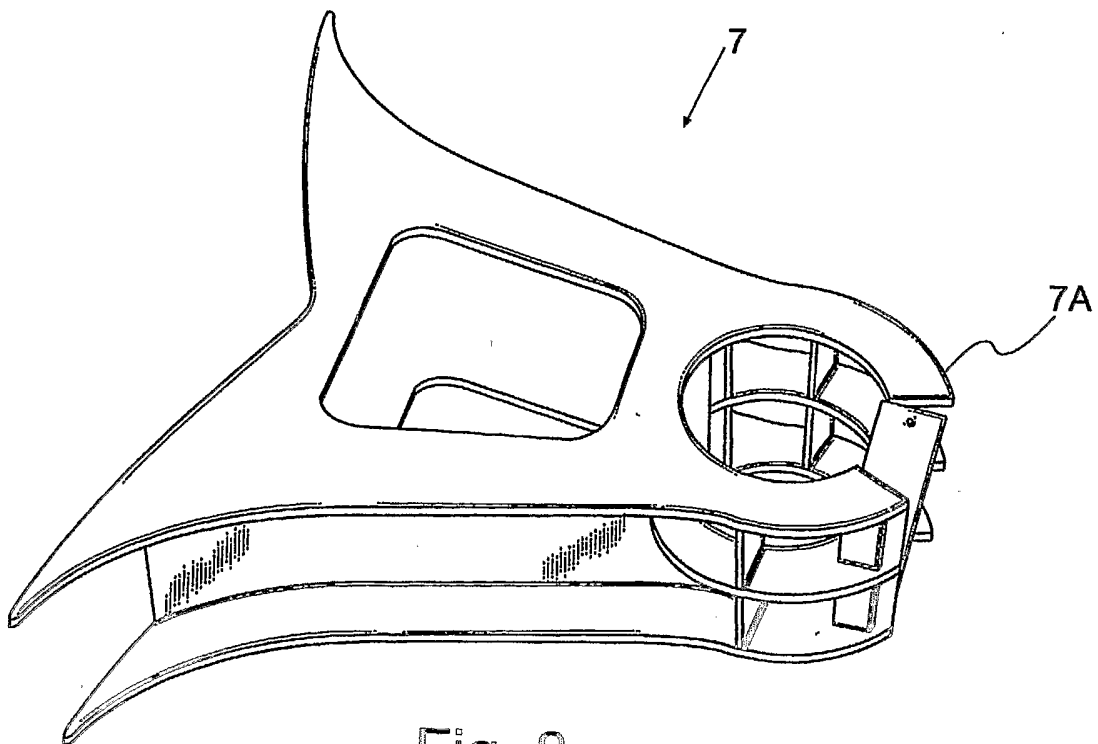

Fig. 8

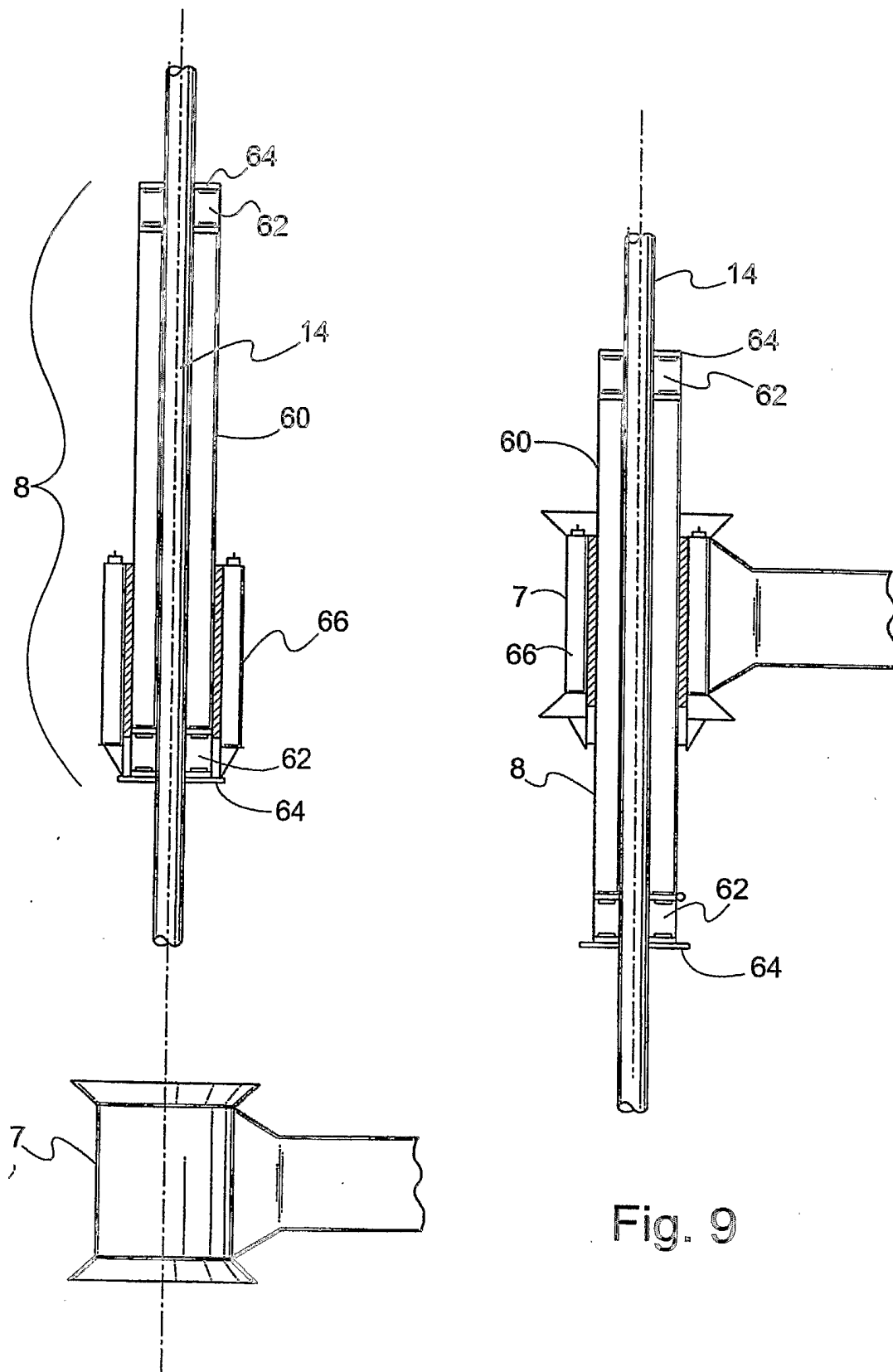

Fig. 9

9/12

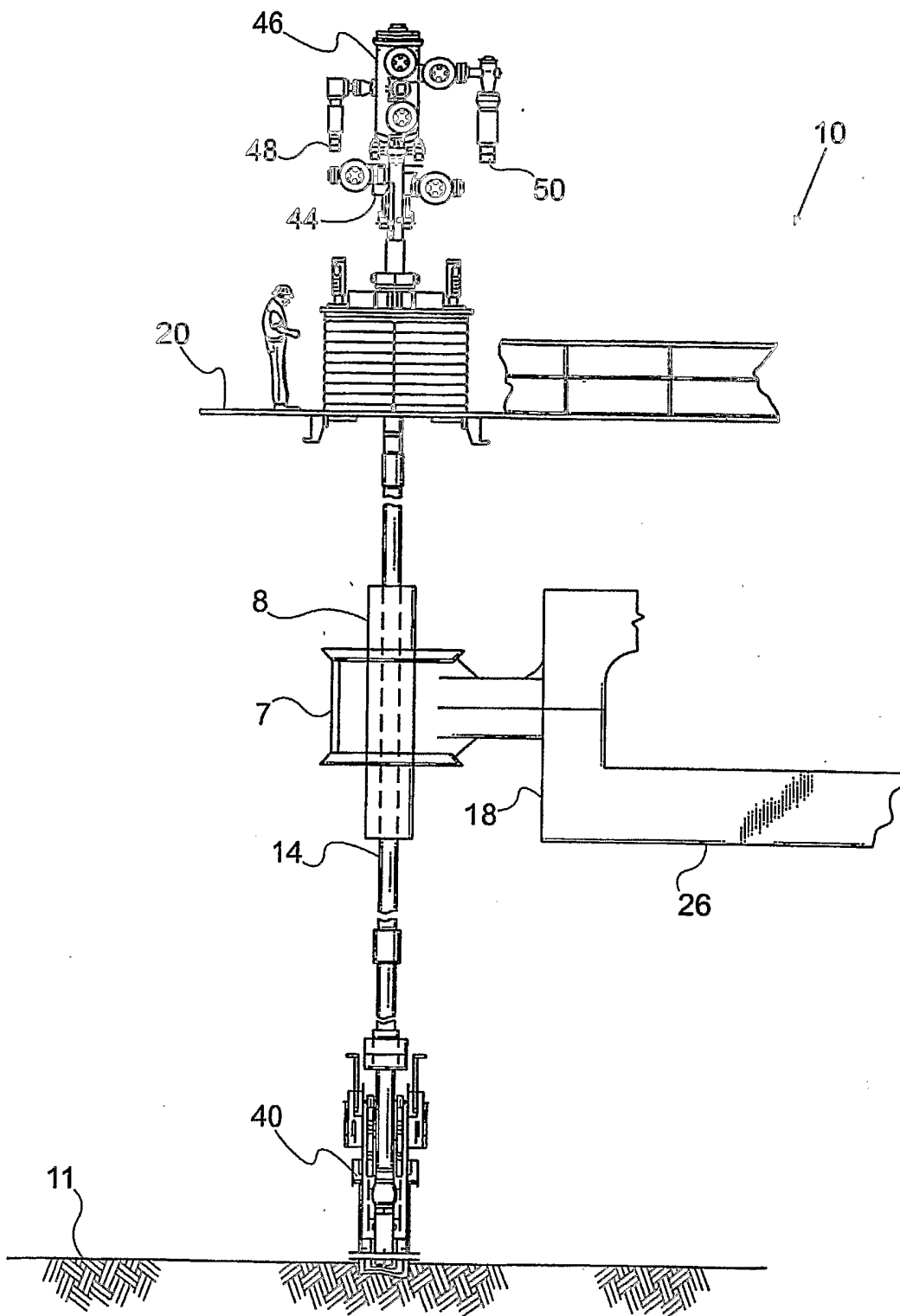

Fig. 10

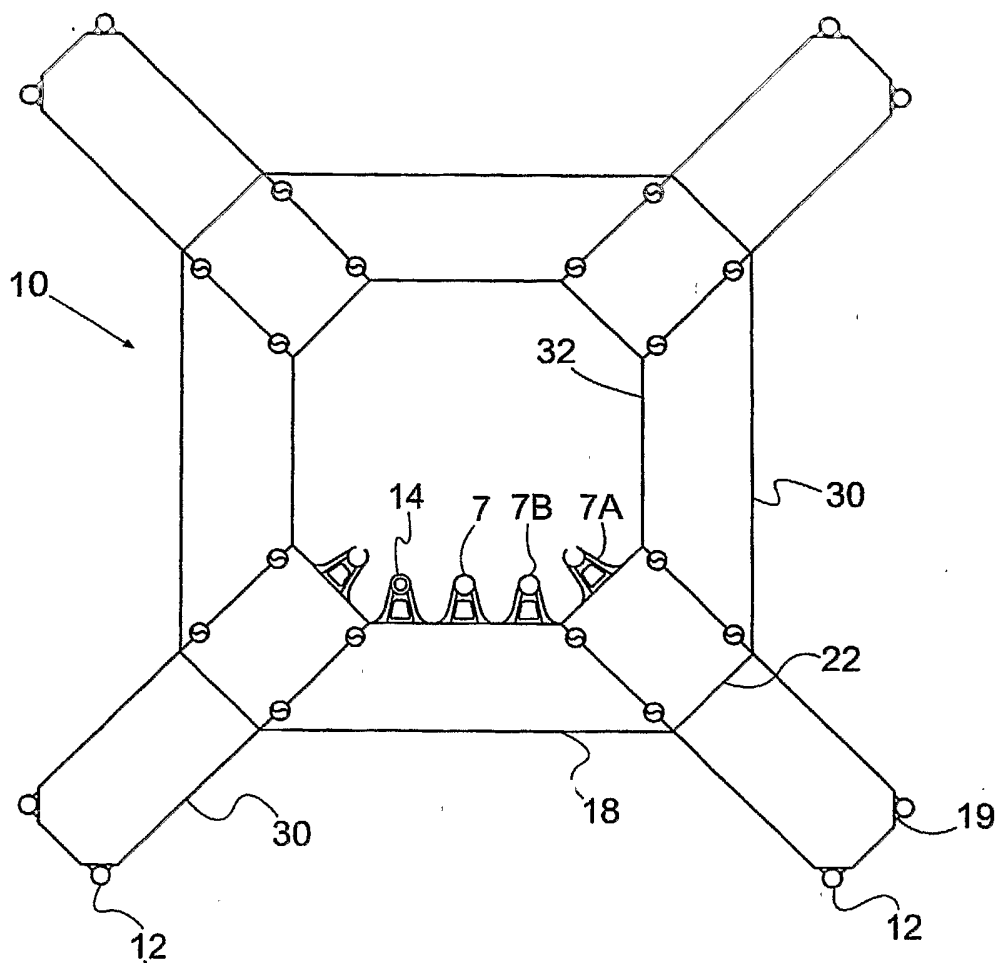

Fig. 11

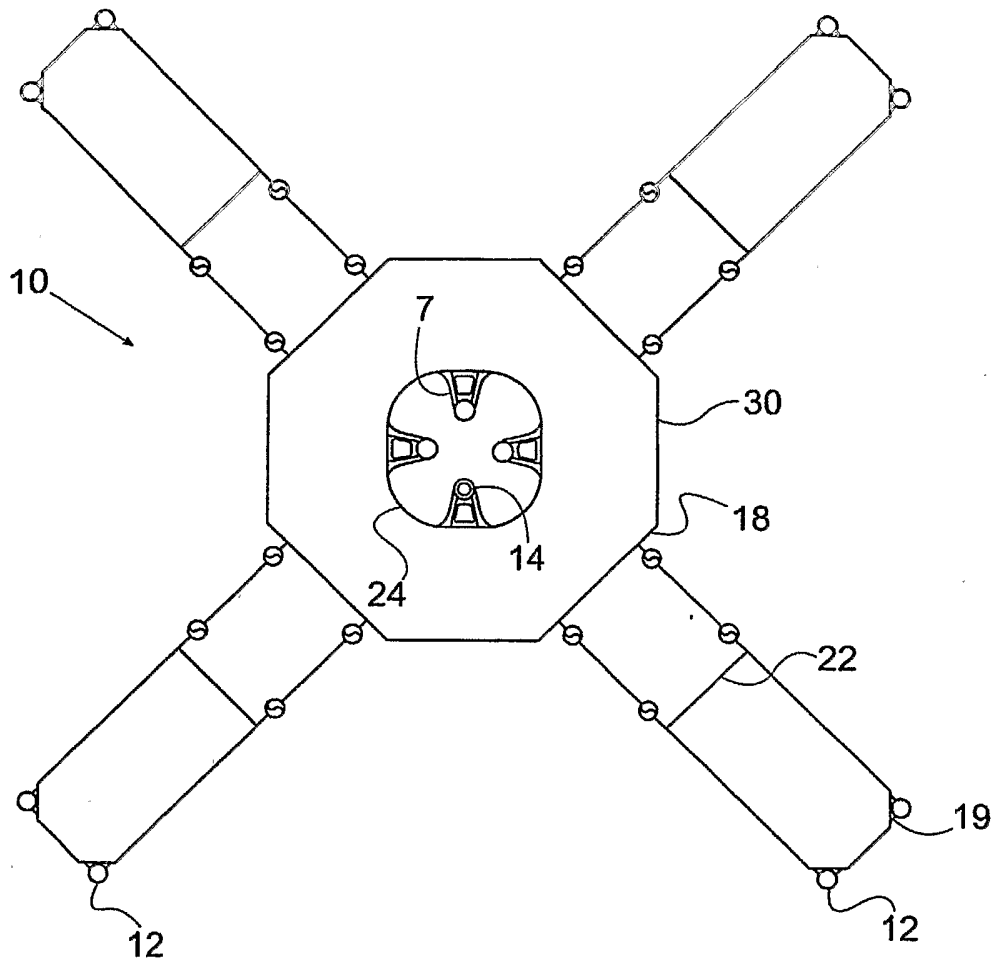

Fig. 12

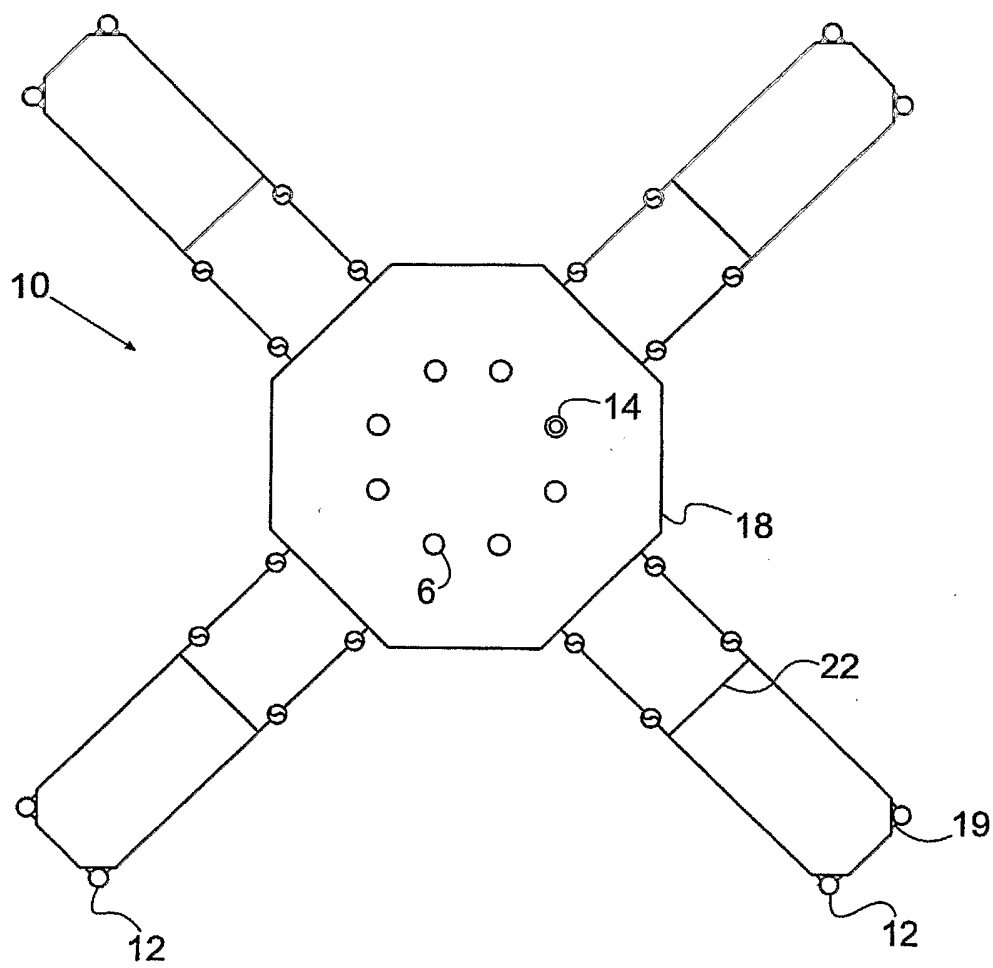

Fig. 13