

(19) **DANMARK**

(10) **DK/EP 2299231 T3**



Patent- og
Varemærkestyrelsen

(12) **Oversættelse af
europæisk patentskrift**

-
- (51) Int.Cl.: **F 28 F 9/013 (2006.01)**
- (45) Oversættelsen bekendtgjort den: **2017-03-27**
- (80) Dato for Den Europæiske Patentmyndigheds bekendtgørelse om meddelelse af patentet: **2016-12-21**
- (86) Europæisk ansøgning nr.: **10169523.7**
- (86) Europæisk indleveringsdag: **2010-07-14**
- (87) Den europæiske ansøgnings publiceringsdag: **2011-03-23**
- (30) Prioritet: **2009-09-02 DE 102009039816**
- (84) Designerede stater: **AL AT BE BG CH CY CZ DE DK EE ES FI FR GB GR HR HU IE IS IT LI LT LU LV MC MK MT NL NO PL PT RO SE SI SK SM TR**
- (73) Patenthaver: **Krones AG, Böhmerwaldstraße 5, 93073 Neutraubling, Tyskland**
- (72) Opfinder: **Justl, Johann, Hoppestraße 17, 93049 Regensburg, Tyskland**
- (74) Fuldmægtig i Danmark: **Larsen & Birkeholm A/S Skandinavisk Patentbureau, Banegårdspladsen 1, 1570 København V, Danmark**
- (54) Benævnelse: **Holdemodul til varmevekslerrør**
- (56) Fremdragne publikationer:
AU-A- 5 362 079
DE-A1-102007 017 564
DE-U1-202006 012 164
JP-A- S6 294 796
US-A- 5 404 941

The invention relates to a holding module for heat exchanger tubes according to claim 1, a rack for heat exchanger tubes with several holding modules according to claim 5, as well as a method for setting up a rack for heat exchanger tubes according to claim 10.

5

The use of heat exchangers, in particular tubular heat exchangers, for transmitting thermal energy from one medium to a second medium is widely spread. Depending on application, several tubular heat exchangers are combined in individual sections. The tubular heat exchangers e.g. comprise, as will be illustrated more in detail hereinafter, a heat exchanger tube, i.e. a casing tube in which a plurality of internal tubes is arranged, at least, however, one internal tube. The heat exchanger tubes are held by means of frames and shelf racks.

10

The conventional racks, however, require a lot of space, and the manufacture of such racks and their equipment are moreover complex and expensive. The size of the known racks is fixed and they cannot be flexibly extended.

15

Document JP S6294796A describes a holding module according to the generic clause of claim 1 and a method for setting up a rack for heat exchanger tubes with a holding module.

20

Starting from this situation, the object underlying the present invention is to provide a device and a method by means of which heat exchanger tubes can be held in a simpler, more space-saving and cheaper manner, where the device can be in particular flexibly extended.

25

According to the invention, this object is achieved by the features of claims 1 to 13.

According to the present invention, individual holding modules for the heat exchanger tubes are used for the modularly assembled rack. A holding module comprises a lower module half with several recesses into each of which one heat exchanger tube can be placed, as well as an upper holding module half which also comprises several recesses and which can be placed onto the lower holding module

30

half, such that its recesses are lying opposite to the recesses of the lower holding module half, such that the heat exchanger tubes are held in the recesses.

5 A connecting element connects the upper and the lower halves. Thus, the heat exchanger tube can be simply placed into the holding module, and the second half can then be placed on top. The rack is assembled in steps together with the piling up of the heat exchanger tubes. Level by level is piled up until a certain rack height is reached.

10 According to the present invention, a very compact construction can be achieved. By the modular structure, the height can be flexibly adapted to certain requirements. The height of the system can also be subsequently flexibly extended. The system can be extended as desired. The rack according to the invention is clearly less expensive than the known frame racks. The assembly of the individual modules is
15 also very simple and quick. Moreover, an improved design results.

20 According to the invention the connecting element which connects the upper and the lower holding module half is a plug-in element that can be plugged onto the lower holding module half, while the upper holding module half is plugged onto the plug-in element. Such a connecting element is inexpensive and moreover permits an easy assembly.

25 The plug-in element preferably extends in the longitudinal direction of the heat exchanger tubes and provides a stable connection.

Advantageously, the upper and lower holding module halves are constructed in the same way. Thus, the complete holding module can be manufactured very inexpensively.

30 According to the invention the upper and/or lower holding module half of the holding module is embodied such that it comprises an essentially U-shaped cross-section with two opposite side walls and an intermediate bottom, the recesses being embodied in the side walls. Thus, each module half comprises two support surfaces

for the heat exchanger tube and permits a good support for the heat exchanger tube. By the U-shaped embodiment, the weight of the holding module can be essentially reduced.

5 The plug-in element can be embodied e.g. such that it comprises at least two upper and/or at least two lower openings into which the side walls of the upper or the lower holding module half can be inserted, or else the lower holding module half and/or the upper holding module half is embodied such that they comprise openings in the side walls into which the plug-in element can be inserted.

10

A rack for the heat exchanger tubes comprises at least one first and one second unit in which several modules each are arranged one upon the other, where then the heat exchanger tubes arranged in parallel to each other are held by the first and the at least second unit. Depending on the length of the tubes, a varying number of units can be employed. Equally, depending on the diameter and number of the heat exchanger tubes, each level can be differently equipped. The units do not have to be filled completely. The modules arranged one upon the other in the units can be fixed to each other by a fixing means. To fix the modules in a respective unit, the modules can comprise e.g. through openings arranged one upon the other into which a fixing rod can then be inserted from above. Thus, the individual modules arranged one upon the other remain in correct orientation with respect to each other. For even better fixing, lateral crossbars can be arranged between the holding element units for bracing.

15

20

25

The lowermost holding module half of each holding module unit can be firmly connected to a bottom frame. Thus, the lowermost holding module half has a stable grip and permits secure assembly of the modules to be arranged thereabove.

30

In the method according to the invention, several holding module halves spaced apart are provided (step a). Then, the heat exchanger tubes are placed into the recesses of the lower holding module halves (step b). Finally, the several upper holding module halves are placed onto the tubes, such that the recesses face the tubes and receive them (step c). A lower holding module half can then be placed

again on the upper side of the now already installed upper holding module half to produce a further module (step d). Steps d, b, c can be repeated as often as desired until a desired rack height is reached.

5 After step a or b, the holding module halves are fixed. For this, after step a or b, at least one plug-in element can be inserted into the lower holding module half, and the upper holding module half can be placed onto the at least one plug-in element in step c. Thus, a simple self-supporting modular system is formed. The modules
10 arranged one upon the other in one unit can then be also fixed again to each other to achieve an altogether stable system.

The present invention will be illustrated below in greater detail with reference to the following figures:

15 Fig. 1 shows a holding module according to the present invention in a perspective representation;

Fig. 2 shows a lower holding module half with inserted plug-in element in a perspective representation;

20

Fig. 3 schematically shows a front view of a plug-in element according to the present invention;

25 Fig. 4 shows a perspective representation of three holding modules according to the present invention arranged one upon the other;

Fig. 5 shows a schematic perspective representation in partial elevation of a rack according to the present invention, wherein the heat exchanger tubes are not represented;

30

Fig. 6 schematically shows an example of a heat exchanger tube;

Fig. 7 shows a rack according to the present invention in a perspective

representation.

Figure 6 shows the basic structure of a heat exchanger tube 12. The heat exchanger tube 12 here comprises a casing or external tube 18 with an inlet 13 on the secondary side and an outlet 14 on the secondary side. In the casing tube 18, several internal tubes, at least, however, one internal tube or bank of tubes 17, respectively, are arranged which comprise a corresponding inlet 15 and outlet 16 on the primary side. The individual heat exchanger tubes 12 can be interconnected in individual sections, i.e. then, for example, the outlet 16 of a first heat exchanger tube is connected to the inlet 15 of a subsequent heat exchanger tube, e.g. arranged in parallel to it, and the outlet 14 is connected to the inlet 13 of a subsequent tube. The inlets 15 and outlets 16 can be interconnected, for example, via tube bends. The outlets 14 and the inlets 13 can also be connected by corresponding tube connections.

Figure 1 shows in a perspective representation a holding module for holding several heat exchanger tubes 12 extending in parallel with respect to each other, which are not represented here for the sake of simplicity. A holding module 1 comprises a lower holding module half 1b which comprises several recesses 3b into each of which one heat exchanger tube 12 can be placed, and an upper holding module half 1a which comprises several recesses 3a and which can be placed onto the lower holding module half 1b such that the recesses 3a are lying opposite to the recesses 3b, such that the heat exchanger tube can be firmly held in the recesses 3a, b. The inner diameter of the essentially circular recess 3a, b here essentially corresponds to the outer diameter of the heat exchanger tube 12, such that the tube is held to be protected from shifting.

Normally, the holding modules are designed such that one of the units 30, 31, 32, 33 serve as fixed, and the other ones as loose bedding, so that the different thermal expansions of the individual heat exchanger tubes with respect to the rack are compensated.

As can be taken in particular from Figure 2, each holding module half is embodied

such that it has a U-shaped cross-section, so that the holding module 1 is embodied to be hollow inside and only has a low weight. The openings 3a, b are embodied in the opposite side walls 5a, b and 6a, b of the module halves 1a, b. One bottom 7a, b each is situated between the side walls 5a, b and 6a, b. In this example, six
5 recesses 3a, b for six heat exchanger tubes arranged in parallel to each other in one level are provided. Advantageously, approximately two to ten such openings are provided next to each other. Angles 8a, b are shaped to the front and end side of the holding module 1, so that after the set up of the individual holding modules,
10 crossbars and/or a covering, as will be illustrated more in detail below, can be arranged. In both bottoms 7a, b, opposite openings 9a, b are provided into which a fixing rod 20 (see Figure 5) can be inserted for fixing holding modules arranged one upon the other.

To connect the two holding module halves 1a, b with each other, a connecting
15 element, preferably a plug-in element 11, is provided. The plug-in element can be plugged onto the lower holding module half 1b, while the holding module half 1a is plugged onto the plug-in element 1. Here, a holding module 3 comprises such plug-in elements 11. The number of plug-in elements 11 depends on the size of the holding module.

20 As can be in particular also taken from Figure 2, the plug-in element extends in the longitudinal direction of the heat exchanger tubes 12. Here, the plug-in element comprises two openings 19a at the upper side and two openings 19b at the bottom side. The side walls 6a, b and 5a, b can be inserted into these openings. As an
25 alternative to this, the lower holding module half 1b and the upper holding module half 1a can also comprise openings in the side walls into which the plug-in element 11, which then does not require any corresponding openings, can be inserted. Thus, a secure grip of the two holding module halves is ensured. Several holding modules 1 can be arranged one upon the other, as can be taken from Figure 4.

30 Figure 4 shows, for example, three holding modules 1 which are arranged one upon the other, where three heat exchanger tubes 12 have been inserted and the individual halves have been connected to each other by means of the plug-in

elements 11 during the assembly. This results in a self-supporting unit.

In Figure 5, a rack for heat exchanger tubes with several holding modules 1, as described above, are shown. The holding modules 1 correspond to the above
5 described holding modules. For the sake of simplicity, the heat exchanger tubes 12 are not represented in Figure 5. The rack comprises several units 30, 31, 32 in which several holding modules 1 are arranged one upon the other. In this embodiment, four units are provided. The heat exchanger tubes 12 arranged in parallel are held by the holding modules in the respective units 30, 31, 32, 33. The
10 lowermost holding module half 1b of each holding module unit 30 to 33 can be firmly fixed to a frame 27 which can stand on corresponding feet. Then, so many heat module halves and heat exchanger tubes are piled up level by level until a desired height is reached. If a desired height is reached, the modules 1 arranged one upon the other of each unit can be fixed to each other by a fixing means 9, 20. For this, a
15 through opening 9 (openings 9a, b, in the bottom of the holding module halves) is provided in each module 1, as already described above. A fixing rod 20 is pushed through the openings and for example fixed by screwing. Here, there are two fixing means 20, 9 per unit. The holding modules 1 piled one upon the other can then be braced between the units 30, 31, 32, 33, e.g. with crossbars 23. The crossbars 23
20 can be placed either directly at the modules (not represented), or else with frame parts 26 which are fixed between the units. In addition, side covering parts 21, 22 can be attached to the open sides of the rack. An upper covering 24 can also be arranged between the individual units. Here, the upper coverings 24, which comprise openings 25 above the corresponding openings 9, are also held by the
25 fixing rod 20. Figure 7 shows a rack with a covering.

The system according to the invention brings about the advantage that the number of heat exchanger tubes arranged in one level can be varied, i.e. that for example not all recesses must be occupied by tubes. The number of modules or tubes,
30 respectively, arranged one upon the other can also be simply varied by stacking the desired number of modules one upon the other.

At the front sides of the rack, the heat exchanger tubes 12 project (not represented)

and can be connected to each other via corresponding tube bends or connecting elements depending on the interconnection, as was also described in connection with Figure 6. Here, they can be connected vertically as well as horizontally. The center distance of the openings is identical in identical units.

5

In the method according to the invention for setting up the rack shown in Figure 5, first in a step a, several lower holding module halves 1b that are spaced apart are provided. Here, the holding module halves 1b are fixed to the frame 27. In a next step b, the heat exchanger tubes 12 are placed into the lowermost heat exchanger half 1b of each unit 30, 31, 32, 33 (step b). In each unit 30, 31, 32, 33, an upper holding module half 1a is now placed onto the tubes, such that the recesses 3a are facing the tubes 12 and receive and hold the same. After step a or b, here the plug-in element 11 is inserted into the lower holding module half 1b, the upper holding module half 1a being plugged into the plug-in element 11 in step c.

10

15

Then, a lower holding module half 1b of a further module can be placed onto the upper side of the upper holding module half 1a, so that the bottom 7b comes to lie on the bottom 7a.

20

Steps a, b, c can be repeated as often as desired until a predetermined rack height is reached. Then, the modules arranged one upon the other in the individual units 30, 31, 32, 33, can be fixed to each other via the fixing means 20, 9, as illustrated before, by passing the rod 20 through the openings 9 and screwing it down. Finally, cross bracings can be arranged and the longitudinal covering elements 21, the upper covering elements 24, and the lateral covering elements 22 can be arranged as desired. Frame parts 26 can be arranged between the individual units.

25

30

In this manner, the heat exchanger tubes can be very easily mounted. An attractive design results. The height of the modular structure can be flexibly extended. The compact design is extremely space-saving.

P A T E N T K R A V

1. Holdemodul (1) til varmevekslerrør (12) med en nedre holdemodulhalvdel (1b),
der udviser flere udsparinger (3b), hvori der i hver især kan lægges et varmevekslerrør
5 (12),
en øvre holdemodulhalvdel (1a), der udviser flere udsparinger (3a), og som kan sæt-
tes på den nedre holdemodulhalvdel (1b) på en sådan måde, at dens udsparinger
(3a) ligger over for udsparingerne (3b) i den nedre holdemodulhalvdel (3b) på en så-
dan måde, at varmevekslerrørene (12) holdes i udsparingerne (3a, b), og
10 mindst et forbindelseselement (11), der forbinder den øvre og nedre holdemodulhalv-
del (1b, a), **kendetegnet ved, at** forbindelseselementet (11) er et stikelement, der kan
sættes på den nedre holdemodulhalvdel (1b), hvor den øvre holdemodulhalvdel sæt-
tes på stikelementet (11), hvor den øvre og nedre holdemodulhalvdel (1b, a) har et U-
formet tværsnit med to modsatliggende sidevægge (5a, b; 6a, b) og en derimellem
15 liggende bund (7a, b), hvor udsparingerne (3a, b) er udformet i sidevæggene (5a, b).
2. Holdemodul ifølge krav 1, **kendetegnet ved, at** stikelementet (11) strækker sig
i varmevekslerrørenes (12) længderetning.
- 20 3. Holdemodul ifølge mindst et af kravene 1 til 2, **kendetegnet ved, at** den øvre
og nedre holdemodulhalvdel (1a, b) er ens i konstruktionen.
4. Holdemodul ifølge mindst krav 2, **kendetegnet ved, at** stikelementet (11) udvi-
ser mindst to øvre og/eller mindst to nedre åbninger (19a, b), hvori sidevæggene (5a,
25 b; 6a, b) af den øvre hhv. nedre holdemodulhalvdel (1b, a) kan indsættes, eller den
nedre holdemodulhalvdel (1b) og/eller den øvre holdemodulhalvdel (1a) udviser åb-
ninger i sidevæggene, hvori stikelementet (11) kan indsættes.
5. Stativ til varmevekslerrør (12) med flere holdemoduler (1) ifølge mindst et af
30 kravene 1 til 4, **kendetegnet ved** en første enhed (30), hvori flere moduler (1) er pla-
ceret over hinanden, og mindst en anden enhed (31, 32, 33), hvori flere moduler (1)
er placeret over hinanden, hvor varmevekslerrørene (12) hver især holdes af modu-
lerne (1) i den første og den mindst ene anden enhed.

6. Stativ ifølge krav 5, **kendetegnet ved, at** de over hinanden placerede moduler (1) i en respektiv enhed (30, 31, 32, 33) er fikseret til hinanden ved hjælp af en fikseringsindretning (20, 9).

5 7. Stativ ifølge krav 6, **kendetegnet ved, at** modulerne (1) til fiksering af modulerne (1) i en respektiv enhed (30, 31, 32, 33) udviser over hinanden placerede gennemgangsåbninger (9), hvori en fikseringsstang (20) kan indskydes.

10 8. Stativ ifølge mindst et af kravene 5 til 7, **kendetegnet ved, at** der mellem enhederne (30, 31, 32, 33) er placeret laterale tværstivere (23).

9. Stativ ifølge mindst et af kravene 6 til 9, **kendetegnet ved, at** den nedre holdemodulhalvdel (1b) i hver holdemodulenhed (30 til 33) er fast forbundet med en bundramme (27).

15

10. Fremgangsmåde til opstilling af et stativ til varmevekslerrør med et holdemodul ifølge krav 1 med følgende trin:

20

a) tilvejebringelse af flere med indbyrdes afstand liggende nedre holdemodulhalvdele (1b), hvor den øvre og nedre holdemodulhalvdel (1b, a) har et U-formet tværsnit med to modsatliggende sidevægge (5a, b; 6a, b) og en derimellem liggende bund (7a, b), hvor udsparingerne (3a, b) er udformet i sidevæggene (5a, b), og forbindelseselementet (11) er et stikelement, der kan sættes på den nedre holdemodulhalvdel (1b), hvor den øvre holdemodulhalvdel sættes på stikelementet (11),

25

b) ilægning af varemvekslerrørene (12) i udsparingerne (3b) i den nedre holdemodulhalvdel (1b),

c) pålægning af flere øvre holdemodulhalvdele (1a) på rørene (12) på en sådan måde, at udsparingerne (3a) er vendt mod rørene (12) og optager disse og

30

d) påsætning af en nedre holdemodulhalvdel (1b) på oversiden af den øvre holdemodulhalvdel (1a),

hvor trinene d), b), c) gentages så ofte, indtil en bestemt stativhøjde er nået.

11. Fremgangsmåde ifølge krav 10, **kendetegnet ved, at** holdemodulhalvdelene (1a, b) fikseres til hinanden.

5

12. Fremgangsmåde ifølge krav 2, **kendetegnet ved, at** efter trin a) eller b) sættes mindst et stikelement (11) i den nedre holdemodulhalvdel (1b), og den øvre holdemodulhalvdel (1a) sættes i trin c) på det mindst ene stikelement (11).

10

13. Fremgangsmåde ifølge mindst et af kravene 10 til 12, **kendetegnet ved, at** de i en enhed (30 – 33) over hinanden placerede moduler (11) fikseres til hinanden.

1/5

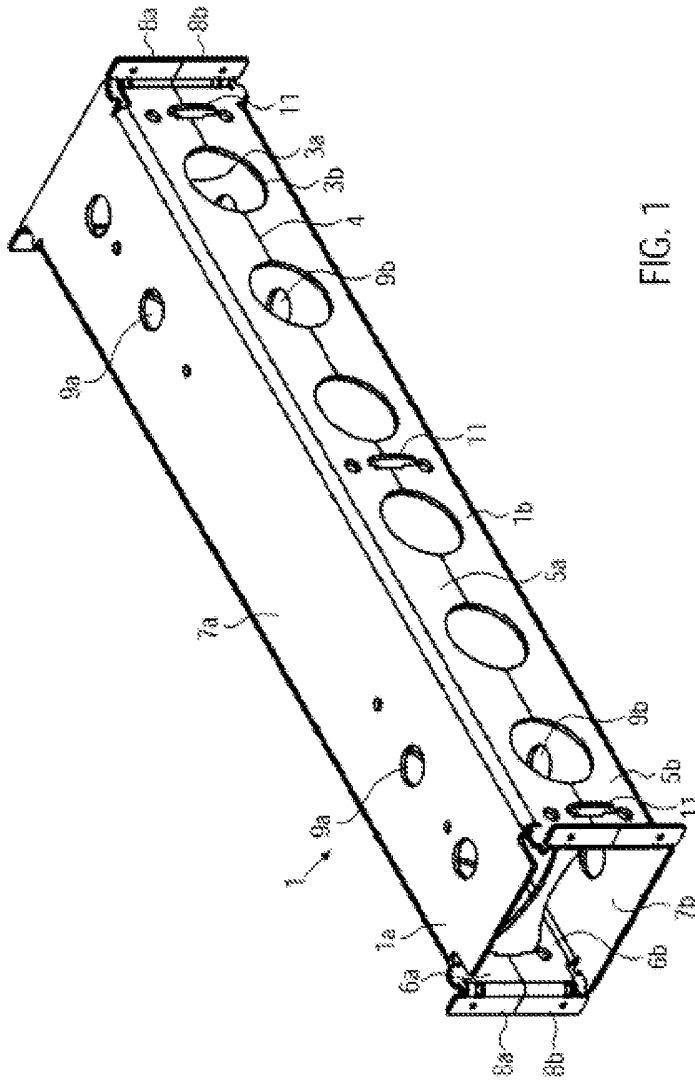

FIG. 1

2/5

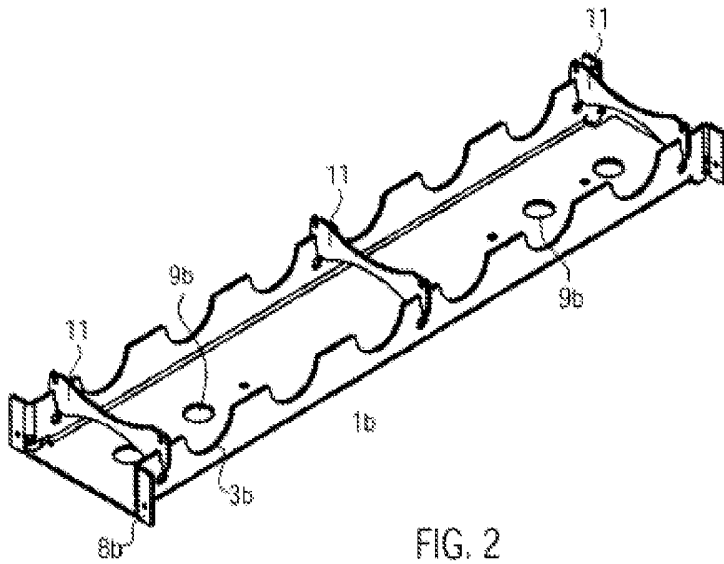

FIG. 2

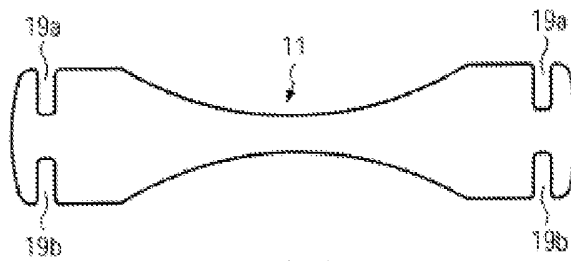

FIG. 3

3/5

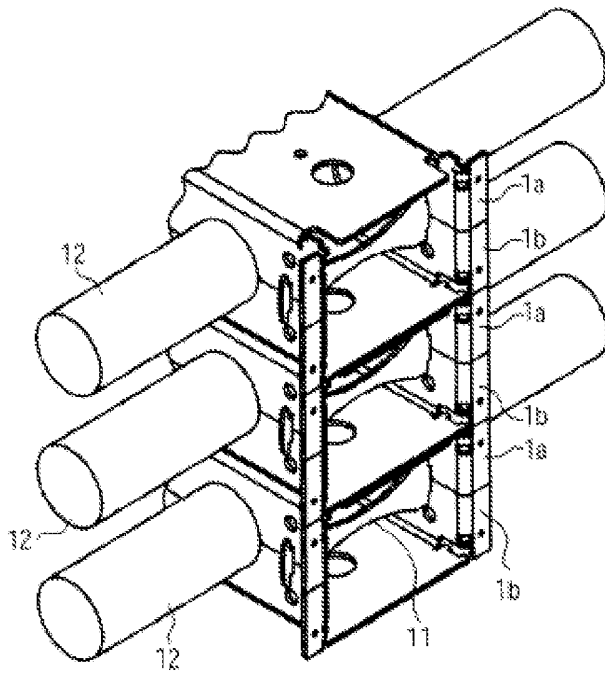
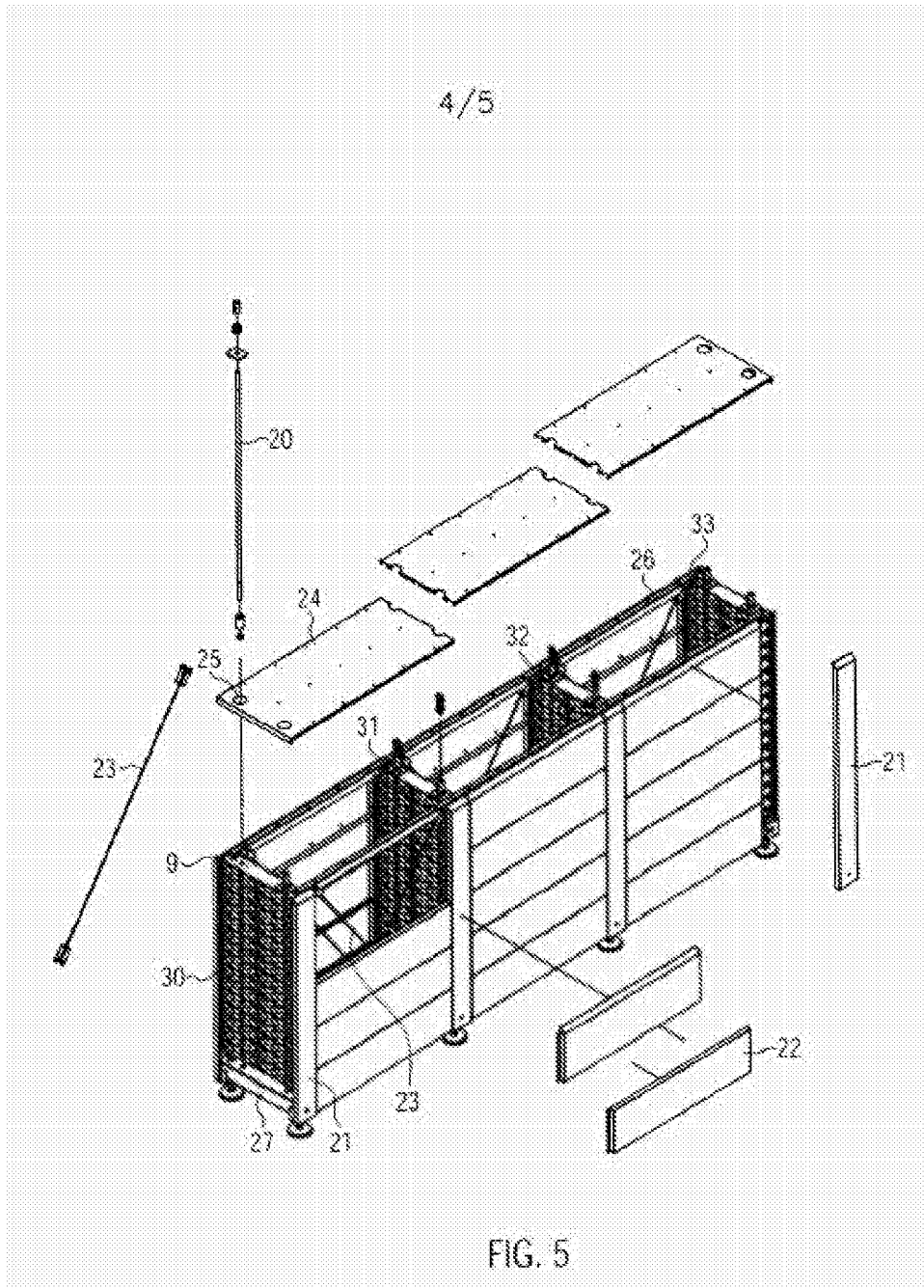

FIG. 4



5/5

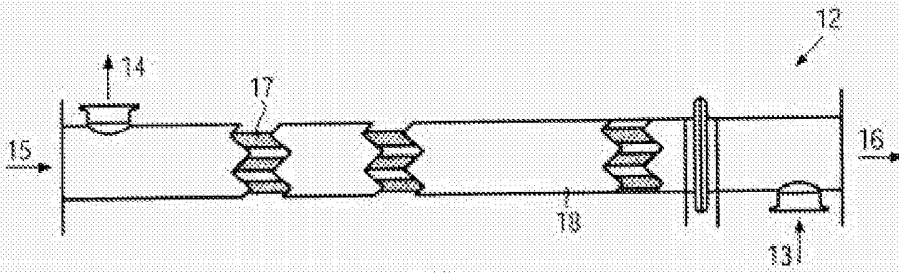

FIG. 6

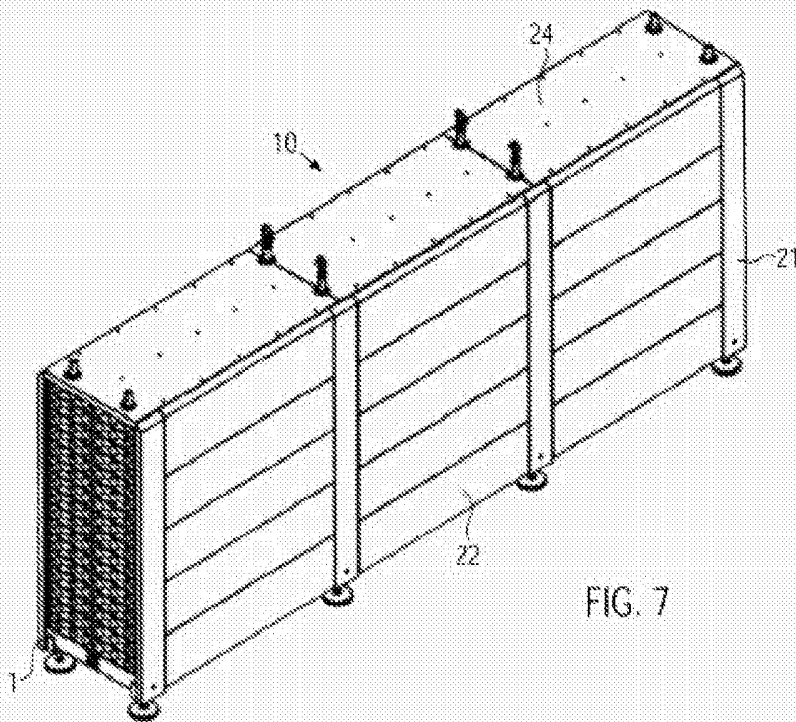

FIG. 7