

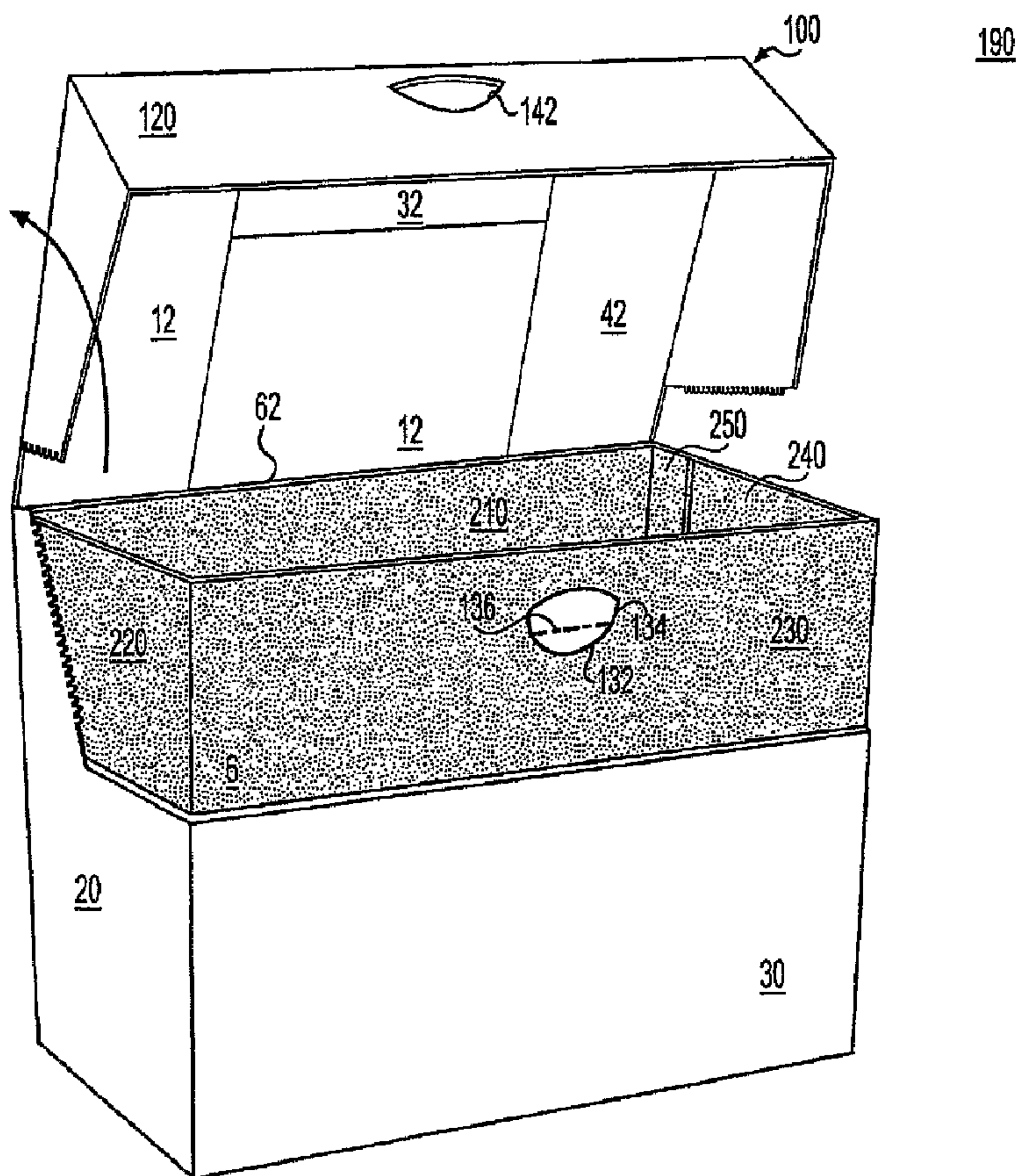

(86) Date de dépôt PCT/PCT Filing Date: 2007/04/10
 (87) Date publication PCT/PCT Publication Date: 2007/10/25
 (45) Date de délivrance/Issue Date: 2011/11/22
 (85) Entrée phase nationale/National Entry: 2008/10/06
 (86) N° demande PCT/PCT Application No.: US 2007/008823
 (87) N° publication PCT/PCT Publication No.: 2007/120650
 (30) Priorité/Priority: 2006/04/10 (US60/790,648)

(51) Cl.Int./Int.Cl. *B65D 5/54* (2006.01)
 (72) Inventeurs/Inventors:
 FITZWATER, KELLY R., US;
 CONATSER, ROBERT L., US
 (73) Propriétaire/Owner:
 GRAPHIC PACKAGING INTERNATIONAL, INC., US
 (74) Agent: MACRAE & CO.

(54) Titre : CARTON RENFORCE AVEC COUVERCLE REFERMABLE
 (54) Title: REINFORCED CARTON WITH RECLOSABLE LID



(57) Abrégé/Abstract:

A carton (190) is formed from two or more laminated webs (A, B) that can be cut, scored, or otherwise provided with lines of weakening. The carton includes reclosable pivotable lid (100) that can be secured in a closed position by a latch (130).

ABSTRACT

A carton (190) is formed from two or more laminated webs (A, B) that can be cut, scored, or otherwise provided with lines of weakening. The carton includes reclosable pivotable lid (100) that can be secured in a closed position by a latch (130).

REINFORCED CARTON WITH RECLOSABLE LID**FIELD OF THE INVENTION**

[0001] The present invention related to reinforced cartons, and more specifically to a reinforced carton with a reclosable lid.

BACKGROUND

[0002] Cartons are typically shipped in bulk quantities. During shipping, the cartons may be vertically stacked upon each other in order to maximize the amount of product shipped in a particular vessel. The amount of product shipped may depend, however, on the load-bearing capacity of the stacked cartons. It is therefore desirable to produce cartons having high rigidity and/or strength in compression for shipping, and for other purposes such as the protection of the carton contents in general.

[0003] A conventional method for increasing the strength of a carton is to produce the carton from a blank of a different, stronger board material, or to produce the blank from the same carton material but of greater thickness or caliper. Such methods typically increase the costs associated with manufacturing the carton, with the material costs of manufacture generally increasing according to the cost of increasing the strength and/or thickness of the entire blank. Some sections of the blank, however, may not be load-bearing, and the additional costs associated with increasing the strength of non-load bearing sections of the blank are wasted.

[0004] According to one aspect of the present invention there is provided a carton formed at least from an outer blank and an inner blank adhered to the outer blank, comprising a multi-ply front panel formed at least from the inner blank and the outer blank; a multi-ply first end panel formed at least from the inner blank and the outer blank; a multi-ply back panel formed at least from the inner blank and the outer blank; a multi-ply second end panel formed at least from the inner blank and the outer blank; a top panel; and a bottom panel, wherein a lid pattern is formed at least in the front panel, the first end panel and the second end panel, the lid pattern at least partially defining a latch and a pivotable lid, a base portion of the latch is formed in the outer blank and is adhered to the inner blank, and the lid pattern

defines at least part of a lower edge of the pivotable lid, and the latch is defined at least partially by a perimeter line of disruption in the outer blank.

[0005] Insert members may be introduced into certain carton structures to increase carton strength. Features of a certain complexity such as insert members, however, may require the carton blank to be prepared in a batch process, where features or articles are individually cut and/or glued to the carton blank. Batch processing may be slow, however, and may involve high costs.

SUMMARY

[0006] According to a first exemplary embodiment of the invention, a carton is formed from an inner blank adhered to an outer blank. A lid pattern is formed at least in the outer blank and defines a pivotable lid in a top portion of the carton. When opened, the lid separates from the inner blank ply of the carton and can be pivoted between open and closed positions.

[0007] According to one aspect of the first embodiment, the inner blank forms a reinforcing sleeve lining on an inner surface of the outer blank that increases the strength of the carton. The inner blank can be configured to reinforce the exterior blank at any number of desired locations. Selected reinforcement of specific areas of the exterior blank can produce a high strength carton while using relatively small amounts of board.

[0008] According to another aspect of the first embodiment, a latch feature can be formed in the carton that allows the lid to be selectively opened and reclosed. The latch feature can incorporate portions of the inner and outer blank that interact to maintain the lid in a closed position.

[0009] According to yet another aspect of the invention, multi-ply carton blanks can be formed in a continuous process where outer and inner webs are individually and/or simultaneously provided with repeating patterns of disruption. The outer and inner webs are joined together in the continuous process to form carton blanks that have one or more multi-ply sections. The inner and outer carton blanks can be formed from material webs that are capable of, for example, continuous and

simultaneous processing on the same production line so that the multi-ply blanks are quickly and easily manufactured.

[0010] Other aspects, features, and details of the present invention can be more completely understood by reference to the following detailed description, taken in conjunction with the drawings and from the appended claims.

BRIEF DESCRIPTION OF THE DRAWING FIGURES

[0011] FIG. 1 is a schematic illustration of a continuous process production line for producing multi-ply carton blanks.

[0012] FIG. 2A is a plan view of a multi-ply blank used to form a carton having a reclosable lid according to a first embodiment of the invention.

[0013] FIG. 2B is an isolated plan view of an inner blank ply of the multi-ply blank of FIG. 2A.

[0014] FIG. 3 illustrates adhesive lines formed by the production line illustrated in FIG. 1.

[0015] FIG. 4 illustrates a pattern of lines of disruption formed in a first material web by the production line illustrated in FIG. 1.

[0016] FIG. 5 illustrates a pattern of lines of disruption formed in a second material web by the production line illustrated in FIG. 1.

[0017] FIG. 6 illustrates a pattern of lines of disruption formed in the first and second material webs.

[0018] FIG. 7 illustrates the multi-ply carton according to the first embodiment of the invention.

[0019] FIGS. 8 and 9 illustrate opening of the reclosable lid of the first carton embodiment.

[0020] FIG. 10 illustrates reclosure of the reclosable lid.

DETAILED DESCRIPTION

[0021] Briefly described, an aspect of the present invention is directed to a multi-ply carton 190 (illustrated in FIG. 7) having enhanced strength and rigidity. The carton 190 is formed from a multi-ply blank 8 (illustrated in FIG. 2A) comprising

an exterior blank **5** reinforced with one or more interior reinforcing blanks adhered to the exterior blank. The multi-ply carton **190** may have a pivotable lid that is easy to access, open, and reclose. The lid may also interact with a reinforcing blank to prevent product from escaping the carton when the lid is closed. In this specification, the terms “bottom,” “front,” “back,” “end” and “top” are used to indicate orientations determined in relation to fully erected cartons placed in upright configurations, and are not intended to limit the scope of the invention.

[0022] The multi-ply blank **8** used to form a carton **190** may be formed, for example, in a continuous process production line capable of forming multi-ply blanks. **FIG. 1** is a schematic illustration of such a continuous process production line. In **FIG. 1**, first and second webs of material **A** and **B** are unrolled continuously and processed in the production line. The web **A** may be provided with lines of disruption at a disrupting station **D**. The web **B** may be provided with adhesive at station **E** before the webs **A** and **B** are laminated together at a lamination station **F**. The combined webs **A, B** are subsequently passed through a disrupting station **G**. The laminated webs **A, B** may then be separated into individual multi-ply carton blanks **8** at the disrupting station **G**, and also provided with additional lines of disruption in the combined webs **A, B**. The combined webs **A, B** are generally separated into the individual, multi-ply blanks **8** at locations between repeating patterns of lines of disruption in the webs **A, B**. Repeating patterns of disruption in the web **B** may differ, for example, from patterns formed in the web **A**, if any, so that the individual plies of the laminate blanks **8** have different properties and/or capabilities.

[0023] Referring to **FIG. 2A**, the multi-ply blank **8** used to form the carton **190** is formed from an outer blank **5** and an inner, reinforcing blank **6** adhered, laminated or otherwise joined to the outer blank **5**. The outer blank **5** can be formed from, for example, a web of continuously moving web of material such as the web **B** shown in **FIG.1**, and the inner blank **6** can be formed from a continuously moving web of material such as the web **A**. The terms “outer” and “inner” are used in this specification to indicate the location of the respective blank plies **5, 6** in cartons formed or erected from the finished multi-ply blanks **8**.

In **FIG. 2A**, the entire outer or exterior print surface of the outer blank **5** is visible, and the inner blank **6** is joined to the opposite, interior or underside of the outer blank **5**. The inner blank **6** is not visible in **FIG. 2A** and the lead line from reference number **6** is therefore shown by dashed lines. Upper and lower edges **7** and **9**, respectively, of the inner blank **6** are indicated in **FIG. 2A** by dashed hidden lines. The inner blank ply **6** is illustrated separately (i.e., in isolation) in **FIG. 2B**.

[0024] The final multi-ply blank **8** is “multi-ply” in that the joined inner and outer blank plies **6** and **5** comprising the multi-ply blank **8** include substantial overlapping portions. Also, a majority of the overlapping surfaces of the inner and outer blank plies **6**, **5** may be adhered adjacent to one another. For example, the blanks **5** and **6** have slightly different perimeters or “footprints” and do not overlap at all points, but at least substantially all of the surface of the inner blank **6** is adjacent and/or adhered to the outer blank **5**.

[0025] Referring again to **FIG. 2A**, the outer blank ply **5** comprises a back panel **10** foldably connected to a first end panel **20** at a first transverse fold line **21**, a front panel **30** foldably connected to the first end panel **20** at a second transverse fold line **31**, and a second end panel **40** foldably connected to the front panel **30** at a third transverse fold line **41**. An adhesive panel **50** may be foldably connected to the second end panel **40** at a fourth transverse fold line **51**. The blank **8** is two-ply where the inner blank **6** overlaps the sections of the outer blank **5** defined by the panels **10**, **20**, **30**, **40**, **50**.

[0026] The back panel **10** is foldably connected to a back top flap **12** and a back bottom flap **14**. The first end panel **20** is foldably connected to a first end top flap **22** and a first end bottom flap **24**. The front panel **30** is foldably connected to a front top flap **32** and a front bottom flap **34**. The second end panel **40** is foldably connected to a second end top flap **42** and a second end bottom flap **44**. The top flaps **12**, **22**, **32**, **42** extend along a first or top marginal area of the outer blank **5**, and may be foldably connected along a first longitudinally extending fold line **62**. The bottom flaps **14**, **24**, **34**, **44** extend along a second or bottom marginal area of

the outer blank **5**, and may be foldably connected along a second longitudinally extending fold line **64**.

[0027] The first and second longitudinal fold lines **62**, **64** may be, for example, generally straight fold lines, or, the fold lines **62**, **64** may be offset at one or more locations to account for, for example, blank thickness or other factors. When the carton **190** (**FIG. 7**) is erected, the top flaps **12**, **22**, **32**, **42** close a top of the carton **190**, and the bottom flaps **14**, **24**, **34**, **44** close a bottom of the carton **190**. The front top flap **32** can include a longitudinal fold line **35** defining a distal section **36** in the front top flap **32**. The front bottom flap **34** can include a longitudinal fold line **33** defining a distal section **38**.

[0028] The upper and lower edges **7**, **9** of the inner blank **6** are spaced a small distance within the first and second longitudinal fold lines **62**, **64**, respectively. The clearances between the edges **7**, **9** of the blank **6** and the respective fold lines **62**, **64** in the outer blank **5** allow the top and bottom flaps **12**, **22**, **32**, **42**, **14**, **24**, **34**, **44** to be folded inwardly when erecting the carton **190**.

[0029] According to one aspect of the invention, the outer blank **5** is provided with a lid pattern **80** comprising lines of disruption that define a pivotable lid **100** (illustrated in **FIGS. 7-10**) in the multi-ply carton **190**. The lines of disruption forming the lid pattern **80** may be formed, for example, so that they do not extend into the inner blank ply **6**, or extend into the inner ply a small degree.

[0030] The lid pattern **80** includes oblique breachable lines of disruption **102**, **104** that extend across the end panels **20**, **40**, respectively, and define the side edges of a front wall **120** of the lid **100**. The breachable lines of disruption **102**, **104** may be, for example, tear lines formed from a series of cuts and/or perforations. A pair of spaced parallel breachable lines of disruption **106**, **108** extend through the panels **20**, **30**, **40** and define a tear strip **116** that defines a lower edge of the front wall **120**. The breachable lines of disruption **102**, **104** may be, for example, tear lines formed from a cut-scores. Arcuate cuts **110**, **112** may be formed in the cut-score **108** to facilitate tearing of the tear strip **116**. Nicks may be formed at one end of the tear strip **116** to define a tear tab **118** at an end of the tear strip **116**.

- [0031] According to one aspect of the invention, a click-shut latch 130 is formed in the outer blank 5, and has an outer perimeter defined by a breachable perimeter line of disruption 140. The breachable perimeter line of disruption 140 may be formed from, for example, a series of cuts and/or perforations. A base portion 134 of the click-shut latch 130 is foldably connected to a latch tab or flap 132 at a longitudinal hinge or fold line 136. The pivotable lid 100 (FIG. 7) defined in the outer blank 5 may remain unadhered to the inner blank 6, except at the base 134 of the click-shut latch 130. The pattern of adhesion of the inner blank 6 to the outer blank 5 is described in detail below with reference to FIGS. 2B and 3.
- [0032] FIG. 2B is an isolated plan view of the side of the inner ply or blank 6 that is adhered to the outer blank 5. In FIG. 2B, the inner ply 6 is shown separate and isolated from the outer blank 5 in order to more clearly illustrate the lines of disruption formed in the inner blank 6. The inner blank ply 6 comprises a back panel 210 foldably connected to a first end panel 220 at the transverse fold line 21, a front panel 230 foldably connected to the first end panel 220 at the transverse fold line 31, a second end panel 240 foldably connected to the front panel 230 at the transverse fold line 41, and an adhesive panel 250 foldably connected to the back panel 210 at a transverse fold line 51. The common reference numbers for the transverse fold lines 21, 31, 41, 51 in the blanks 5, 6 are used to indicate that the fold lines in the inner and outer blank 5, 6 can be formed in a single disrupting operation (e.g., in the same nip defined by the male and female rollers G1, G2 of the disrupting station G shown in FIG. 1). In accordance with the first embodiment, this method of production ensures that the panels 210, 220, 230, 240, 250 of the inner blank 6 generally correspond to and align with the panels 10, 20, 30, 40, 50 respectively, in the outer blank 5.
- [0033] FIG. 3 is an adhesive or glue target drawing illustrating the locations of longitudinally extending adhesive lines 160, 162, 164, 166, 168, 170, 172, 174 formed on the outer blank 5 in order to adhere the inner blank 6 to the outer blank 5. One or more of the adhesive lines 160, 162, 164, 166, 168, 170, 172, 174 may alternatively be applied to the inner blank 6 to adhere the blanks 5, 6 together. The adhesive lines 160, 162, 164, 166, 168, 170, 172, 174 may be applied, for

example, at the adhesive application station **E** shown in **FIG. 1**. As shown in **FIG. 3**, the area of the outer blank **5** within the lid pattern **80** is free of adhesive except at the base **134** of the click-shut latch **130**. This allows the lid **100** formed from the lid pattern **80** to pivot away from the inner blank **6** when the latch **130** is breached. The adhesive lines **160**, **172** extend longitudinally alongside an upper portion of the lid pattern **80** so that the inner blank **6** is adhered to the outer blank substantially to an upper edge of the carton **190** (shown in **FIG. 9**).

[0034] An exemplary continuous processing method of forming multi-ply blanks **8** is discussed below with reference to **FIGS. 1-6**.

[0035] Referring to **FIG. 1**, the first and second webs of material **A** and **B** are unrolled continuously from rolls. The outer blank **5** can be formed from the web **B** and the inner blank **6** can be formed from the web **A**. Referring also to **FIG. 4**, the first or inner web **A** can be provided with longitudinal cuts that define the upper and lower edges **7** and **9** of the inner blank **6**. The longitudinal cuts can be provided if the roll of inner web material **A** has an initial width that is greater than the width of the final inner blank **6**. The second or outer web **B** may then be provided with the adhesive pattern illustrated in **FIG. 3**. In **FIG. 1**, the adhesive station **E** is schematically illustrated by a glue spray nozzle arrangement. Other apparatus for applying adhesive, such as print rollers, for example, can also be used to apply an adhesive pattern to the outer web **B**. After the application of adhesive, the webs **A** and **B** are laminated together at lamination station **F** (e.g., by passing the webs through a nip defined between opposed rollers).

[0036] Referring to **FIGS. 1, 5** and **6**, the disrupting station **G** forms the patterns of disruption shown in **FIGS. 5** and **6** in the combined web **A, B**. The disrupting station **G** may, for example, form differing patterns of lines of disruption in each of the webs **A, B**. In the exemplary embodiment, the disrupting station **G** repeats the pattern shown in **FIG. 5** end-to-end continuously in only the outer web **B** as the web is advanced through the continuous process production line. The pattern shown in **FIG. 6** is formed in both the outer web **B** and the inner web **A**.

[0037] As described above, the disrupting station **G** can comprise the first male roller **G1** and the second female roller **G2** with respective male and female die

patterns for forming the patterns shown in **FIGS. 5** and **6**. With respect to the pattern shown in **FIG. 5**, the portions of the disrupting die used to form the outer web **B** may also disrupt the inner web **A** to some small degree. However, the pattern shown in **FIG. 5** is not intended to be formed in the inner web **A** such that the functions associated with the pattern shown therein, particularly the lid pattern **80**, are imparted to the inner web **A**.

[0038] Both the inner web **A** and the outer web **B** are provided with the pattern of lines of disruption shown in **FIG. 6**. The pattern shown in **FIG. 6** is repeated end-to-end continuously in the combined webs **A** and **B** as the webs are advanced through the production line. The perimeter cuts shown in **FIG. 6** separate the processed webs **A, B** into individual blanks **8**. The resultant blanks **8** then exit the station **G** as shown in **FIG. 1**. Scrap material from the joined webs **A, B** can be removed at this time.

[0039] The patterns illustrated in **FIGS. 5** and **6** are illustrated as formed at a single disrupting station **G** (e.g., nip) comprising opposed male and female die rollers. In an alternative embodiment, flat reciprocating dies can be used at the disrupting station **G**. In accordance with the first embodiment, the lines of disruption shown in **FIGS. 5** and **6** are formed "simultaneously" in the sense that they are formed at the same disrupting station **G**. In the exemplary embodiment, the respective patterns are formed simultaneously in that a single pair of rollers **G1, G2** forms the patterns. The patterns in **FIGS. 5** and **6** may also be formed by the same reciprocating die at the disrupting station **G**.

[0040] An exemplary method of constructing the carton **190** from the blank **8** is discussed below.

[0041] Referring to **FIGS. 2A, 2B** and **3**, the carton **190** may be erected by folding the multi-ply blank **8** flat about the transverse fold lines **21, 41** and adhering the exterior side of the adhesive panel **50** to the interior side of the second end panel **240** of the inner blank **6**. The multi-ply blank **8** may then be "opened" to have a generally rectangular tubular shape. To close the bottom of the tubular carton form, the first and second end bottom flaps **24, 44** are folded inwardly, followed by the back bottom flap **14**, then the front bottom flap **34**. The

underside of the front bottom flap 34 is adhered to the exterior side of the back bottom flap 14. Portions of the first and second end bottom flaps 24, 44 may also be adhered to one or both of the bottom flaps 14, 34. To close the top of the tubular carton form, the first and second end top flaps 22, 42 are folded inwardly, followed by the back top flap 12, then the front top flap 32. The underside of the front top flap 32 is adhered to the exterior side of the back top flap 12. Portions of the first and second end top flaps 22, 44 may also be adhered to the flaps 12, 32. The flaps 12, 22, 32, 42, 14, 24, 34, 44 may be adhered by, for example, glue, adhesives, or other means. Dispensable product, such as, for example, laundry detergent, or other items, can be loaded into the carton at any time before fully enclosing the carton. Other articles and dispensable products may also be accommodated within the carton.

[0042] FIG. 7 illustrates the erected carton 190 with the top and bottom ends of the tubular form closed. The erected carton 190 has a generally parallelepipedal form, with the outer blank 5 forming an outer ply of the carton, and the inner blank 6 (not visible in FIG. 7) reinforcing the carton interior. Referring also to FIG. 1, the portion of the outer blank 5 defined by the lid pattern 80 in part defines a reclosable lid 100 in an upper portion of the carton 190. As shown in FIG. 7, the tear strip 116 extends partially around the perimeter of the carton 190.

[0043] FIGS. 8-10 illustrate opening and reclosing of the pivotable lid 100. In FIGS. 8-10, the surface of the inner blank 6 is shaded with stippling solely to distinguish the inner blank from the outer blank 5, which is not shaded. Referring to FIG. 8, the pivotable lid 100 may be opened by grasping the tear tab 118 (shown in FIG. 1) and removing the tear strip 116 along the tear lines 106, 108. The lid 100 may now be pivoted upward so that the outer blank 5 tears along the oblique lines of disruption 102 in the outer blank 5. If perforations are used to form the perimeter 140 of the latch 130, the user may also press in at the base 134 and/or tab 132 to pre-break the perforation 140 before pivoting the lid 100 open. The lid 100 can then be pivoted open about the fold or hinge line 62 as shown in FIG. 9. As shown in FIG. 9, the base 134 of the latch 130 is adhered to the inner blank 6 and separates from the remainder of the lid 100, which creates a latch

aperture or opening **142** in the front wall **120** of the lid **100**. The latch tab **132** remains attached to the base **134** and also separates from the lid **100**. The inner blank **6** may remain intact and constitutes a reinforcing sleeve in the interior of the carton **190**.

[0044] Referring to **FIG. 10**, the lid **100** may be reclosed by first bending the latch tab **132** upwardly at the fold line **136** so that the latch tab **132** projects outwardly from the inner blank **6** in a latching position. Alternatively, opening of the lid **100** may be sufficient to bend the latch tab **132** to its latching position. The lid **100** is pivoted downwardly and selectively secured in a closed state by engaging the latch tab **132** with the perimeter of the latch opening **142**. It is not required that the latch tab **132** bend outwardly to secure the lid in its closed position.

[0045] The pivotable lid **100** can be opened again by lifting upwardly on the lid **100** to disengage the latch tab **132** from the latch opening **142**. According to the above embodiment, the latch tab **132** can emit an audible noise, such as a 'click,' when the tab **132** is engaged and/or disengaged with the latch opening **142**.

[0046] According to the above embodiment, the carton **190** may be used as a dispensing container for detergent and other particulate product. The carton **190** may be formed, for example, such that there are substantially no gaps between the laminated plies of the carton. The folding and gluing process may be greatly simplified through the elimination of separate insert pieces and the related equipment, resulting in faster production.

[0047] Also according to the above embodiment, an exterior carton blank can be selectively reinforced at desired locations by one or more reinforcing blanks. The carton formed from the resulting multi-ply blank can accordingly have enhanced strength and rigidity at selected sections of the carton. Selected reinforcement of specific areas of the exterior blank produces a high strength carton while using comparatively small amounts of board material.

[0048] In accordance with the exemplary embodiments, the cartons may be constructed of paperboard, for example. The webs used to form the blanks may be thicker and heavier than ordinary paper. The blanks, and thus the cartons, can also

be constructed of other materials, such as cardboard, or any other material having properties suitable for enabling the carton to function at least generally as described above. For example, one or both of the blanks may be formed from coated solid unbleached sulfate (SUS) board.

[0049] One or more panels of the blanks discussed above can be coated with varnish, clay, or other, similar materials, either alone or in combination. The coating may then be printed over with product, advertising, usage and other information or images. The blanks may also be coated to protect any information printed on the blank. The blanks may be coated with, for example, a moisture barrier layer, on either or both sides of the blanks.

[0050] In accordance with the exemplary embodiment of the present invention, a fold or hinge line can be any substantially linear, although not necessarily straight, line of disruption in the blank that facilitates folding or hinged pivoting therealong during ordinary use and/or erection of a carton. More specifically, but not for the purpose of narrowing the scope of the present invention, fold lines include: score lines; crease lines; a cut or a series of cuts that extend partially into and/or completely through a blank along a desired line of weakness; and various overlapping and sequential combinations of these features.

[0051] The above embodiments may be described as having one or panels adhered together by glue. The term "glue" is intended to encompass all manner of adhesives commonly used to secure carton panels in place.

[0052] For purposes of the description presented herein, the term "line of disruption" can be used to generally refer to a cut line, a score line, a tear line, a crease line, perforations, or a fold line formed in blank material (or a combination of at least one cut line, score line, tear line, crease line, and/or fold line), or any form of disruption in a blank, whether continuous or non-continuous. A "breachable line of disruption" as disclosed in this specification refers to a line of disruption that is intended to be breached or otherwise torn during ordinary use of a carton. A tear line can be any breachable line of disruption as understood in the art that facilitates tearing therealong during ordinary use of the carton.

- [0053]** In the present specification, the terms “panel” and “flap” may generally indicate portions of blanks wholly or partially demarcated by lines of disruption. A “panel” or “flap” need not be flat or otherwise planar. A “panel” or “flap” can, for example, comprise a plurality of interconnected and/or overlapping generally flat or planar blank sections.
- [0054]** The term “line” as used herein includes not only straight lines, but also other types of lines such as curved, curvilinear or angularly displaced lines.
- [0055]** It will be understood by those skilled in the art that while the present invention has been discussed above with reference to exemplary embodiments, various additions, modifications and changes can be made thereto without departing from the spirit and scope of the invention as set forth in the following claims.

WHAT IS CLAIMED IS:

1. A carton formed at least from an outer blank and an inner blank adhered to the outer blank, comprising:

a multi-ply front panel formed at least from the inner blank and the outer blank;

a multi-ply first end panel formed at least from the inner blank and the outer blank;

a multi-ply back panel formed at least from the inner blank and the outer blank;

a multi-ply second end panel formed at least from the inner blank and the outer blank;

a top panel; and

a bottom panel, wherein

a lid pattern is formed at least in the front panel, the first end panel and the second end panel, the lid pattern at least partially defining a latch and a pivotable lid,

a base portion of the latch is formed in the outer blank and is adhered to the inner blank, and

the lid pattern defines at least part of a lower edge of the pivotable lid, and

the latch is defined at least partially by a perimeter line of disruption in the outer blank.

2. The carton of claim 1, wherein the latch further comprises a latch tab connected to the base portion, wherein the latch tab is not adhered to the inner blank.

3. The carton of claim 1 or claim 2, wherein the bottom panel comprises a plurality of overlapped single-ply flaps.

4. The carton of any one of claims 1 to 3, wherein the top panel comprises a plurality of overlapped single-ply flaps.

5. The carton of any one of claims 1 to 4, wherein the carton is substantially parallelepipedal.

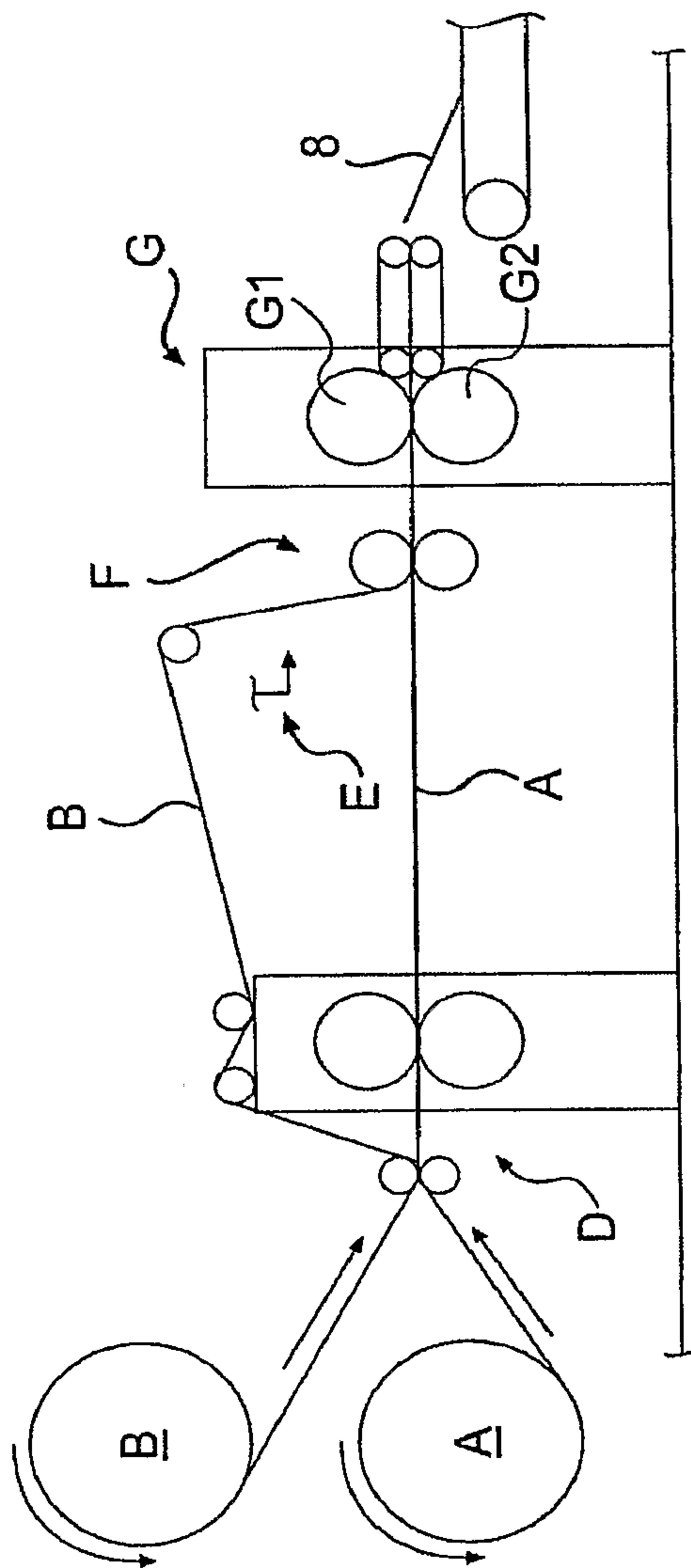

FIG. 1

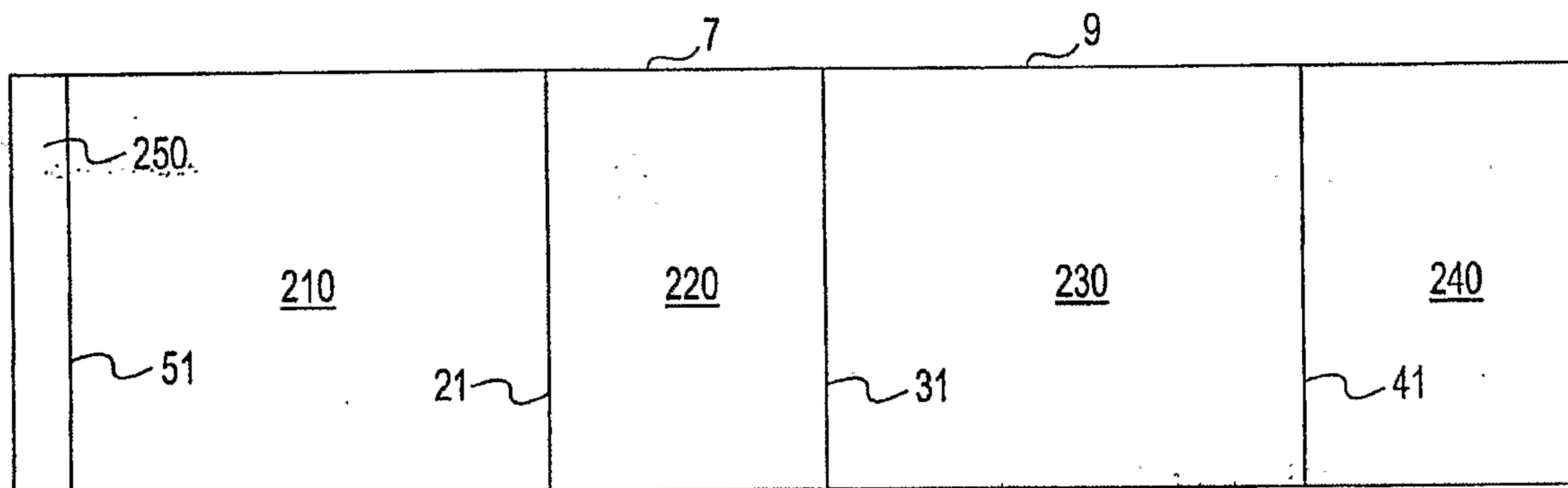

FIG. 2B

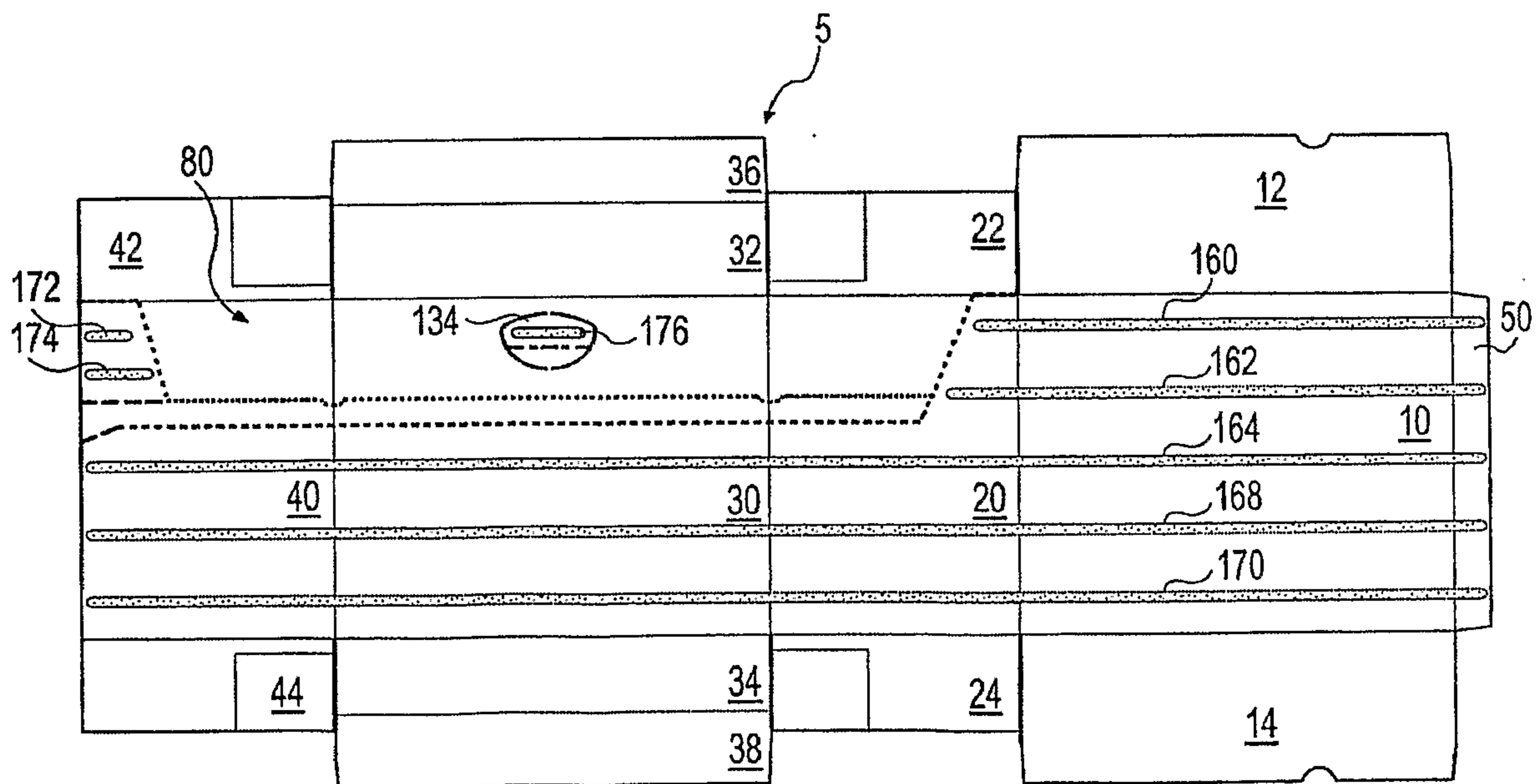

FIG. 3

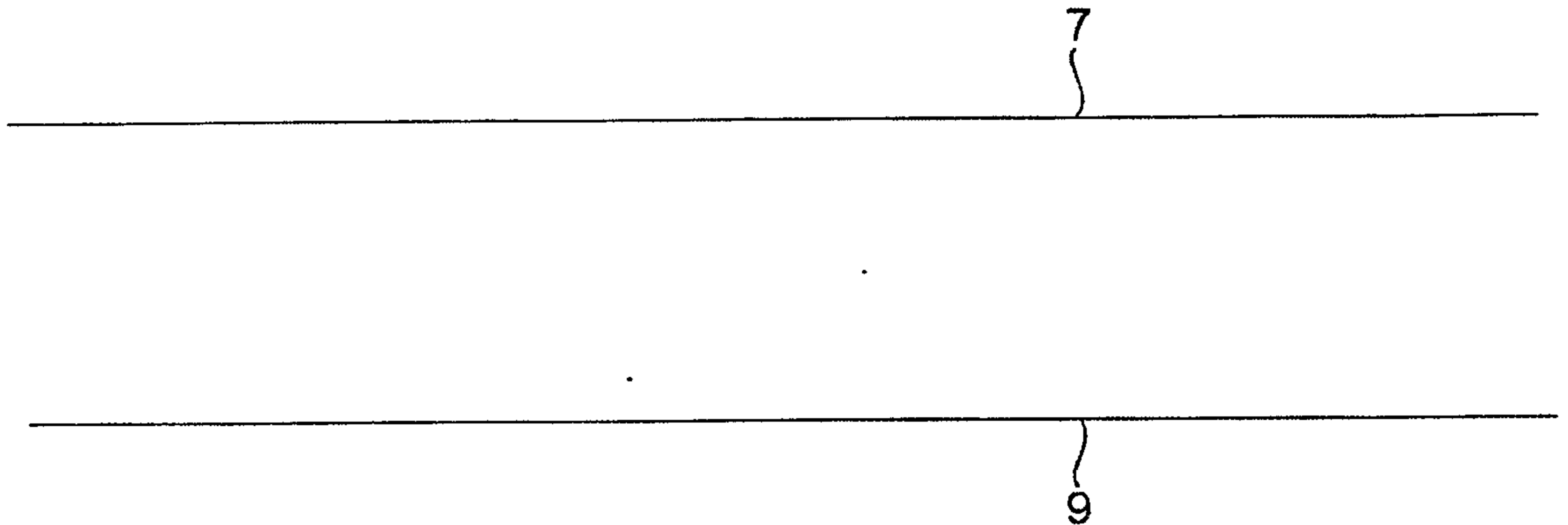

FIG. 4

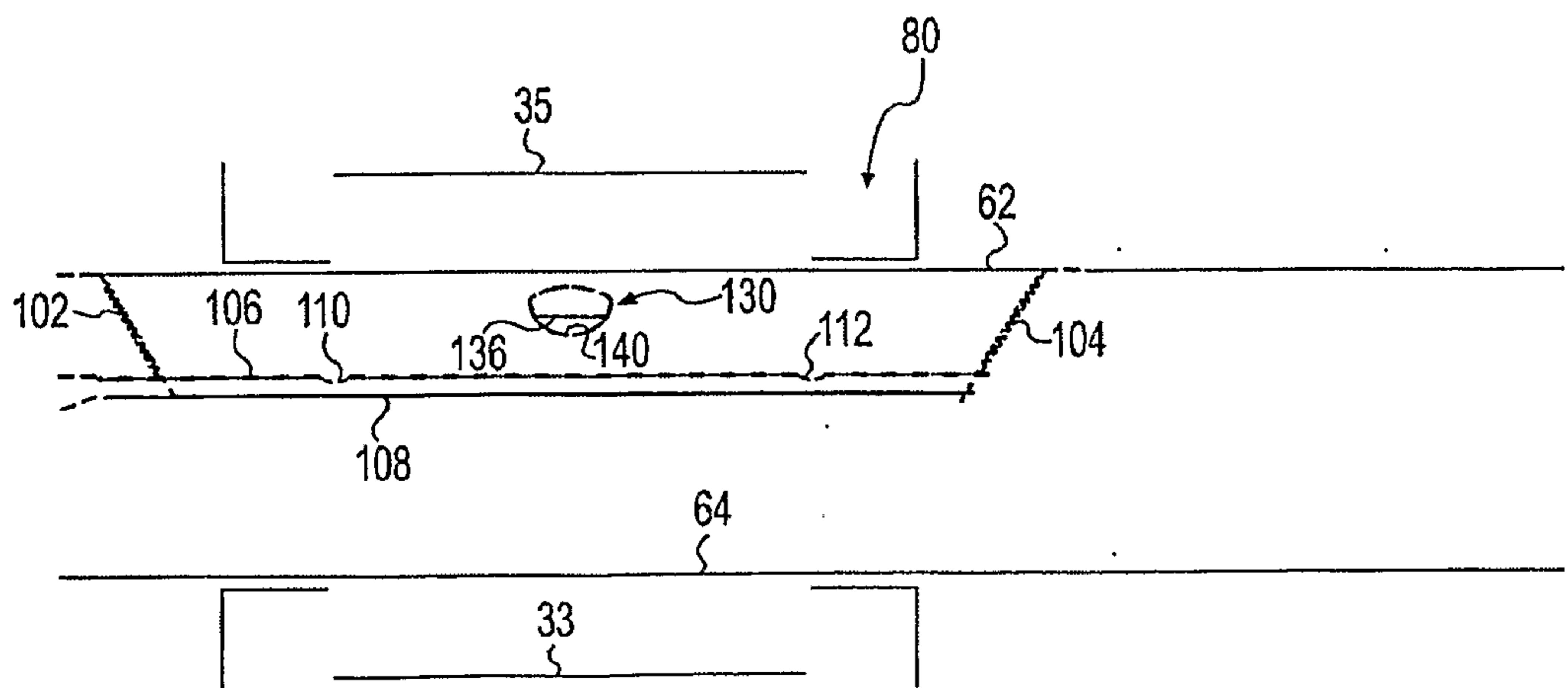

FIG. 5

5/9

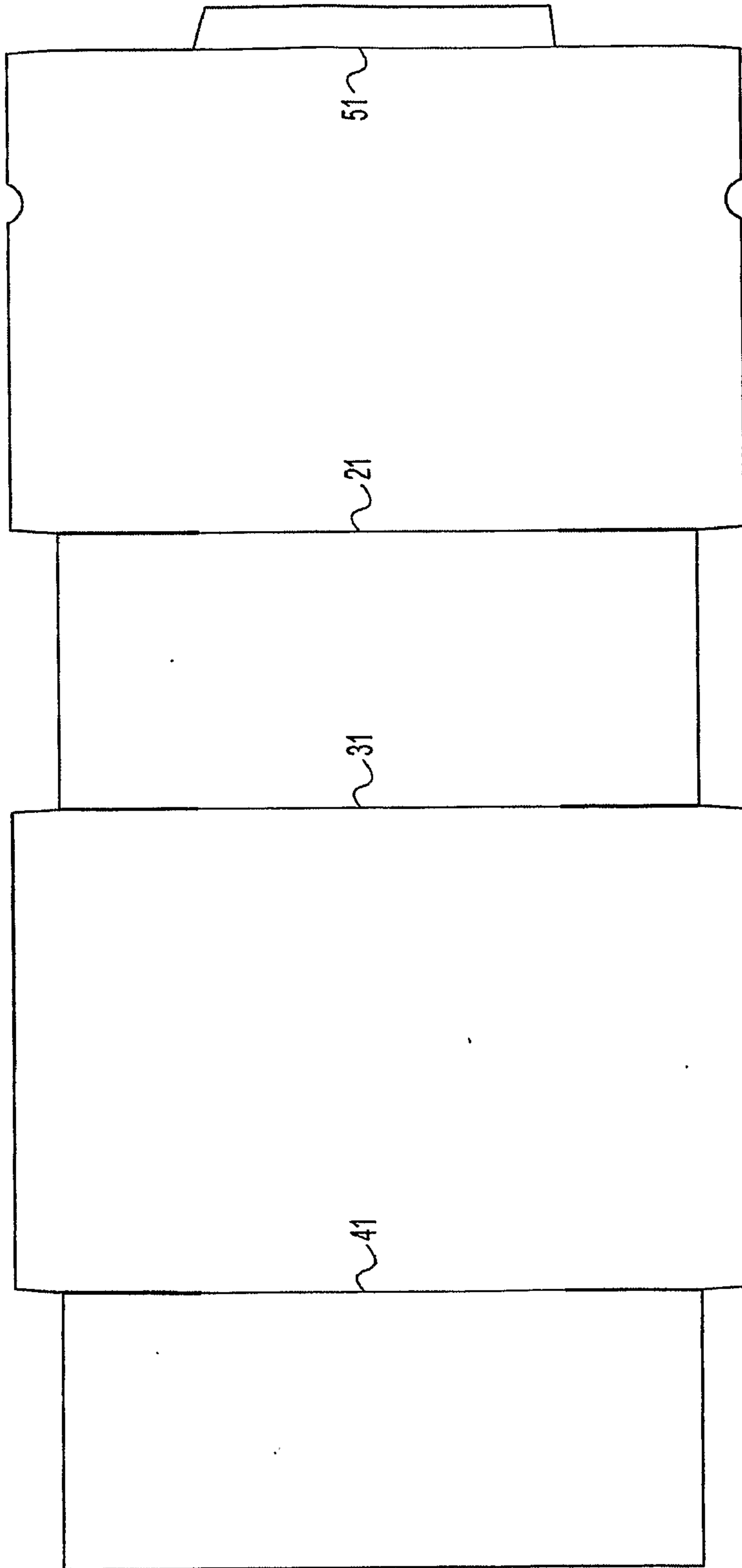

FIG. 6

190

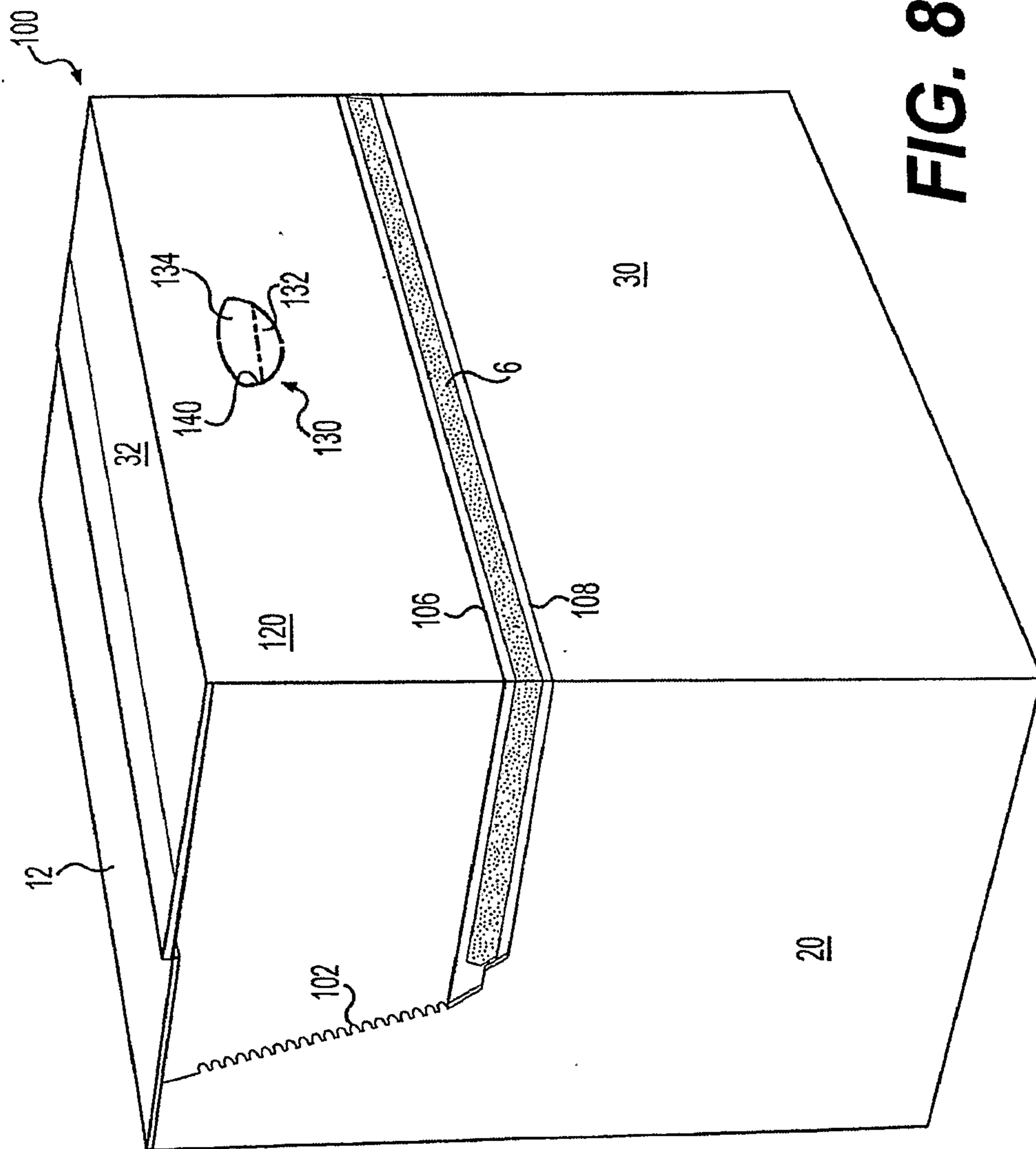

FIG. 8

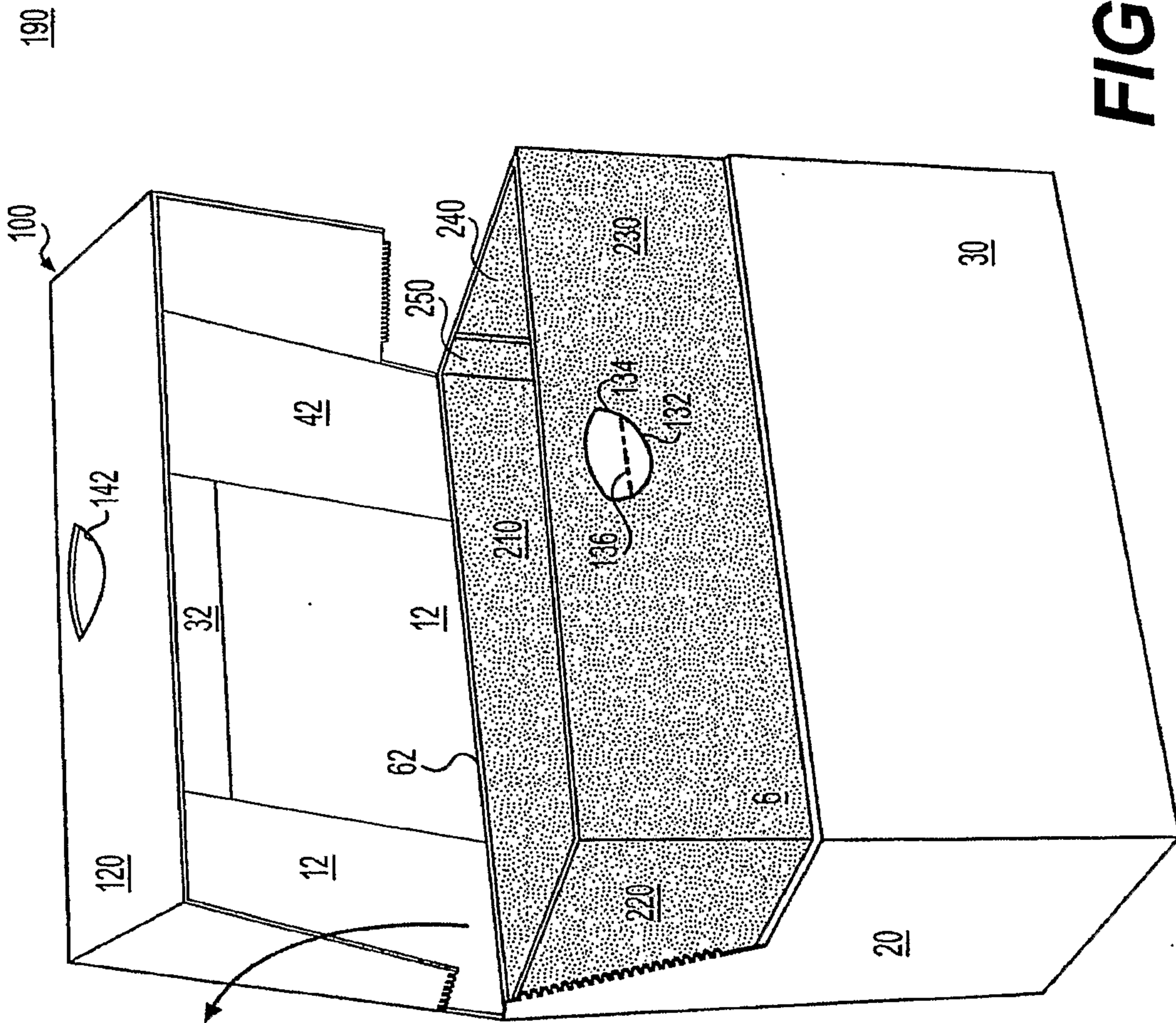

FIG. 9

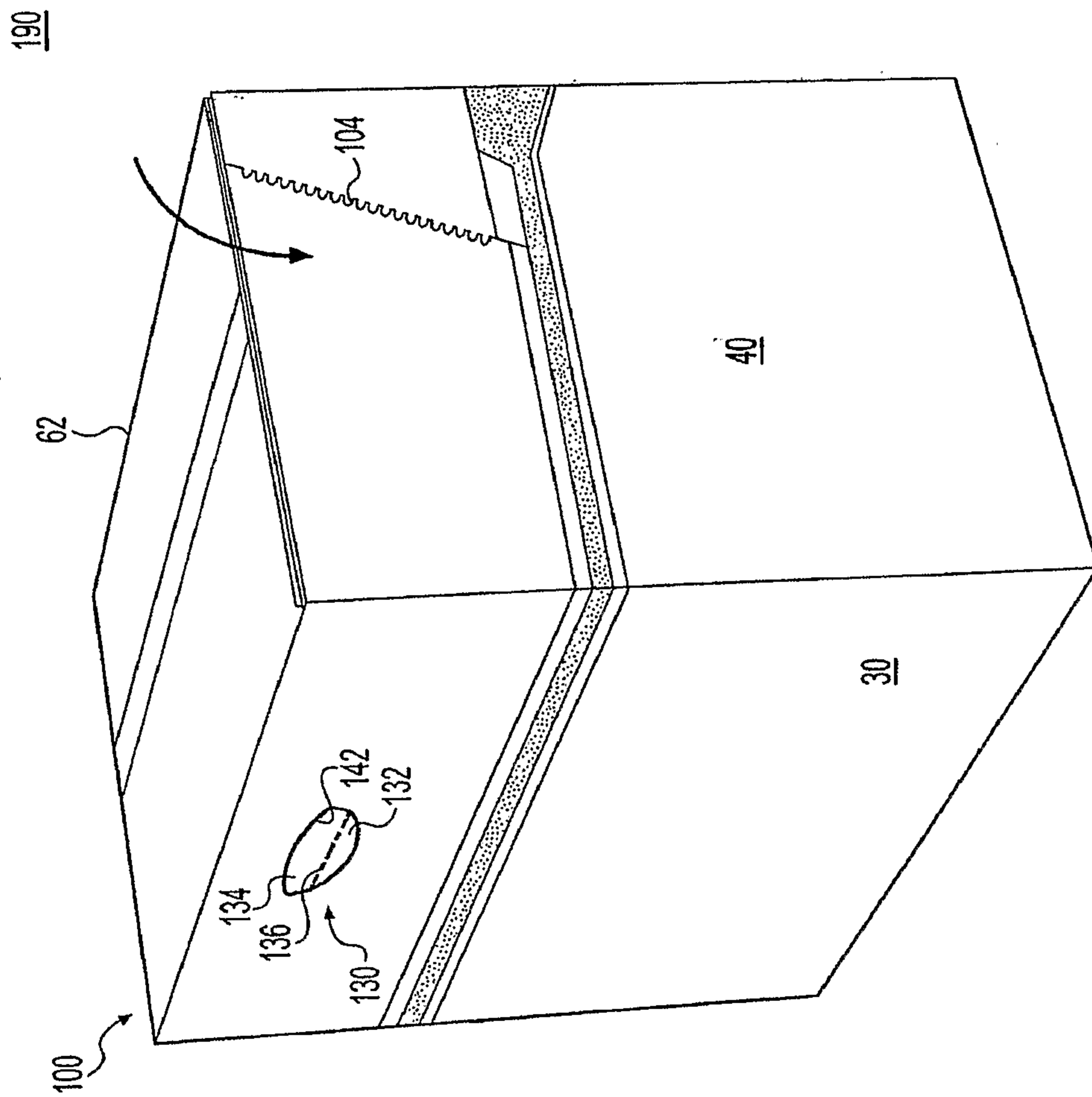

FIG. 10

