

C. L. Fitzhugh,

Horseshoe Blank Roll.

No. 110,349.

Patented Dec. 20, 1870.

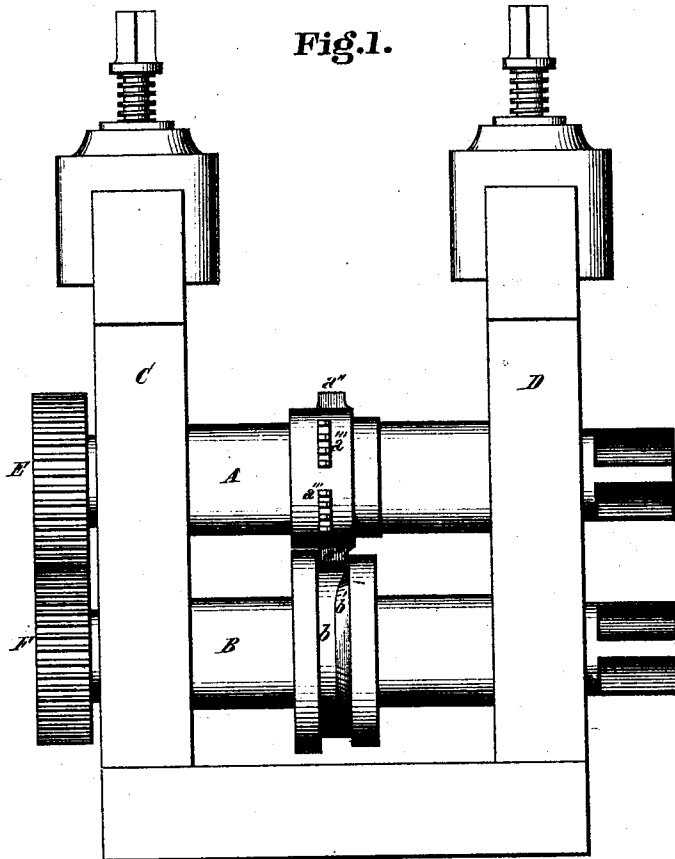

Fig. 2.

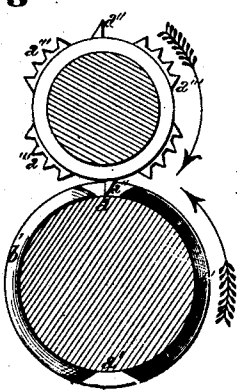
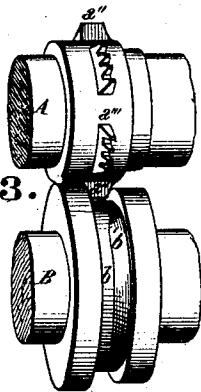

Fig. 3.



INVENTOR.

Charles L. Fitzhugh  
By F. Millward  
Attorney

Attest.

Edw. Lagman  
Henry Thillman

# United States Patent Office.

CHARLES L. FITZHUGH, OF PITTSBURG, PENNSYLVANIA.

Letters Patent No. 110,349, dated December 20, 1870.

## IMPROVEMENT IN ROLLS FOR FORMING HORSE-SHOE BLANKS.

The Schedule referred to in these Letters Patent and making part of the same.

### To all whom it may concern:

Be it known that I, CHARLES L. FITZHUGH, of Pittsburg, Allegheny county, State of Pennsylvania, have invented a certain improvement in Rolls for forming Horse-Shoe Blanks; and I do hereby declare the following to be a sufficiently full, clear, and exact description thereof to enable one skilled in the art to which my invention appertains to make and use it, reference being had to the accompanying drawing making part of this specification.

### Nature and Objects of Invention.

My invention is an improvement upon the horse-shoe rolls patented by William W. Lewis, February 1, 1859, reissued March 30, 1868, and consists in the provision in the said rolls of cutting-off knives, which, in connection with the devices embodied in the Letters Patent of W. W. Lewis, will completely prepare horse-shoe blanks for the bending-machine, and thus dispense with two costly operations heretofore necessary, viz., reheating and shearing.

### Description of the Accompanying Drawing.

Figure 1 is a side elevation of a pair of rolls in suitable housings, embodying my invention.

Figure 2 is a cross-section of the rolls, the section of the lower roll being taken through the groove, and that of the upper one through a plane near the housing.

Figure 3 is a perspective view of those portions of the rolls which form the blanks.

### General Description.

The rolls A B are journaled in the customary way, in bearings fitted to the housings O D, and are geared together by spur-wheels E F. The rolls are coupled to the motive-power in any of the known ways used in rolling-mills.

The lower roll B is formed with a groove, *b*, which, at the points *a a'*, is of the required size and shape of the heels of the blank, its other portions being formed with bevel projections *b'*, having curved ends, as shown.

These projections, when the rolls are in operation, form the peculiarly-shaped bevel necessary for the inside of the shoe when bent.

The roll A is constructed with projecting creasing-tongues *a''*, which are designed to form the nail-creases in the blank, and these creasers, *a''*, have serrated edges, as shown, by which the nail-holes are partially punched.

In addition to the construction of the rolls with groove-creasers and bevelers, all of which is found in the Letters Patent of William W. Lewis, aforesaid, I provide the roll A with two knives, *a' a'*, which are in such a position with relation to the roll B that they will cut the bar in the spaces *a a'*.

This provision of the knives not only serves to separate the iron into blanks of uniform length, but gives oblique ends to the blanks, which facilitates the formation of the heel-calks.

The knives *a'* can be connected to the body of the roll A by any preferred method.

Although I prefer the arrangement of the devices, as shown, it is obvious that the "creasers," "bevelers," and "knives" may be in either the upper or lower roll, or one or more of them in either roll, at will, and that the rolls can be constructed to form one, two, or more blanks at one revolution, according to the size of roll preferred and length of blank desired.

### Claim.

As an improvement on the machine patented as aforesaid to W. W. Lewis, the cutting-off knives *a'*, inserted in the roll for the purpose of cutting the rolled bar into suitable lengths for horse-shoe blanks while lying within the groove of the roll, as set forth.

In testimony of which invention I hereunto set my hand.

CHAS. L. FITZHUGH.

Witnesses:

JAS. E. MCKELVY,  
G. A. STEINER.