

Oct. 8, 1957

L. C. COBBETT

2,809,360

ARC-QUENCHING ELECTRICAL CONNECTOR

Filed Feb. 1, 1956

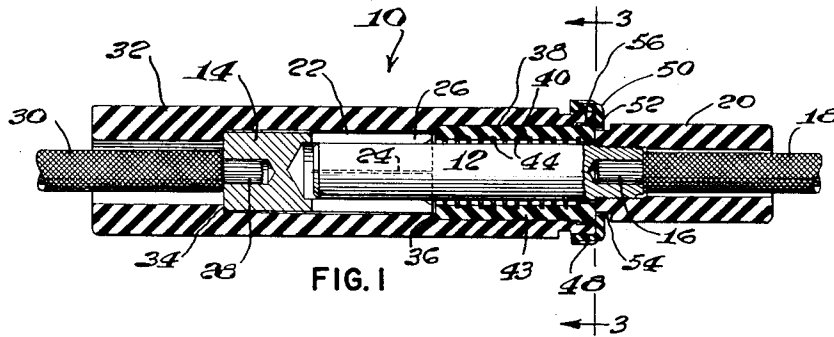

FIG. 1

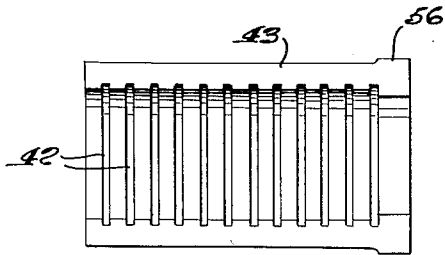

FIG. 2

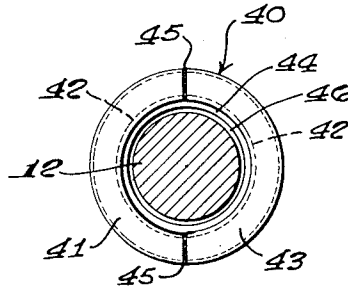

FIG. 3

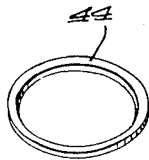

FIG. 4

INVENTOR.  
Leonard C. Cobbett  
BY  
*J. Stanley Churchill*  
ATTORNEY

1

2,809,360

## ARC-QUENCHING ELECTRICAL CONNECTOR

Leonard C. Cobbett, Foxboro, Mass., assignor to Albert & J. M. Anderson Manufacturing Company, Boston, Mass., a corporation of Massachusetts

Application February 1, 1956, Serial No. 562,839

3 Claims. (Cl. 339-111)

This invention relates to an electrical connector.

The invention has for an object to provide a novel and improved electrical connector having separable contact elements and in which provision is made for quenching in a simple and efficient manner the arc produced by separation of the contact elements.

With this general object in view and such others as may hereinafter appear, the invention consists in the electrical connector hereinafter described and particularly defined in the claims at the end of this specification.

In the drawings illustrating the preferred embodiment of the invention:

Fig. 1 is a cross sectional view of an electrical connector embodying the present invention;

Fig. 2 is a side elevation of one half section of a split insulating sleeve forming a part of the connector shown in Fig. 1;

Fig. 3 is an end view of the assembled insulating sleeve and showing a contact element in cross section as taken on the line 3-3 of Fig. 1; and

Fig. 4 is a perspective view of one of the metal rings shown in Figs. 1 and 3.

In general the present invention contemplates an electrical connector and more particularly an insulated electrical connector having separable contact elements and in which provision is made for quenching or suppressing the arc caused by separation of the contact elements to interrupt an electrical current. In the illustrated embodiment of the invention one of the contact elements is provided with an arc quenching chamber comprising a hollow insulating sleeve provided with a plurality of spaced metal elements, herein shown in the form of spaced metal rings supported in the insulating sleeve and arranged to surround the second contact element when the contacts are engaged. In operation upon separation of the contact elements, the quenching chamber effects a reduction in the length and duration of either alternating or direct current arcs produced when the elements are separated to interrupt an electric current. In practice it has been found that the provision of spaced metal rings supported within the quenching chamber and insulated from each other effects an increase in the voltage gradient along the arc produced upon separation of the contacts which in turn reduces the current flowing in the arc and thus permits more rapid cooling of the ionized gases.

Referring now to the drawings, the electrical connector indicated generally at 10 comprises a male contact element or metal plug 12 and a female contact element or metallic receptacle 14 adapted for longitudinal sliding engagement one within the other to provide an electrical connection. The plug contact 12 comprises an elongated rod cylindrical in cross section and having a bore 16 at its outer end for the reception of the bared end of an insulated cable 18, the bared end being soldered within the bore. The plug contact 12 is also provided with a tubular insulating handle 20 threadedly secured to the outer end

2

thereof, as shown, and through which the end of the cable 18 extends.

The receptacle contact 14 may comprise a cylindrical member substantially uniform diameter throughout its length, the engaging end of the contact having an elongated bore therein forming a tubular portion 22 provided with longitudinal saw cuts 24 to provide a receptacle having flexing fingers 26 for receiving the inner end of the plug contact 12. The other end of the receptacle contact 14 is provided with a small bore 28 into which the bared end of the second insulated cable 30 is soldered.

The receptacle contact 14 is provided with a hollow insulating housing 32 having stepped bores therein, an intermediate bored portion forming with the outer bore a shoulder 34 supporting the outer end of the receptacle contact with the cable 30 extending through the outer bore of the insulating housing as shown. The other end of the receptacle contact is arranged substantially flush with a second shoulder portion 36 provided by the larger bore 38 formed in the portion of the housing extending beyond the engaging end of the receptacle contact 14. The bore 38 is arranged to snugly receive an insulating sleeve 40 extended between the shoulder 36 and the extended end of the housing 32.

As herein shown, the insulating sleeve 40 is provided with a plurality of equally spaced annular grooves 42, each groove being arranged to support an annular metal ring 44, the inside diameter of the rings being of a size such that the rings extend a short distance into the bore or chamber defined by the insulating sleeve, and being of a size relative to the diameter of the plug 12 such as to provide a relatively small annular space 46 between the rings and the plug. As illustrated in Fig. 1, the extended end of the housing 32 is provided with a threaded portion 48 arranged to receive a threaded insulating cap 50 to enclose the insulating sleeve 40 within the housing, the cap member having a central opening 52 providing clearance for the plug contact 12 and a reduced diameter portion 54 of the plug handle 20. It will also be observed that the outer end of the bore 38 is of slightly enlarged diameter to receive a shouldered portion 56 of the insulating sleeve, and that the inside diameter of the sleeve 40 is slightly reduced at its outer end between the end ring and the adjacent end of the sleeve to provide a reduced annular space between the sleeve and the plug at this end, the reduced diameter of the sleeve being substantially equal to the inside diameters of the rings 44. As illustrated in Figs. 2 and 3, the insulating sleeve 40 is preferably made in two half sections 41, 43 which may be provided with corresponding grooves 42, the two half sections being cemented together, as indicated at 45, after assembly of the rings within the grooves as shown in Fig. 3.

From the description thus far it will be seen that in operation the elongated insulating sleeve 40 provided with the relatively closely spaced metal rings supported therein and insulated from each other by the intervening insulating material between adjacent spaced rings provides an arc quenching chamber which surrounds the plug contact 12 and through which the plug contact is withdrawn upon separation of the contacts to interrupt an electrical current. In practice the metal rings 44 may and preferably will comprise a relatively non-magnetic material and preferably of high electrical conductivity, such as brass rings, so that suppression of the arc is accomplished without resorting to electromagnetic forces. Other highly conductive and non-magnetic metals which may be used include copper or silver.

By way of example, the proportions and relative spacing of the various elements of the quenching chamber of a connector may be as follows: With a plug diameter

of  $\frac{7}{8}$  of an inch diameter, the rings 44 may be  $\frac{29}{32}$  inch inside diameter supported in grooves in an insulating sleeve having a one inch inside diameter. The rings may be about  $\frac{1}{16}$  of an inch in thickness, and the spacing between adjacent rings may be about  $\frac{1}{8}$  of an inch.

The contacts illustrated in the present embodiment of the invention are shown as cylindrical in form, and the quenching chamber is shown as provided with annular rings. However, it will be apparent that the invention may be adapted for use with separable contacts of other shapes with a correspondingly shaped quenching chamber. It will also be apparent that the present quenching device, illustrated as embodied in a single pole separable connector, may be readily adapted for use in a multipole connector.

From the above description it will be seen that in operation the highly conductive metal rings supported in spaced relation and insulated from each other in the arc quenching chamber are effective to reduce the length and duration of electric arcs produced when the plug is withdrawn from the receptacle. In effect, the spaced metal rings produce an increase in the voltage gradient along the arc which in turn reduces the current flowing in the arc and permits more rapid cooling of the ionized gases. In other words any arcs produced incident to separation of the contacts are broken up into a series of arcs which are rapidly deionized and extinguished as they move between the rings.

While the preferred embodiment of the invention has been herein illustrated and described it will be understood that the invention may be embodied in other forms within the scope of the following claims.

Having thus described the invention, what is claimed is:

1. An insulated electrical cable connector comprising an elongated outer insulating housing, a receptacle contact member provided with a plurality of elongated contact fingers and supported within one end of said housing and

having a cable connected thereto, an elongated plug contact member adapted to be manually engaged and disengaged extended within the other end of said elongated housing having its inner end telescopically engaged between said contact fingers and having a cable connected thereto, an arc quenching chamber comprising a tubular elongated sleeve supported within the plug contact end of said housing and occupying a space between the inner end of said receptacle contact member and the plug end of said outer housing, said tubular sleeve having a plurality of highly conductive metal rings supported in spaced grooves formed in the inner wall of said sleeve and separated by the intervening insulation between adjacent grooves, the inside diameter of the rings being less than the inside diameter of the sleeve and the cable contact member being of a diameter such as to provide a relatively small annular space between the plug contact member and the rings, said rings surrounding the end of the plug contact member as it is disengaged and withdrawn through said chamber to effect suppression of the arc produced by said disengagement.

2. An insulated electrical cable connector as defined in claim 1 which includes a hollow insulating screw cap member threadedly engaged with the plug end of said outer insulating housing for retaining said sleeve in assembled relation to said housing.

3. An insulated electrical cable connector as defined in claim 2 which includes a hollow insulating handle secured to the outer end of said plug contact member and through which the plug contact cable extends.

#### References Cited in the file of this patent

#### UNITED STATES PATENTS

35	1,486,893	Himes -----	Mar. 18, 1924
	2,611,846	Applegate -----	Sept. 23, 1952