

(19) **DANMARK**

(10) **DK/EP 2972046 T3**



(12) **Oversættelse af
europæisk patentskrift**

Patent- og
Varemærkestyrelsen

-
- (51) Int.Cl.: **F 28 F 3/08 (2006.01)** **F 24 F 12/00 (2006.01)** **F 28 D 9/00 (2006.01)**
F 28 D 21/00 (2006.01) **F 28 F 3/10 (2006.01)** **F 28 F 9/00 (2006.01)**
- (45) Oversættelsen bekendtgjort den: **2020-09-07**
- (80) Dato for Den Europæiske Patentmyndigheds bekendtgørelse om meddelelse af patentet: **2020-06-17**
- (86) Europæisk ansøgning nr.: **14765396.8**
- (86) Europæisk indleveringsdag: **2014-03-04**
- (87) Den europæiske ansøgnings publiceringsdag: **2016-01-20**
- (86) International ansøgning nr.: **CA2014000171**
- (87) Internationalt publikationsnr.: **WO2014138860**
- (30) Prioritet: **2013-03-14 US 201361783048 P** **2014-02-26 US 201414190715**
- (84) Designerede stater: **AL AT BE BG CH CY CZ DE DK EE ES FI FR GB GR HR HU IE IS IT LI LT LU LV MC MK MT NL NO PL PT RO RS SE SI SK SM TR**
- (73) Patenthaver: **Nortek Air Solutions Canada, Inc., 1502 D. Quebec Ave, Saskatoon, SK S7K 1V7, Canada**
- (72) Opfinder: **ERB, Blake Norman, 302 Faldo Cres., Warman, Saskatchewan S0K 4S1, Canada**
HANSON, Stephen, 113 - 320 Heritage Cr., Saskatoon, Saskatchewan S7H 5P4, Canada
AFSHIN, Mohammad, 1030 9th St., Saskatoon, Saskatchewan S7H 0N2, Canada
- (74) Fuldmægtig i Danmark: **Plougmann Vingtoft A/S, Strandvejen 70, 2900 Hellerup, Danmark**
- (54) Benævnelse: **MEMBRAN-INTEGRERET ENERGIUDVEKSLINGSANORDNING**
- (56) Fremdragne publikationer:
EP-A2- 0 448 991
WO-A1-2004/065875
WO-A2-2011/161547
CH-A- 193 732
GB-A- 1 354 502
JP-A- H10 170 177
US-A1- 2009 294 110

DESCRIPTION

BACKGROUND OF THE DISCLOSURE

[0001] Embodiments of the present disclosure generally relate to an energy exchange assembly, and, more particularly, to an energy exchange assembly having one or more membranes that are configured to transfer sensible and/or latent energy therethrough.

[0002] Energy exchange assemblies are used to transfer energy, such as sensible and/or latent energy, between fluid streams. For example, air-to-air energy recovery cores are used in heating, ventilation, and air conditioning (HVAC) applications to transfer heat (sensible energy) and moisture (latent energy) between two airstreams. A typical energy recovery core is configured to precondition outdoor air to a desired condition through the use of air that is exhausted out of the building. For example, outside air is channeled through the assembly in proximity to exhaust air. Energy between the supply and exhaust air streams is transferred therebetween. In the winter, for example, cool and dry outside air is warmed and humidified through energy transfer with the warm and moist exhaust air. As such, the sensible and latent energy of the outside air is increased, while the sensible and latent energy of the exhaust air is decreased. The assembly typically reduces post-conditioning of the supply air before it enters the building, thereby reducing overall energy use of the system.

[0003] Energy exchange assemblies such as air-to-air recovery cores may include one or more membranes through which heat and moisture are transferred between air streams. Each membrane may be separated from adjacent membranes using a spacer. Stacked membrane layers separated by spacers form channels that allow air streams to pass through the assembly. For example, outdoor air that is to be conditioned may enter one side of the device, while air used to condition the outdoor air (such as exhaust air or scavenger air) enters another side of the device. Heat and moisture are transferred between the two airstreams through the membrane layers. As such, conditioned supply air may be supplied to an enclosed structure, while exhaust air may be discharged to an outside environment, or returned elsewhere in the building.

[0004] In an energy recovery core, for example, the amount of heat transferred is generally determined by a temperature difference and convective heat transfer coefficient of the two air streams, as well as the material properties of the membrane. The amount of moisture transferred in the core is generally governed by a humidity difference and convective mass transfer coefficients of the two air streams, but also depends on the material properties of the membrane.

[0005] Many known energy recovery assemblies that include membranes are assembled by either wrapping the membrane or by gluing the membrane to a substrate. Notably, the design and assembly of an energy recovery assembly may affect the heat and moisture transfer

between air streams, which impacts the performance and cost of the device. For example, if the membrane does not properly adhere to the spacer, an increase in air leakage and pressure drop may occur, thereby decreasing the performance (measured as latent effectiveness) of the energy recovery core. Conversely, if excessive adhesive is used to secure the membrane to the spacer, the area available for heat and moisture transfer may be reduced, thereby limiting or otherwise reducing the performance of the energy recovery core. Moreover, the use of adhesives in relation to the membrane also adds additional cost and labor during assembly of the core. Further, the use of adhesives may result in harmful volatile organic compounds (VOCs) being emitted during initial use of an energy recovery assembly.

[0006] While energy recovery assemblies formed through wrapping techniques may reduce cost and minimize membrane waste, the processes of manufacturing such assemblies are typically labor intensive and/or use specialized automated equipment. The wrapping may also result in leaks at edges due to faulty seals. For example, gaps typically exist between membrane layers at corners of an energy recovery assembly. Further, at least some known wrapping techniques result in a seam being formed that extends along membrane layers. Typically, the seam is sealed using tape, which blocks pore structures of the membranes, and reduces the amount of moisture transfer in the assembly.

CH193732A discloses an apparatus for bringing liquid media in contact with walls for executing an isobaric thermodynamic phase change.

GB1354502 discloses heat exchangers for transferring heat between fluids through thin walled members.

US20090294110 discloses a brazed aluminum counter-flow heat exchanger.

SUMMARY OF THE DISCLOSURE

[0007] According to the present invention there is provided a membrane panel assembly according to claim 1, an energy exchange assembly according to claim 12, and a method of forming a membrane panel assembly according to claim 15.

[0008] Embodiments of the present disclosure provide energy exchange assemblies having one or more membranes that are directly integrated with an outer frame. Embodiments of the present disclosure may be formed without adhesives or wrapping.

[0009] Certain embodiments of the present disclosure provide a membrane panel configured to be secured within an energy exchange assembly. The membrane panel includes an outer frame defining a central opening, and a membrane sheet integrated with the outer frame. The membrane sheet spans across the central opening, and is configured to transfer one or both of sensible energy or latent energy therethrough. The membrane sheet may be integrated with the outer frame without an adhesive.

[0010] The outer frame may be injection-molded around edge portions of the membrane sheet. Alternatively, the membrane sheet may be ultrasonically bonded to the outer frame. In

at least one other embodiment, the membrane sheet may be laser-bonded to the outer frame. In at least one other embodiment, the membrane sheet may be heat-sealed to the outer frame.

[0011] The outer frame may include a plurality of brackets having inner edges that define the central opening. One or more spacer-securing features, such as recesses, divots, slots, slits, tabs, or the like, may be formed through or in at least one of the inner edges. In at least one embodiment, the outer frame may include a plurality of upstanding corners.

[0012] In at least one embodiment, the outer frame fits together with at least one separate membrane spacer to form at least one airflow channel. In at least one embodiment, the outer frame may be integrally molded and formed with at least one membrane spacer.

[0013] Certain embodiments of the present disclosure provide an energy exchange assembly that may include a plurality of membrane spacers, and a plurality of membrane panels. Each of the plurality of membrane panels may include an outer frame defining a central opening defining a fluid channel, and a membrane sheet integrated with the outer frame. The membrane sheet spans across the central opening, and is configured to transfer one or both of sensible energy or latent energy therethrough. Each of the plurality of membrane spacers is positioned between two of the plurality of membrane panels.

[0014] In at least one embodiment, the plurality of membrane panels includes a first group of membrane panels and a second group of membrane panels. The first group of membrane panels may be orthogonally oriented with respect to the second group of membrane panels.

[0015] In at least one embodiment, each of the plurality of membrane spacers may include a connecting bracket having a reciprocal shape to the plurality of upstanding corners. The outer frame may include at least one sloped connecting bracket configured to mate with a reciprocal feature of one of the plurality of spacers. The plurality of spacers and the plurality of membrane panels may form stacked layers.

[0016] Certain embodiments of the present disclosure provide a method of forming a membrane panel configured to be secured within an energy exchange assembly. The method may include forming an outer frame defining a central opening, and integrating a membrane sheet with the outer frame. The membrane sheet spans across the central opening, and is configured to transfer one or both of sensible energy or latent energy therethrough.

[0017] The integrating operation may include injection-molding the outer frame around edge portions of the membrane sheet. In at least one other embodiment, the integrating operation includes ultrasonically bonding the membrane sheet to the outer frame. In at least one other embodiment, the integrating operation comprises laser-bonding the membrane sheet to the outer frame. In at least one other embodiment, the integrating operation includes heat-sealing the membrane sheet to the outer frame. The integrating operation may be performed without the use of an adhesive, such as glue, tape, or the like.

BRIEF DESCRIPTION OF THE DRAWINGS**[0018]**

Figure 1 illustrates a perspective top view of a membrane panel, according to an example which does not form part of the invention.

Figure 2 illustrates a top plan view of an outer frame of a membrane panel, according to an example which does not form part of the invention.

Figure 3 illustrates a perspective top view of a membrane spacer, according to an example which does not form part of the invention.

Figure 4 illustrates a perspective exploded top view of a membrane stack, according to an example which does not form part of the invention.

Figure 5 illustrates a perspective top view of an energy exchange assembly, according to an embodiment of the present disclosure.

Figure 6 illustrates a perspective top view of an outer casing being positioned on an energy exchange assembly, according to an embodiment of the present disclosure.

Figure 7 illustrates a perspective top view of an energy exchange assembly having an outer casing, according to an embodiment of the present disclosure.

Figure 8 illustrates a perspective top view of a stacking frame, according to an embodiment of the present disclosure.

Figure 9 illustrates a perspective top view of an energy exchange assembly having multiple membrane stacks secured within a stacking frame, according to an embodiment of the present disclosure.

Figure 10 illustrates a perspective top view of an outer frame of a membrane panel, according to an embodiment of the present disclosure.

Figure 11 illustrates a corner view of an outer frame of a membrane panel, according to an embodiment of the present disclosure.

Figure 12 illustrates a perspective top view of a membrane panel, according to an embodiment of the present disclosure.

Figure 13 illustrates a perspective top view of a membrane sheet secured to a corner of an outer frame of a membrane panel, according to an embodiment of the present disclosure.

Figure 14 illustrates a perspective top view of a membrane spacer, according to an embodiment of the present disclosure.

Figure 15 illustrates a lateral view of a stacking connecting bracket of a membrane spacer, according to an embodiment of the present disclosure.

Figure 16 illustrates a perspective exploded top view of a membrane stack, according to an embodiment of the present disclosure.

Figure 17 illustrates a perspective top view of an outer frame of a membrane panel, according to an embodiment of the present disclosure.

Figure 18 illustrates a perspective top view of a corner of an outer frame of a membrane panel, according to an embodiment of the present disclosure.

Figure 19 illustrates a lateral view of a stacking connecting bracket of a membrane spacer, according to an embodiment of the present disclosure.

Figure 20 illustrates a simplified schematic view of an energy exchange system operatively connected to an enclosed structure, according to an embodiment of the present disclosure.

Figure 21 illustrates a simplified cross-sectional view of a mold configured to form a membrane panel, according to an embodiment of the present disclosure.

Figure 22 illustrates a simplified representation of a membrane sheet being integrated with an outer frame of a membrane panel, according to an embodiment of the present disclosure.

Figure 23 illustrates a lateral view of a connecting bracket of a membrane spacer, according to an embodiment of the present disclosure.

Figure 24 illustrates a flow chart of a method of forming a membrane panel, according to an embodiment of the present disclosure.

DETAILED DESCRIPTION OF THE DISCLOSURE

[0019] The foregoing summary, as well as the following detailed description of certain embodiments will be better understood when read in conjunction with the appended drawings. As used herein, an element or step recited in the singular and proceeded with the word "a" or "an" should be understood as not excluding plural of the elements or steps, unless such exclusion is explicitly stated. Further, references to "one embodiment" are not intended to be interpreted as excluding the existence of additional embodiments that also incorporate the recited features. Moreover, unless explicitly stated to the contrary, embodiments "comprising" or "having" an element or a plurality of elements having a particular property may include additional elements not having that property.

[0020] Figure 1 illustrates a perspective top view of a membrane panel 100. The membrane panel 100 may be used in an energy exchange assembly, such as an energy recovery core,

membrane heat exchanger, or the like. For example, a plurality of membrane panels 100 may be stacked to form an energy exchange assembly.

[0021] The membrane panel 100 includes an outer frame 101 that integrally retains a membrane sheet 102. The membrane sheet 102 is integrated with the membrane panel 100. The outer frame 101 may have a quadrilateral shape that defines a similarly shaped opening that receives and retains the membrane sheet 102. For example, the outer frame 101 may include end brackets 104 that are integrally connected to lateral brackets 106. The end brackets 104 may be parallel with one another and perpendicular to the lateral brackets 106. The opening may be defined by the end brackets 104 and the lateral brackets 106, which combine to provide four linear frame segments. In at least one embodiment, the area of the opening may be slightly less than the area defined by the end brackets 104 and the lateral brackets 106, thereby maximizing an area configured to transfer energy. The outer frame 101 may be formed of a plastic or a composite material. Alternatively, the outer frame 101 may be formed of various other shapes and sizes, such as triangular or round shapes.

[0022] Each of the end brackets 104 and the lateral brackets 106 may have the same or similar shape, size, and features. For example, each bracket 104 or 106 may include a planar main rectangular body 108 having opposed planar upper and lower surfaces 110 and 112, respectively, end edges 114, and opposed outer and inner edges 116 and 118, respectively. One or more spacer-securing features 120, such as recesses, divots, slots, slits, or the like, may be formed through or within the inner edge 118. The spacer-securing features 120 may be formed through one or both of the upper and lower surfaces 110 and 112. The spacer-securing features 120 may provide alignment slots configured to align the membrane panel 100 with a membrane spacer. For example, the spacer-securing features 120 may be grooves linearly or irregularly spaced along the inner edges 118 of the brackets 104 and 106, while the membrane spacer includes protuberances, such as tabs, barbs, studs, or the like, that are configured to be received and retained within the spacer-securing features 120. Alternatively, the spacer-securing features 120 may be protuberances, while the membrane spacer includes the grooves, for example.

[0023] Figure 2 illustrates a top plan view of the outer frame 101 of the membrane panel 100. The membrane sheet 102 (shown in Figure 1) is not shown in Figure 2. As shown in Figure 1, the outer frame 101 defines an opening 122 into which the membrane sheet 102 is secured. Terminal ends 123 of the end brackets 104 overlay terminal ends 124 of the lateral brackets 106. The end brackets 104 may be secured to the lateral brackets 106 through fasteners, adhesives, bonding, and/or the like. For example, each bracket 104 and 106 may be separately positioned and secured to form the unitary outer frame 101. Alternatively, the outer frame 101 may be integrally molded and formed as shown such as through injection-molding, for example. That is, the outer frame 101 may be a unitary, integrally molded and form piece.

[0024] As shown in Figure 1, in particular, the end brackets 104 are positioned over the lateral brackets 106 such that an air channel 126 is defined between inner edges 116 of the opposed lateral brackets 106, while an air channel 128 is defined between inner edges 116 of the

opposed end brackets 104. The air channel 126 is configured to allow an air stream 130 to pass therethrough below the membrane sheet 102 (as shown in Figure 1), while the air channel 128 is configured to allow an air stream 132 to pass therethrough above the membrane sheet 102. As shown, the outer frame 102 may be formed so that the air channels 126 and 128 are perpendicular to one another. For example, the air channel 128 may be aligned parallel to an X axis, while the air channel 126 may be aligned parallel with a Y axis, which is orthogonal to the X axis.

[0025] Referring again to Figure 1, the membrane sheet 102 may be a thin, porous, semi-permeable membrane. The membrane sheet 102 may be formed of a microporous material. For example, the membrane sheet 102 may be formed of polytetrafluoroethylene (PTFE), polypropylene (PP), nylon, polyvinylidene fluoride (PVDF), polyethersulfone (PES), or the like. The membrane sheet 102 may be hydrophilic or hydrophobic. The membrane sheet 102 may have the same length and width (for example, the same dimensions in at least one plane) as the outer frame 101. For example, the membrane sheet 102 may include a thin, moisture/vapor-promoting polymer film that is coated on a porous polymer substrate. In another example, the membrane sheet 102 may include a hygroscopic coating that is bonded to a resin or paper-like substrate material.

[0026] Alternatively, the membrane sheet 102 may not be porous. For example, the membrane sheet 102 may be formed of a non-porous plastic sheet that is configured to transfer heat, but not moisture, therethrough.

[0027] During assembly of the membrane panel 100, the membrane sheet 102 may be integrally formed and/or molded with the outer frame 101. For example, the membrane sheet 102 may be integrated and/or integrally formed with the frame 101 through a process of injection-molding. For example, an injection mold may be sized and shaped to form the membrane panel 100. Membrane material may be positioned within the mold and panel material, such as plastic, may be injected into the mold on and/or around portions of the membrane material to form the integral membrane panel 100. Alternatively, the membrane material may be injected into the mold, as opposed to a membrane sheet being positioned within the mold. In such embodiments, the membrane sheet 102 may be integrally formed and molded with the plastic of the outer frame 101. In at least one embodiment, the material that forms the outer frame 101 may also form the membrane sheet 102.

[0028] As an example, the membrane sheet 102 may be positioned within a mold that is configured to form the membrane panel 100. Hot, liquid plastic is injected into the mold and flows on and/or around portions of the membrane sheet 102. As the plastic cools and hardens to form the outer frame 101, the plastic securely fixes to edge portions of the membrane sheet 102. For example, during the injection molding, the hot, liquid plastic may melt into the membrane sheet 102, thereby securely fastening the outer frame 101 to the membrane sheet 102.

[0029] Accordingly, the membrane panel 100, including the membrane sheet 102 and the

outer frame 101, may be formed in a single step, thereby providing an efficient assembly process.

[0030] Alternatively, the membrane sheet 102 may be integrated and/or integrally formed with the outer frame 101 through heat-sealing, ultrasonic bonding or welding, laser-bonding, or the like. For example, when the membrane panel 100 is formed through ultrasonic welding, ultrasonic vibrational energy may be focused into a specific interface area between the membrane sheet 102 and the outer frame 101, thereby securely welding, bonding, or otherwise securely connecting the membrane sheet 102 to the outer frame 101. In at least one embodiment, a ridge may extend over and/or around the outer frame 101. The membrane sheet 102 may be positioned on the outer frame 101, and the ultrasonic energy may be focused into the interface between the membrane sheet 102 and the ridge.

[0031] In at least one other embodiment, laser-bonding may be used to integrate the membrane sheet 102 into the outer frame 101. For example, a laser may be used to melt portions of the membrane sheet 102 into portions of the outer frame 101, or vice versa. The heat of the laser melts the membrane sheet 102 and/or the outer frame 101 to one another, thereby providing a secure connection therebetween. Alternatively, thermal plate bonding may be used to melt portions of the membrane sheet 102 and the outer frame 101 together.

[0032] The membrane sheet 102 may be integrally secured to lower surfaces 112 of the end brackets 104 and upper surfaces 110 of the lateral brackets 106, or vice versa. Once integrated with the outer frame 102, the membrane sheet 102 spans over and/or through the entire area of the opening 122 (shown in Figure 2), and the membrane sheet 102 is sealed to the outer frame 102 along the entire perimeter defined by the lower surfaces 112 of the end brackets 104 and the upper surfaces 110 of the lateral brackets 106. Therefore, the membrane sheet 102 may be integrated or integrally formed with the outer frame 101 without using any adhesives (such as glues, tapes, or the like) or wrapping techniques. Embodiments of the present disclosure provide membrane panels having integrated or integral membrane sheets secured to outer frames without adhesives.

[0033] Optionally, the membrane panel 100 may include a sealing layer 140, which may be formed of a compressible material, such as foam. Alternatively, the sealing layer 140 may be a sealing gasket, for example. Also, alternatively, the sealing layer 140 may be a silicone or an adhesive. In at least one embodiment, the sealing layer 140 may include two strips 142 of sealant located along opposing frame segments, such as the end brackets 104.

[0034] Figure 3 illustrates a perspective top view of a membrane or air spacer 200. The spacer 200 may be used with the membrane panel 100 shown in Figure 1. The spacer 200 may be formed as a rectangular grid of rails 202 and reinforcing beams 204. For example, the rails 202 may each extend along the entire length L of the spacer 200, and the reinforcing beams 204 may fix each rail 202 to the adjacent rails 202. As shown in Figure 3, the reinforcing beams 204 may be oriented perpendicularly to the rails 202 to form a checkerboard grid pattern. Optionally, the height of the spacer 200 may be the height H of the rails 202. Thus,

when the spacers 200 are placed between the panels 100 (shown in Figure 1), the space between the panels 100 may be the height H. The rails 202 may be oriented such that the height H of each rail is greater than the width W, as shown in Figure 3. The width W may be less than a distance D between adjacent rails 202 in order to maximize air flow through the spacer 200. Air through the spacer 200 may be configured to flow through channels 206 located between the rails 202.

[0035] The spacer 200 may include alignment tabs 208 that extend outwardly along the length of the outermost rails 202'. The alignment tabs 208 may be configured to be received in the spacer-securing features 120 of the membrane panels 100 (shown in Figures 1 and 2) for proper alignment of the membrane panels 100 relative to the spacer 200. For example, the alignment tabs 208 may be configured to be received in the spacer-securing features 120, such as slot, divots, or the like, of the membrane panel 100 located above the spacer 200, the membrane panel 100 located below the spacer 200, or both.

[0036] Referring to Figures 1-3, various types of spacers other than shown in Figure 3 may be used to space the membrane panels 100 from one another. For example, United States Patent Application No. 13/797,062, filed March 12, 2013, entitled "Membrane Support Assembly for an Energy Exchanger," which is hereby incorporated by reference in its entirety, describes various types of membrane spacers or support assemblies that may be used in conjunction with the membrane panels described with respect to the present application.

[0037] Figure 4 illustrates a perspective exploded top view of a membrane stack 300. The stack 300 may include an air or membrane spacer 200 between two panels 100. For example, an energy exchange assembly may be assembled by stacking alternating layers of panels 100 and spacers 200 into the stack 300. As shown, the spacer 200 may be mounted on top of a lower panel 100a, such that the alignment tabs 208 are received and retained in the spacer-securing features 120 of the panel 100a. Additional sealing between layers may be achieved with the sealing layer 140, which may be injection-molded or attached onto the outer frame 102, for example.

[0038] An upper membrane panel 100b may be subsequently mounted on top of the spacer 200. Optionally, the upper membrane panel 100b may be rotated 90° with respect to the lower panel 100a upon mounting. Continuing the stacking pattern shown, an additional spacer (not shown) may be added above the upper panel 100b and aligns with the upper panel 100b such that a subsequent spacer may be rotated 90° relative to the spacer 200. Consequently, the channels 206 through the spacer 200 may be orthogonal to the channels (not shown) through the adjacent spacer, so that air flows through the channels 206 of the spacer 200 in a cross-flow direction relative to the air through the channels of the adjacent spacer. Alternatively, the membrane panels 100 and the spacers 200 may be arranged to support various fluid flow orientations, such as counter-flow, concurrent flow, and the like.

[0039] Figure 5 illustrates a perspective top view of an energy exchange assembly 400, such as an energy recovery core, membrane heat exchanger, or the like, according to an

embodiment of the present disclosure. The energy exchange assembly 400 may include a stack of multiple layers 402 of membrane panels 100 and spacers 200. As shown, the energy exchange assembly 400 may be a cross-flow, air-to-air membrane energy recovery core. During operation, a first fluid stream 403, such as air or other gas(es), enters the energy exchange assembly 400 through channels 206a defined within a first wall 406 of the assembly 400. The wall 406 may be defined, at least in part, by the outer edges of the outer frames 102 of the membrane panels 100 in the stack. Similarly, a second fluid stream 404, such as air or other gas(es), enters the assembly 400 through channels 206b defined within a second wall 408 of the assembly 400.

[0040] The first fluid stream 403 direction may be perpendicular to the second fluid stream 404 direction through the assembly 400. As shown, the spacers 200 may be alternately positioned 90° relative to one another, so that the channels 206b are orthogonal to the channels 206a. Consequently, the fluid stream 403 through the assembly 400 is surrounded above and below by membrane sheets 102 (shown in Figure 1, for example) that form borders separating the fluid stream 403 from the fluid stream 404, and vice versa. Thus, energy, in the form heat and/or humidity, may be exchanged through the membrane sheets 102 from the higher energy/temperature fluid flow to the lower energy/temperature fluid flow, for example.

[0041] The energy exchange assembly 400 may be oriented so that the fluid stream 403 may be outside air that is to be conditioned, while the second fluid stream 404 may be exhaust, return, or scavenger air that is used to condition the outside air before the outside air is supplied to downstream HVAC equipment and/or an enclosed space as supply air. Heat and moisture may be transferred between the first and second fluid streams 403 and 404 through the membrane sheets 102 (shown in Figure 1, for example).

[0042] As shown, the membrane panels 100 may be secured between outer upstanding beams 410. As shown, the beams 410 may generally be at the corners of the energy exchange assembly 400. Alternatively, the energy exchange assembly 400 may not include the beams 410. Instead, the energy exchange assembly 400 may be formed through a stack of multiple membrane panels 100.

[0043] As an example of operation, the first fluid stream 403 may enter an inlet side 412 as cool, dry air. As the first fluid stream 403 passes through the energy exchange assembly 400, the temperature and humidity of the first fluid stream 403 are both increased through energy transfer with the second fluid stream 404 that enters the energy exchange assembly 400 through an inlet side 414 (that is perpendicular to the inlet side 412) as warm, moist air. Accordingly, the first fluid stream 403 passes out of an outlet side 416 as warmer, moister air (as compared to the first fluid stream 403 before passing into the inlet side 412), while the second fluid stream 404 passes out of an outlet side 418 as cooler, drier air (as compared to the second fluid stream 404 before passing into the inlet side 414). In general, the temperature and humidity of the first and second fluid streams 403 and 404 passing through the assembly 400 tends to equilibrate with one another. For example, warm, moist air within the assembly 400 is cooled and dried by heat exchange with cooler, drier air; while cool, dry air is warmed

and moistened by the warmer, cooler air.

[0044] Figure 6 illustrates a perspective top view of an outer casing 502 being positioned on an energy exchange assembly 500, according to an embodiment of the present disclosure. Figure 7 illustrates a perspective top view of the energy exchange assembly 500 having the outer casing 502. The energy exchange assembly 500 may be as described above with respect to Figure 5, for example. Referring to Figures 6 and 7, the casing 502 may include a base 504 connected to upstanding corner beams 506, which, in turn, connect to a cover 508. The base 504 may be secured to lower ends of the beams 506 through fasteners, for example, while the cover 508 may secure to upper ends of the beams 506 through fasteners, for example. The base 504, beams 506, and the cover 508 cooperate to define an internal chamber 510 into which the membrane panels 100 and the spacers 200 may be positioned.

[0045] The outer casing 502 may be formed of a metal (such as aluminum), plastic, or composite material. The outer casing 502 is configured to securely maintain the stack 520 in place to prevent misalignment. Upper and lower filler members 522 may be aligned vertically above and below the stack 520. The upper and lower filler members 522 may be mechanically attached to the cover 508 and the base 504, respectively, to prevent the stack 520 from movement in the vertical plane. The outer casing 502 may be riveted, screwed, bolted, or adhered together, for example. The filler members 506 may be foam layers (for example, polyurethane, Styrofoam, or the like) that compress the stack 520 under constant pressure.

[0046] Figure 8 illustrates a perspective top view of a stacking frame 600, according to an embodiment of the present disclosure. The stacking frame 600 may be used in addition to, or instead of, the outer casing 502 (shown in Figures 6 and 7) to arrange multiple membrane stacks 400 in a stacked arrangement.

[0047] Figure 9 illustrates a perspective top view of an energy exchange assembly 700 having multiple membrane stacks 702 secured within the stacking frame 600, according to an embodiment of the present disclosure. As shown, the individual membrane stacks 702 may be stacked together in various arrangements to increase the size and to modify/customize the dimensions of the energy exchange assembly 700. Thus, instead of a manufacturer having to making several sized assemblies to fit into different HVAC units, modular stacks 702 may be used to form an assembly 700 of desired size. Modular membrane panels and/or membrane stacks 702 reduce part costs and the need for additional sizes of injection-molded parts.

[0048] Referring to Figures 8 and 9, each individual membrane stack 702 may be mounted on the stacking frame 600. The stacking frame 600 may be configured to mount eight or fewer membrane stacks 702 arranged in a cube, as shown in Figure 9. However, the stacking frame 600 may be configured to mount more than eight membrane stacks 702. The stacking frame 600 may include multiple frame members 602 that retain the individual membrane stacks 702 within the assembly 700. The frame members 602 extend vertically from a base 610, and include corner angle members 607, T-angle members 608, and center cross members 609. While not shown, a top cover may be secured to upper ends of the frame members 602 over

the membrane stacks 702.

[0049] The frame members 602 may be configured to keep the membrane stacks 702 separated. For example, the center cross member 609 and T-angle members 608 may separate adjacent vertical columns of membrane stacks 702. The stacking frame 600 may be formed of extruded aluminum, plastic, or like materials. Sealing between each membrane stack 400 and the frame members 602 may be achieved by lining each member 602 with a thin foam layer, which may compress as the stack is assembled to provide a retention force. Alternatively, or in addition, sealant or silicone may be used.

[0050] Figure 10 illustrates a perspective top view of an outer frame 800 of a membrane panel 802, according to an embodiment of the present disclosure. Figure 11 illustrates a corner view of the outer frame 800 of the membrane panel 802. A membrane sheet is not shown in Figures 10 and 11. Referring to Figures 10 and 11, the outer frame 800 may be similar to the outer frame 101, shown in Figures 1 and 2, for example. However, the outer frame 800 may not have a uniform height throughout. Instead, the outer frame 800 may include corners 804 having a height H1 that is greater than a height H2 of the outer frame 800 between the corners 804. The height of the outer frame 800 may smoothly and evenly transition between the height H1 and the height H2. For example, the difference between the heights H1 and H2 may be formed by a sloping or arcuate segment 806 along the top and/or bottom of the outer frame 800. Additionally, the corners 804 may be sloped or curved to increase height in a radial outward direction from a center 830 of an opening 808, such that the greatest height is at each of the four outer corner edges, with the heights sloping downward towards the opening 808.

[0051] Figure 12 illustrates a perspective top view of the membrane panel 802, according to an embodiment of the present disclosure. Figure 13 illustrates a perspective top view of a membrane sheet 850 secured to a corner 804 of the outer frame 800 of the membrane panel 802. Referring to Figures 12 and 13, the membrane sheet 850 may be secured to a top surface of the outer frame 800. Optionally, the membrane sheet 850 may be secured to a bottom surface of the outer frame 800. Also, optionally, a membrane sheet may be secured to the top surface of the outer frame 800, while another membrane sheet may be secured to the bottom surface of the outer frame 800. The sloped corners 804 slope the membrane sheet 850 downwardly between the corners 804. As such, fluid channels 852 may be defined between the corners 804.

[0052] The membrane sheet 850 may be integrated with the outer frame 800. For example, bottom edges of the membrane sheet 850 may be bonded, welded, or the like to the top surface of the outer frame 800. In contrast to the outer frame 101 shown in Figure 1, an entirety of the the outer frame 800 may be on one side of the membrane sheet 850, rather than on two sides. The sloped portions and corners allow for easier bonding, welding, or the like of the membrane sheet 850 to the outer frame 800.

[0053] Figure 14 illustrates a perspective top view of a membrane spacer 900, according to an embodiment of the present disclosure. Figure 15 illustrates a lateral view of a stacking

connecting bracket 902 of the membrane spacer 900. Referring to Figures 14 and 15, the membrane spacer 900 is similar to the membrane spacer 200 (shown in Figure 3), except that that connecting bracket 902 is configured to stack between corners of upper and lower membrane panels 802 (shown in Figure 12 and 13). As such, the contour of the connecting bracket 902 may be a reciprocal shape to the corners 804 (shown in Figures 12 and 13). The connecting bracket 902 includes a beveled end 904 having a thin distal tip 906 that connects to an expanded base 908 through a sloped surface 910. The thin distal tip 906 is configured to be positioned on top of or below the high distal corners 804, while the expanded base 908 is positioned on or below downwardly sloped portions of the corners 804. As such, the membrane spacer 900 is configured to lay flat over the membrane panel 802 shown in Figures 12 and 13.

[0054] As shown, the connecting brackets 902 may include a triangular cross-section (when viewed in cross-section along the profile) on each end to fit against the outer frame 800. Alternatively, the connecting brackets 902 may have other than triangular cross-sectional shapes, depending on the size and shape of the outer frame 800. In at least one embodiment, a thin foam may be added to one side, through either injection-molding or bonding, or an adhesive or sealant may be used to provide sealing between the connecting brackets 902 and the outer frame 800. Additional alignment features (not shown) may be added to both the outer frame 800 and/or the membrane spacer 900 to ensure proper alignment of each layer within a membrane stack.

[0055] Figure 16 illustrates a perspective exploded top view of a membrane stack 1000, according to an embodiment of the present disclosure. Referring to Figures 12-16, the stack 1000 may include alternating layers of the membrane spacers 900 and the membrane panels 802. Each membrane panel 802 may include an outer frame 800 having an integrated membrane sheet 852.

[0056] Figure 17 illustrates a perspective top view of an outer frame 1100 of a membrane panel 1102, according to an embodiment of the present disclosure. Figure 18 illustrates a perspective top view of a corner 1104 of the outer frame 1100 of the membrane panel 1102. The outer frame 1100 is similar to the outer frame 800 shown in Figures 10 and 11, for example. The outer frame 1100 includes two opposed planar brackets 1106 that are parallel with the X axis, and two opposed sloped brackets 1108 that are parallel with the Y axis. The brackets 1106 may be secured to the brackets 1108 through fasteners, bonding, welding, or the like. Optionally, the outer frame 110 may be integrally molded and formed as a single piece, such as through injection-molding. Each sloped bracket 1108 includes a sloped surface 1110 that slopes upwardly from a thin inner edge 1112 to an expanded outer edge 1114 such that the height of the inner edge 1112 is less than the height of the expanded outer edge 1114. The sloped surface 1110 slopes upwardly from an opening 1120 to the distal outer edge 1114. The slope of the sloped surface 1110 may be even and gradual, and may generally be sized and shaped to conform to a reciprocally-shaped connecting bracket of a membrane spacer. The outer frame 1100 may also include an alignment member 1130, such as a post, shoulder, column, block, or the like, downwardly extending from a bottom surface of the corner 1104.

The alignment member 1130 may be used to align the membrane panel 1102 during stacking.

[0057] Figure 19 illustrates a lateral view of a stacking connecting bracket 1200 of a membrane spacer 1202, according to an embodiment of the present disclosure. The membrane spacer 1202 is similar to the membrane spacer 900 shown in Figures 14 and 15, except that that the connecting bracket 1200 is configured to overlay or otherwise connect to the sloped bracket 1108, shown in Figures 17 and 18. The cross-sectional profile of the connecting bracket 1200 may have one side 1204 that is coplanar with a top surface of a beam 1206, and an opposite side 1208 that is sloped in a reciprocal fashion with respect to the slope of the sloped bracket 1108. As shown, the profile of the connecting bracket 1200 may be a right triangle. Optionally, the profile may be formed having various other shapes and sizes, depending on the size and shape of the outer frame to which the connecting bracket 1200 secures.

[0058] Any of the outer frames and the membrane spacers described above may be formed as individual pieces, or integrally formed together as a single piece (such as through injection molding).

[0059] Figure 20 illustrates a simplified schematic view of an energy exchange system 1300 operatively connected to an enclosed structure 1302, according to an embodiment of the present disclosure. The energy exchange system 1300 may include a housing 1304, such as a self-contained module or unit that may be mobile (for example, the housing 1304 may be moved among a plurality of enclosed structures), operatively connected to the enclosed structure 1302, such as through a connection line 1306, such as a duct, tube, pipe, conduit, plenum, or the like. The housing 1304 may be configured to be removably connected to the enclosed structure 1302. Alternatively, the housing 1304 may be permanently secured to the enclosed structure 1302. As an example, the housing 1304 may be mounted to a roof, outer wall, or the like, of the enclosed structure 1302. The enclosed structure 1302 may be a room of a building, a storage structure (such as a grain silo), or the like.

[0060] The housing 1304 includes a supply air inlet 1308 that connects to a supply air flow path 1310. The supply air flow path 1310 may be formed by ducts, conduits, plenum, channels, tubes, or the like, which may be formed by metal and/or plastic walls. The supply air flow path 1310 is configured to deliver supply air 1312 to the enclosed structure 1302 through a supply air outlet 1314 that connects to the connection line 1306.

[0061] The housing 1304 also includes a regeneration air inlet 1316 that connects to a regeneration air flow path 1318. The regeneration air flow path 1318 may be formed by ducts, conduits, plenum, tubes, or the like, which may be formed by metal and/or plastic walls. The regeneration air flow path 1318 is configured to channel regeneration air 1320 received from the atmosphere (for example, outside air) back to the atmosphere through an exhaust air outlet 3122.

[0062] As shown in Figure 20, the supply air inlet 1308 and the regeneration air inlet 1316 may

be longitudinally aligned. For example, the supply air inlet 1308 and the regeneration air inlet 1316 may be at opposite ends of a linear column or row of ductwork. A separating wall 1324 may separate the supply air flow path 1310 from the regeneration air flow path 1318 within the column or row. Similarly, the supply air outlet 1314 and the exhaust air outlet 1322 may be longitudinally aligned. For example, the supply air outlet 1314 and the exhaust air outlet 1322 may be at opposite ends of a linear column or row of ductwork. A separating wall 1326 may separate the supply air flow path 1310 from the regeneration air flow path 1318 within the column or row.

[0063] The supply air inlet 1308 may be positioned above the exhaust air outlet 1322, and the supply air flow path 1310 may be separated from the regeneration air flow path 1318 by a partition 1328. Similarly, the regeneration air inlet 1316 may be positioned above the supply air outlet 1314, and the supply air flow path 1310 may be separated from the regeneration air flow path 1318 by a partition 1330. Thus, the supply air flow path 1310 and the regeneration air flow path 1318 may cross one another proximate to a center of the housing 1304. While the supply air inlet 1308 may be at the top and left of the housing 1304 (as shown in Figure 20), the supply air outlet 1314 may be at the bottom and right of the housing 1304 (as shown in Figure 20). Further, while the regeneration air inlet 1316 may be at the top and right of the housing 1304 (as shown in Figure 20), the exhaust air outlet 1322 may be at the bottom and left of the housing 1304 (as shown in Figure 20).

[0064] Alternatively, the supply air flow path 1310 and the regeneration air flow path 1318 may be inverted and/or otherwise re-positioned. For example, the exhaust air outlet 1322 may be positioned above the supply air inlet 1308. Additionally, alternatively, the supply air flow path 1310 and the regeneration air flow path 1318 may be separated from one another by more than the separating walls 1324 and 1326 and the partitions 1328 and 1330 within the housing 1304. For example, spaces, which may contain insulation, may also be positioned between segments of the supply air flow path 1310 and the regeneration air flow path 1318. Also, alternatively, the supply air flow path 1310 and the regeneration air flow path 3118 may simply be straight, linear segments that do not cross one another. Further, instead of being stacked, the housing 1304 may be shifted 180 degrees about a longitudinal axis aligned with the partitions 1328 and 1330, such that that supply air flow path 1310 and the regeneration air flow path 1318 are side-by-side, instead of one on top of another.

[0065] An air filter 1332 may be disposed within the supply air flow path 1310 proximate to the supply air inlet 1308. The air filter 1332 may be a standard HVAC filter configured to filter contaminants from the supply air 1312. Alternatively, the energy exchange system 1300 may not include the air filter 1332.

[0066] An energy transfer device 1334 may be positioned within the supply air flow path 1310 downstream from the supply air inlet 1308. The energy transfer device 1334 may span between the supply air flow path 1310 and the regeneration air flow path 1318. For example, a supply portion or side 1335 of the energy transfer device 1334 may be within the supply air flow path 1310, while a regenerating portion or side 1337 of the energy transfer device 1334

may be within the regeneration air flow path 1318. The energy transfer device 1334 may be a desiccant wheel, for example. However, the energy transfer device 1334 may be various other systems and assemblies, such as including liquid-to-air membrane energy exchangers (LAMEEs), as described below.

[0067] An energy exchange assembly 1336, such as described above with respect to Figures 1-19, is disposed within the supply air flow path 1310 downstream from the energy transfer device 1334. The energy exchange assembly 1336 may be positioned at the junction of the separating walls 1324, 1326 and the partitions 1328, 1330. The energy exchange assembly 1336 may be positioned within both the supply air flow path 1310 and the regeneration air flow path 1318. As such, the energy exchange assembly 1336 is configured to transfer energy between the supply air 1312 and the regeneration air 1320.

[0068] One or more fans 1338 may be positioned within the supply air flow path 1310 downstream from the energy exchange assembly 1336. The fan(s) 1338 is configured to move the supply air 1312 from the supply air inlet 1308 and out through the supply air outlet 1314 (and ultimately into the enclosed structure 1302). Alternatively, the fan(s) 1338 may be located at various other areas of the supply air flow path 1310, such as proximate to the supply air inlet 1308. Also, alternatively, the energy exchange system 1300 may not include the fan(s).

[0069] The energy exchange system 1300 may also include a bypass duct 1340 having an inlet end 1342 upstream from the energy transfer device 1334 within the supply air flow path 1310. The inlet end 1342 connects to an outlet end 1344 that is downstream from the energy transfer device 1334 within the supply air flow path 1310. An inlet damper 1346 may be positioned at the inlet end 1342, while an outlet damper 1348 may be positioned at the outlet end 1344. The dampers 1346 and 1348 may be actuated between open and closed positions to provide a bypass line for the supply air 1312 to bypass around the energy transfer device 1334. Further, a damper 1350 may be disposed within the supply air flow path 1310 downstream from the inlet end 1342 and upstream from the energy transfer device 1334. The damper 1350 may be closed in order to allow the supply air 1312 to flow into the bypass duct 1340 around the energy transfer device 1334. The dampers 1346, 1348, and 1350 may be modulated between fully-open and fully-closed positions to allow a portion of the supply air 1312 to pass through the energy transfer device 1334 and a remaining portion of the supply air 1312 to bypass the energy transfer device 1334. As such, the bypass dampers 1346, 1348, and 1350 may be operated to control the temperature and humidity of the supply air 1312 as it is delivered to the enclosed structure 1302. Examples of bypass ducts and dampers are further described in United States Patent Application No. 13/426,793, which was filed March 22, 2012, and is hereby incorporated by reference in its entirety. Alternatively, the energy exchange system 1300 may not include the bypass duct 1340 and dampers 1346, 1348, and 1350.

[0070] As shown in Figure 20, the supply air 1312 enters the supply air flow path 1310 through the supply air inlet 1308. The supply air 1312 is then channeled through the energy transfer device 1334, which pre-conditions the supply air 1312. After passing through the energy transfer device 1334, the supply air 1312 is pre-conditioned and passes through the energy

exchange assembly 1336, which conditions the pre-conditioned supply air 1312. The fan(s) 1338 may then move the supply air 1312, which has been conditioned by the energy exchange assembly 1336, through the energy exchange assembly 1336 and into the enclosed structure 1302 through the supply air outlet 1314.

[0071] With respect to the regeneration air flow path 1318, an air filter 1352 may be disposed within the regeneration air flow path 1318 proximate to the regeneration air inlet 1316. The air filter 1352 may be a standard HVAC filter configured to filter contaminants from the regeneration air 1320. Alternatively, the energy exchange system 1300 may not include the air filter 1352.

[0072] The energy exchange assembly 1336 may be disposed within the regeneration air flow path 1318 downstream from the air filter 1352. The energy exchange assembly 1336 may be positioned within both the supply air flow path 1310 and the regeneration air flow path 1318. As such, the energy exchange assembly 1336 is configured to transfer sensible energy and latent energy between the regeneration air 1320 and the supply air 1312.

[0073] A heater 1354 may be disposed within the regeneration air flow path 1318 downstream from the energy exchange assembly 1336. The heater 1354 may be a natural gas, propane, or electric heater that is configured to heat the regeneration air 1320 before it encounters the energy transfer device 1334. Optionally, the energy exchange system 1300 may not include the heater 1354.

[0074] The energy transfer device 1334 is positioned within the regeneration air flow path 1318 downstream from the heater 1354. As noted, the energy transfer device 1334 may span between the regeneration air flow path 1318 and the supply air flow path 1310.

[0075] As shown in Figure 20, the supply side 1335 of the energy transfer device 1334 is disposed within the supply air flow path 1310 proximate to the supply air inlet 1308, while the regeneration side 1337 of the energy transfer device 1334 is disposed within the regeneration air flow path 1310 proximate to the exhaust air outlet 1322. Accordingly, the supply air 1312 encounters the supply side 1335 as the supply air 1312 enters the supply air flow path 1310 from the outside, while the regeneration air 1320 encounters the regeneration side 1337 just before the regeneration air 1320 is exhausted out of the regeneration air flow path 1318 through the exhaust air outlet 1322.

[0076] One or more fans 1356 may be positioned within the regeneration air flow path 1318 downstream from the energy transfer device 1334. The fan(s) 1356 is configured to move the regeneration air 1320 from the regeneration air inlet 1316 and out through the exhaust air outlet 1322 (and ultimately into the atmosphere). Alternatively, the fan(s) 1356 may be located at various other areas of the regeneration air flow path 1318, such as proximate to the regeneration air inlet 1316. Also, alternatively, the energy exchange system 1300 may not include the fan(s).

[0077] The energy exchange system 1300 may also include a bypass duct 1358 having an inlet end 1360 upstream from the energy transfer device 1334 within the regeneration air flow path 1318. The inlet end 1360 connects to an outlet end 1362 that is downstream from the energy transfer device 1334 within the regeneration air flow path 1318. An inlet damper 1364 may be positioned at the inlet end 1360, while an outlet damper 1366 may be positioned at the outlet end 1362. The dampers 1364 and 1366 may be actuated between open and closed positions to provide a bypass line for the regeneration air 1320 to flow around the energy transfer device 1334. Further, a damper 1368 may be disposed within the regeneration air flow path 1318 downstream from the heater 1354 and upstream from the energy transfer device 334. The damper 1368 may be closed in order to allow the regeneration air to bypass into the bypass duct 1358 around the energy transfer device 1334. The dampers 1364, 1366, and 1368 may be modulated between fully-open and fully-closed positions to allow a portion of the regeneration air 1320 to pass through the energy transfer device 1334 and a remaining portion of the regeneration air 1320 to bypass the energy transfer device 1334. Alternatively, the energy exchange system 1300 may not include the bypass duct 1358 and dampers 1364 and 1366.

[0078] As shown in Figure 20, the regeneration air 1320 enters the regeneration air flow path 1318 through the regeneration air inlet 1316. The regeneration air 1320 is then channeled through the energy exchange assembly 1336. After passing through the energy exchange assembly 1336, the regeneration air 1320 passes through the heater 1354, where it is heated, before encountering the energy transfer device 1334. The fan(s) 1356 may then move the regeneration air 1320 through the energy transfer device 1334 and into the atmosphere through the exhaust air outlet 1322.

[0079] As described above, the energy exchange assembly 1336 may be used with respect to the energy exchange system 300. Optionally, the energy exchange assembly 1336 may be used with various other systems that are configured to condition outside air and supply the conditioned air as supply air to an enclosed structure, for example. The energy exchange assembly 1336 may be positioned within a supply air flow path, such as the path 1310, and a regeneration or exhaust air flow path, such as the path 1318, of a housing, such as the housing 1304. The energy exchange system 1300 may include only the energy exchange assembly 1336 within the paths 1310 and 1318 of the housing 1304, or may alternatively include any of the additional components shown and described with respect to Figure 20.

[0080] Referring to Figures 1-20, embodiments of the present disclosure provide membrane panels that include an outer frame that is integrated or integrally formed with a membrane sheet. The membrane sheet may be inserted into a mold and material, such as plastic, that forms the outer frame may be injection-molded onto or around portions of the membrane sheet. In other embodiments, the membrane sheet may be ultrasonically welded to the outer frame. In other embodiments, the membrane sheet may be secured to the outer frame, such as through portions being melted through lasers, for example.

[0081] Figure 21 illustrates a simplified cross-sectional view of a mold 1400 configured to form

a membrane panel 1402, according to an embodiment of the present disclosure. The mold 1400 includes an internal chamber 1404 that is configured to receive liquid plastic, for example. A membrane sheet 1406 may be suspended within portions of the mold 1400 so that outer edges 1408 extend into the internal chamber 1404. Hot, liquid plastic 1410 is injected into the internal chamber 1404 through one or more inlets 1412. The liquid plastic 1410 flows around the outer edges 1408. As the liquid plastic 1410 cools and hardens to form the outer frame, the plastic securely fixes to the outer edges 1408. In this manner, the membrane sheet 1406 may be integrally formed with the outer frame. The formed membrane panel 1402 may then be removed from the mold 1400.

[0082] Figure 22 illustrates a simplified representation of a membrane sheet 1500 being integrated with an outer frame 1502 of a membrane panel 1504, according to an embodiment of the present disclosure. The outer frame 1502 may include an upstanding ridge 1506. The ridge 1506 may provide an energy director that is used to create a robust bond between the outer frame 1502 and the membrane sheet 1500. The ridge 1506 may be a small profile on the outer frame 1502 that is configured to direct and focus emitted energy thereto. An energy-emitting device 1508, such as an ultrasonic welder, laser, or the like, emits focused energy, such as ultrasonic energy, a laser beam, or the like, into the membrane sheet 1500 over the ridge 1506. The emitted energy securely bonds the outer frame 1502 to the ridge 1506, such as by melting portions of the membrane sheet 1500 to the ridge 1506, or vice versa. In this manner, the membrane sheet 1500 may be integrally formed with the outer frame 1502. Alternatively, the outer frame 1502 may not include the ridge 1506.

[0083] Figure 23 illustrates a lateral view of a connecting bracket 1600 of a membrane spacer 1602, according to an embodiment of the present disclosure. A channel 1604 may be formed in the connecting bracket 1600. The channel 1604 may retain a gasket 1606, which may be used to provide a sealing interface between the connecting bracket 1600 and a membrane panel. The channel 1604 and the gasket 1606 may be used with respect to any of the membrane spacers described above, such as those shown in Figures 3, 14, 15, 17, 18, and 19, for example.

[0084] Figure 24 illustrates a flow chart of a method of forming a membrane panel, according to an embodiment of the present disclosure. The method may begin at 1700, in which an outer frame of the membrane panel is formed. For example, separate and distinct brackets may be securely connected together to form the outer frame. Optionally, the outer frame may be integrally molded and formed through injection-molding.

[0085] At 1702, a portion of a membrane sheet may be connected to at least a portion of the outer frame. 1700 and 1702 may simultaneously occur. For example, a membrane sheet may be inserted into a mold, such that edge portions of the membrane sheet are positioned within an internal chamber of the mold. Injection-molded plastic may flow within the internal chamber around the edge portions. Optionally, a membrane sheet may be positioned on top of or below an outer frame.

[0086] Next, at 1704, energy is exerted into an interface between the membrane sheet and the outer frame. For example, energy in the form of the heat of the injection-molded plastic may be exerted into the edge portions of the membrane sheet. As the plastic cools and hardens, thereby forming the outer frame, the edge portions of the membrane sheet securely fix to the hardening plastic. Alternatively, energy in the form of ultrasonic, laser, heat, or other such energy may be focused into an interface between the outer frame and the membrane sheet to melt the edge portions to the outer frame, or vice versa. Then, at 1706, the membrane sheet is integrated into the outer frame through the exerted energy.

[0087] While various spatial and directional terms, such as top, bottom, lower, mid, lateral, horizontal, vertical, front and the like may be used to describe embodiments of the present disclosure, it is understood that such terms are merely used with respect to the orientations shown in the drawings. The orientations may be inverted, rotated, or otherwise changed, such that an upper portion is a lower portion, and vice versa, horizontal becomes vertical, and the like.

[0088] It is to be understood that the above description is intended to be illustrative, and not restrictive. For example, the above-described embodiments (and/or aspects thereof) may be used in combination with each other. In addition, many modifications may be made to adapt a particular situation or material to the teachings of the various embodiments of the disclosure without departing from their scope. While the dimensions and types of materials described herein are intended to define the parameters of the various embodiments of the disclosure, the embodiments are by no means limiting and are exemplary embodiments. Many other embodiments will be apparent to those of skill in the art upon reviewing the above description. The scope of the various embodiments of the disclosure should, therefore, be determined with reference to the appended claims, along with the full scope of equivalents to which such claims are entitled. In the appended claims, the terms "including" and "in which" are used as the plain-English equivalents of the respective terms "comprising" and "wherein." Moreover, the terms "first," "second," and "third," etc. are used merely as labels, and are not intended to impose numerical requirements on their objects. Further, the limitations of the following claims are not written in means-plus-function format and are not intended to be interpreted based on 35 U.S.C. § 112(f), unless and until such claim limitations expressly use the phrase "means for" followed by a statement of function void of further structure.

[0089] This written description uses examples to disclose the various embodiments of the disclosure, including the best mode, and also to enable any person skilled in the art to practice the various embodiments of the disclosure, including making and using any devices or systems and performing any incorporated methods. The patentable scope of the various embodiments of the disclosure is defined by the claims, and may include other examples that occur to those skilled in the art. Such other examples are intended to be within the scope of the claims if the examples have structural elements that do not differ from the literal language of the claims, or if the examples include equivalent structural elements with insubstantial differences from the literal languages of the claims.

REFERENCES CITED IN THE DESCRIPTION

This list of references cited by the applicant is for the reader's convenience only. It does not form part of the European patent document. Even though great care has been taken in compiling the references, errors or omissions cannot be excluded and the EPO disclaims all liability in this regard.

Patent documents cited in the description

- [CH193732A \[0006\]](#)
- [GB1354502A \[0006\]](#)
- [US20090294110A \[0006\]](#)
- [US13797062B \[0036\]](#)
- [US13426793B \[0069\]](#)

Patentkrav

1. Membranpanelanordning (100) konfigureret til at fastgøres inde i en energiudvekslingsanordning (400, 500, 700), hvilken membranpanelanordning omfatter:

5 to membranpaneler (802), som hver omfatter:

en yderramme (101) som definere en midteråbning; og

10 en membranplade (102) integreret med yderrammen (101), hvor membranpladen (102) spænder over midteråbningen, og hvor membranpladen er konfigureret til at overføre sensibel energi og latent energi derigennem; og hvor membranpanelanordningen yderligere omfatter:

15 et membranafstandsstykke (900) adskilt fra og anbragt mellem de to membranpaneler (802), idet membranafstandsstykket (900) omfatter et forbindelsesbeslag (902) konfigureret til at anbringes mellem hjørner af yderrammer (101) af de to membranpaneler (802), idet forbindelsesbeslaget (902) omfatter en affaset ende (904) med en distal spids (906), som er forbundet med en bund (908) via en skrånende overflade (910).

20 **2.** Membranpanelanordningen ifølge krav 1, hvor yderrammen (101) er sprøjttestøbt omkring kantafsnit af membranpladen (102).

3. Membranpanelanordningen ifølge et hvilket som helst af kravene 1 til 2, hvor membranpladen (102) er ultrasonisk bundet til yderrammen (101).

25

4. Membranpanelanordningen ifølge et hvilket som helst af kravene 1 til 2, hvor membranpladen (102) er laserbundet til yderrammen (101).

5. Membranpanelanordningen ifølge et hvilket som helst af kravene 1 til 2, hvor
30 membranpladen (102) er varmeforseglet til yderrammen (101).

- 6.** Membranpanelanordningen ifølge et hvilket som helst af kravene 1 til 5, hvor yderrammen (101) inkluderer en flerhed af beslag (104, 106) med inderkanter, som definerer midteråbningen.
- 5 **7.** Membranpanelanordningen ifølge krav 6, hvor en eller flere afstandsstykkefastgørende funktioner (120) er dannet gennem eller i mindst en af inderkanterne.
- 8.** Membranpanelanordningen ifølge et hvilket som helst af kravene 1 til 7, hvor
10 yderrammen (101) inkluderer en flerhed af opretstående hjørner (804).
- 9.** Membranpanelanordningen ifølge et hvilket som helst af kravene 1 til 8, hvor membranpladen (102) er integreret med yderrammen (101) uden et klæbemiddel.
15
- 10.** Membranpanelanordning ifølge et hvilket som helst af kravene 1 til 9, hvor yderrammen (101) passer sammen med mindst et separat membranafstandsstykke (200) for at danne mindst en luftstrømskanal.
- 20 **11.** Membranpanelanordning ifølge et hvilket som helst af kravene 1 til 10, hvor yderrammen (101) er sammenstøbt og -formet med membranafstandsstykket.
- 12.** Energiudvekslingsanordning omfattende: en flerhed af membranpanelanordninger, hvor hver af flerheden af membranpanelanordning er
25 ifølge et hvilket som helst af kravene 1 til 11,
- 13.** Energiudvekslingsanordningen ifølge krav 12, hvor flerheden af membranpaneler inkluderer en første gruppe af membranpaneler og en anden gruppe af membranpaneler, hvor den første gruppe membranpaneler er retvinklet
30 orienteret i forhold til den anden gruppe af membranpaneler.

14. Energiudvekslingsanordningen ifølge et hvilket som helst af kravene 12 til 13, hvor yderrammen (101) inkluderer mindst et skrånende forbindelsesbeslag konfigureret til at passe til en gensidig funktion af en af flerheden af afstandsstykker (200, 900).

5

15. Fremgangsmåde til at danne en membranpanelanordning (100) konfigureret til at fastgøres inde i en energiudvekslingsanordning (400), hvilken fremgangsmåde omfatter:

at danne to membranpaneler (802), hvor det at danne hver membranpanel

10 omfatter:

at danne en yderramme (101), som definerer en midteråbning; og

at integrere en membranplade (102) med yderrammen, hvor den porøse membranplade spænder over midteråbningen, og hvor membranpladen er konfigureret til at overføre sensibel energi og latent energi derigennem; og

15 hvor fremgangsmåden yderligere omfatter:

at danne et membranafstandsstykke (900) adskilt fra og anbragt mellem de to membranplader (802), idet membranafstandsstykket (900) omfatter et forbindelsesbeslag (902) konfigureret til at anbringes mellem hjørner af yderrammerne (101) af de to membranpaneler (802), idet

20 forbindelsesbeslaget (902) omfatter en affaset ende (904) med en distal spids (906), som er forbundet med en bund (908) via en skrånende overflade (910).

25

DRAWINGS

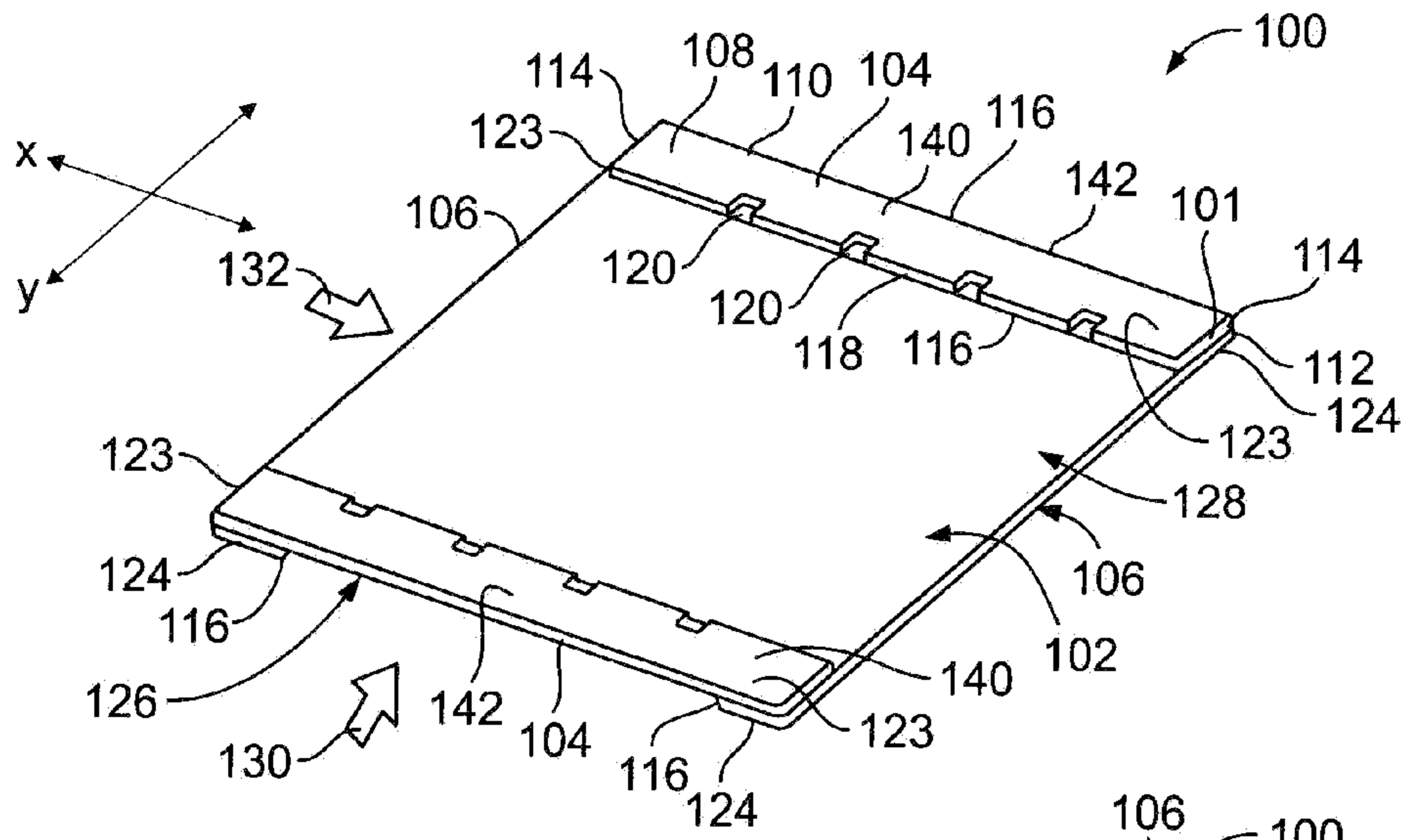

FIG. 1

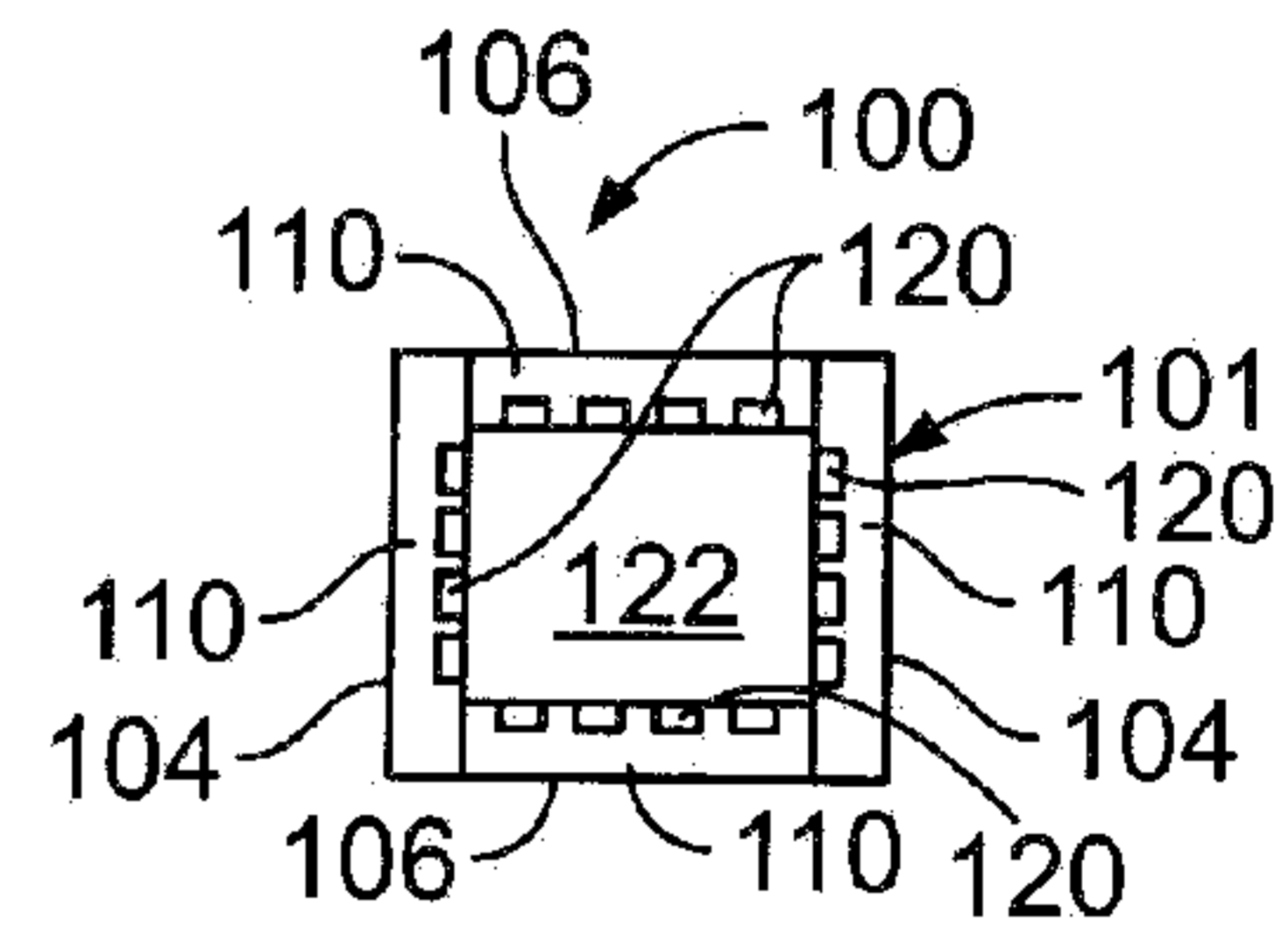

FIG. 2

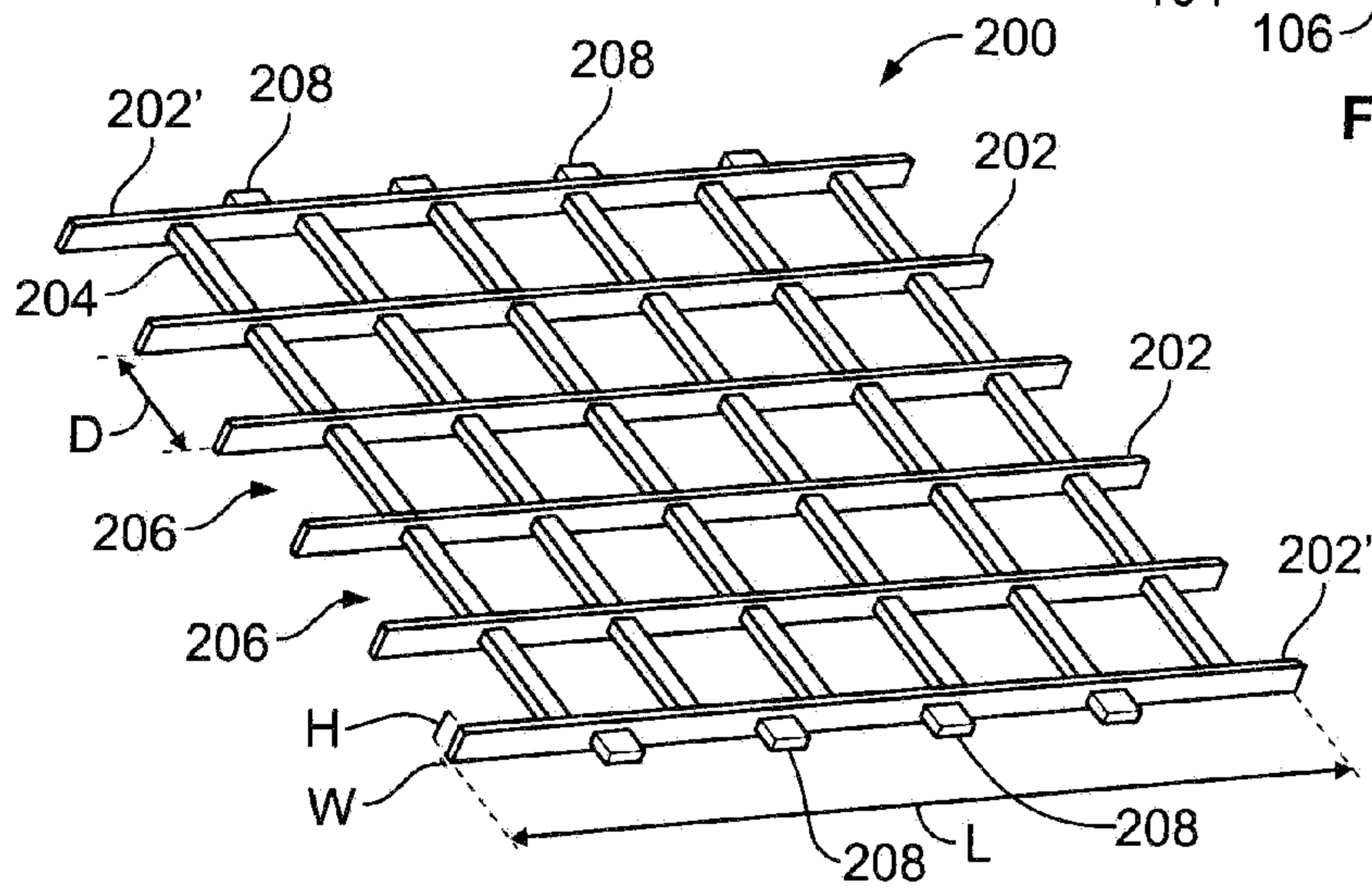

FIG. 3

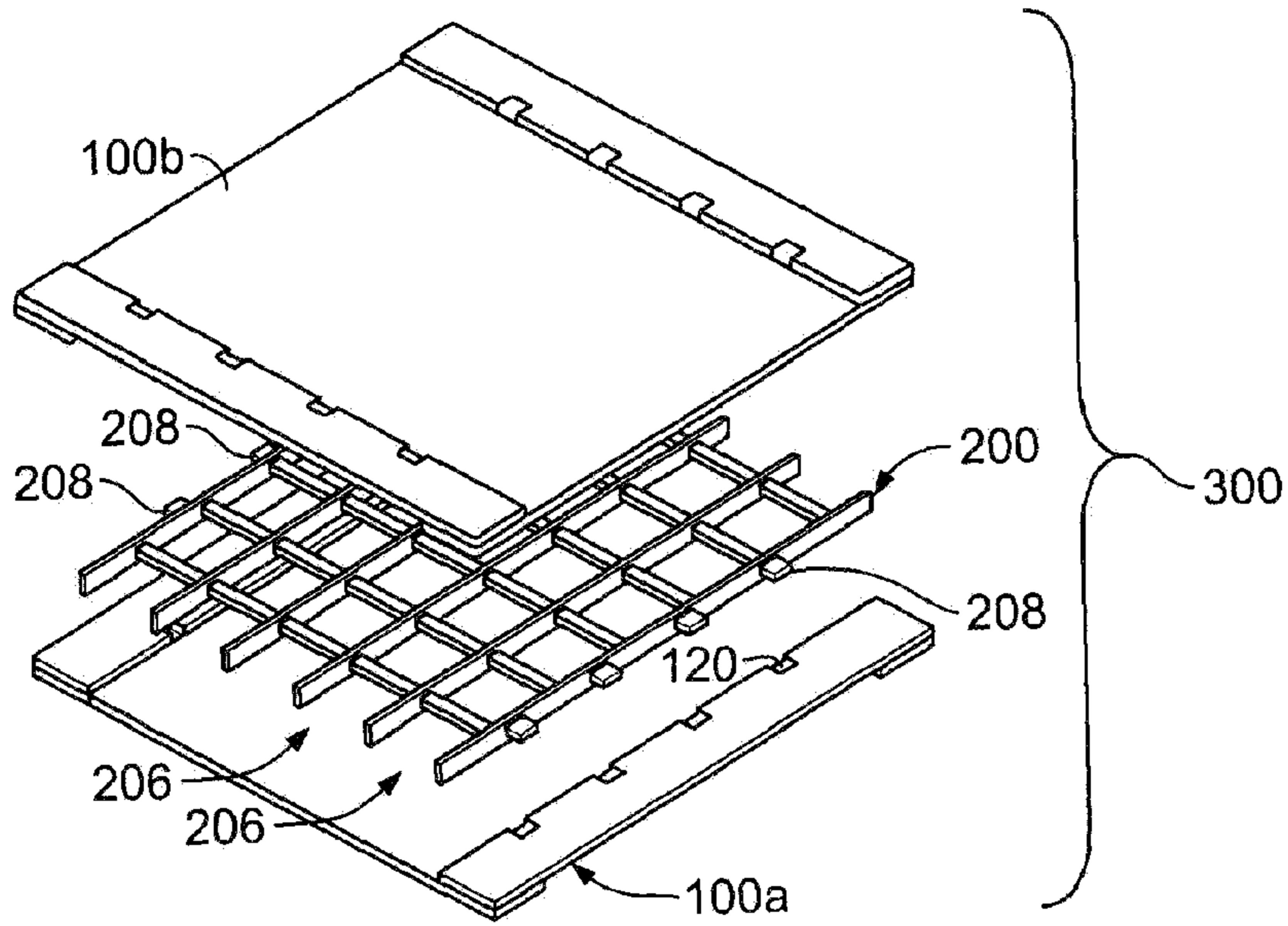

FIG. 4

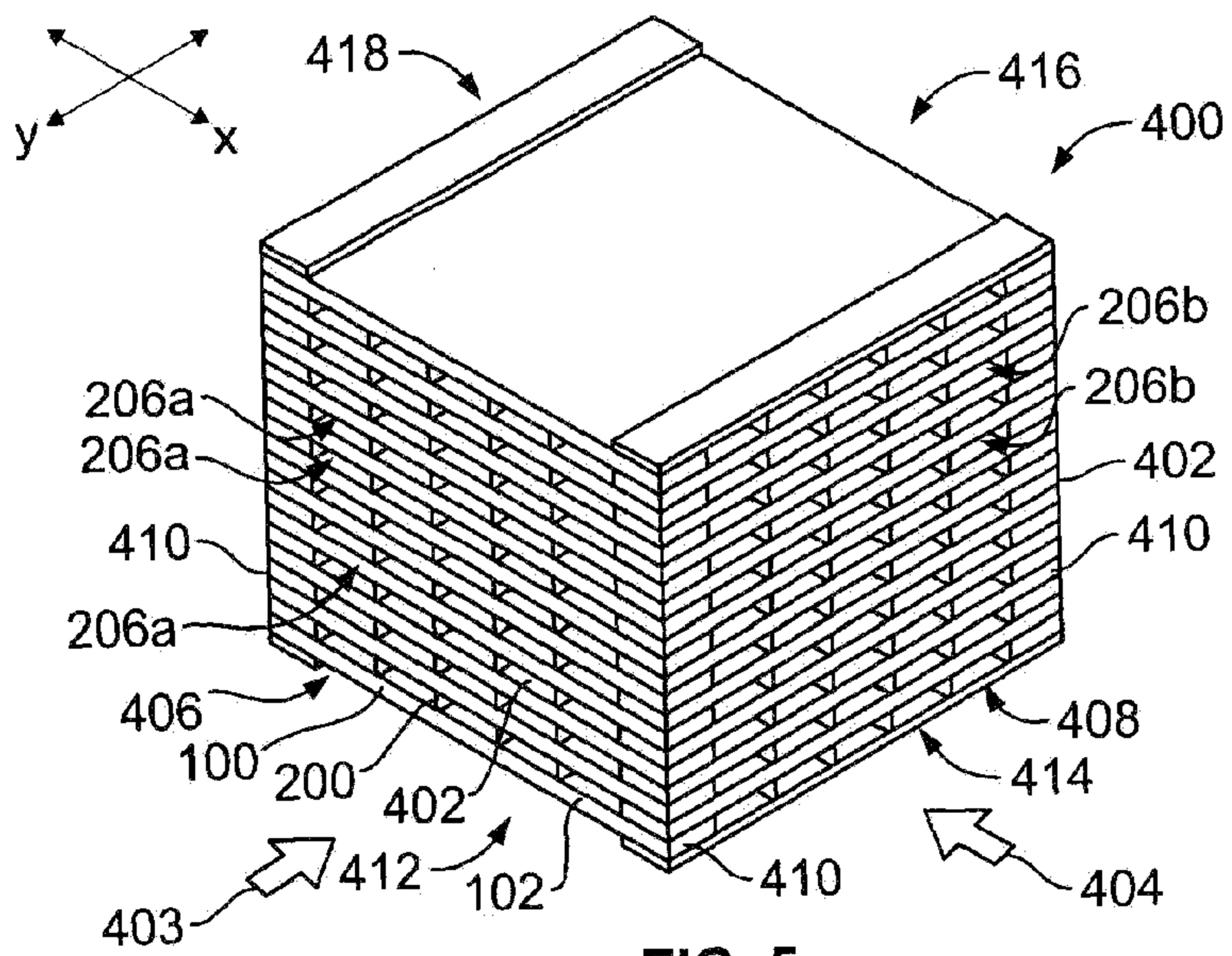

FIG. 5

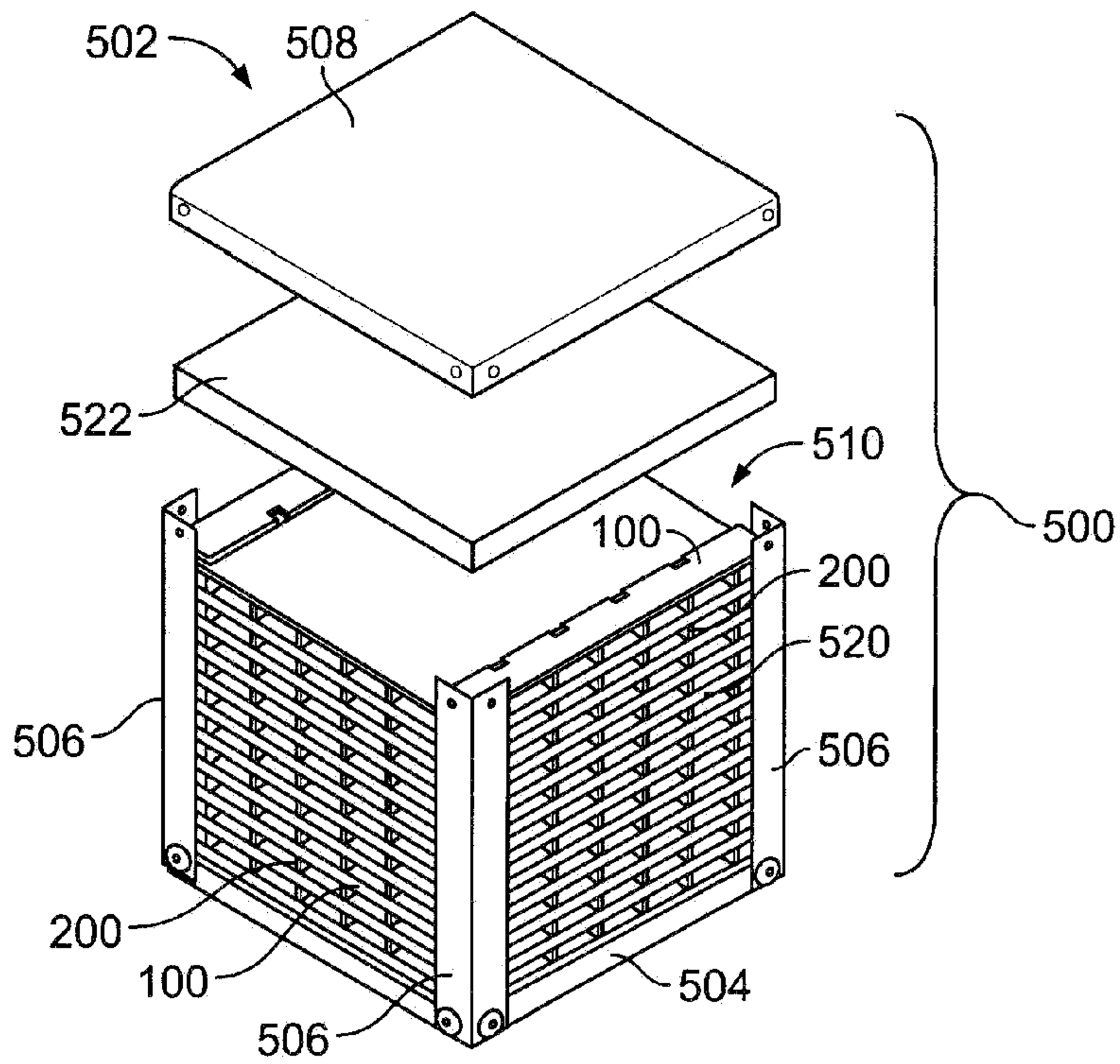

FIG. 6

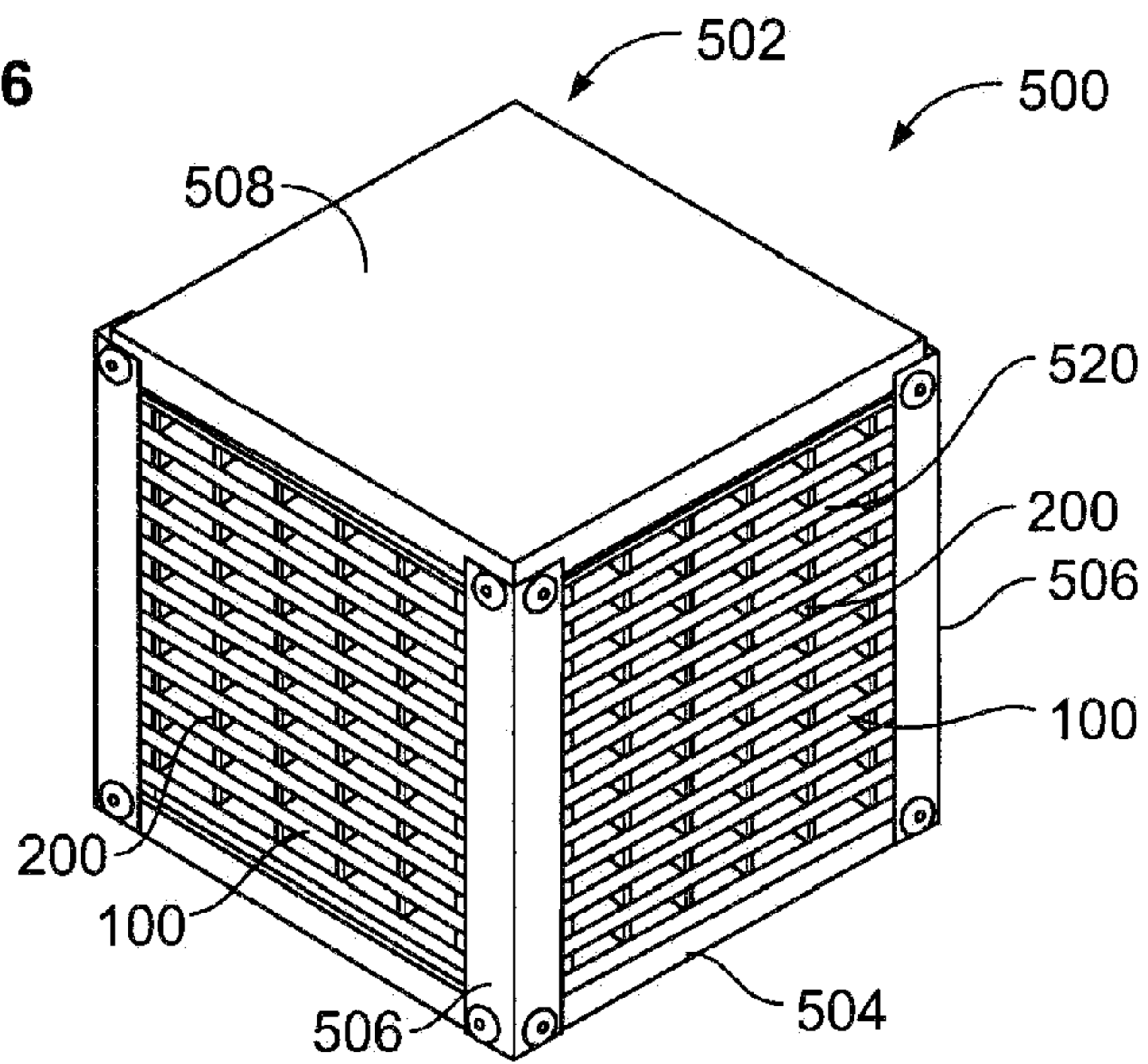

FIG. 7

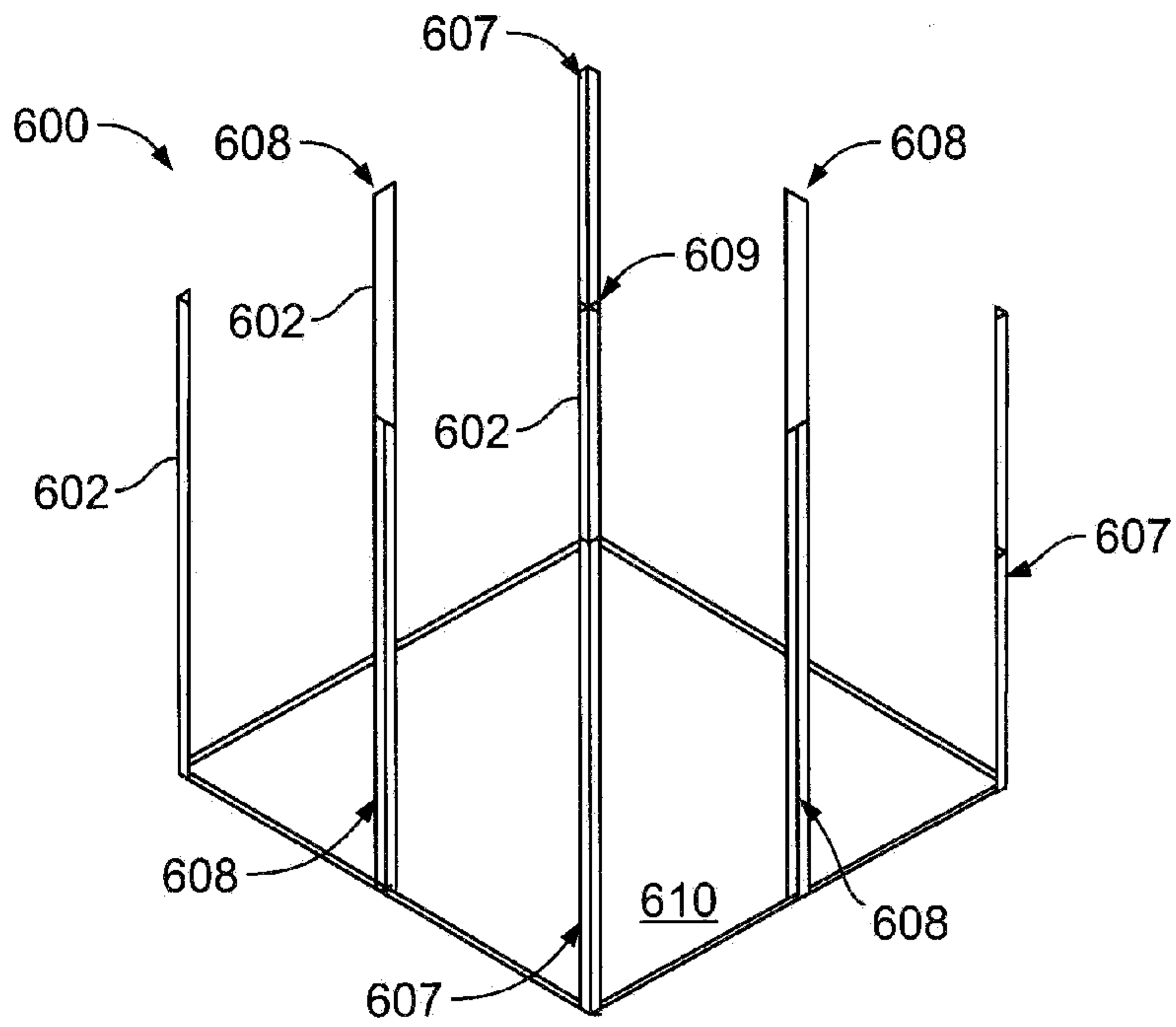

FIG. 8

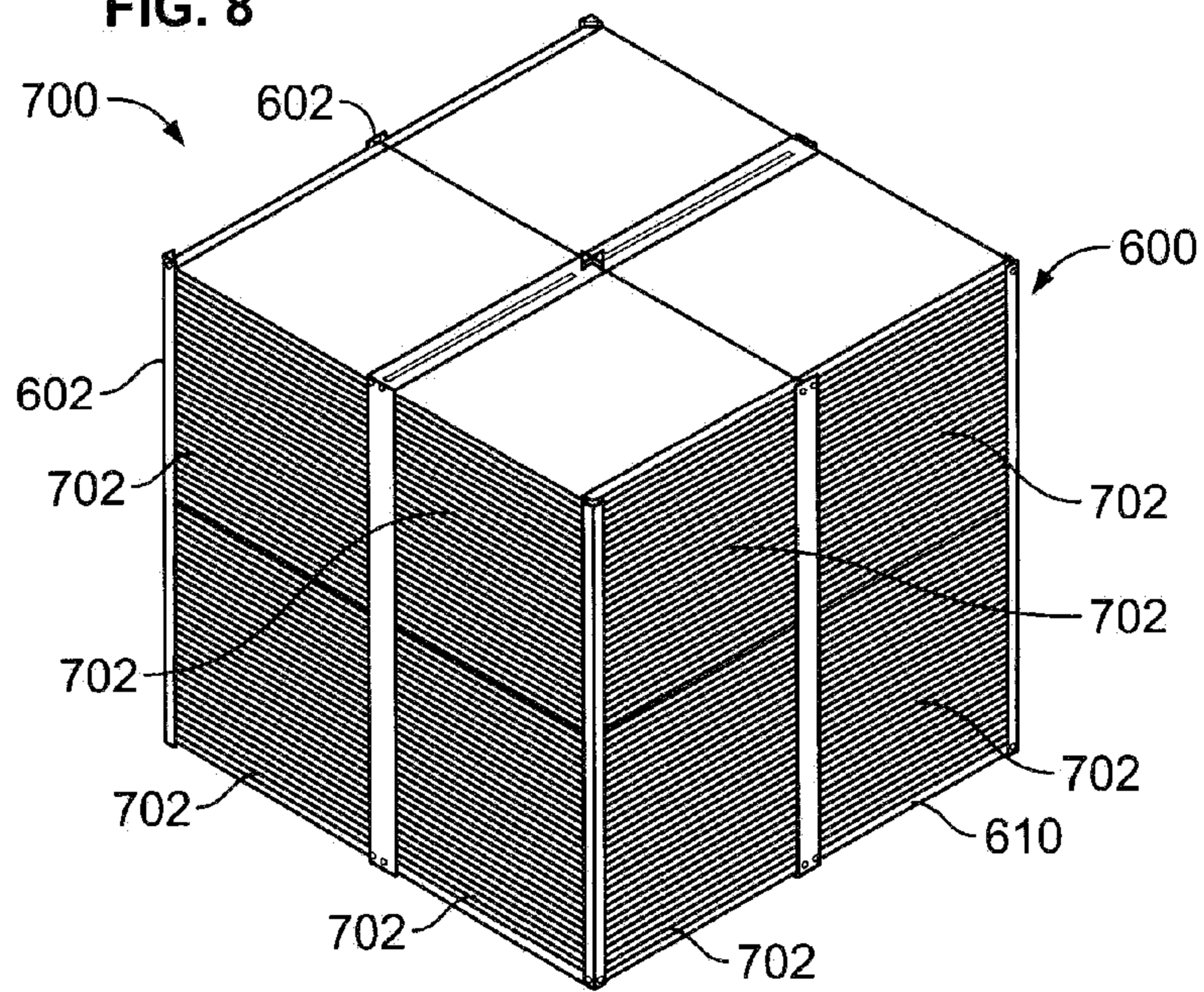

FIG. 9

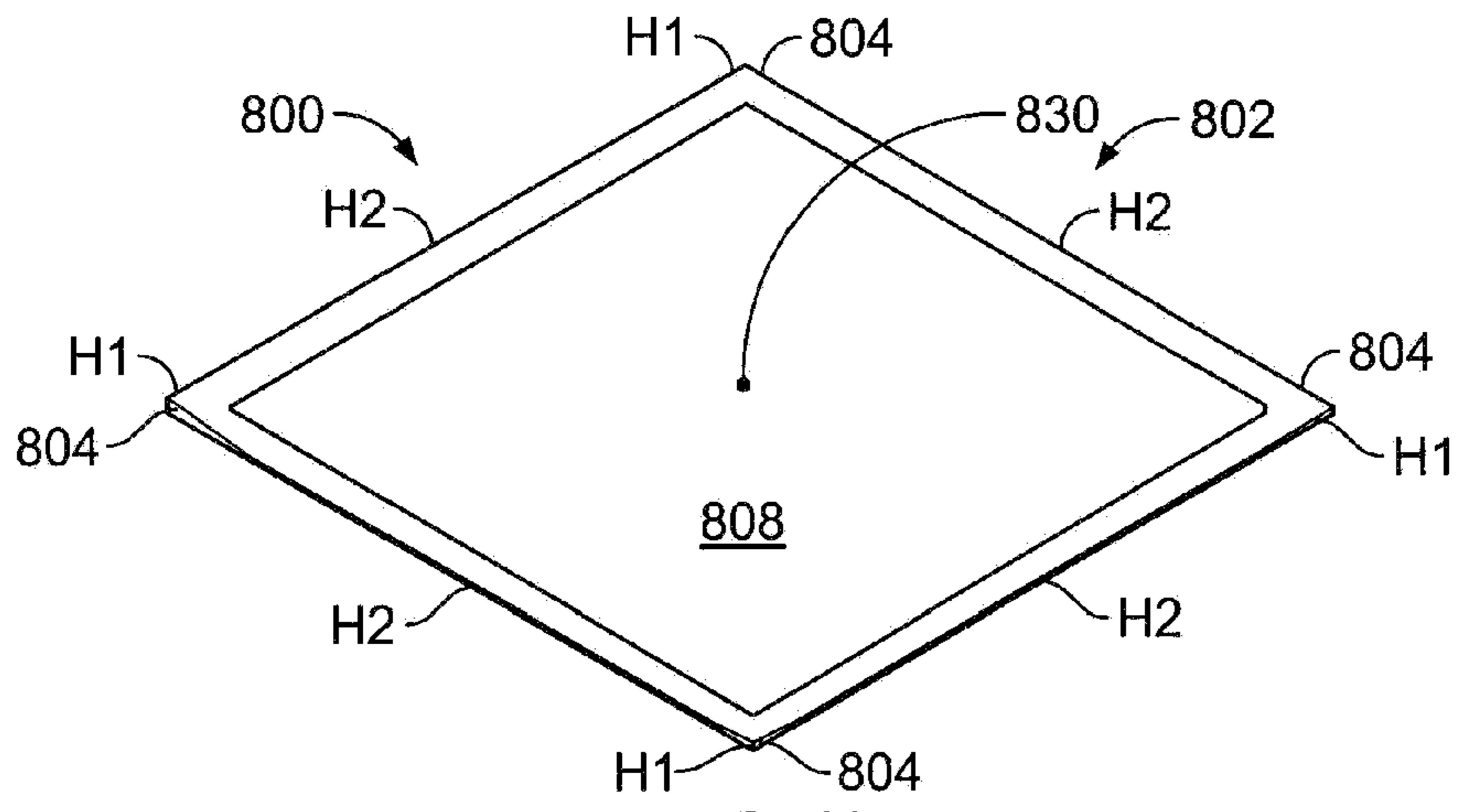

FIG. 10

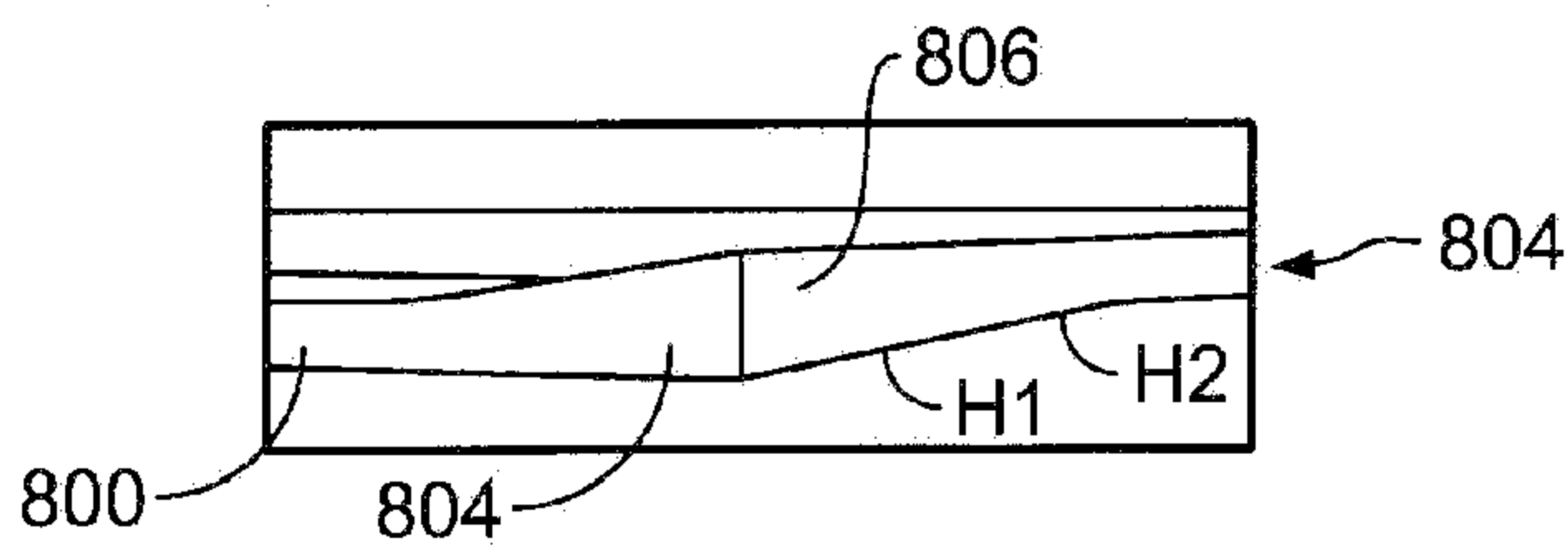

FIG. 11

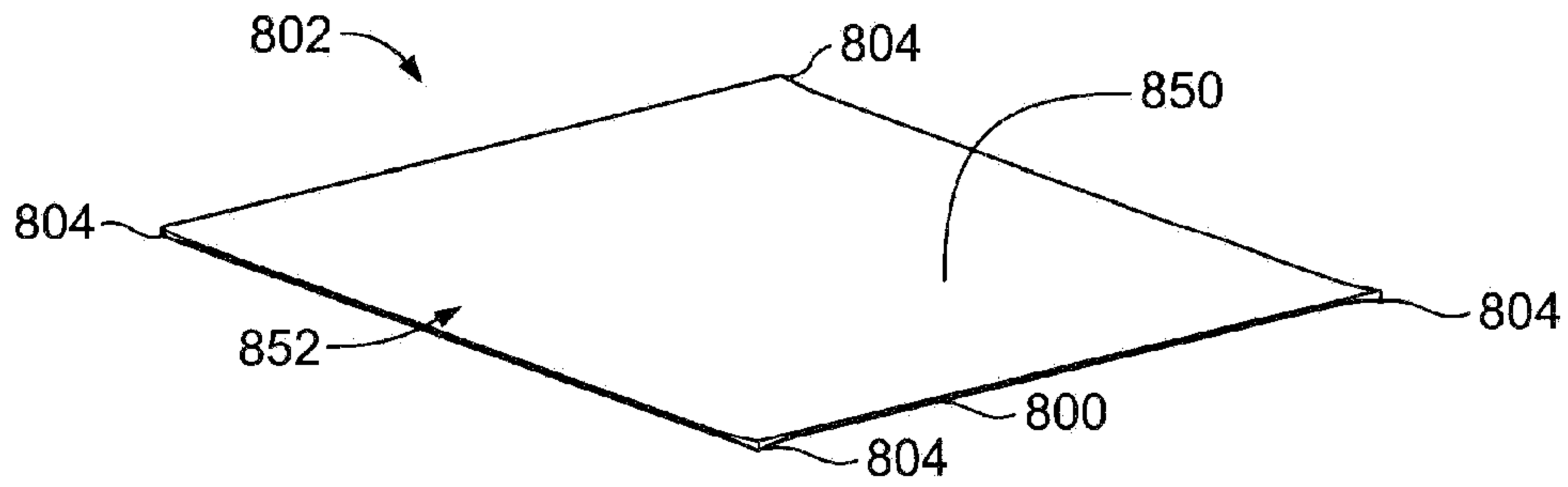

FIG. 12

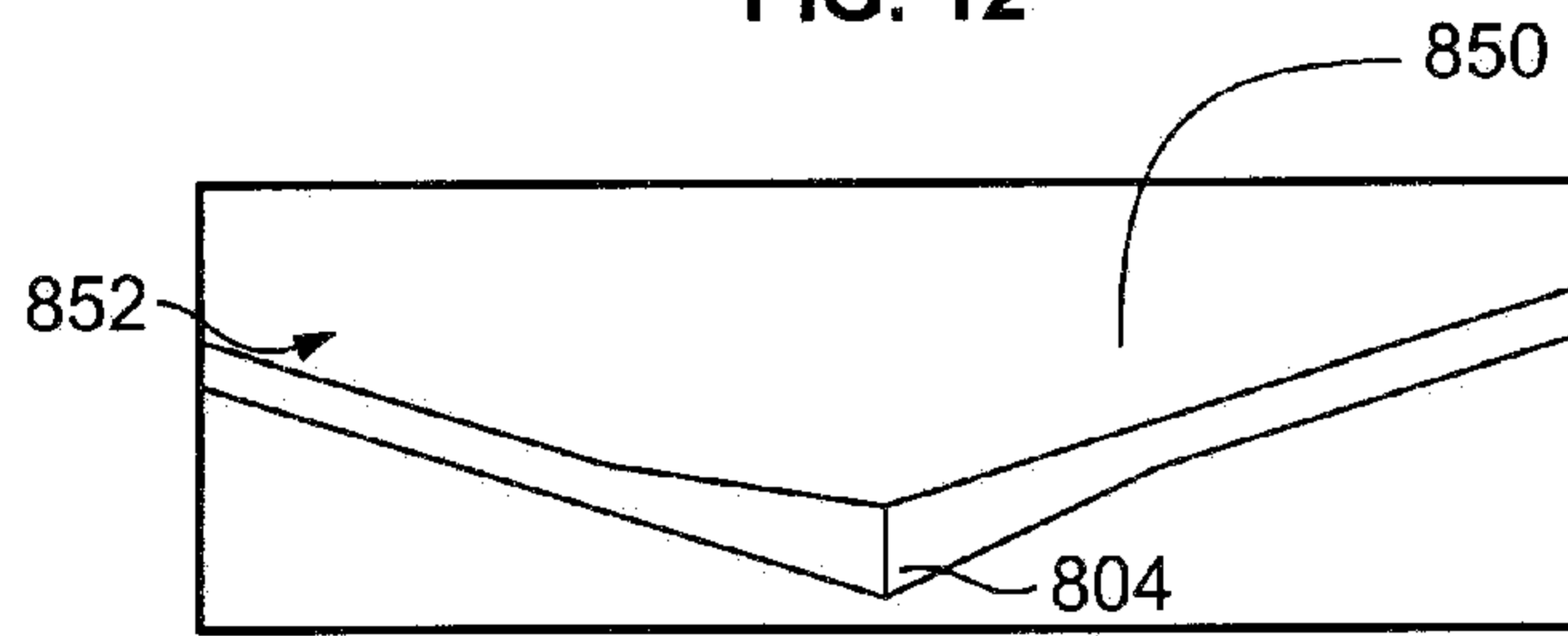

FIG. 13

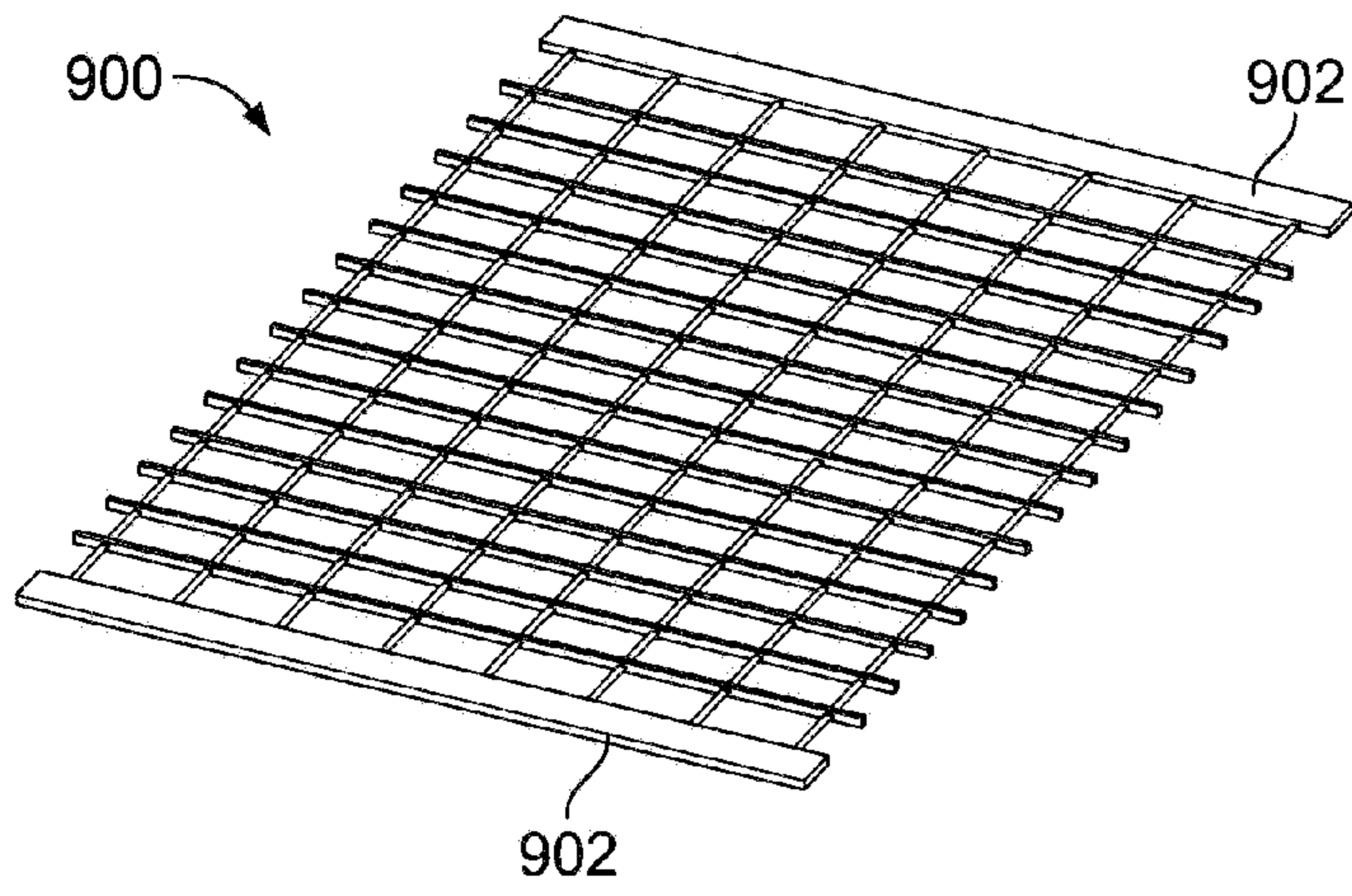

FIG. 14

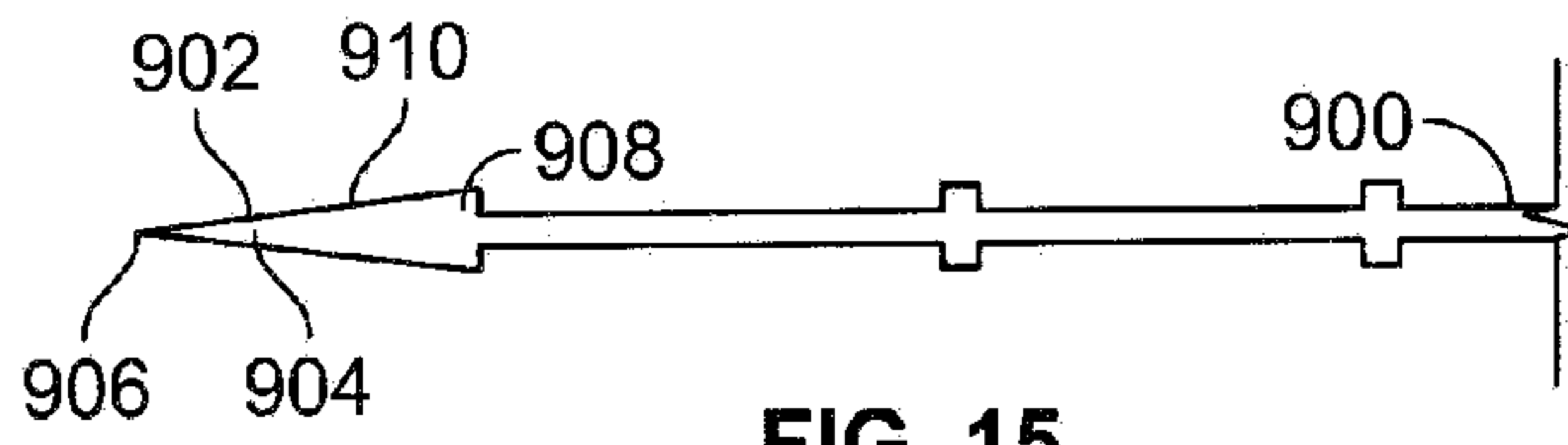

FIG. 15

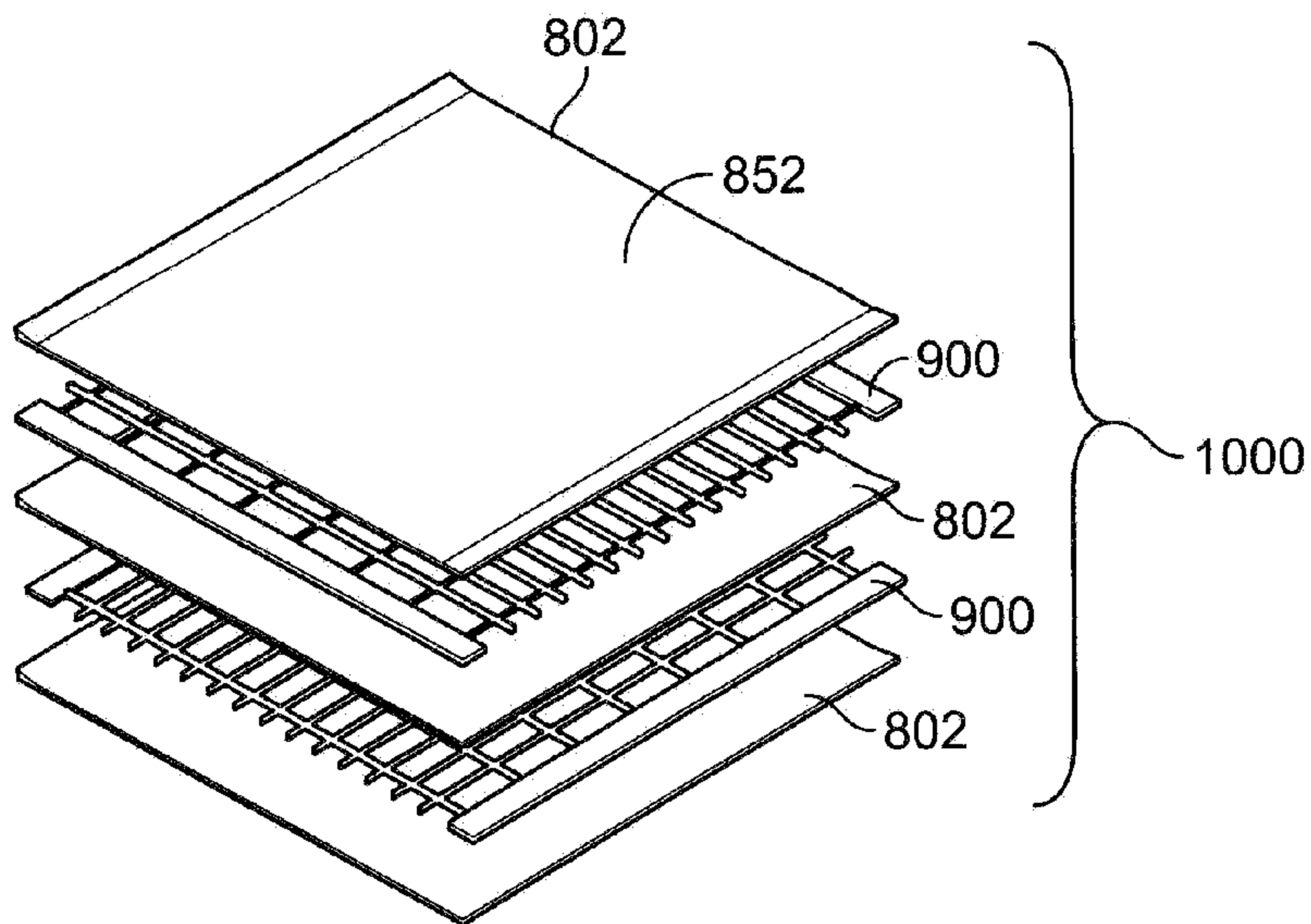

FIG. 16

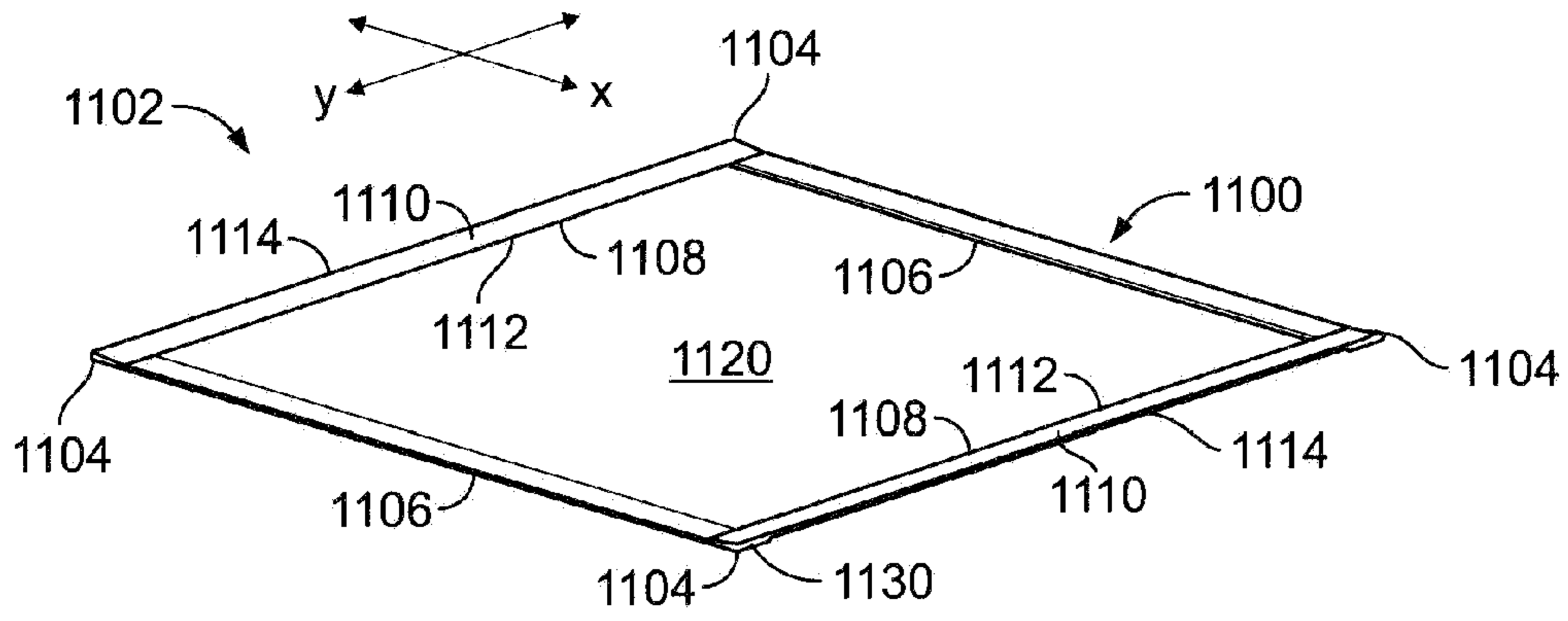

FIG. 17

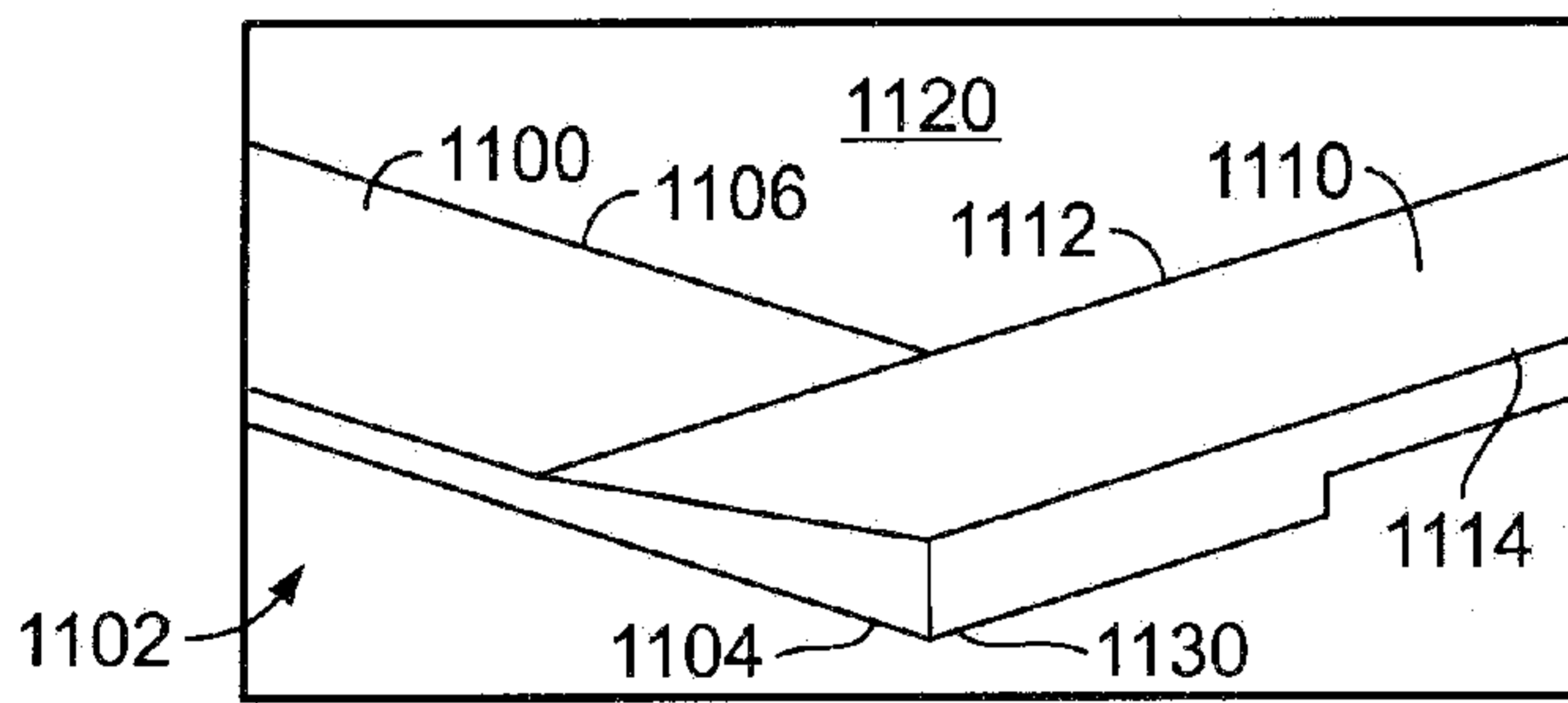

FIG. 18

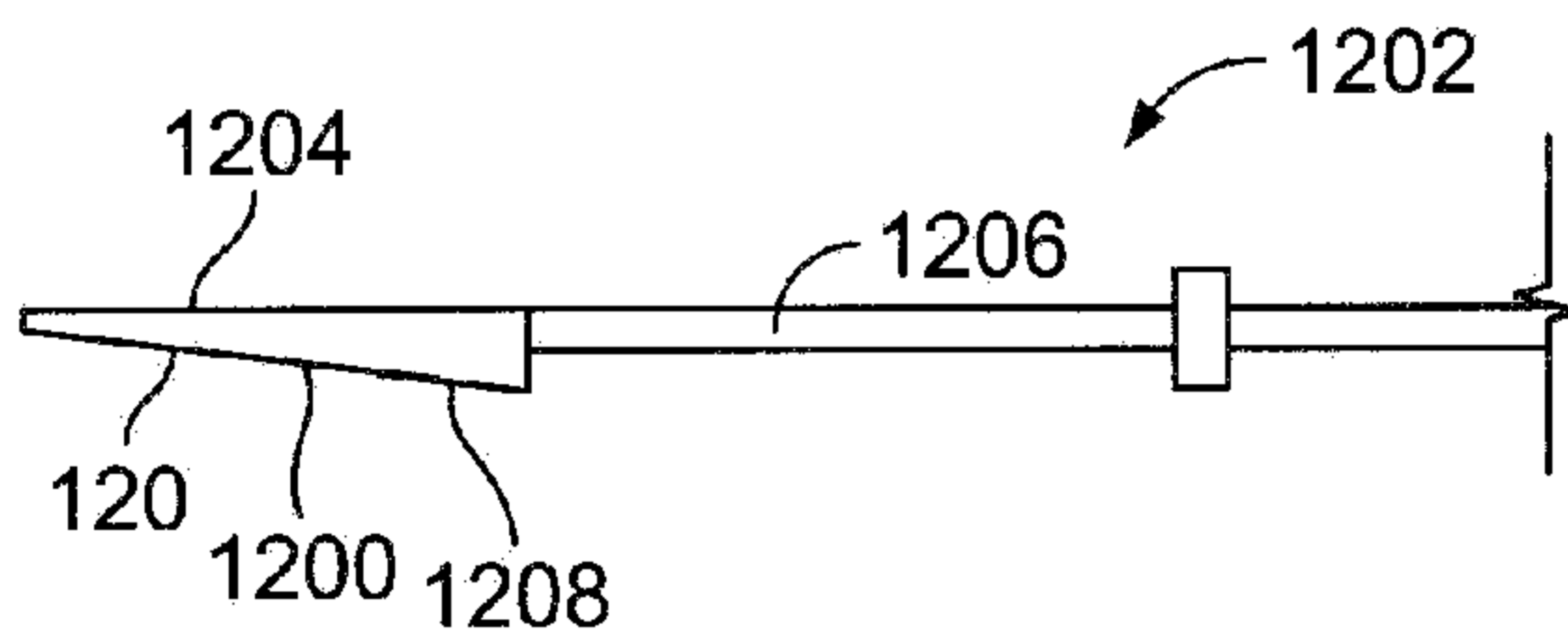

FIG. 19

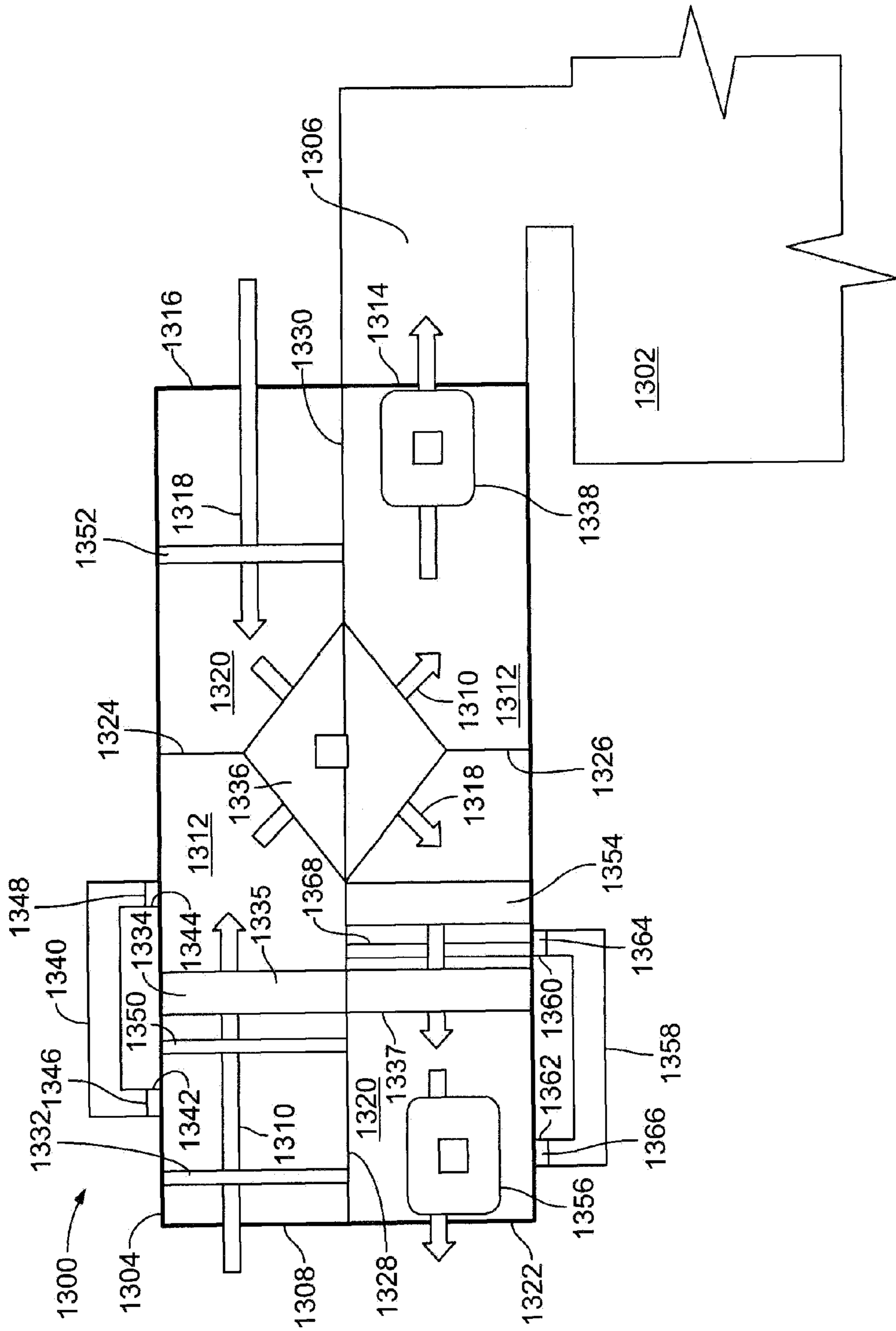

FIG. 20

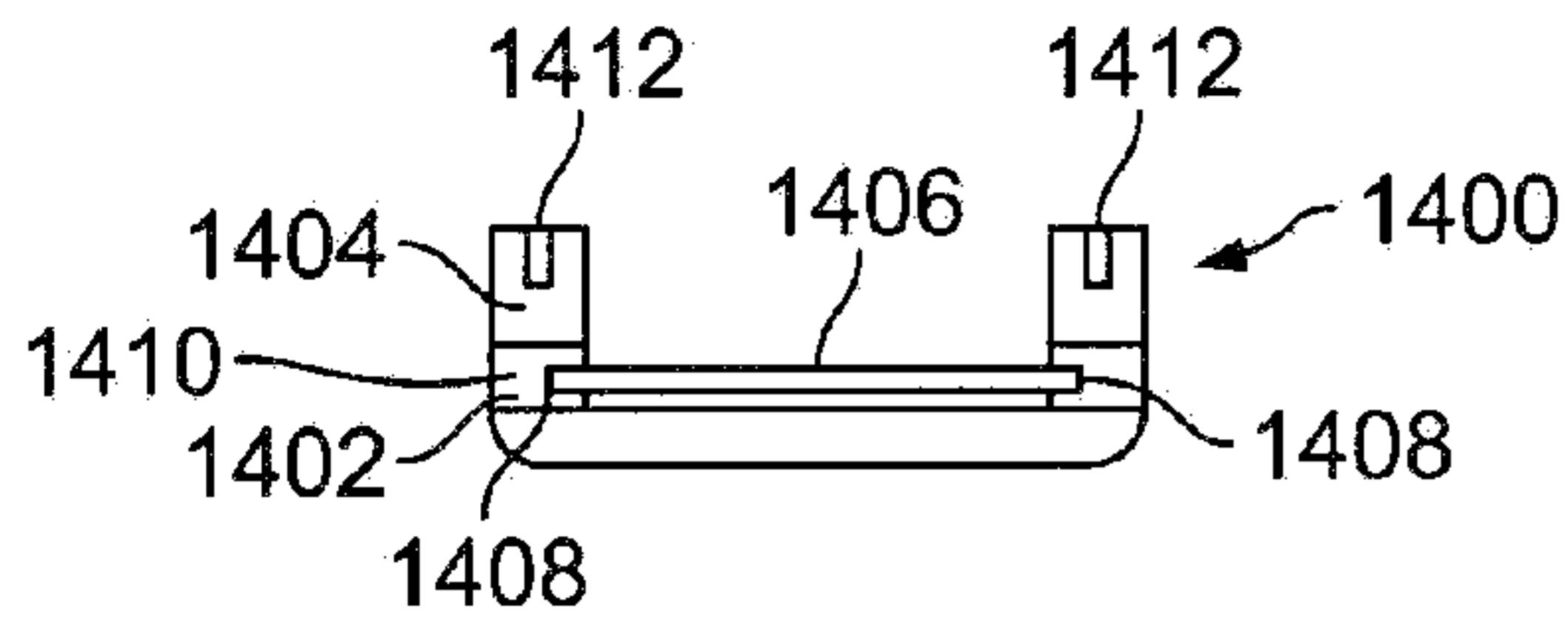

FIG. 21

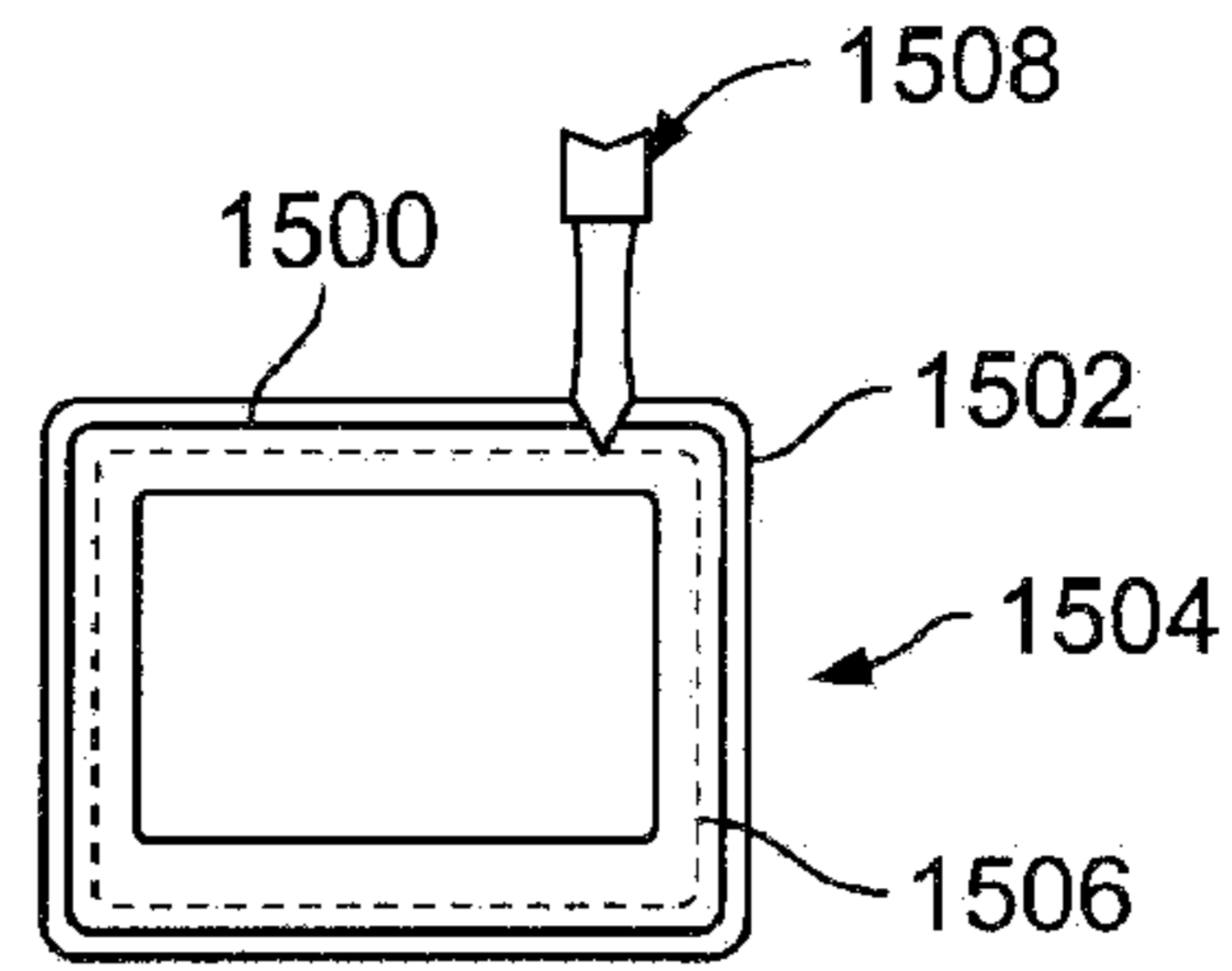

FIG. 22

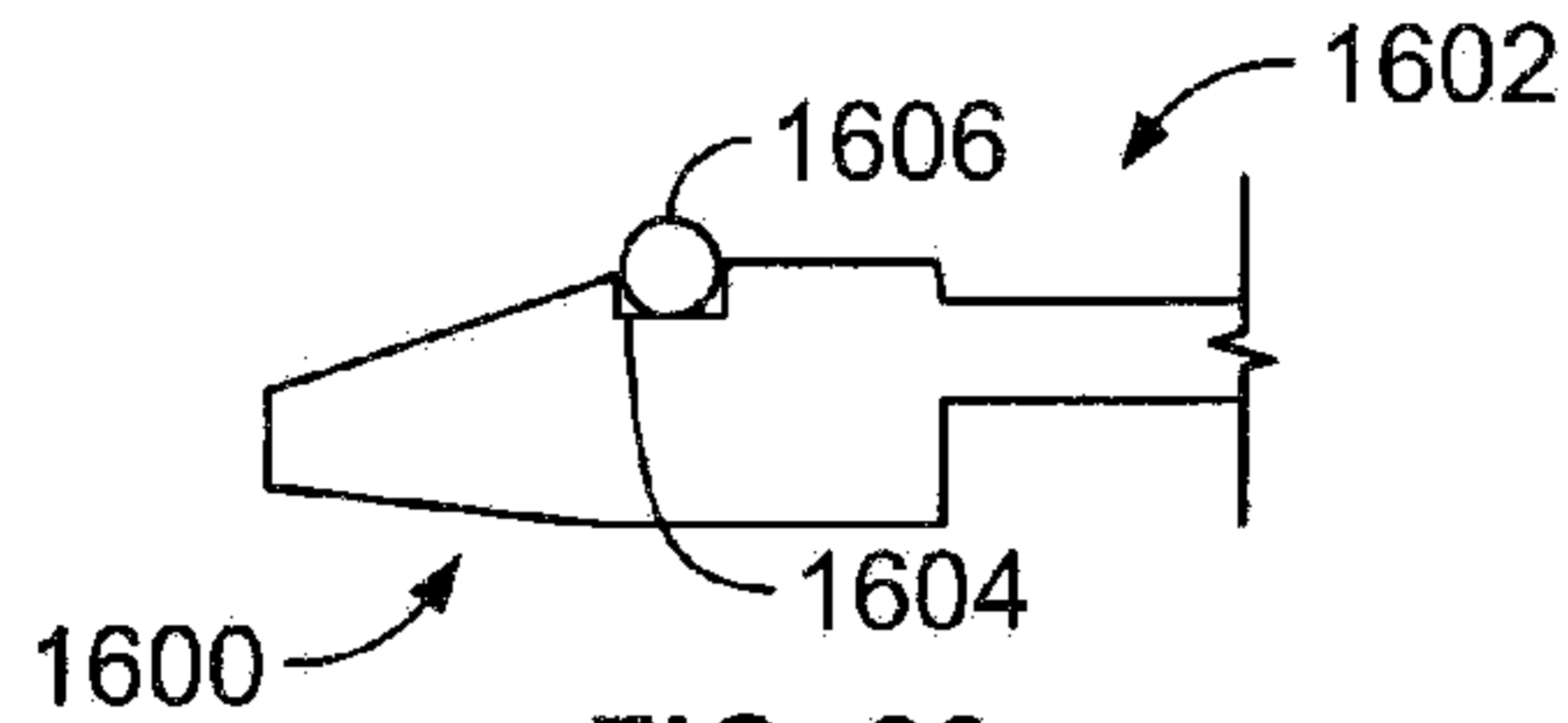

FIG. 23

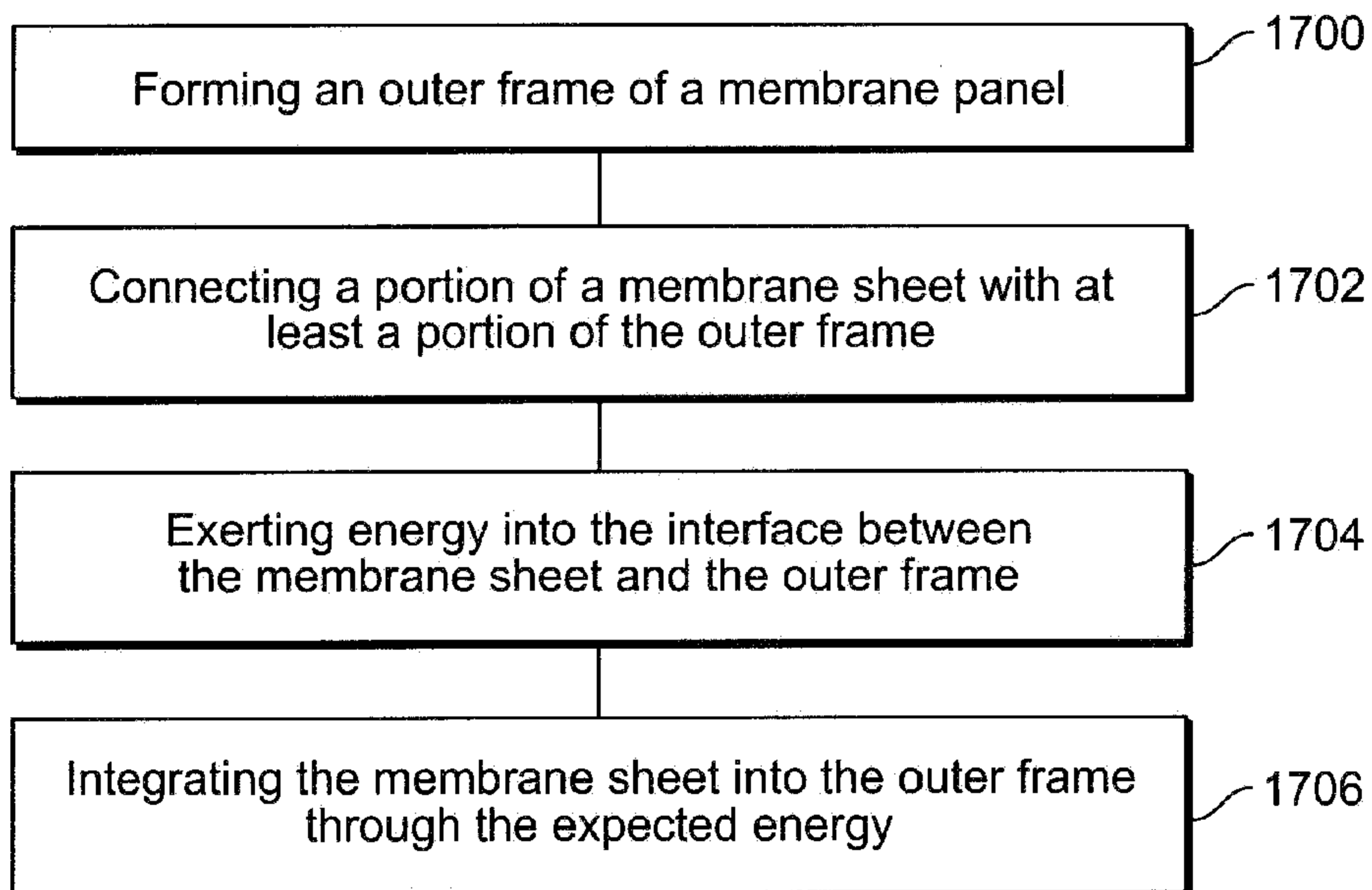

FIG. 24