



(51) International Patent Classification:

A61N 1/05 (2006.01) G01K 1/14 (2006.01)
A61M 25/02 (2006.01) H01R 13/58 (2006.01)

(21) International Application Number:

PCT/US2013/023643

(22) International Filing Date:

29 January 2013 (29.01.2013)

(25) Filing Language:

English

(26) Publication Language:

English

(30) Priority Data:

61/635,784 19 April 2012 (19.04.2012) US

(71) Applicant: **MEDTRONIC, INC.** [US/US]; 710 Medtronic Parkway NE, Minneapolis, Minnesota 55432 (US).

(72) Inventors: **BONDHUS, Spencer M.**; 1923 40th Avenue NE, Columbia Heights, Minnesota 55421 (US). **STEM, Bryan D.**; 706 Pierce St. NE, #1, Minneapolis, Minnesota 55413 (US).

(74) Agents: **FRANZEN, Rick L.** et al.; Medtronic, Inc., 710 Medtronic Parkway NE, Minneapolis, MN 55432 (US).

(81) Designated States (unless otherwise indicated, for every kind of national protection available): AE, AG, AL, AM, AO, AT, AU, AZ, BA, BB, BG, BH, BN, BR, BW, BY,

BZ, CA, CH, CL, CN, CO, CR, CU, CZ, DE, DK, DM, DO, DZ, EC, EE, EG, ES, FI, GB, GD, GE, GH, GM, GT, HN, HR, HU, ID, IL, IN, IS, JP, KE, KG, KM, KN, KP, KR, KZ, LA, LC, LK, LR, LS, LT, LU, LY, MA, MD, ME, MG, MK, MN, MW, MX, MY, MZ, NA, NG, NI, NO, NZ, OM, PA, PE, PG, PH, PL, PT, QA, RO, RS, RU, RW, SC, SD, SE, SG, SK, SL, SM, ST, SV, SY, TH, TJ, TM, TN, TR, TT, TZ, UA, UG, US, UZ, VC, VN, ZA, ZM, ZW.

(84) Designated States (unless otherwise indicated, for every kind of regional protection available): ARIPO (BW, GH, GM, KE, LR, LS, MW, MZ, NA, RW, SD, SL, SZ, TZ, UG, ZM, ZW), Eurasian (AM, AZ, BY, KG, KZ, RU, TJ, TM), European (AL, AT, BE, BG, CH, CY, CZ, DE, DK, EE, ES, FI, FR, GB, GR, HR, HU, IE, IS, IT, LT, LU, LV, MC, MK, MT, NL, NO, PL, PT, RO, RS, SE, SI, SK, SM, TR), OAPI (BF, BJ, CF, CG, CI, CM, GA, GN, GQ, GW, ML, MR, NE, SN, TD, TG).

Declarations under Rule 4.17:

- as to applicant's entitlement to apply for and be granted a patent (Rule 4.17(ii))
- as to the applicant's entitlement to claim the priority of the earlier application (Rule 4.17(iii))

[Continued on next page]

(54) Title: STRAIN RELIEF LOOP HOLDERS FOR MEDICAL LEADS AND SYSTEMS

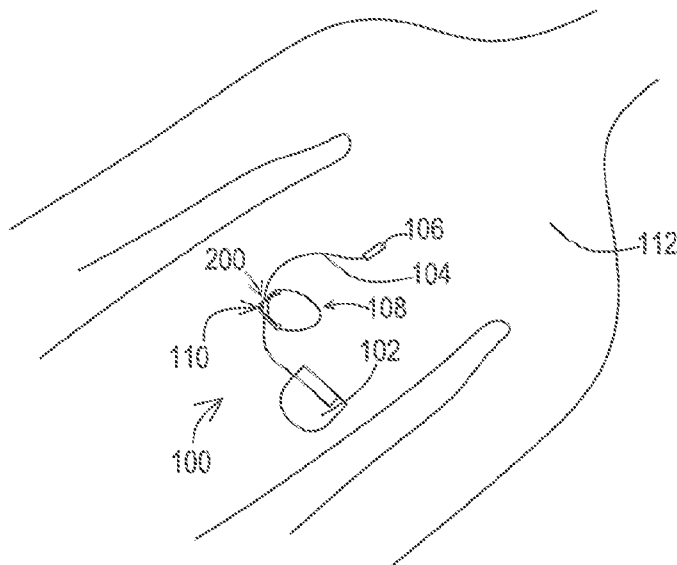

FIG. 1

(57) Abstract: Strain relief loop holders maintaining strain relief loop formed in a lead while also addressing excessive heating at the point in the loop where the medical lead intersects itself. The strain relief loop includes a body section that the medical lead passes through where the intersection occurs. The body section may be a thermal non-conductor and isolate from excessive heating at the intersection point or may be a thermal conductor and distribute the excessive heating. The strain relief loop may include features such as arms or a coil extending from the body segment with arm segments at the ends of the arms defining lead passageways that assist in maintaining the strain relief loop. The body segment may have a single lead passageway where the intersection point occurs or may have multiple lead passageways. The body itself may house the loop by forming a loop or a capsule.



Published:

— *with international search report (Art. 21(3))*

STRAIN RELIEF LOOP HOLDERS FOR MEDICAL LEADS AND SYSTEMS

TECHNICAL FIELD

Embodiments are related to strain relief loops for medical leads. More particularly, embodiments are related to strain relief loop holders that establish a strain relief loop for medical leads.

BACKGROUND

Medical leads provide electrical stimulation from a medical device to a target site within a body of a patient. The medical device is typically implanted or otherwise installed on the body in an accessible area at some distance from the target site, and the medical lead is routed to the target site either through a percutaneous procedure or by surgical implantation depending upon the type and size of the medical lead being implanted.

Because the medical lead extends some distance between the medical device and the target site within the body, the medical lead is subject to forces imposed by movements of the patient. In particular, the medical lead may be subjected to strain. To address the strain, the medical lead may be routed by creating a loop that relieves the strain by the loop making available an additional length of the lead.

While this strain relief loop does relieve the strain, an issue occurs when the patient is subjected to radiofrequency (RF) electromagnetic energy in excess of the ambient, such as when having a magnetic resonance imaging (MRI) scan. The metal conductors within the lead, such as filars and/or a shield, have current induced by the RF energy. This induced current can produce heating within the medical lead but the heating is typically distributed over a length of an MRI conditionally safe lead and is not troublesome. However, with a strain relief loop, the heating tends to be more intense at the intersection point on the loop where the medical lead loops back onto itself. This more intense heating at the intersection point may produce discomfort or injury for the patient.

SUMMARY

Embodiments address issues such as these and others by providing strain relief loop holders for medical leads and systems. The embodiments provide a body section that

covers the intersection point. Some embodiments provide one or more passageways that the lead passes through when forming the strain relief loop. The body section insulates the tissue from the intersection point when constructed of a thermal non-conductor and distributes the heat over a larger amount of tissue to prevent excessive tissue heating when
5 constructed of a thermal conductor. The embodiments may further provide features such as arms or a coil extending from the body section to further define passageways that the medical lead passes through to establish and maintain the strain relief loop. Furthermore, the embodiments may provide for a body that takes the form of a loop or a capsule.

Embodiments provide a strain relief loop holder that includes a body segment
10 defining at least one passageway. A first arm extends from a first end of the body segment. A first arm segment is located at an end of the first arm opposite the body segment, the first arm segment defining a first arm passageway. A second arm extends from a second end of the body segment. A second arm segment is located at the end of the second arm opposite the body segment, the second arm segment defining a second arm
15 passageway.

Embodiments provide a medical lead strain relief system that includes a strain relief loop holder. The strain relief loop holder includes a body segment defining at least one passageway. A first arm extends from a first end of the body segment. A first arm segment is located at an end of the first arm opposite the body segment, the first arm
20 segment defining a first arm passageway. A second arm extends from a second end of the body segment. A second arm segment is located at the end of the second arm opposite the body segment, the second arm segment defining a second arm passageway. The medical lead strain relief system further includes a medical lead that passes through the first arm passageway and the second arm passageway, the medical lead forming a loop by passing
25 through and intersecting within the body segment.

Embodiments provide a medical system that includes a strain relief loop holder. The strain relief holder includes a body segment defining at least one passageway. A first arm extends from a first end of the body segment. A first arm segment is located at an end of the first arm opposite the body segment, the first arm segment defining a first arm
30 passageway. A second arm extends from a second end of the body segment. A second arm segment is located at the end of the second arm opposite the body segment, the second arm segment defining a second arm passageway. The medical system further includes a

medical lead that passes through the first arm passageway and the second arm passageway, the medical lead forming a loop by passing through and intersecting within the body segment. Additionally, the medical system includes a medical device with the medical lead being coupled to the medical device.

5 Embodiments provide a medical lead strain relief system that includes a strain relief loop holder comprising a body defining at least one passageway, the body defining at least one entry to the at least one passageway. The medical lead strain relief system further includes a medical lead that enters and exits the at least one passageway of the body through the at least one entry, the medical lead forming a loop by loosely passing
10 through and intersecting within the body, the at least one passageway being sized larger than the medical lead to allow the medical lead to move unrestricted axially through the at least one lead passageway while being looped loosely through the at least one lead passageway.

15 DESCRIPTION OF THE DRAWINGS

FIG. 1 shows an example of a medical system environment where a strain relief loop is created for a medical lead.

FIG. 2A shows a first example of a strain relief loop holder with a single passageway through a body section.

20 FIG. 2B shows a second example of a strain relief loop holder with a single passageway through a body section.

FIG. 2C shows a third example of a strain relief loop holder with a single passageway through a body section.

25 FIG. 3A shows a first example of a medical lead strain relief system including a fourth example of a strain relief loop holder.

FIG. 3AA shows the first example of the medical lead strain relief system but with two leads present.

FIG. 3B shows a second example of a medical lead strain relief system including a fifth example of a strain relief loop holder.

30 FIG. 4 shows a sixth example of a strain relief loop holder having conductive dopant.

FIG. 5 shows a seventh example of a strain relief loop holder having two passageways within a body section.

FIG. 6 shows a third example of a medical lead strain relief system including the seventh example of the strain relief loop holder.

5 FIG. 7 shows an eighth example of a strain relief loop holder having a metal sleeve within the body section.

FIG. 8 shows a ninth example of a strain relief loop holder having two passageways within the body section with a metal body between the two passageways.

10 FIG. 9 shows a fourth example of a medical lead strain relief system including a tenth example of a strain relief loop holder that is a continuous tube with intermediate apertures.

FIG. 10 shows a fifth example of a medical lead strain relief system including an eleventh example of a strain relief loop holder that is a pair of conjoined continuous tubes.

15 FIG. 11 shows a sixth example of a medical lead strain relief system including a twelfth example of a strain relief loop holder.

FIG. 12 shows a seventh example of a medical lead strain relief system including a twelfth example of a strain relief loop holder.

FIG. 13 shows an eighth example of a medical lead strain relief system including a thirteenth example of a strain relief loop holder.

20 FIG. 14 shows a ninth example of a medical lead strain relief system including a fourteenth example of a strain relief loop holder.

FIG. 15 shows a tenth example of a medical lead strain relief system including a fifteenth example of a strain relief loop holder.

25 FIG. 16 shows an eleventh example of a medical lead strain relief system including a sixteenth example of a strain relief loop holder.

DETAILED DESCRIPTION

Embodiments provide strain relief holders for medical leads to provide protection from excessive heating during exposure to RF energy while also maintaining the strain relief loop. The embodiments include a body section with a passageway that the medical lead passes through and intersects within so that the heating occurs within the body section. In some embodiments, the body section may be a thermal non-conductor and

30

insulates the tissue from the excessive heating. In other embodiments, the body section may be a thermal conductor that distributes the heating over a larger surface area and hence a larger amount of tissue to prevent excessive heating.

FIG. 1 shows a body 112 of a patient who has a medical system 100 implanted for providing stimulation therapy. The medical system 100 includes a medical device 102 that provides stimulation signals. A medical lead 104 is connected to the medical device 102 to deliver the stimulation signals to a distal end where electrodes are present. In this case, the medical lead 104 is a surgically implanted lead with a paddle 106 housing the electrodes for stimulation to the spine.

The medical lead 104 is routed so that a strain relief loop 108 at a location between the proximal end at the medical device 102 and the distal end at the paddle 106. The strain relief loop 108 is assisted in this example by an embodiment of a strain relief holder 200. The strain relief holder 200 holds the lead in the strain relief loop configuration while also protecting the body 112 from heating generated at the intersection point 110 when exposed to RF energy. By maintaining the strain relief loop, an added benefit is that the excessive heating occurring at the intersection point 110 results in lower heating at the target site where the paddle 106 is located.

The strain relief loop holder 200 of this example is shown in FIG. 2A. In this embodiment, the strain relief loop holder 200 includes a body section 202 that defines an entry to and a corresponding lead passageway 207. A first arm 204 extends from the body section 202 on a first end and terminates at a first arm section 208 that defines a lead passageway 209. A second arm 206 extends from the body section 202 on a second end and terminates at a second arm section 210 that defines a lead passageway 211. In this particular example, the first arm 204 and the second arm 206 form an arc even when the medical lead 104 is not present. In other embodiments, the first and second arms 204, 206 may be linear when the lead 104 is not installed as shown in FIG. 2C discussed below but upon looping the medical lead 104 through the strain relief holder 200, the first and second arms 204, 206 attain the arc as shown.

In forming the strain relief loop, the medical lead 104 passes through the arm segments 208, 210 and then intersects itself within the body section 202. Because the medical lead 104 passes through each arm segment 208, 210 only once but passes through the body section 202 twice to create the intersection point, the lead passageway 207 of the

body segment 202 may have a larger diameter than the diameter of the arm segments 208, 210. The diameters may be sized so that the medical lead 104 is able to move axially so that the strain relief function is preserved.

5 The strain relief holder 200 may be constructed of various materials. For instance, the strain relief holder 200 may be constructed of a thermal non-conductor such as a biocompatible polymer, examples including silicone, polyurethane, PEEK, polysulfones, and the like. In that case, the body section 202 insulates the body tissue from heating occurring at an intersection point of the loop within the body section 202. The strain relief holder 200 may instead be constructed of a thermal conductor such as a biocompatible
10 metal, examples including MP35N, titanium, and the like. In that case, the body section 202 distributes the heating throughout the strain relief holder 200, including across all of the body section 202, the arms 204, 206, and the arm sections 208, 210.

This particular example also includes an integral anchor tab 212. The anchor tab 212 provides one or more suture holes 214. These holes 214 allow a surgeon
15 implanting the lead to suture the anchor tab 212, and hence the strain relief loop holder 200 and the medical lead 104 within it, to a particular location within the body 112.

FIG. 2B shows another example of a medical lead strain relief loop holder 220 that may be used in the system of FIG. 1. This example is similar to that of FIG. 2A except that the arms 224 and 226 are positioned on the side of the loop 108 as opposed to the
20 arms 204 and 206 being on the inside of the loop 108. The arm sections 228 and 230 define lead passageways 229 and 221 while the body section 222 defines a lead passageway 227. This example also includes the integral anchor 232 with suture holes 234.

FIG. 2C shows another example of a medical lead strain relief loop holder 240 that may be used in the system of FIG. 1. This example is similar to that of FIG. 2A except
25 that the arms 224 and 226 do not have pre-formed arcs. Instead, the arms 224 and 226 are constructed of an elastic material such as polyurethane or silicone that allows them to achieve an arc upon passing the lead 104 through the lead passageway 247 of the body 242 and through the passageways 241, 249 of the arm sections 248, 250. This
30 example also includes the integral anchor 252 with suture holes 254.

FIG. 3A shows a medical lead strain relief system including a similar strain relief loop holder 300 as that shown in FIG. 2A that may be used in the system of FIG. 1.

FIG. 3AA shows the same example but with two medical leads 104, 105 being looped through the holder 300. It will be appreciated that such a system may instead be designed to accommodate any number of leads passing through. However, this example in FIG. 3AA of two leads 104, 105 passing through a same strain relief loop holder 300 is particularly convenient where a single paddle 106 has two medical lead bodies that interconnect the paddle 106 to the medical device 102. The intersection point 110 for lead 104 in FIG. 3A and for each lead 104, 105 in FIG. 3AA can be seen within a body section 302, where the medical leads 104, 105 pass through a lead passageway 307. In forming two adjacent strain relief loops 108 of FIG. 3AA, the medical leads 104, 105 pass through a lead passageway 311 of an arm section 310 as well as a lead passageway 309 of an arm section 308. The arm sections 308 and 310 are joined to the body section 302 by arms 304 and 306.

FIG. 3B shows another example of a medical lead strain relief loop holder 320 that may be used in the system of FIG. 1. This example is similar to that of FIG. 3A except that the arms 324 and 326 are positioned on the side of the loop 108 as in the example of FIG. 2B as opposed to the arms 304 and 306 being on the inside of the loop 108. The arm sections 328 and 330 define lead passageways 329 and 321 while the body section 322 defines a lead passageway 327.

FIG. 4 shows another example of a strain relief holder 400 that may be used in the system of FIG. 1. Like the prior examples, the strain relief holder 400 includes a body section 402 defining a passageway 407, arms 404, 406 extending from the body section 402, and arm sections 408, 410 defining lead passageways 409, 411. However, in this example, the body section 402 which is constructed of a thermal non-conductor is also doped with a thermally and/or electrically conductive material 412. The conductive material 412 may be thermally conductive to facilitate heat dissipation, such as diamond dust where electrical conductivity is not desired. The conductive material 412 may additionally or alternatively be electrically conductive to alter the transmission-line characteristics at the intersection point 110. Examples of such an electrically conductive dopant material include tantalum or platinum. The dopant conductive material 412 may further enhance the ability of the strain relief loop holder 400 to reduce heating at the electrodes on the distal end of the lead 104. The dopant conductive material 412 may be included in the remainder of the strain relief holder 400 as well. It will be appreciated that

the dopant 412 may be included within all of the various strain relief loop holders disclosed herein.

FIG. 5 shows another example of a strain relief loop holder 500 that may be used in the system of FIG. 1. The strain relief loop holder 500 includes two adjacent passageways 507, 513 established by a body section 502 that includes an extra barrel 503 defining the extra passageway 513. In this example, the arm 504 extends from the body segment 502 and more particularly from the lead passageway 507. The arm 506 extends from the body segment 502 and more particularly from the extra lead passageway 513 defined by the extra barrel 503 of the body segment 502. In this example, an arm segment 508 defines a lead passageway 509 that is aligned with the lead passageway 507 while the arm segment 510 defines a lead passageway 511 that is aligned with the lead passageway 513.

FIG. 6 shows a medical lead strain relief system that may be used in the system of FIG. 1 and that includes the medical lead 104 looping through a strain relief loop holder 600 like that of FIG. 5. The medical lead 104 passes through a lead passageway 613 defined by the extra barrel 603, then loops through a lead passageway 611 of an arm segment 610 of an arm 606 extending from the extra barrel 603. The medical lead 104 loops through a lead passageway 609 of an arm section 608 of an arm 604 extending from the body section 602.

In this embodiment of the strain relief holder 600, the intersection point 110' differs in that the medical lead 104 does not directly contact itself. Instead, the medical lead 104 is separated from itself at the intersection point 110' passing through separate lead passageways 607, 613 of the body segment 602. This separation may reduce the degree of excessive heating at the intersection point 110'. Meanwhile, in embodiments where the body segment 602 is thermally non-conductive, the body segment 602 continues to isolate the excess heating from the body 112. For embodiments where the body segment 602 is thermally conductive, the body segment 602 continues to distribute the heating of the intersection point 110' over a larger amount of tissue.

FIG. 7 shows another example of a strain relief loop holder 700 that may be used in the system of FIG. 1. The arms 704, 706 are abbreviated and arm segments are omitted from this figure for purposes of illustration of the perspective view. In this example, a body section 702 is constructed of a thermal non-conductor such as a polymer. However,

a metal insert 712 such as a metal sleeve is embedded within the body section such that the medical lead passes through the metal insert 712 when passing through the passageway 707. This metal insert 712 enhances the benefit from heating at the intersection point within the body section 702 which further reduces the heating at the electrodes on the distal end of the medical lead 104. Examples of materials for the metal sleeve 712 include titanium, MP35N, and the like.

FIG. 8 shows another example of a strain relief loop holder 800 that may be used in the system of FIG. 1. The arms 804, 806 are abbreviated and arm segments are omitted from this figure for purposes of illustration of the perspective view. In this example, a body section 802 including an extra barrel 803 is constructed of a thermal non-conductor such as a polymer. However, a metal body 812 is embedded within the body section 802 between the two barrels such that the medical lead 104 passes through the lead passageways 807, 813 and the metal body 812 is present between the passes of the medical lead 104 at the intersection point. This metal body 812 also enhances the benefit from heating at the intersection point within the body section 802 which further reduces the heating at the electrodes on the distal end of the medical lead 104. Examples of materials for the metal body 812 include titanium, MP35N, and the like.

FIG. 9 shows another example of a strain relief loop holder 900 that may be used in the system of FIG. 1. This strain relief loop holder 900 is a continuous tube with a center section 902 and end sections 904, 906 together defining a lead passageway 907. The intersection point of the medical lead 104 occurs within the center section 902 and therefore the center section 902 may have a larger diameter than the end sections 904 906. The center section 902 may also define apertures 908 and 910 that provide an entry to allow the medical lead 104 to enter and exit the strain relief loop holder. This example may be constructed of thermal non-conductors or thermal conductors. Furthermore, in the case of thermal non-conductor construction, a dopant or metal insert may be included as discussed above in relation to FIGS. 4 and 7.

FIG. 10 shows another example of a strain relief loop holder 1000 that may be used in the system of FIG. 1. The strain relief loop holder 1000 utilizes continuous conjoined tubes forming center sections 1002 and 1003 and end sections 1004 and 1006 defining lead passageways 1004, 1009, respectively. In this case, each tube contains a single pass of the medical lead 104 and therefore both the center sections 1002, 1003 and

the end sections 1004, 1006 are the same diameter in this example. This example may also be constructed of thermal non-conductors or thermal conductors. Furthermore, in the case of thermal non-conductor construction, a dopant, metal insert, or metal body may be included as discussed above in relation to FIGS. 4, 7, and 8.

5 FIG. 11 shows another example of a strain relief loop holder 1100 that may be used in the system of FIG. 1 and that utilizes a body 1102 with a single tube. In this case, the tube 1102 defines a lead passageway 1104. As in the prior examples, the lead 104 passes through the lead passageway 1104 loosely to form the strain relief loop 108 and intersection point 110 where the diameter of the lead passageway 1104 is larger than the
10 lead body 104 to allow unrestricted axial movement of the lead 104 through the passageway 1104. This example may also be constructed of thermal non-conductors or thermal conductors. Furthermore, in the case of thermal non-conductor construction, a dopant, metal insert, or metal body may be included as discussed above in relation to FIGS. 4, 7, and 8.

15 FIG. 12 shows another example of a strain relief loop holder 1200 that may be used in the system of FIG. 1 and that utilizes a body 1202 that includes an additional tube 1203 to thereby form two adjacent central sections. In this case, the body 1202 including the additional tube 1203 defines lead passageways 1204 and 1206. As in the prior examples, the lead 104 passes through the lead passageways 1204, 1206 loosely to
20 form the strain relief loop 108 and intersection point 110' where the diameter of the lead passageways 1204, 1206 are larger than the lead body 104 to allow unrestricted axial movement of the lead 104 through the passageways 1204, 1206. This example may also be constructed of thermal non-conductors or thermal conductors. Furthermore, in the case of thermal non-conductor construction, a dopant, metal insert, or metal body may be
25 included as discussed above in relation to FIGS. 4, 7, and 8.

 FIG. 13 shows another example of a strain relief loop holder 1300 that may be used in the system of FIG. 1 and that utilizes a body 1302 with a single tubular central section that defines two lead passageways 1304, 1306. As in the prior examples, the lead 104 passes through the lead passageways 1304, 1306 loosely to form the strain relief
30 loop 108 where the diameter of the lead passageways 1304, 1306 is larger than the lead body 104 to allow unrestricted axial movement of the lead 104 through the passageways 1304, 1306. This example may also be constructed of thermal non-

conductors or thermal conductors. Furthermore, in the case of thermal non-conductor construction, a dopant, metal insert, or metal body may be included as discussed above in relation to FIGS. 4, 7, and 8.

5 FIG. 14 shows another example of a strain relief loop holder 1400 that may be used in the system of FIG. 1. The strain relief loop holder 1400 utilizes a body 1402 with a single tube to define a lead passageway 1404 at the intersection point 110 but also utilizes a looped coil 1406. As in the prior examples, the lead 104 passes through the lead passageway 1404 loosely to form the strain relief loop 108 where the diameter of the lead passageway 1404 is larger than the lead body 104 to allow unrestricted axial movement of the lead 104 through the passageway 1404. The loop 108 is constrained to a particular shape and size by the presence of the looped coil 1406 which is coupled to the body 1402. The looped coil 1406 may be constructed of non-conductive materials such as polyurethane, silicone, or conductive materials that have a non-conductive coating such as ETFE coated titanium, titanium molybdenum, or MP35N. This example may also be constructed of thermal non-conductors or thermal conductors. Furthermore, in the case of thermal non-conductor construction, a dopant, metal insert, or metal body may be included as discussed above in relation to FIGS. 4, 7, and 8.

15 FIG. 15 shows another example of a strain relief loop holder 1500 that may be used in the system of FIG. 1 and that utilizes a body 1502 that provides a single tube. In this case, the body 1502 defines a lead passageway 1504. Additionally, the body 1502 is also looped. As in the prior examples, the lead 104 passes through the lead passageway 1504 loosely with the lead passageway 1504 to form the strain relief loop 108 where the diameter of the lead passageway 1504 is larger than the lead body 104 to allow unrestricted axial movement of the lead 104 through the passageway 1504. The looped shape of the body 1502 constrains the shape and size of the loop 108 of the lead 104. This example may also be constructed of thermal non-conductors or thermal conductors. Furthermore, in the case of thermal non-conductor construction, a dopant, metal insert, or metal body may be included as discussed above in relation to FIGS. 4, 7, and 8.

25 FIG. 16 shows another example of a strain relief loop holder 1600 that may be used in the system of FIG. 1. The strain relief loop holder 1600 utilizes a body 1602 that forms a capsule to completely house the loop 108 of the lead 104 such that the passageway for the lead 104 is the entire internal volume of the strain relief loop holder 1600. The

lead enters and exits the body 1602 through apertures 1604 and 1606 forming an entry to the interior volume of the body 1602. This example may also be constructed of thermal non-conductors or thermal conductors. Furthermore, in the case of thermal non-conductor construction, a dopant, metal insert, or metal body may be included as discussed above in relation to FIGS. 4, 7, and 8.

In each of the examples of the strain relief loop holder, the lead body 104 could be affixed to one side of the holder so that the holder and the lead 104 are inseparable. In this case, the strain relief holder is already present on the lead 104 at the time of implant so that the holder is not inadvertently or intentionally omitted during the implantation procedure. By affixing one side of the holder to the lead, the strain relief function is preserved. For example, both leads 104, 105 may be affixed to the arm section 310 such as by a bond created by an adhesive or by melding the lead body to the arm section by reflowing the polymers of the two at that point.

While embodiments have been particularly shown and described, it will be understood by those skilled in the art that various other changes in the form and details may be made therein without departing from the spirit and scope of the invention.

What is claimed is:

1. A strain relief loop holder, comprising:
 - a body segment defining at least one passageway;
 - a first arm extending from a first end of the body segment;
 - 5 a first arm segment at an end of the first arm opposite the body segment, the first arm segment defining a first arm passageway;
 - a second arm extending from a second end of the body segment; and
 - a second arm segment at the end of the second arm opposite the body segment, the second arm segment defining a second arm passageway.
- 10 2. The strain relief loop holder of claim 1, wherein the first arm and second arm have an arc shape.
3. The strain relief loop holder of either claim 1 or 2, wherein the body segment
15 defines a single passageway and wherein both the first arm and the second arm extend from the single passageway.
4. The strain relief loop holder of either claim 1 or 2, wherein the body segment
20 defines a first passageway and a second passageway, wherein the first arm extends from the first passageway, and wherein the second arm extends from the second passageway.
5. The strain relief loop holder of claim 4, further comprising a metal body between the first and second passageways.
- 25 6. The strain relief loop holder of any of claims 1-4, wherein the body segment, first arm, and second arm are constructed of a polymer.
7. The strain relief loop holder of claim 6, wherein the body segment is doped with a
30 conductive material.
8. The strain relief loop holder of claim 6, further comprising a metal insert within the body segment.

9. The strain relief loop holder of any of claims 1-4, wherein the body segment, first arm, and second arm are constructed of a metal.
- 5 10. The strain relief loop holder of any of claims 1-9, further comprising an anchor tab extending from the body segment.
11. The strain relief loop holder of any of claims 1-10, wherein the at least one body segment passageway has a diameter greater than a diameter of the first arm passageway and second arm passageway.
- 10 12. A medical lead strain relief system, comprising:
a strain relief loop holder comprising:
a body segment defining at least one passageway;
15 a first arm extending from a first end of the body segment;
a first arm segment at an end of the first arm opposite the body segment, the first arm segment defining a first arm passageway;
a second arm extending from a second end of the body segment; and
a second arm segment at the end of the second arm opposite the body segment, the
20 second arm segment defining a second arm passageway; and
a medical lead that passes through the first arm passageway and the second arm passageway, the medical lead forming a loop by passing through and intersecting within the body segment.
- 25 13. The medical strain relief system of claim 12, wherein the first arm and second arm have an arc shape.
14. The medical lead strain relief system of either claim 12 or 13, wherein the body segment defines a single passageway, wherein both the first arm and the second arm extend from the single passageway, and wherein the medical lead intersects within the
30 single passageway.

15. The medical lead strain relief system of either claim 12 or 13, wherein the body segment defines a first passageway adjacent to a second passageway, wherein the first arm extends from the first passageway, and wherein the second arm extends from the second passageway, and wherein the medical lead intersects within the body segment by passing through both the first and second passageways.
16. The medical lead strain relief system of any of claims 12-15, wherein the body segment, first arm, and second arm are constructed of a polymer.
17. The medical lead strain relief system of claim 16, wherein the body segment is doped with a conductive material.
18. The medical lead strain relief system of any of claims 12-15, wherein the body segment, first arm, and second arm are constructed of a metal.
19. The medical lead strain relief system of any of claims 12-18, further comprising an anchor tab extending from the body segment.
20. The medical lead strain relief system of any of claims 12-19, wherein the at least one body segment passageway has a diameter greater than a diameter of the first arm passageway and second arm passageway.
21. A medical system, comprising:
a strain relief loop holder comprising:
a body segment defining at least one passageway;
a first arm extending from a first end of the body segment;
a first arm segment at an end of the first arm opposite the body segment, the first arm segment defining a first arm passageway;
a second arm extending from a second end of the body segment; and
a second arm segment at the end of the second arm opposite the body segment, the second arm segment defining a second arm passageway;

a medical lead that passes through the first arm passageway and the second arm passageway, the medical lead forming a loop by passing through and intersecting within the body segment; and

a medical device with the medical lead being coupled to the medical device.

5

22. The medical system of claim 21, wherein the first arm and the second arm have an arc shape.

10

23. The medical system of either claim 21 or 22, wherein the body segment defines a single passageway, wherein both the first arm and the second arm extend from the single passageway, and wherein the medical lead intersects within the single passageway.

15

24. The medical system of either claim 21 or 22, wherein the body segment defines a first passageway adjacent to a second passageway, wherein the first arm extends from the first passageway, and wherein the second arm extends from the second passageway, and wherein the medical lead intersects within the body segment by passing through both the first and second passageways.

20

25. The medical system of any of claims 21-24, wherein the body segment, first arm, and second arm are constructed of a polymer.

26. The medical system of claim 25, wherein the body segment is doped with a conductive material.

25

27. The medical system of any of claims 21-24, wherein the body segment, first arm, and second arm are constructed of a metal.

30

28. The medical system of any of claims 21-27, further comprising an anchor tab extending from the body segment.

29. The medical system of any of claims 21-28, wherein the at least one body segment passageway has a diameter greater than a diameter of the first arm passageway and second arm passageway.

5 30. A medical lead strain relief system, comprising:
a strain relief loop holder comprising a body defining at least one passageway, the body defining at least one entry to the at least one passageway;

10 a medical lead that enters and exits the at least one passageway of the body through the at least one entry, the medical lead forming a loop by loosely passing through and intersecting within the body, the at least one passageway being sized larger than the medical lead to allow the medical lead to move unrestricted axially through the at least one lead passageway while being looped loosely through the at least one lead passageway.

15 31. The medical lead strain relief system of claim 30, wherein the body has an arc shape.

32. The medical lead strain relief system of claim 30, wherein the body forms a loop.

20 33. The medical lead strain relief system of claim 30, wherein the body forms a capsule.

25 34. The medical lead strain relief system of claim 30, wherein the body includes two lead passageways and wherein the medical lead forms a loop by passing through the two lead passageways.

30 35. The medical lead strain relief system of claim 34, wherein the body defines the two passageways by having two adjacent central sections, and wherein the medical lead forms the loop by passing through the two passageways of the body and establishes an intersection point within the body at the two adjacent central sections.

36. The medical lead strain relief system of claim 34, wherein the body defines the two passageways within one central section, and wherein the medical lead forms the loop by

passing through the two passageways of the body and establishes an intersection point within the one central section.

5 37. The medical lead strain relief system of claim 30, further comprising a looped coil coupled to the body and wherein the medical lead passes through the looped coil.

38. The medical lead of any of claims 30-37, wherein the body comprises a thermal non-conductor.

10 39. The medical lead of any of claims 30-37, wherein the body comprises a thermal conductor.

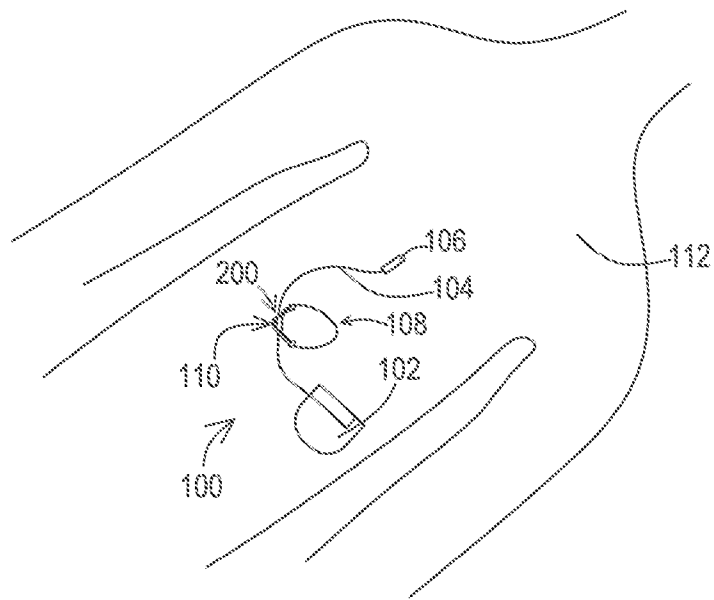

FIG. 1

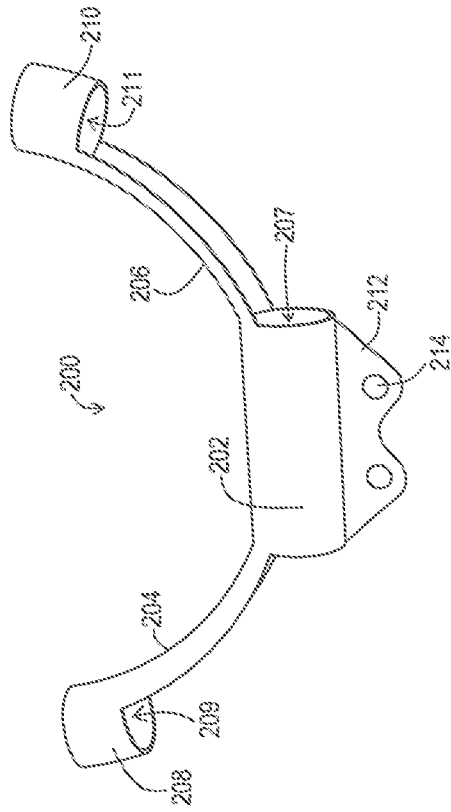

FIG. 2A

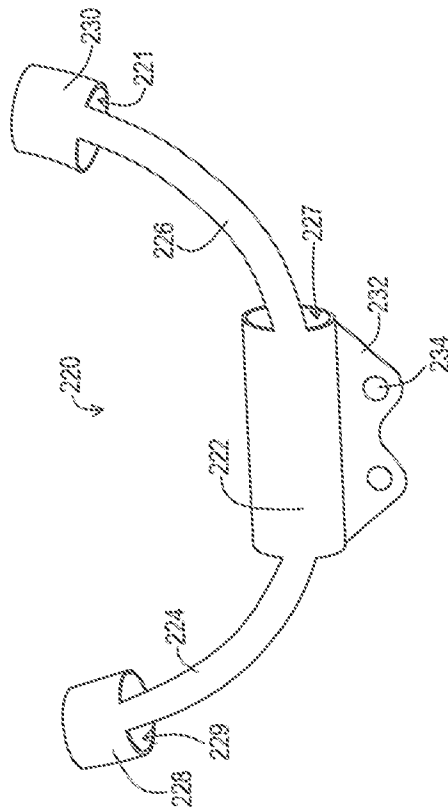

FIG. 2B

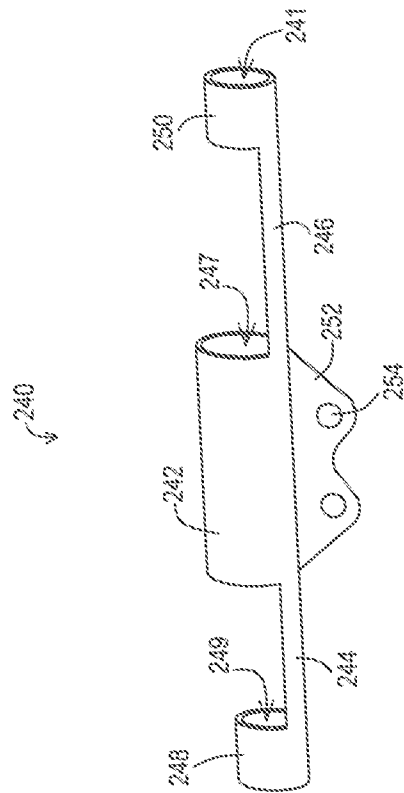

FIG. 2C

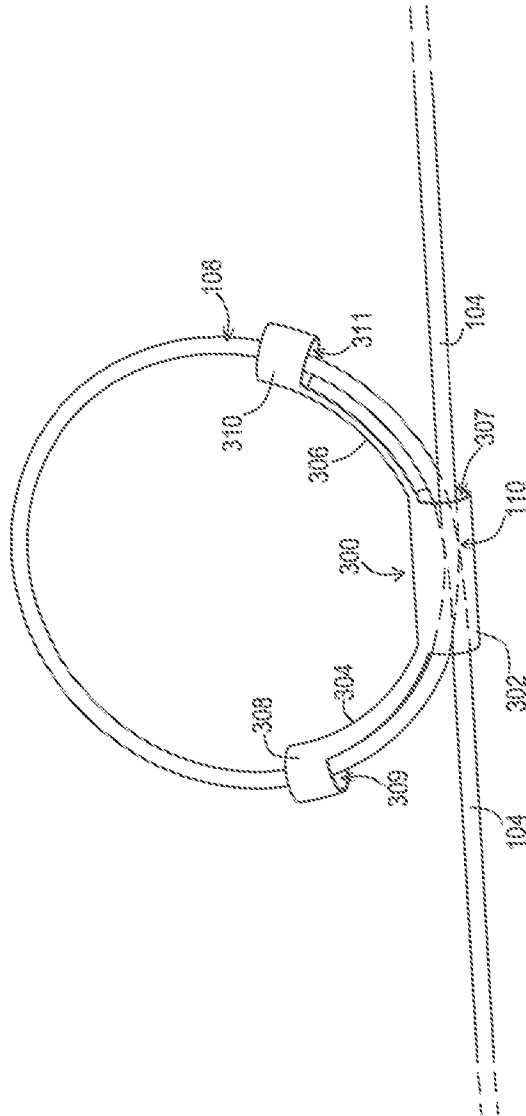

FIG. 3A

6/19

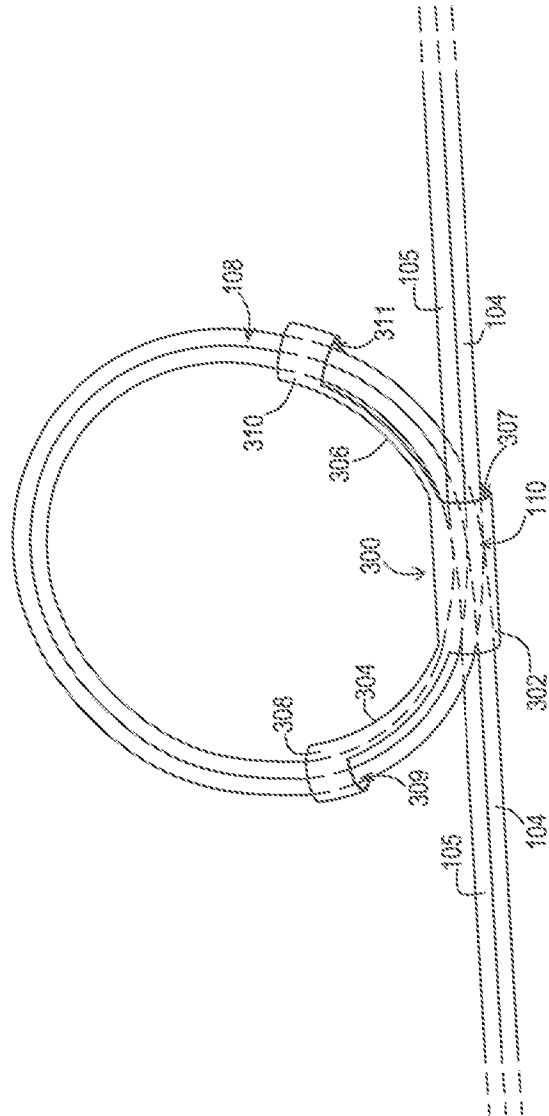

FIG. 3AA

7/19

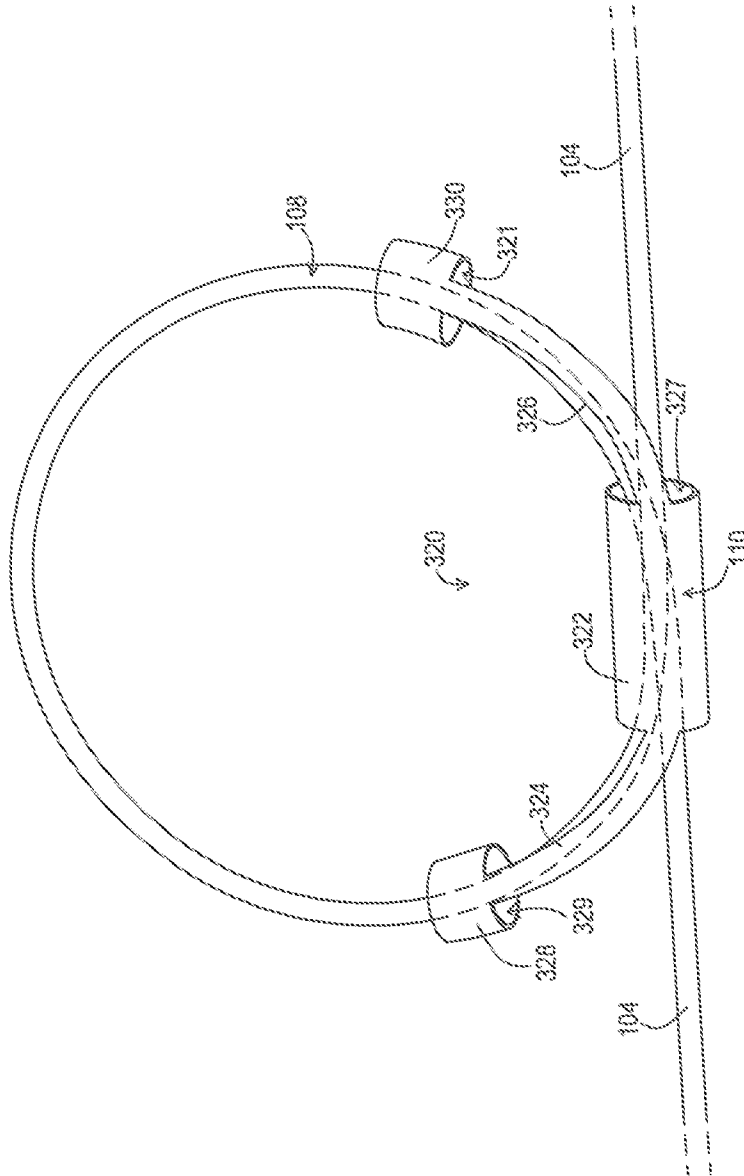

FIG. 3B

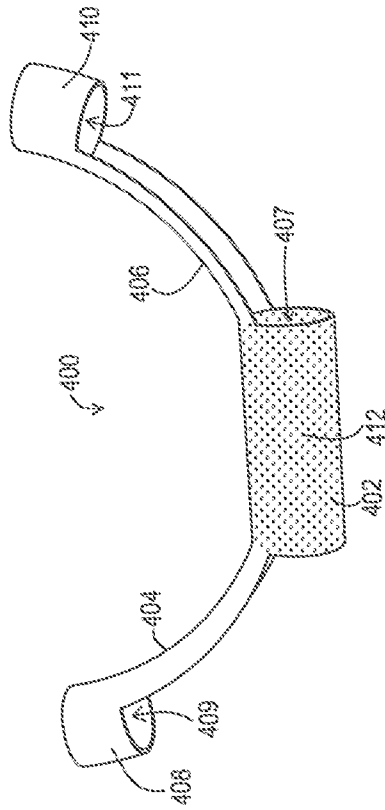

FIG. 4

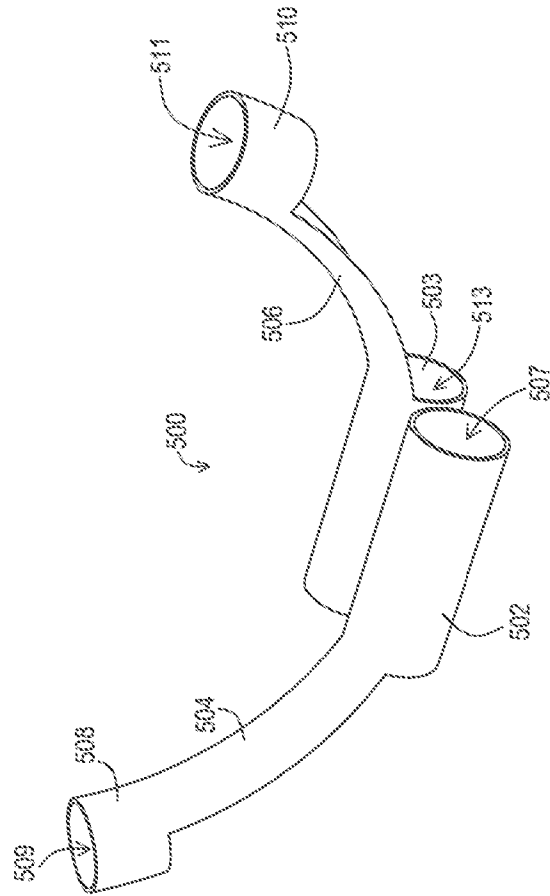

FIG. 5

INTERNATIONAL SEARCH REPORT

International application No
PCT/US2013/023643

A. CLASSIFICATION OF SUBJECT MATTER
 INV. A61N1/05 A61M25/02 G01K1/14 H01R13/58
 ADD.
 According to International Patent Classification (IPC) or to both national classification and IPC

B. FIELDS SEARCHED
 Minimum documentation searched (classification system followed by classification symbols)
 A61N A61M G01K H01R

Documentation searched other than minimum documentation to the extent that such documents are included in the fields searched

Electronic data base consulted during the international search (name of data base and, where practicable, search terms used)
 EPO-Internal, WPI Data

C. DOCUMENTS CONSIDERED TO BE RELEVANT

Category*	Citation of document, with indication, where appropriate, of the relevant passages	Relevant to claim No.
X	US 5 376 108 A (COLLINS KENNETH A [US] ET AL) 27 December 1994 (1994-12-27) abstract; claim *; figures 1-9 column 3 columns 5-8	1-39
A	US 2012/089129 A1 (ENGELHARDT BERNARD [CA]) 12 April 2012 (2012-04-12) the whole document	1-39
A	WO 2008/072946 A1 (MEDIC DOMAIN M SDN BHD [MY]; LEE CHOOI TIAN [MY]; CHAN JAN KOW [MY]) 19 June 2008 (2008-06-19) the whole document	1-39
A	US 6 471 676 B1 (DELEGGE REBECCA [US] ET AL) 29 October 2002 (2002-10-29) the whole document	1-39

Further documents are listed in the continuation of Box C.

See patent family annex.

* Special categories of cited documents :

- "A" document defining the general state of the art which is not considered to be of particular relevance
- "E" earlier application or patent but published on or after the international filing date
- "L" document which may throw doubts on priority claim(s) or which is cited to establish the publication date of another citation or other special reason (as specified)
- "O" document referring to an oral disclosure, use, exhibition or other means
- "P" document published prior to the international filing date but later than the priority date claimed

- "T" later document published after the international filing date or priority date and not in conflict with the application but cited to understand the principle or theory underlying the invention
- "X" document of particular relevance; the claimed invention cannot be considered novel or cannot be considered to involve an inventive step when the document is taken alone
- "Y" document of particular relevance; the claimed invention cannot be considered to involve an inventive step when the document is combined with one or more other such documents, such combination being obvious to a person skilled in the art
- "&" document member of the same patent family

Date of the actual completion of the international search 18 April 2013	Date of mailing of the international search report 26/04/2013
---	---

Name and mailing address of the ISA/ European Patent Office, P.B. 5818 Patentlaan 2 NL - 2280 HV Rijswijk Tel. (+31-70) 340-2040, Fax: (+31-70) 340-3016	Authorized officer Scheffler, Arnaud
--	--

INTERNATIONAL SEARCH REPORT

Information on patent family members

International application No PCT/US2013/023643

Patent document cited in search report	Publication date	Patent family member(s)	Publication date
US 5376108	A	27-12-1994	NONE
US 2012089129	A1	12-04-2012	NONE
WO 2008072946	A1	19-06-2008	CN 101605570 A 16-12-2009
			US 2010217201 A1 26-08-2010
			WO 2008072946 A1 19-06-2008
US 6471676	B1	29-10-2002	NONE