



(19) **United States**

(12) **Patent Application Publication**
Partridge et al.

(10) **Pub. No.: US 2007/0170530 A1**

(43) **Pub. Date: Jul. 26, 2007**

(54) **WAFER ENCAPSULATED
MICROELECTROMECHANICAL
STRUCTURE AND METHOD OF
MANUFACTURING SAME**

Publication Classification

(51) **Int. Cl.**
H01L 29/84 (2006.01)
H01L 21/00 (2006.01)

(76) **Inventors:** **Aaron Partridge**, Cupertino, CA (US); **Markus Lutz**, Los Altos, CA (US); **Pavan Gupta**, Belmont, CA (US)

(52) **U.S. Cl.** **257/415; 257/419; 438/53**

Correspondence Address:
NEIL A. STEINBERG
2665 MARINE WAY, SUITE 1150
MOUNTAIN VIEW, CA 94043

(57) **ABSTRACT**

There are many inventions described and illustrated herein. In one aspect, the present inventions relate to devices, systems and/or methods of encapsulating and fabricating electromechanical structures or elements, for example, accelerometer, gyroscope or other transducer (for example, pressure sensor, strain sensor, tactile sensor, magnetic sensor and/or temperature sensor), filter or resonator. The fabricating or manufacturing microelectromechanical systems of the present invention, and the systems manufactured thereby, employ wafer bonding encapsulation techniques.

(21) **Appl. No.: 11/545,113**
(22) **Filed: Oct. 6, 2006**

Related U.S. Application Data

(62) Division of application No. 11/336,521, filed on Jan. 20, 2006.

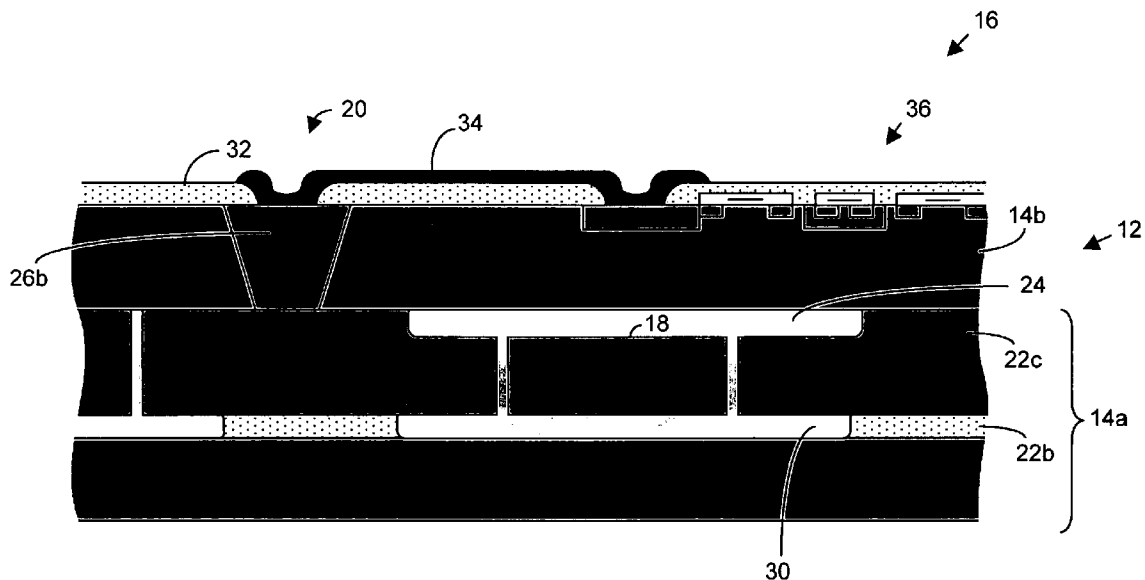

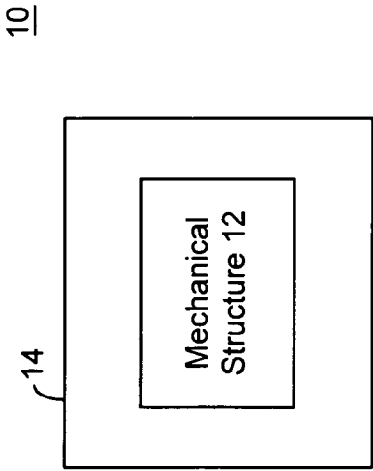

FIGURE 1A

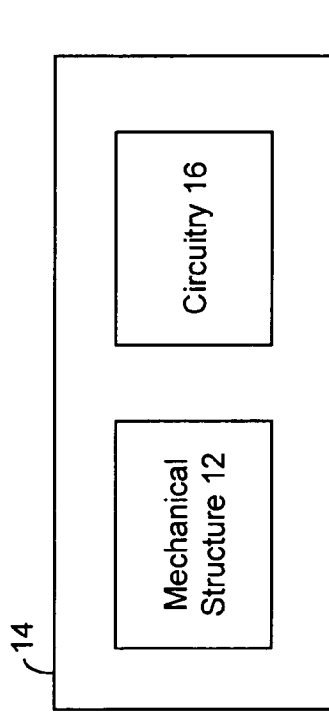

FIGURE 1B

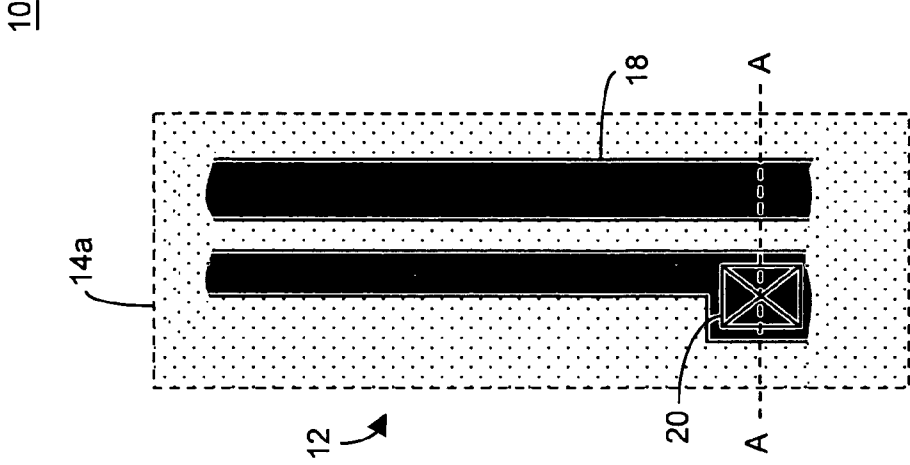

FIGURE 2

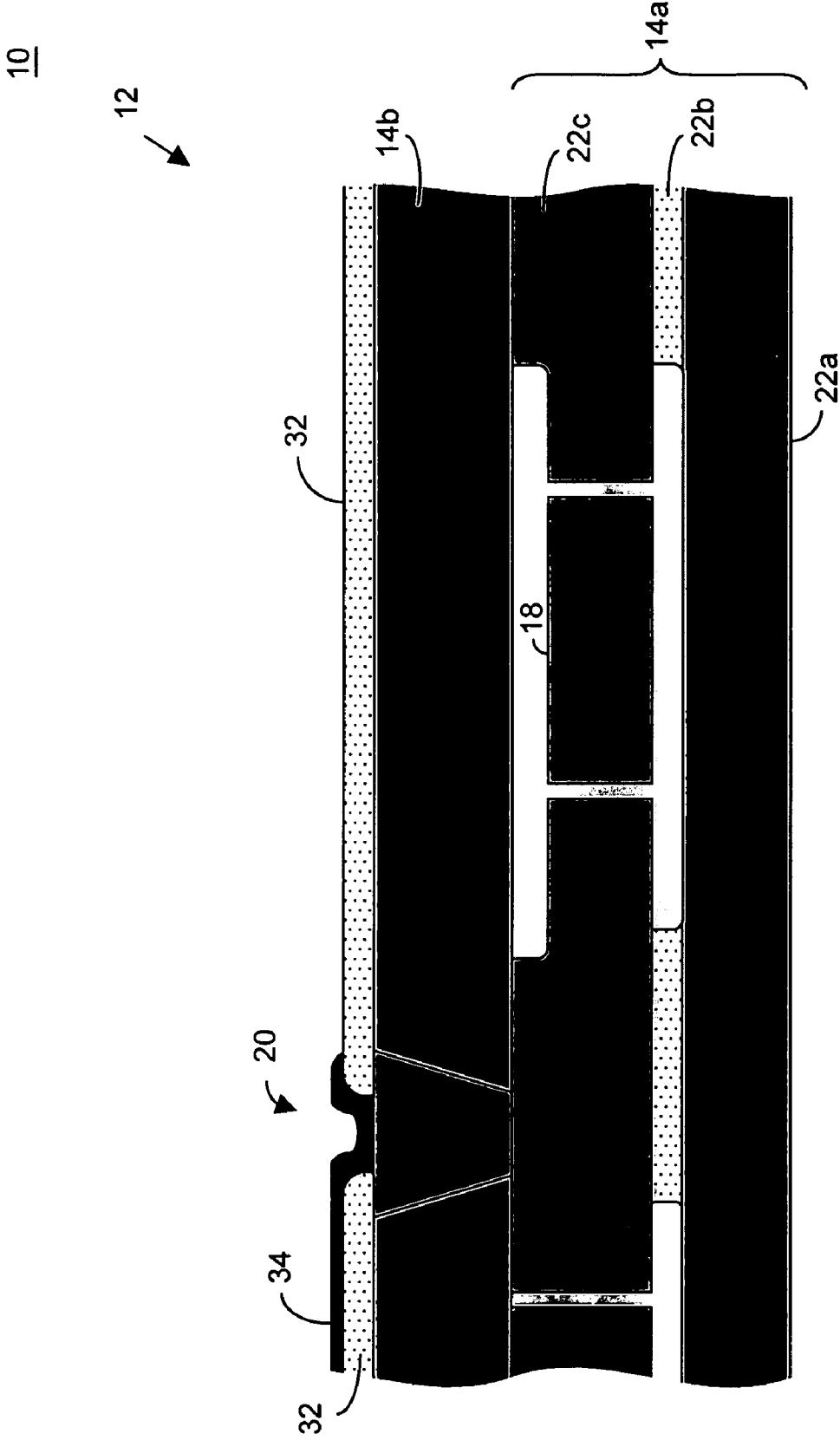

FIGURE 3

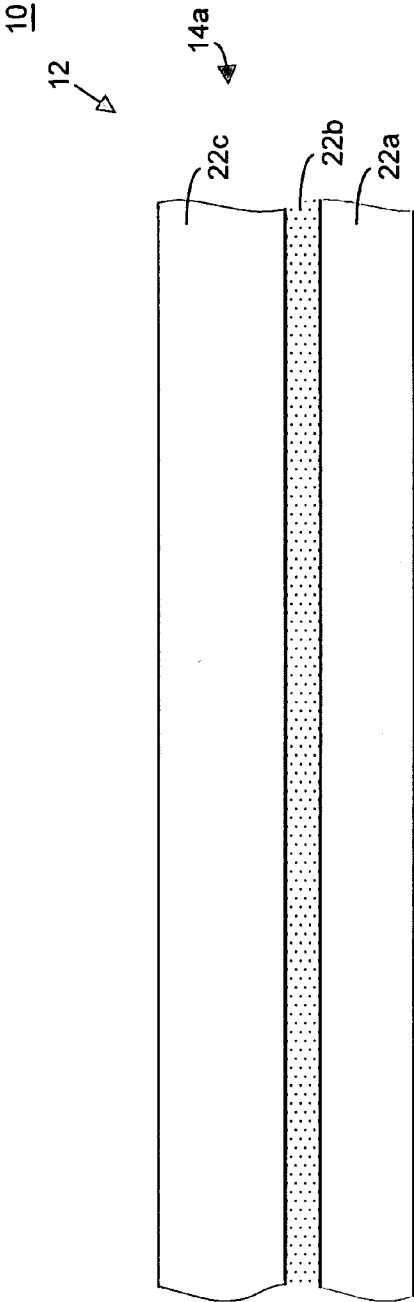

FIGURE 4A

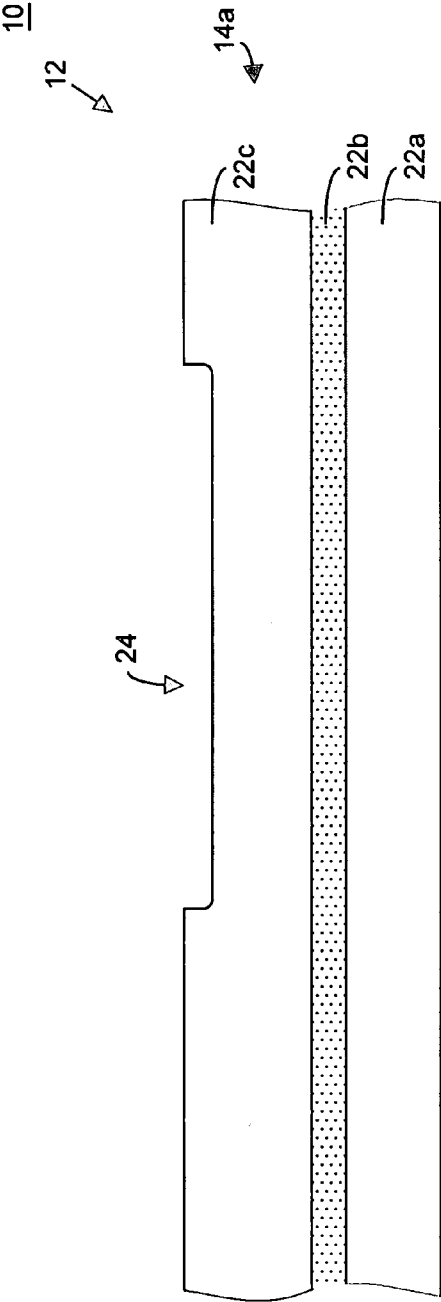

FIGURE 4B

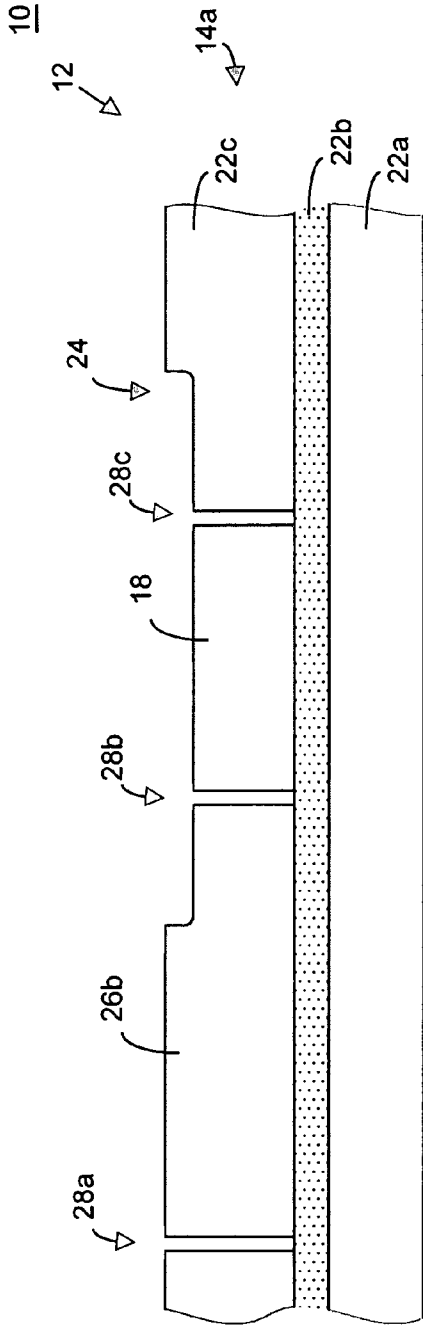

FIGURE 4C

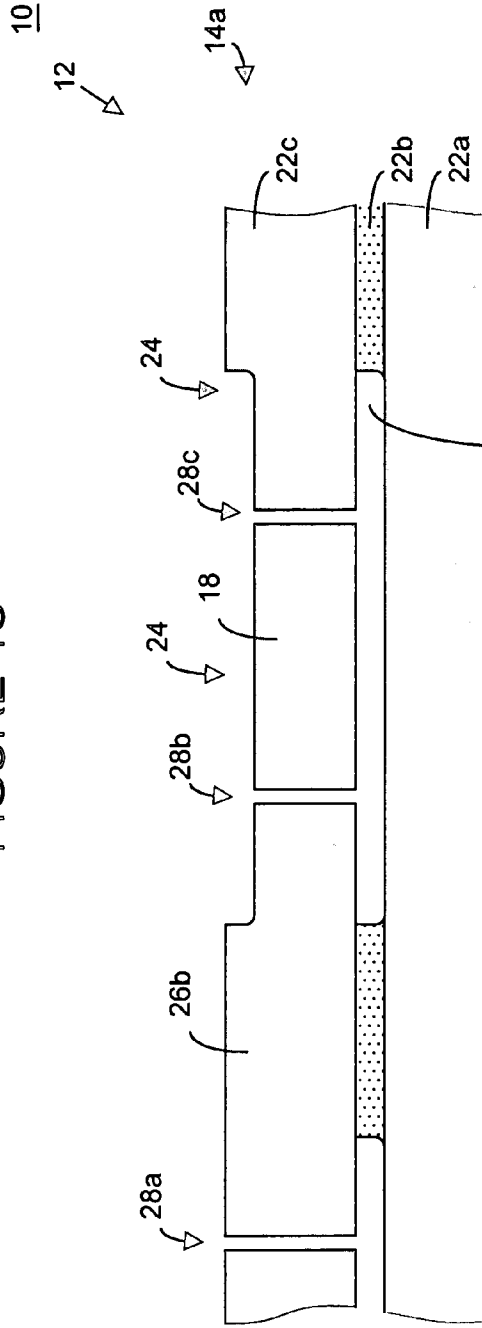

FIGURE 4D

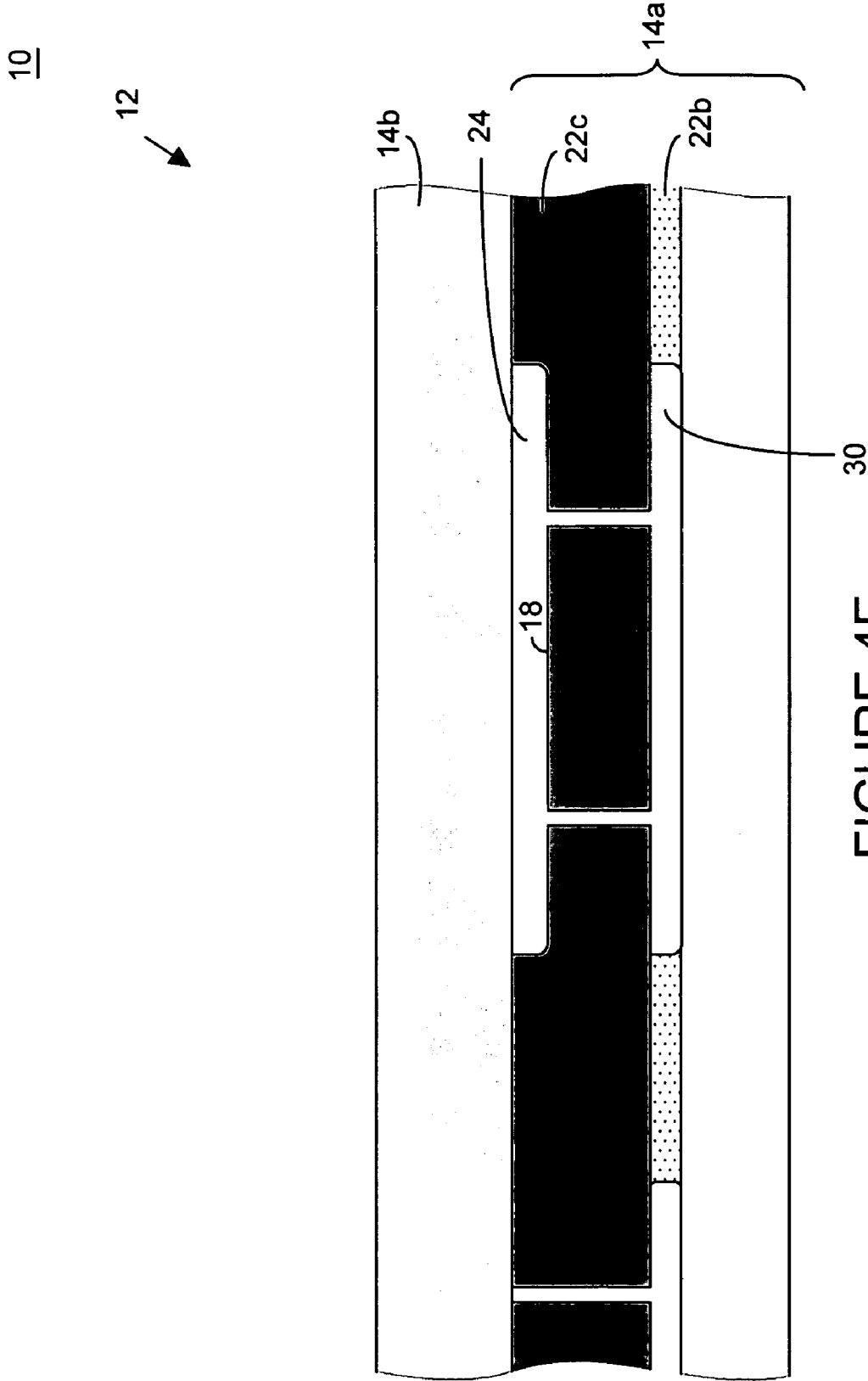

FIGURE 4E

10

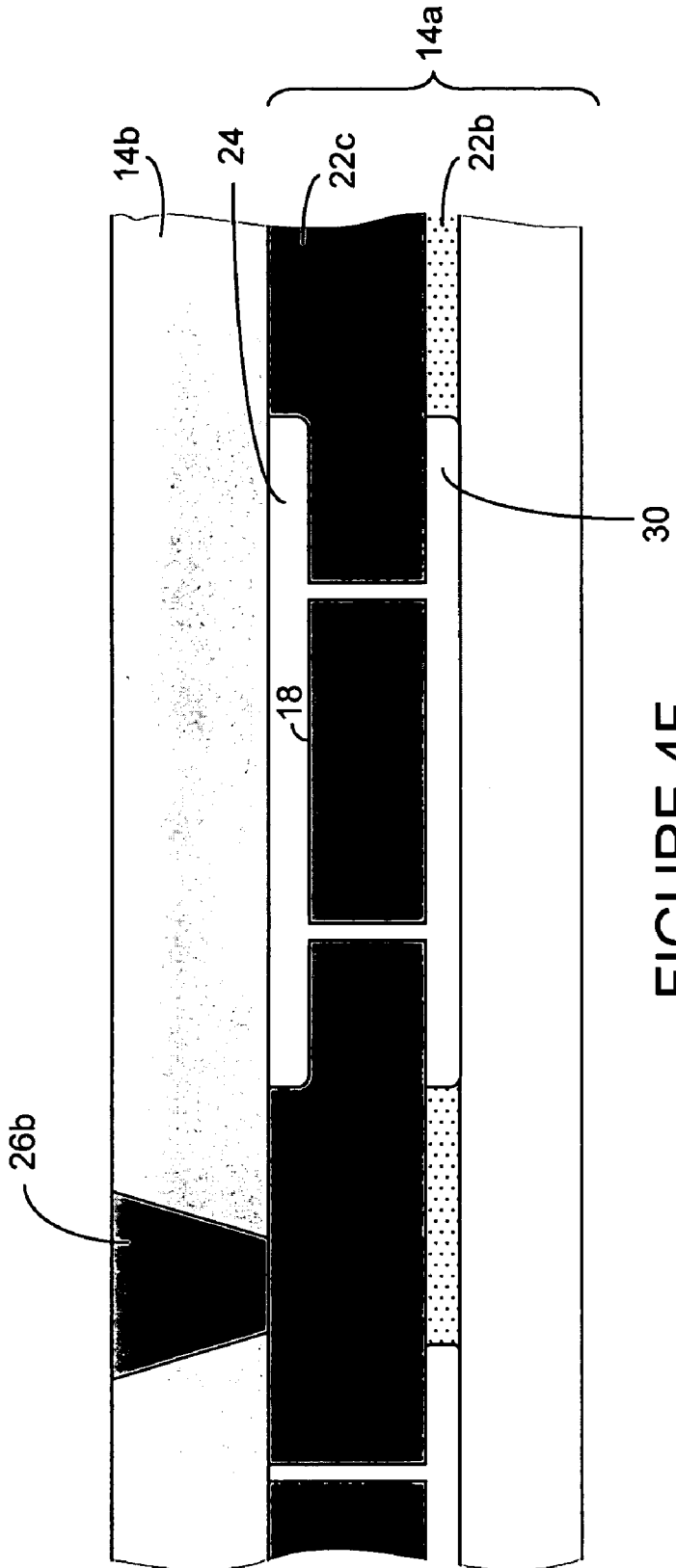

FIGURE 4F

10

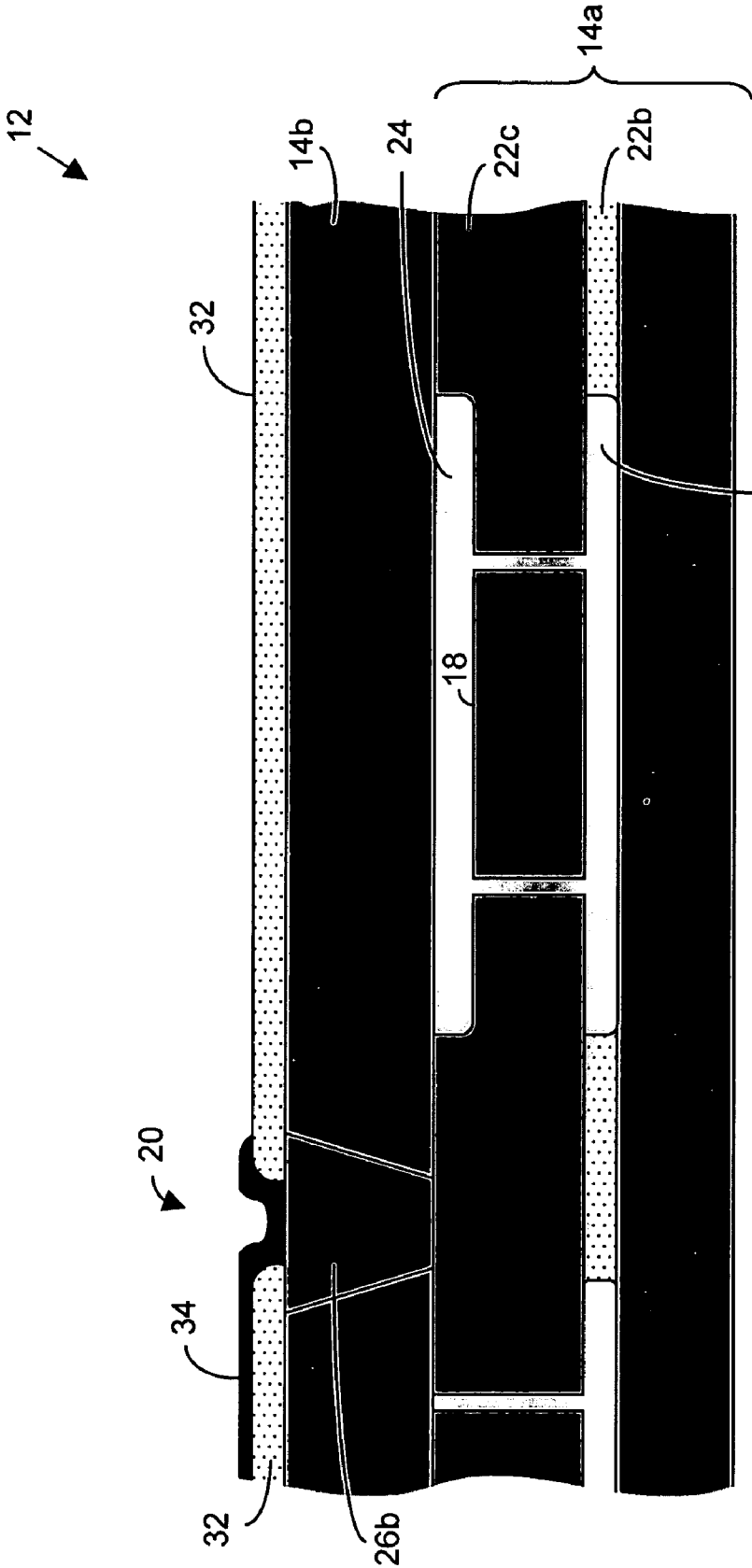

FIGURE 4G

10

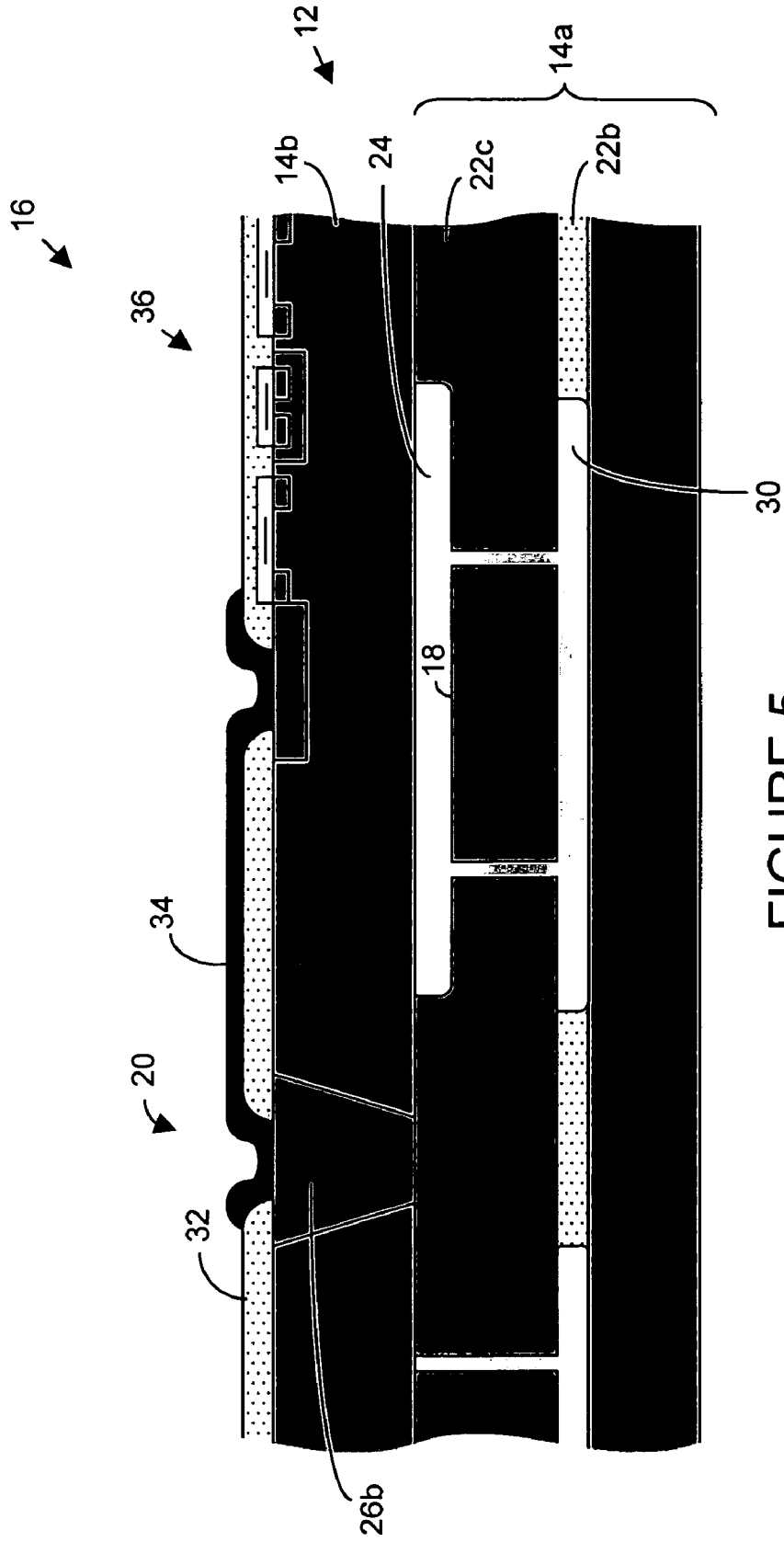

FIGURE 5

10

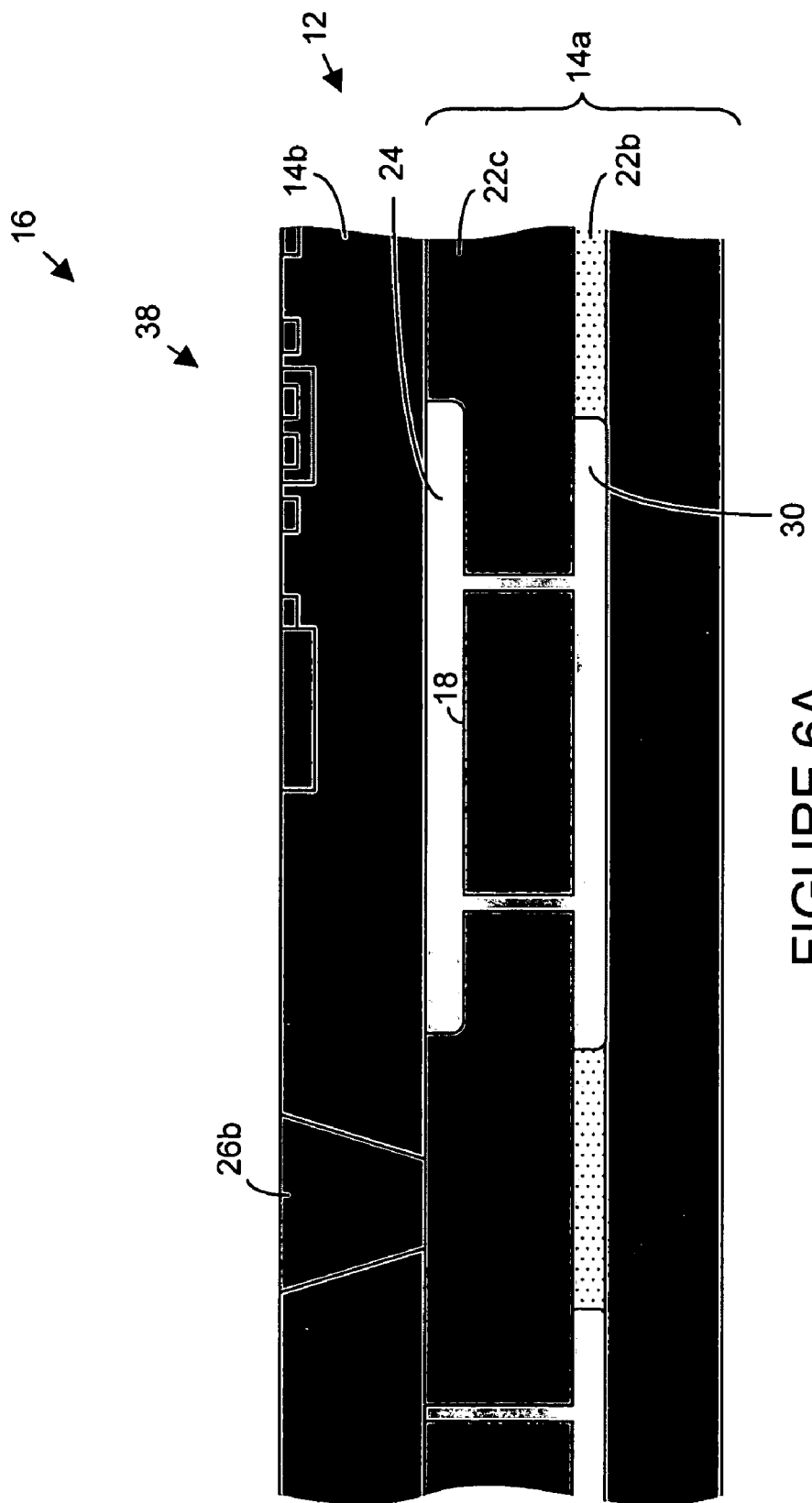

FIGURE 6A

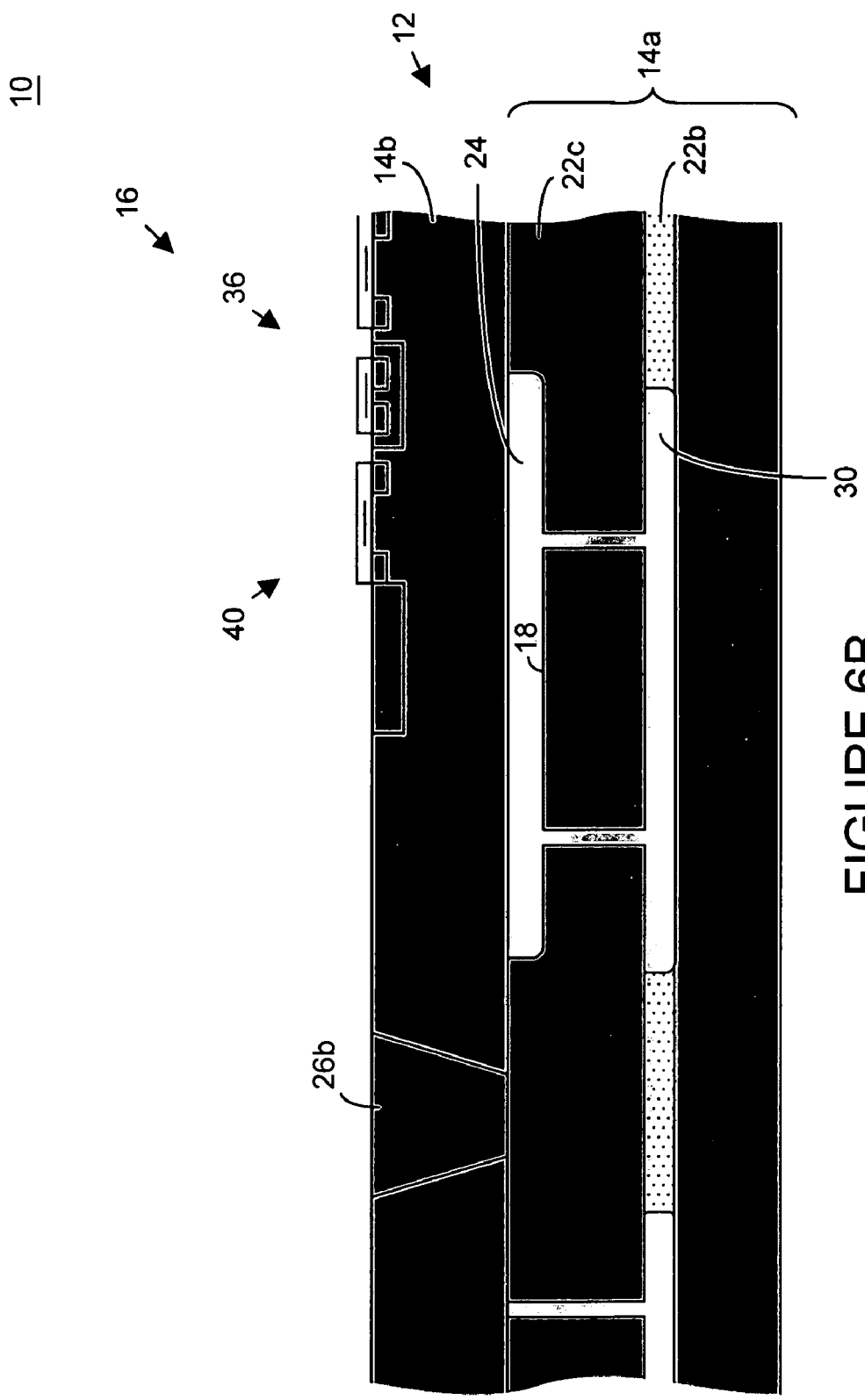

FIGURE 6B

10

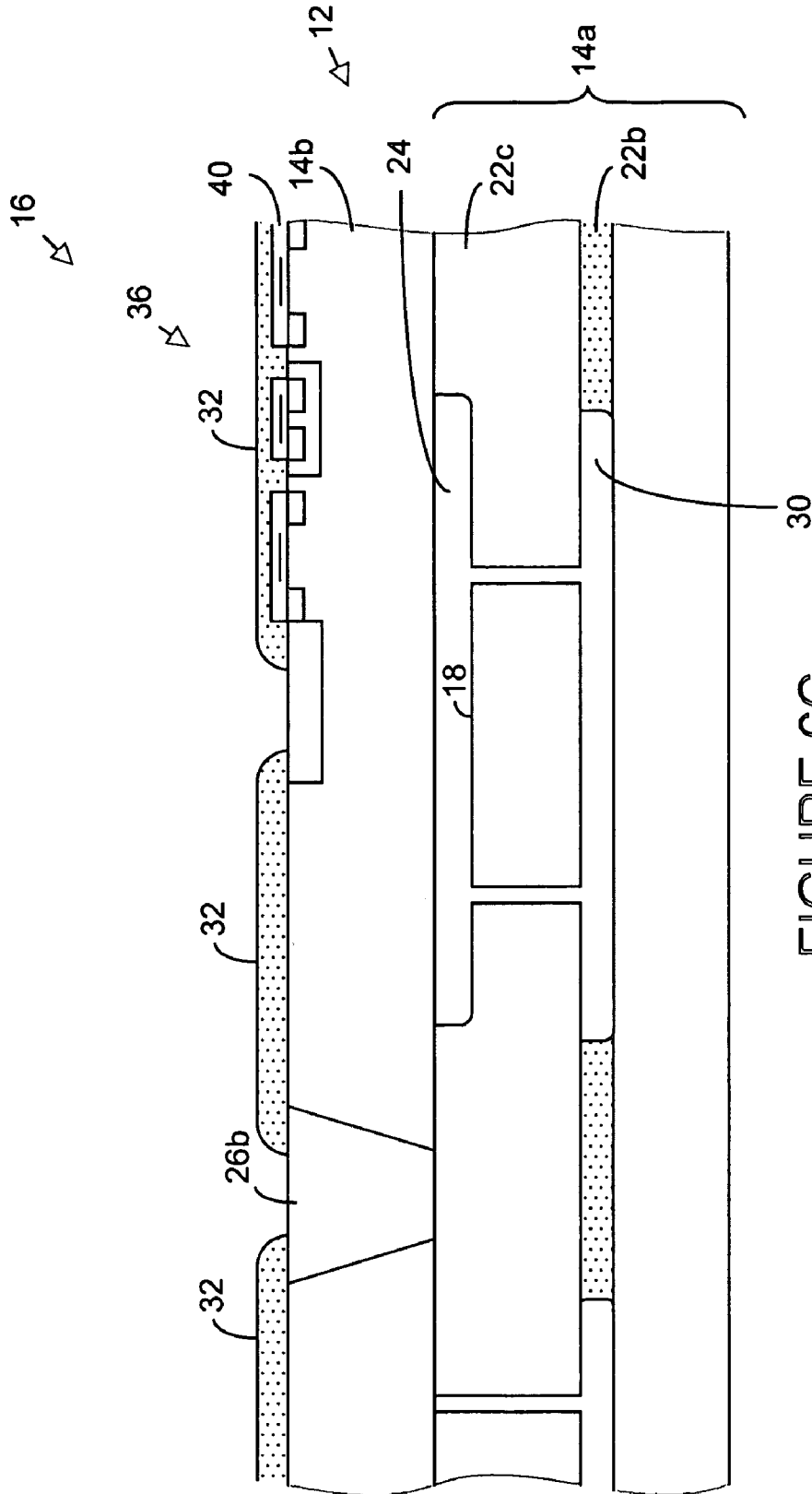

FIGURE 6C

10

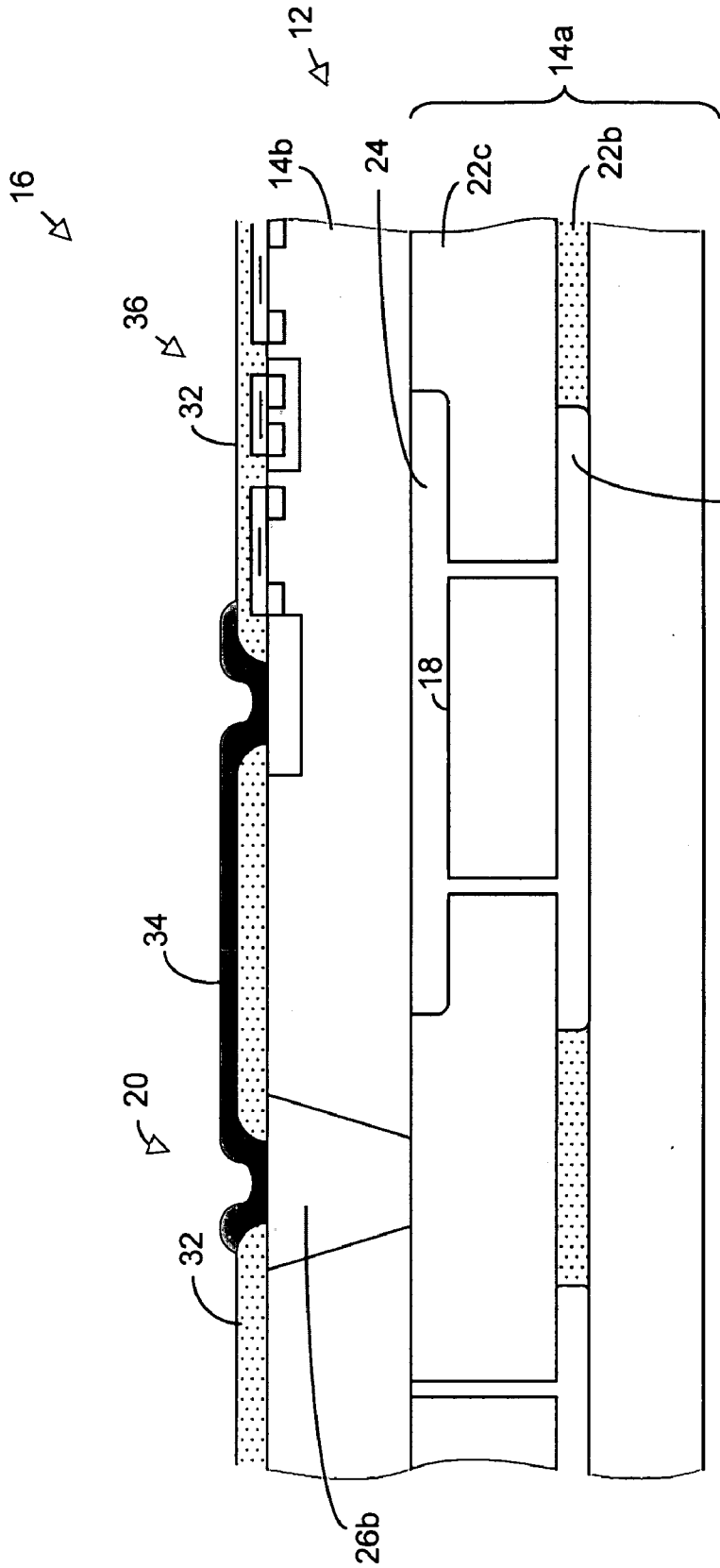

FIGURE 6D

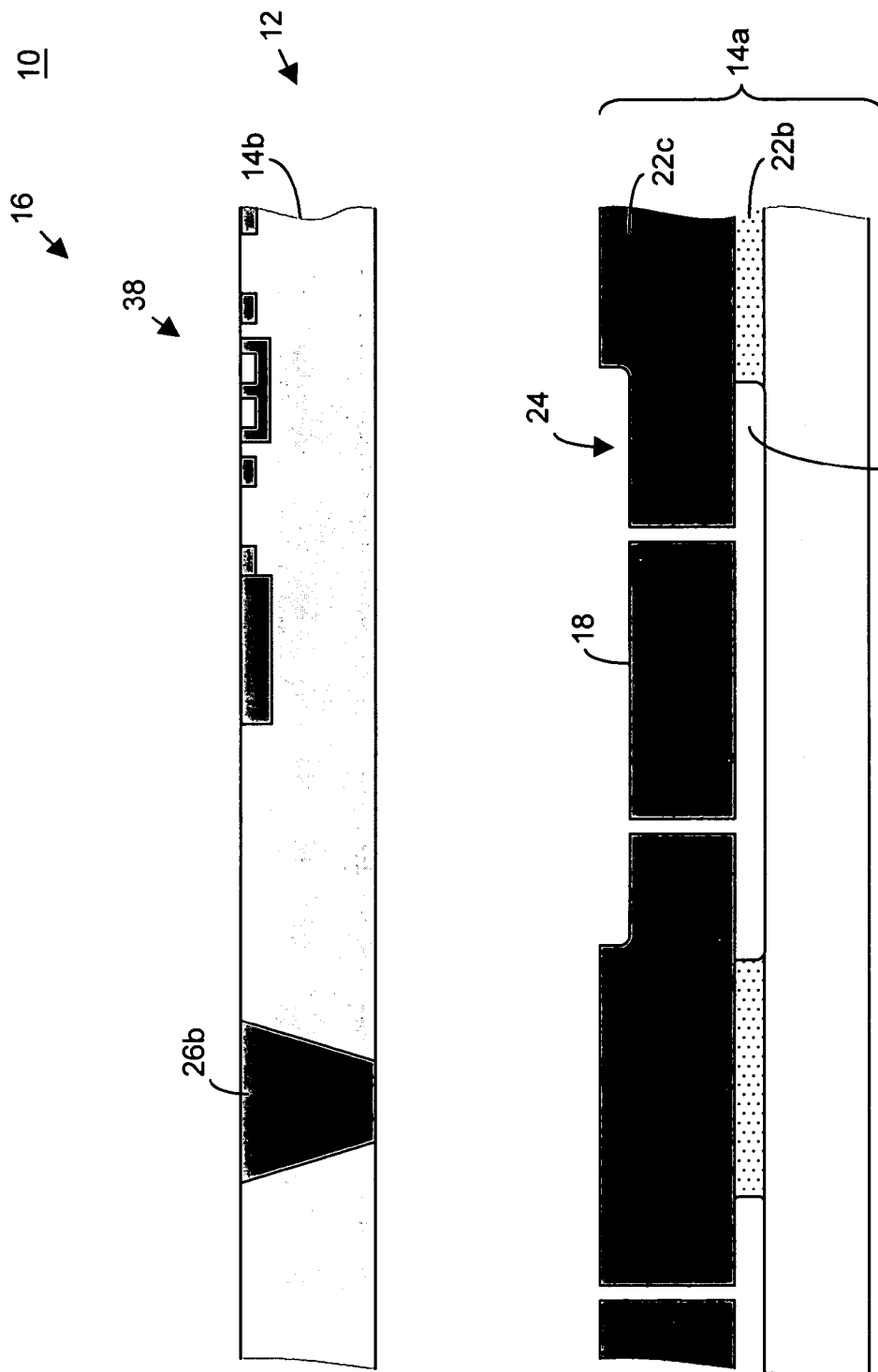

FIGURE 7A

10

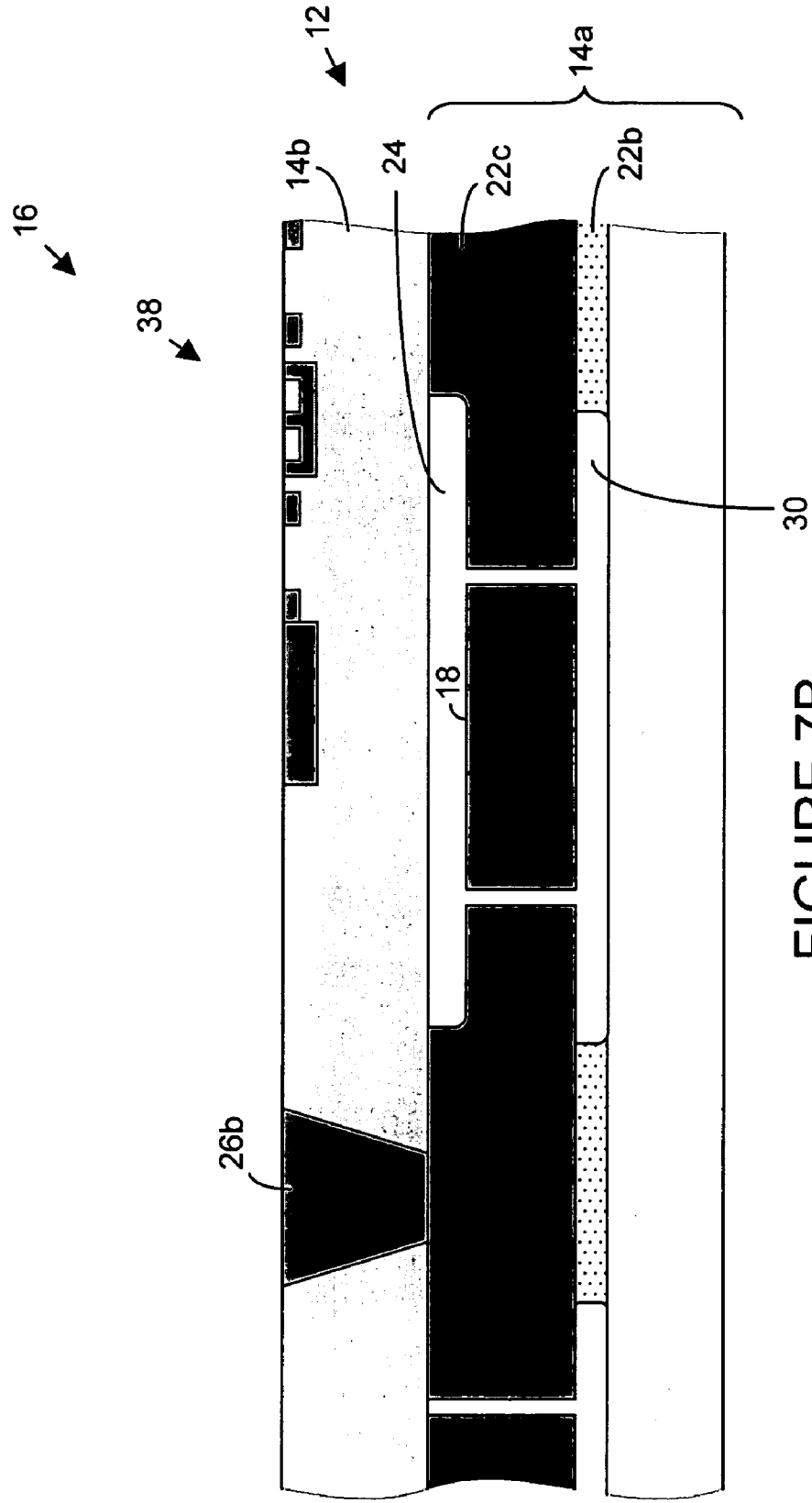

FIGURE 7B

10

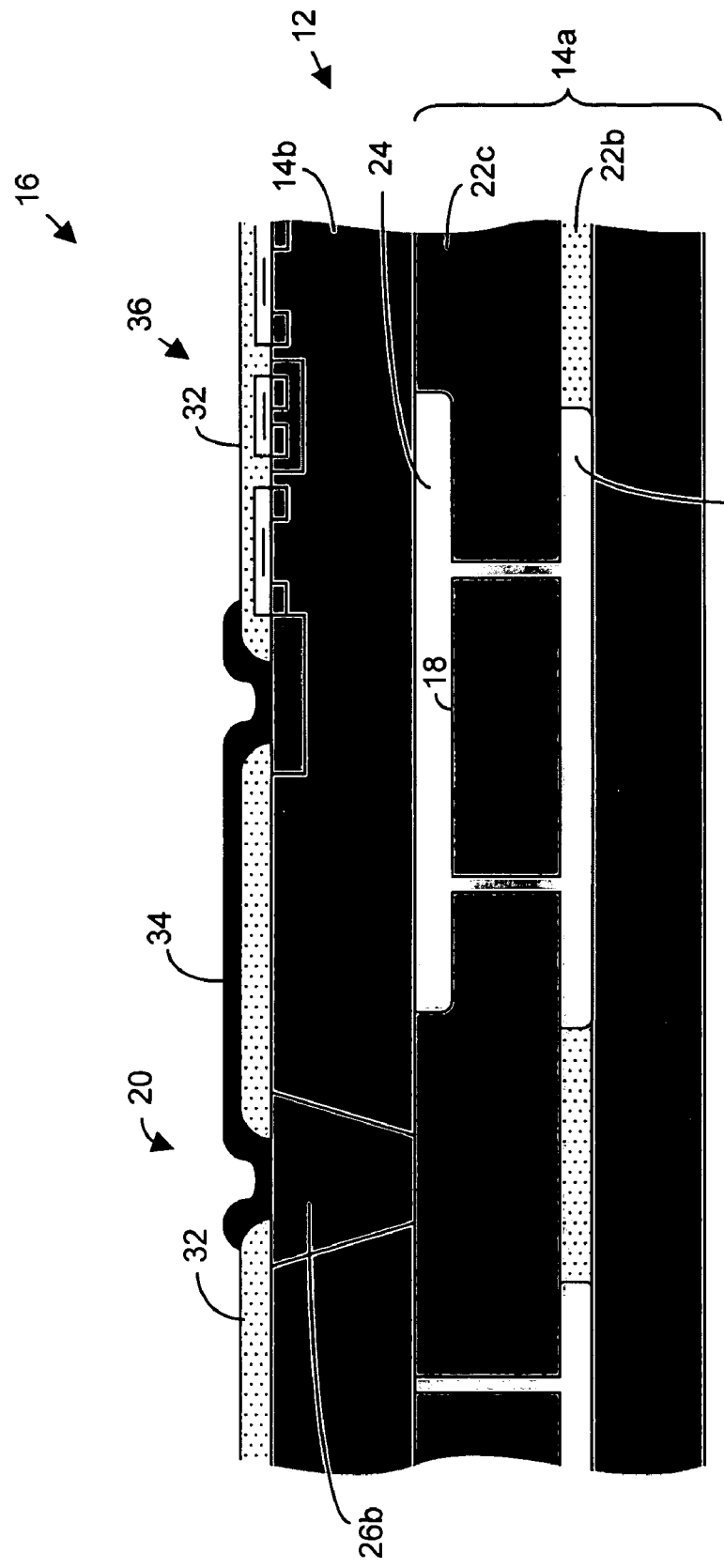

FIGURE 7C

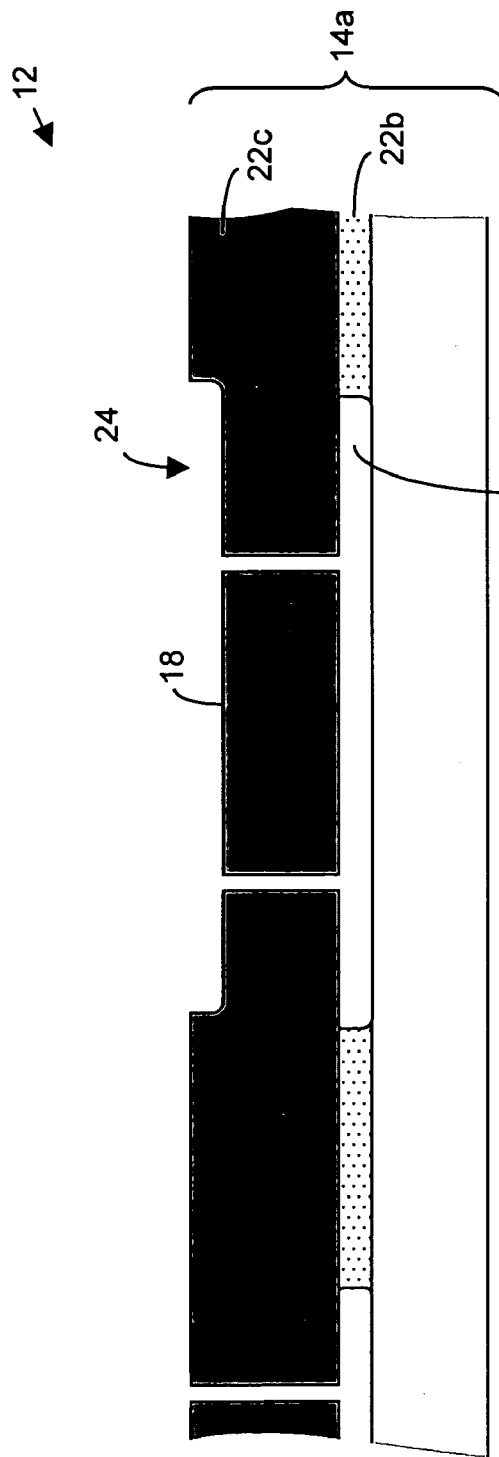
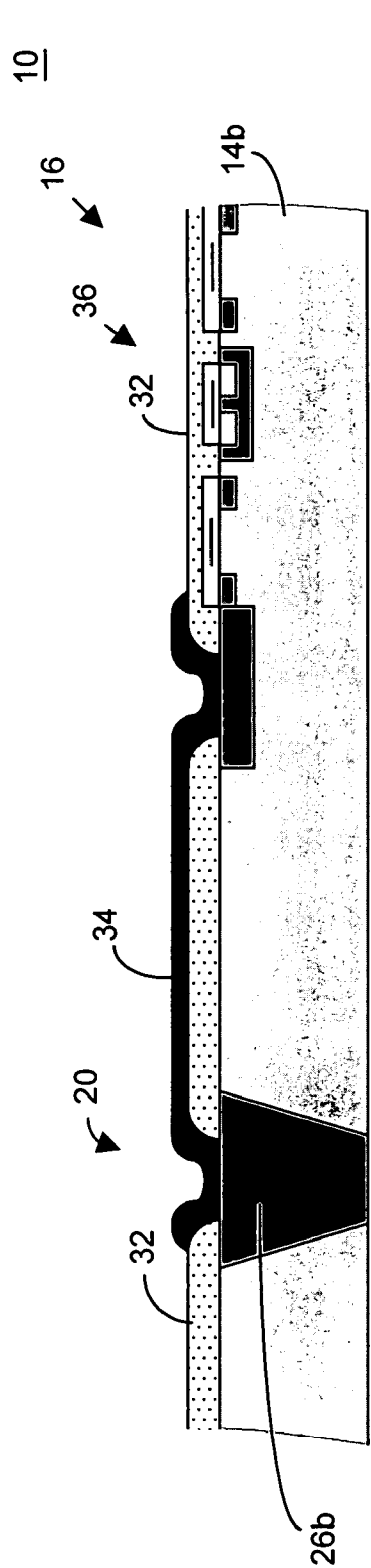

FIGURE 8A

10

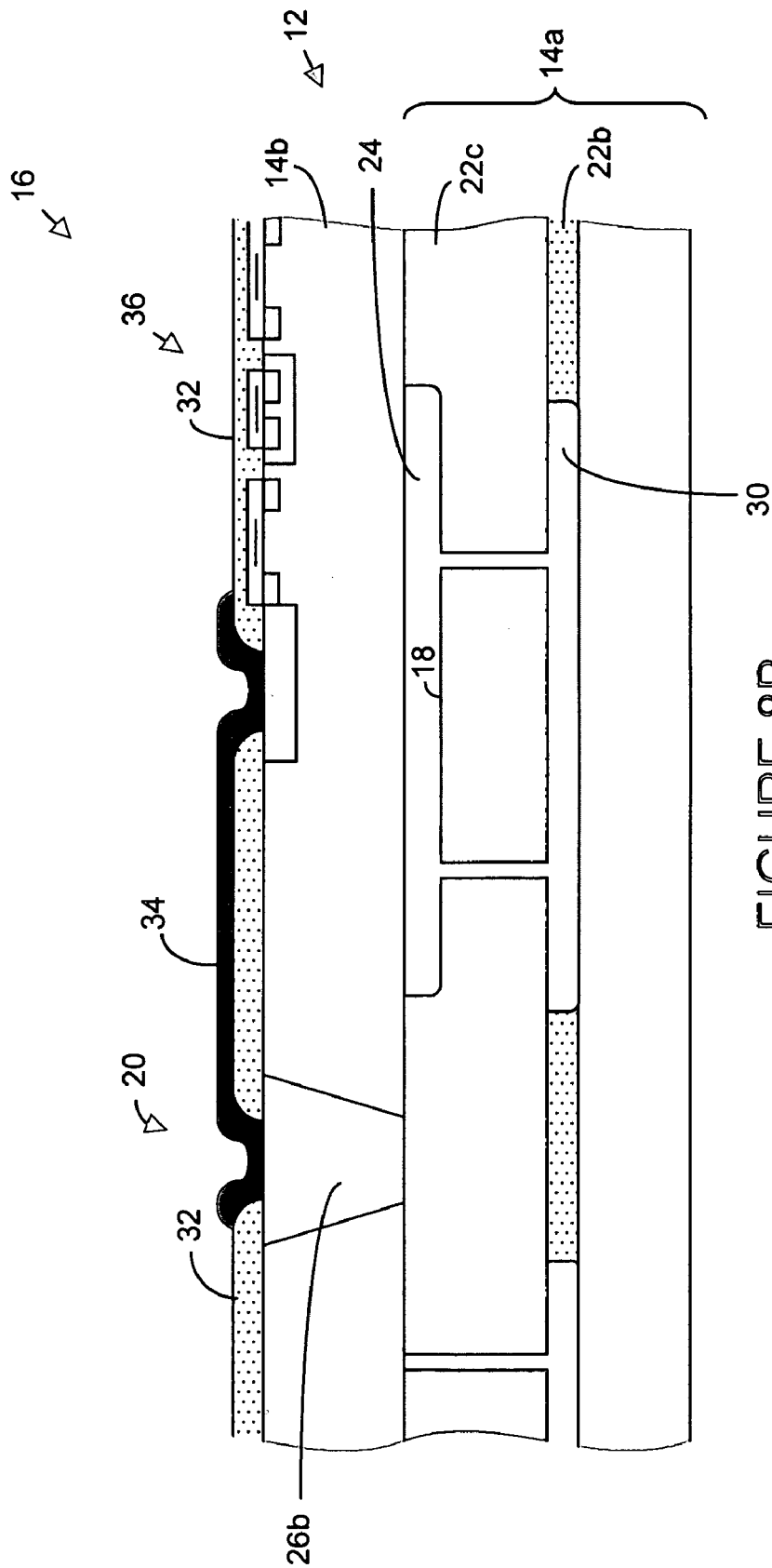

FIGURE 8B

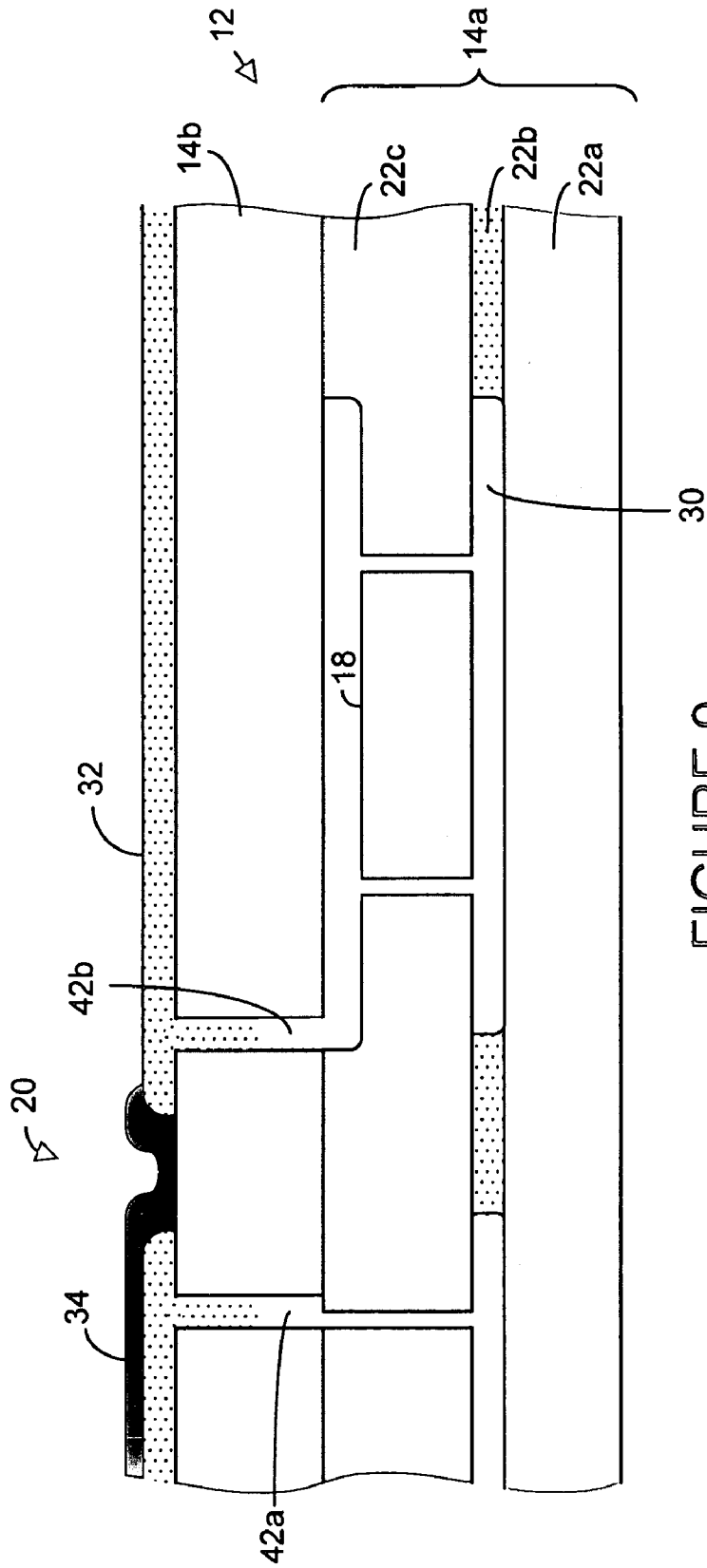

FIGURE 9

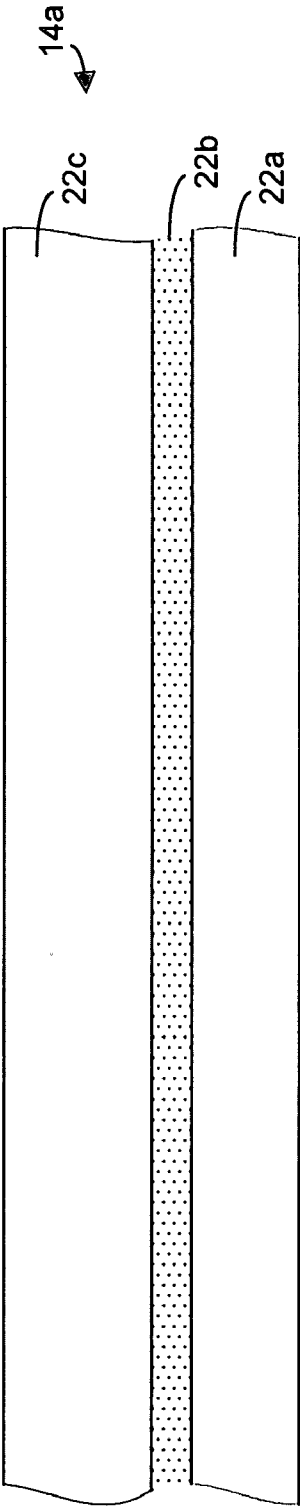

FIGURE 10A

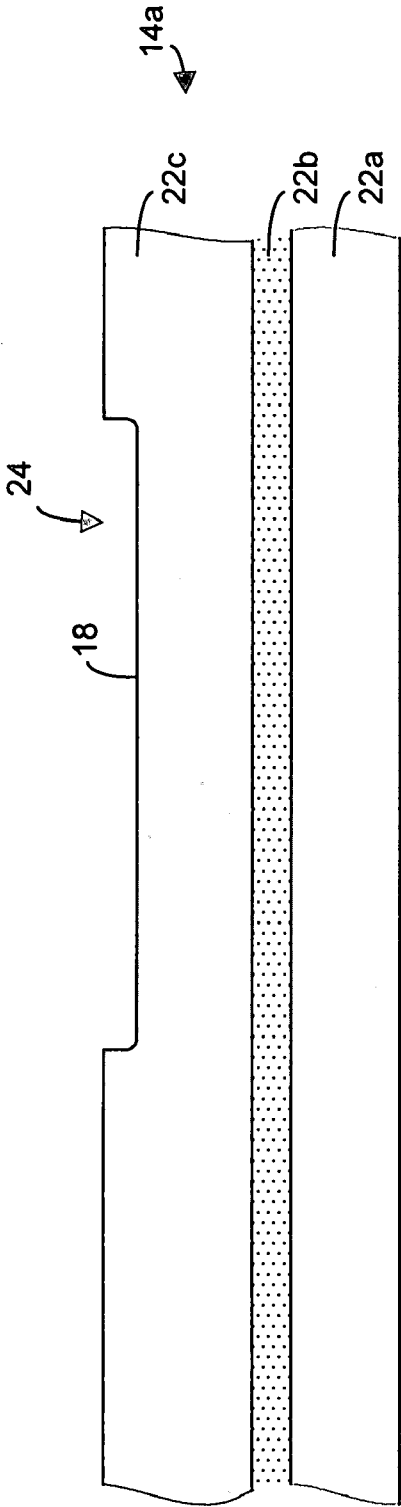

FIGURE 10B

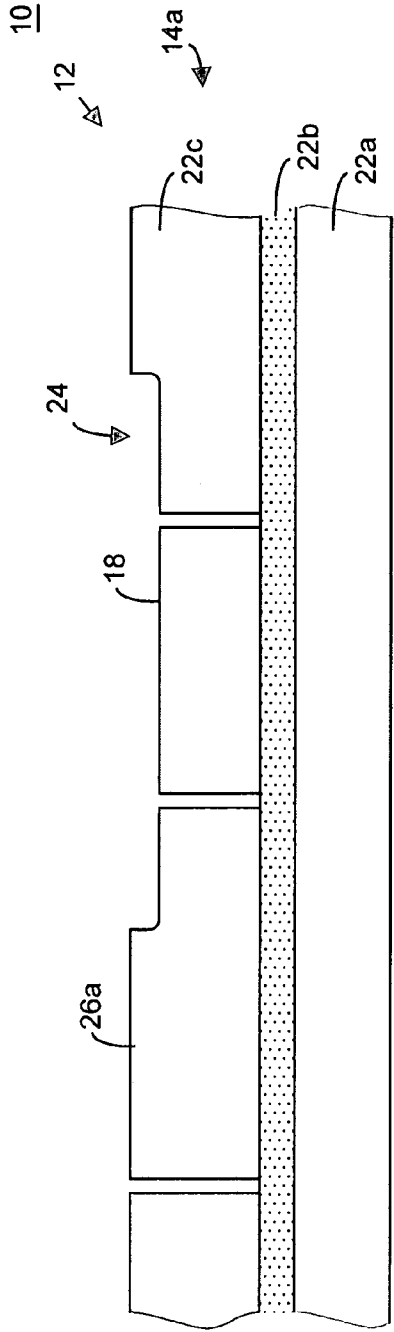

FIGURE 10C

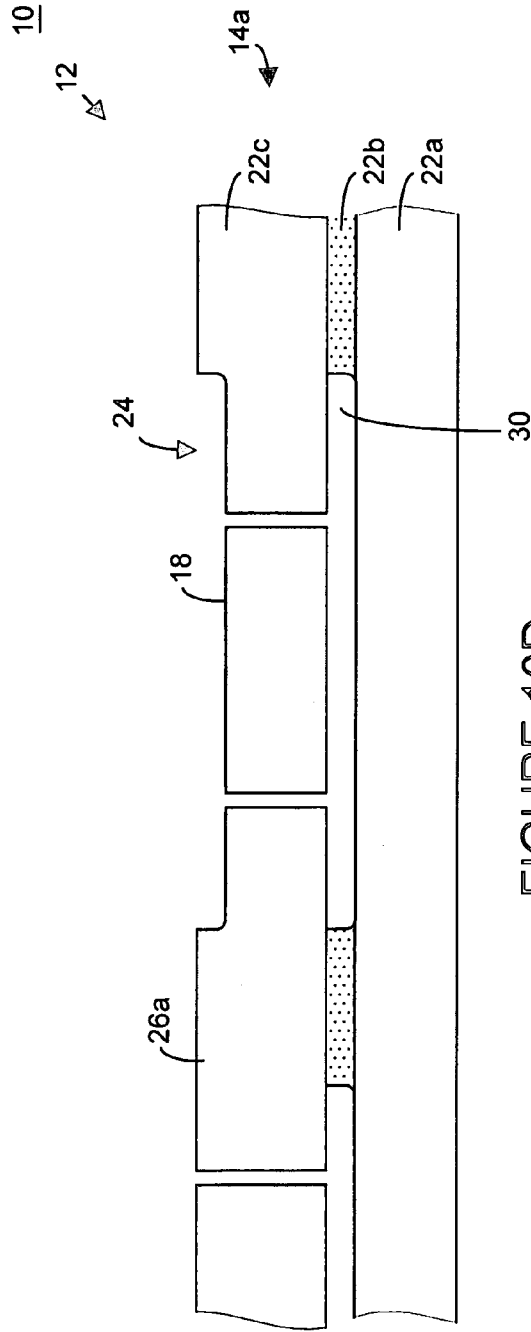

FIGURE 10D

10

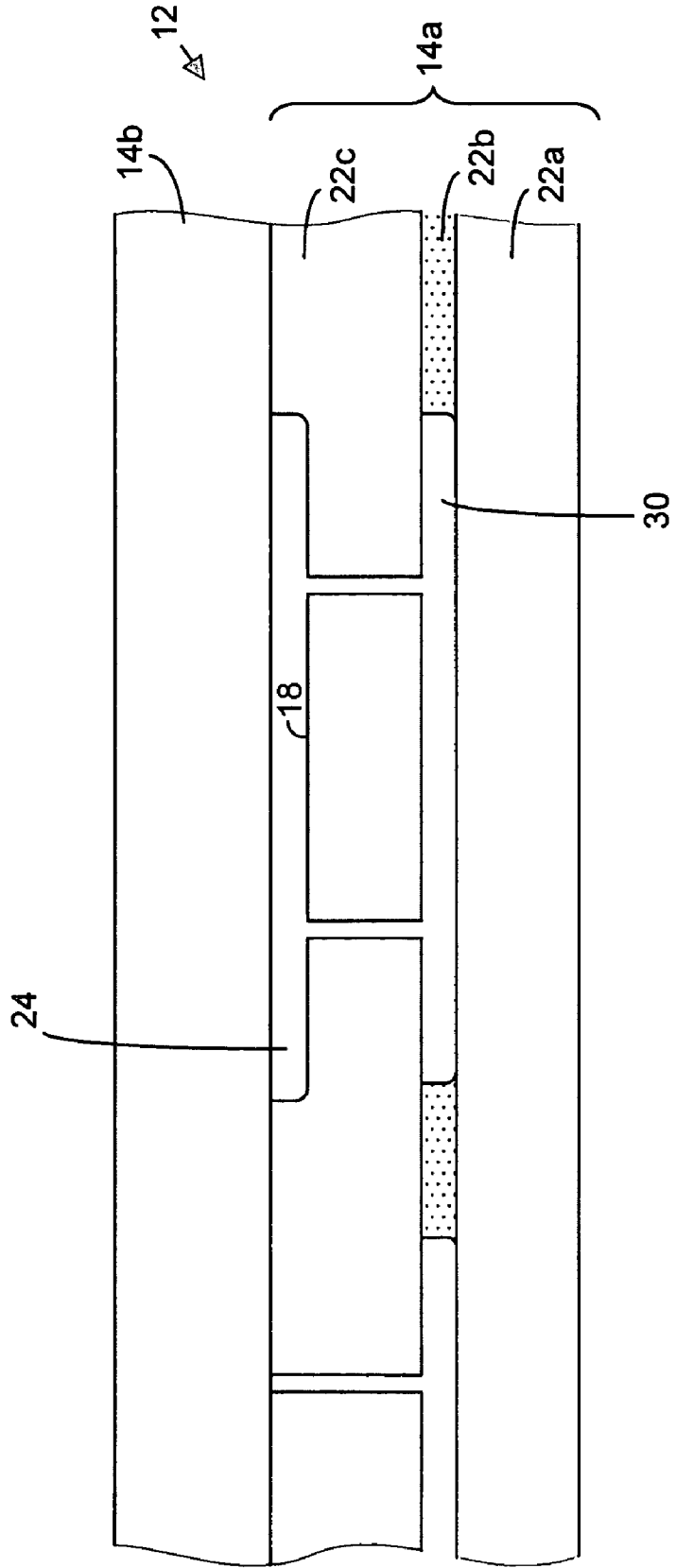

FIGURE 10E

10

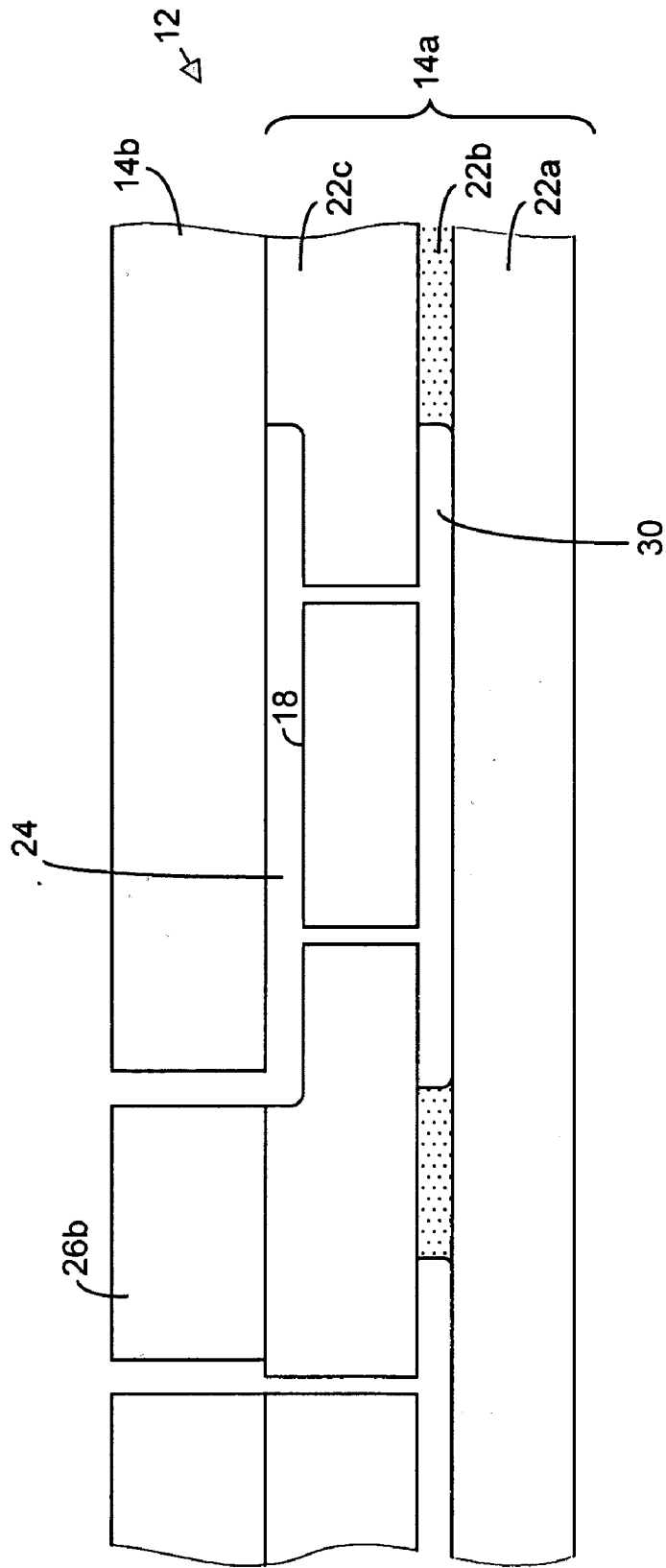

FIGURE 10F

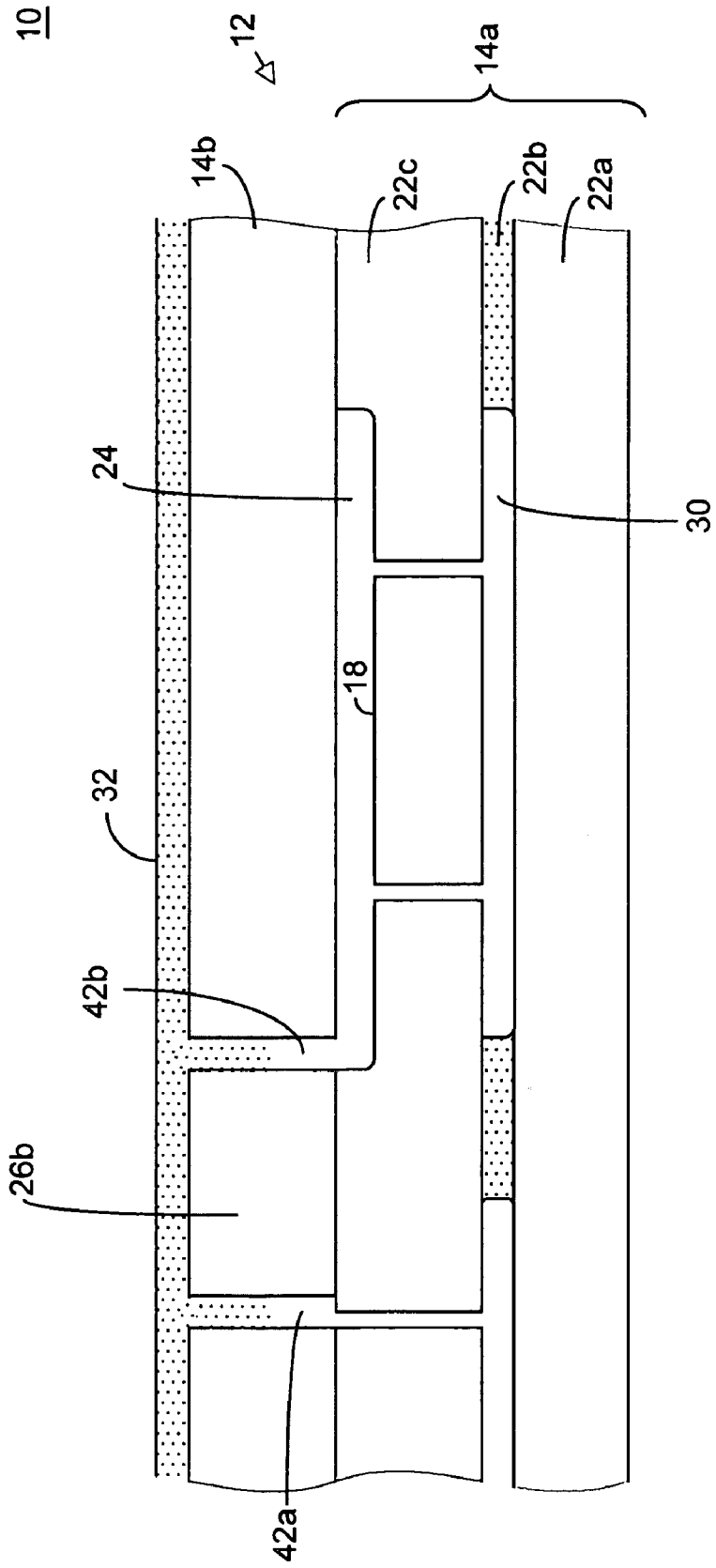

FIGURE 10G

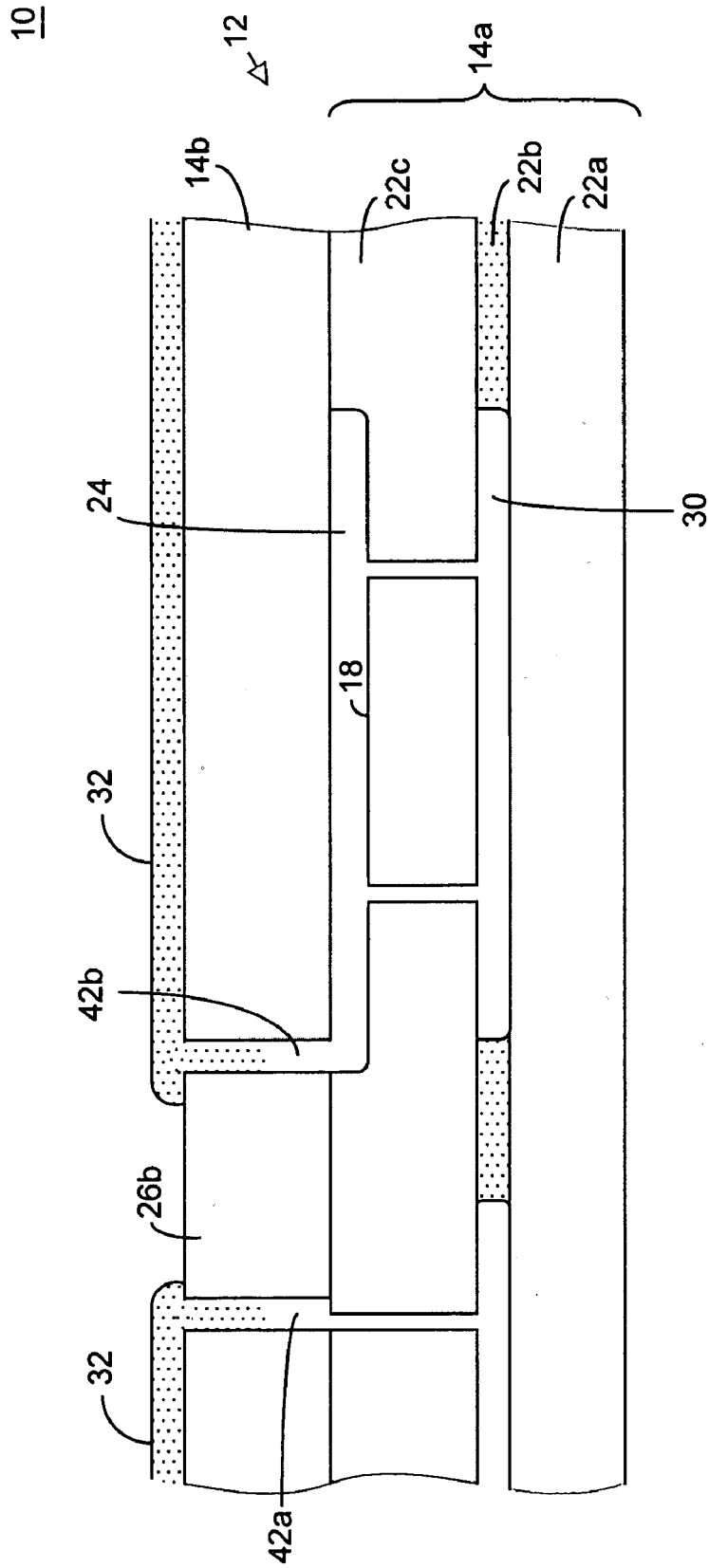

FIGURE 10H

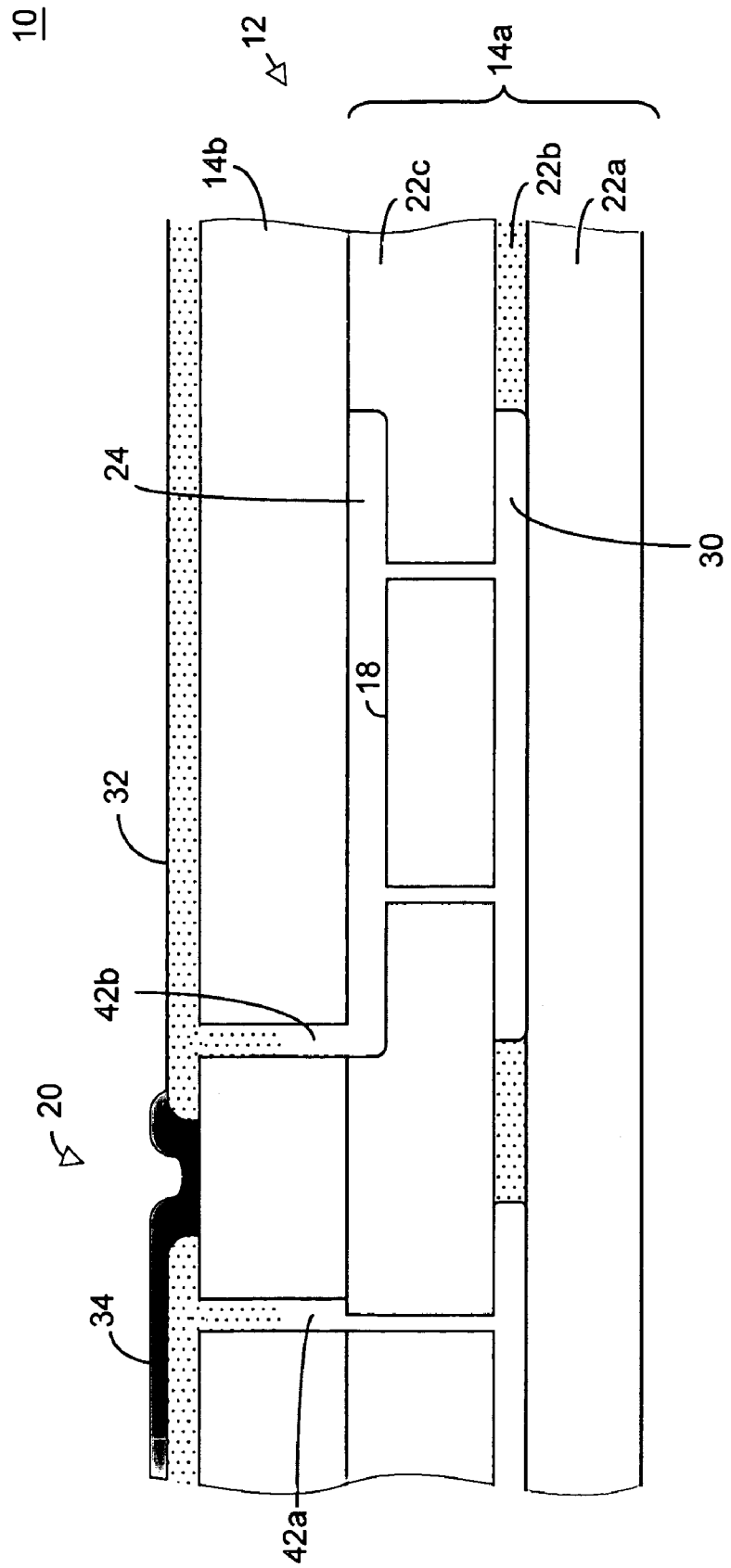

FIGURE 10I

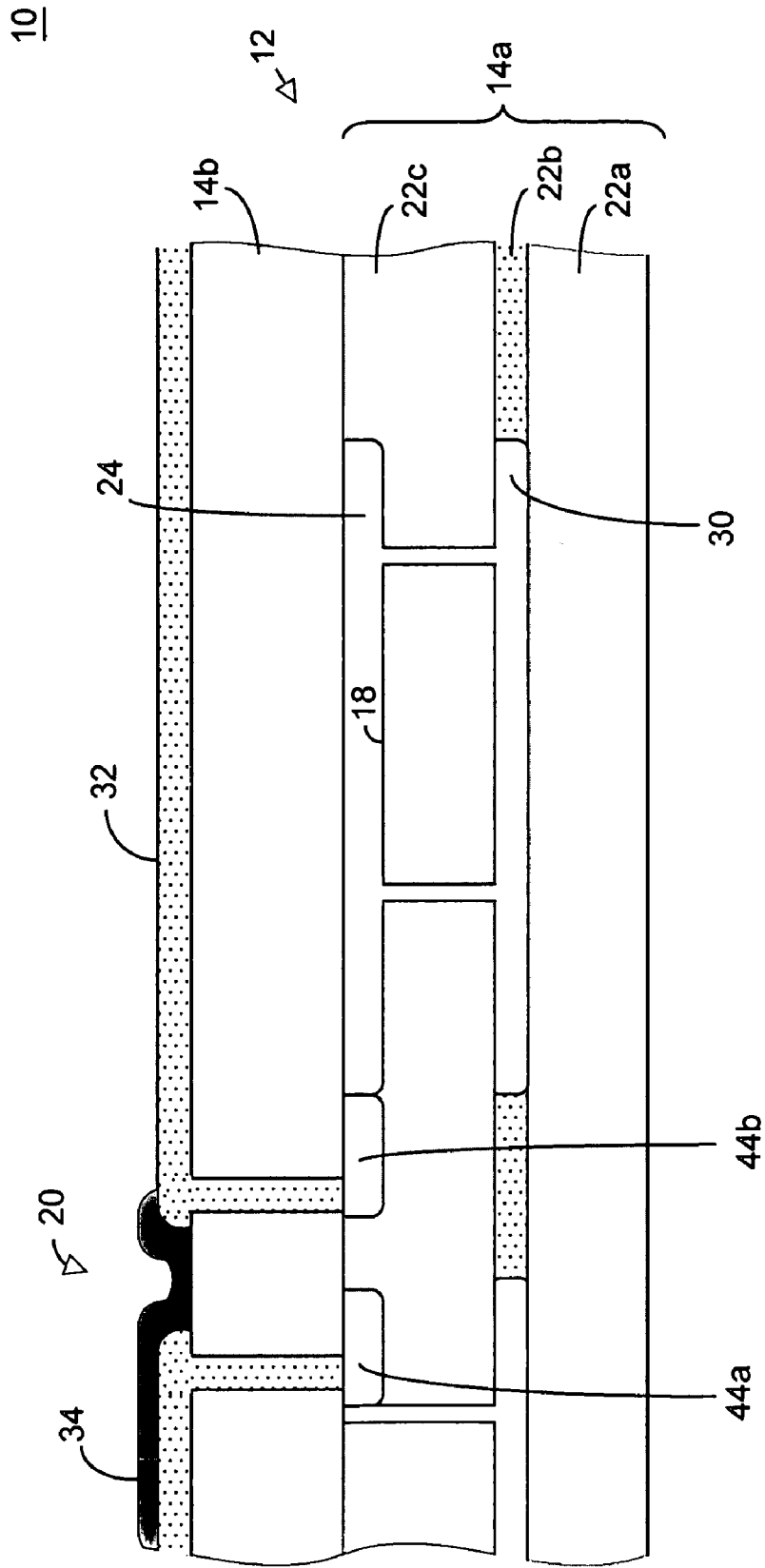

FIGURE 11

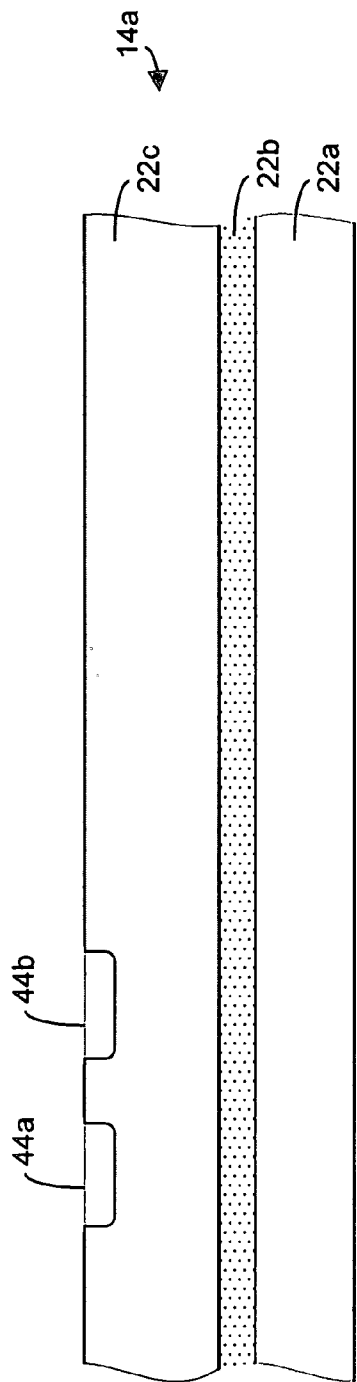

FIGURE 12A

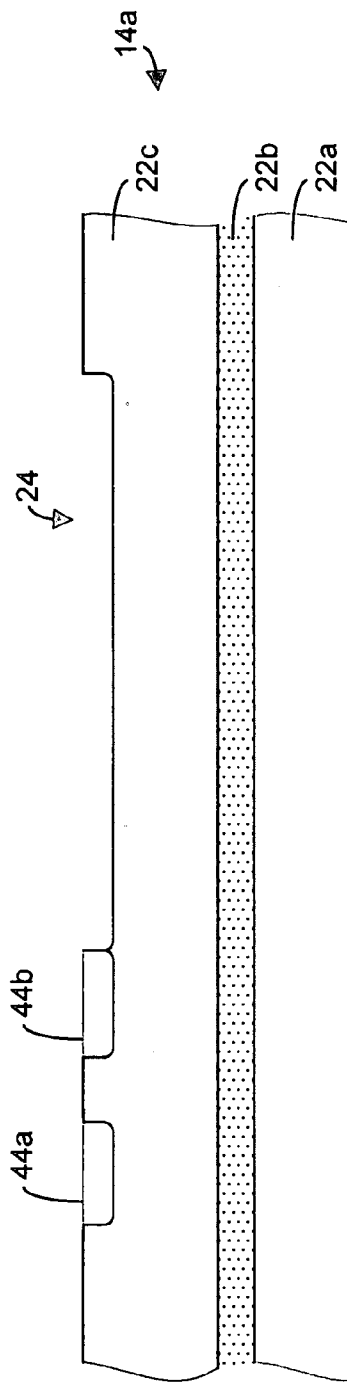

FIGURE 12B

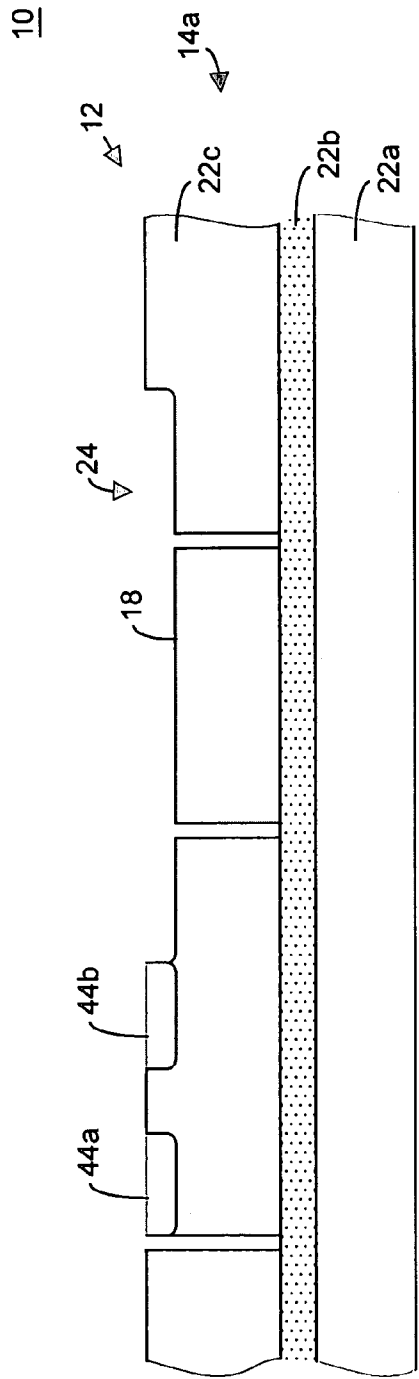

FIGURE 12C

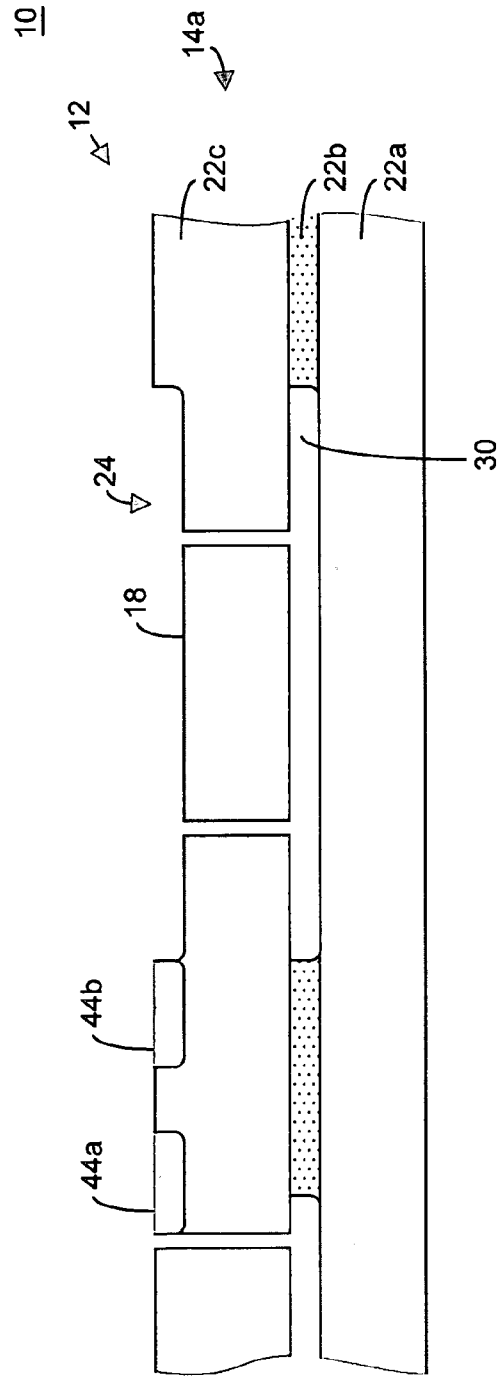

FIGURE 12D

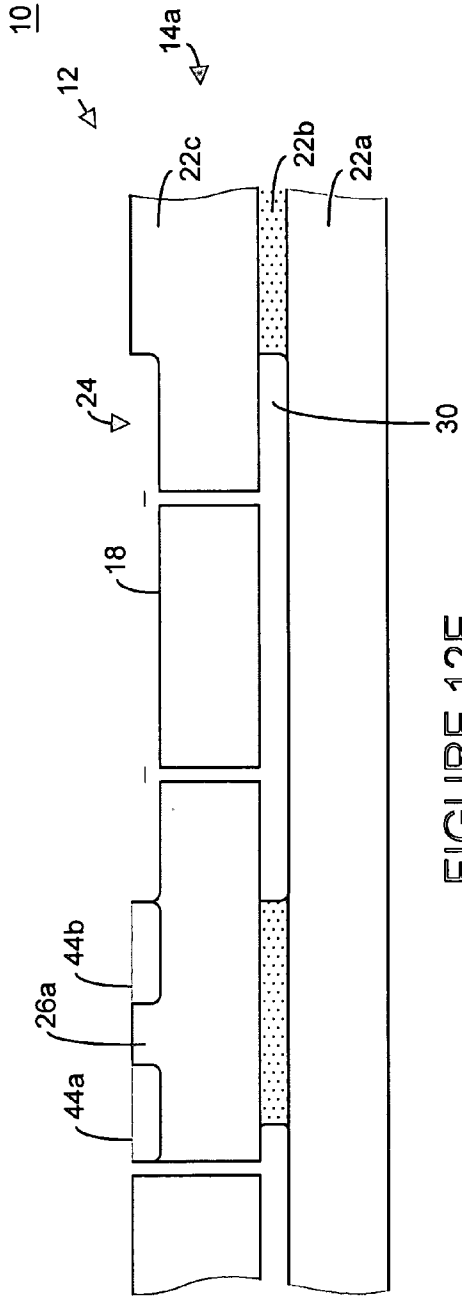

FIGURE 12E

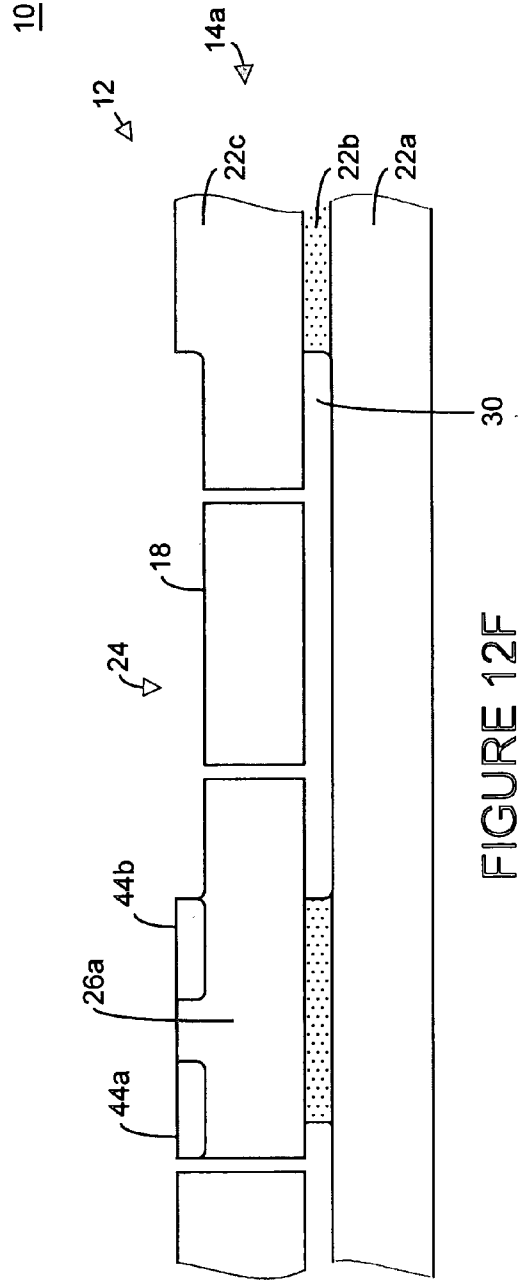

FIGURE 12F

10

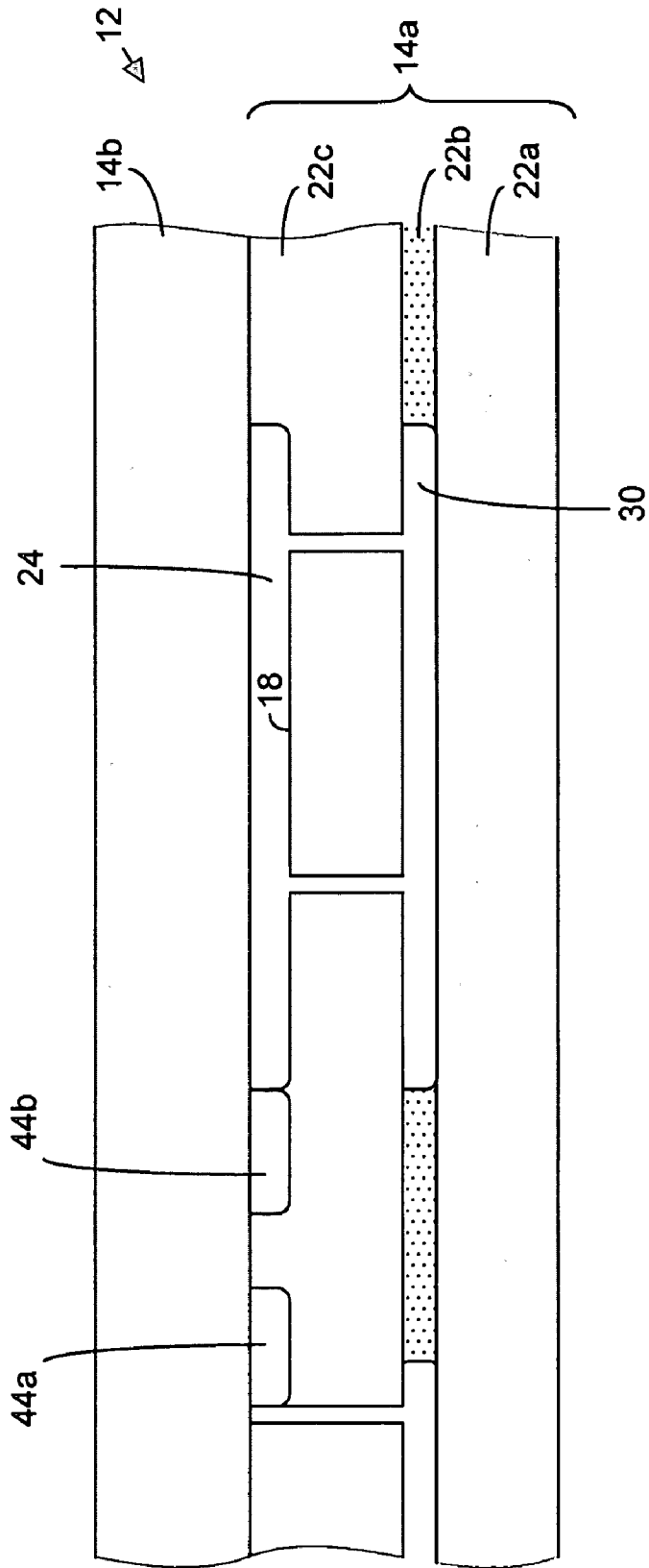

FIGURE 12G

10

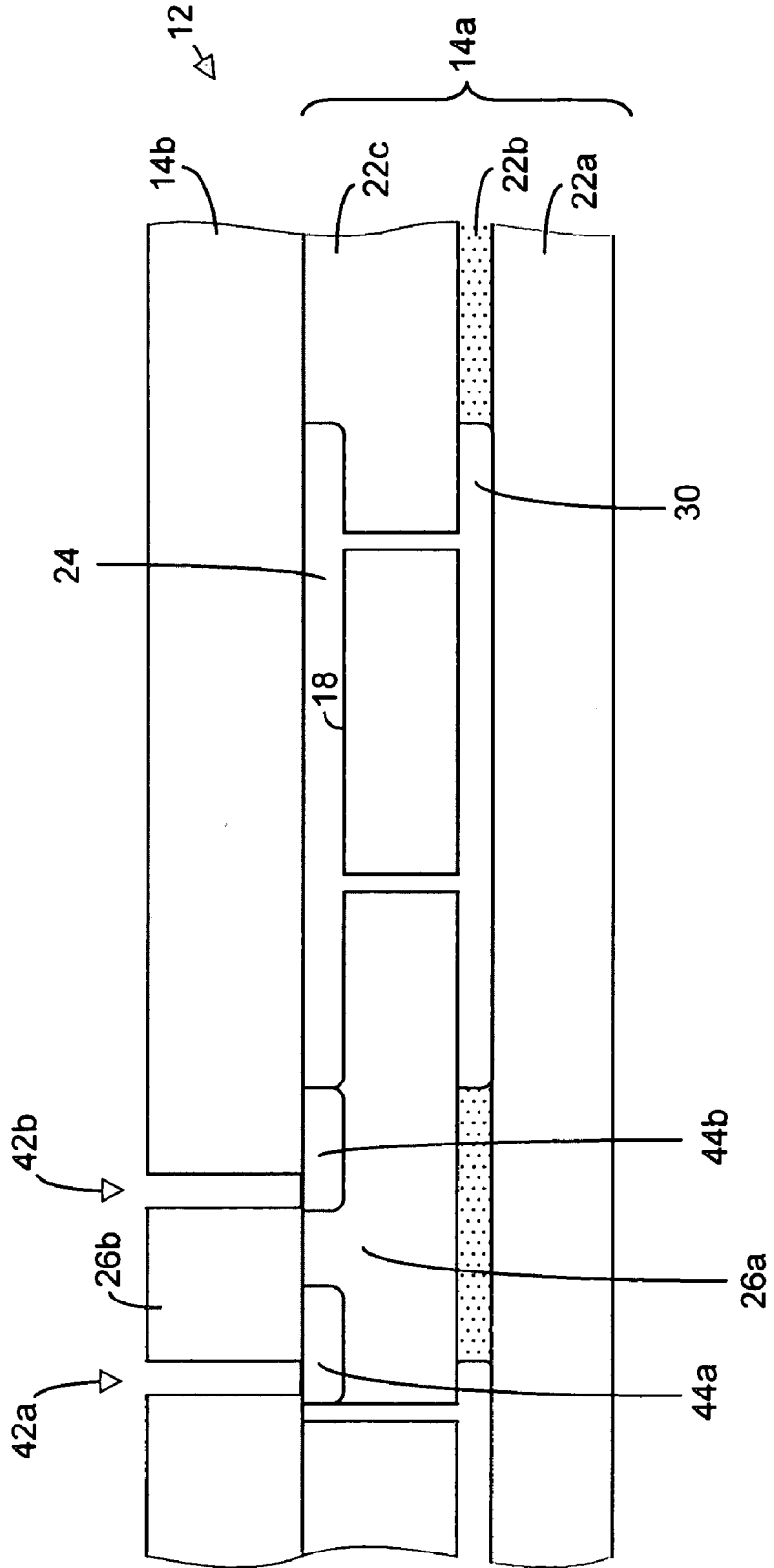

FIGURE 12H

10

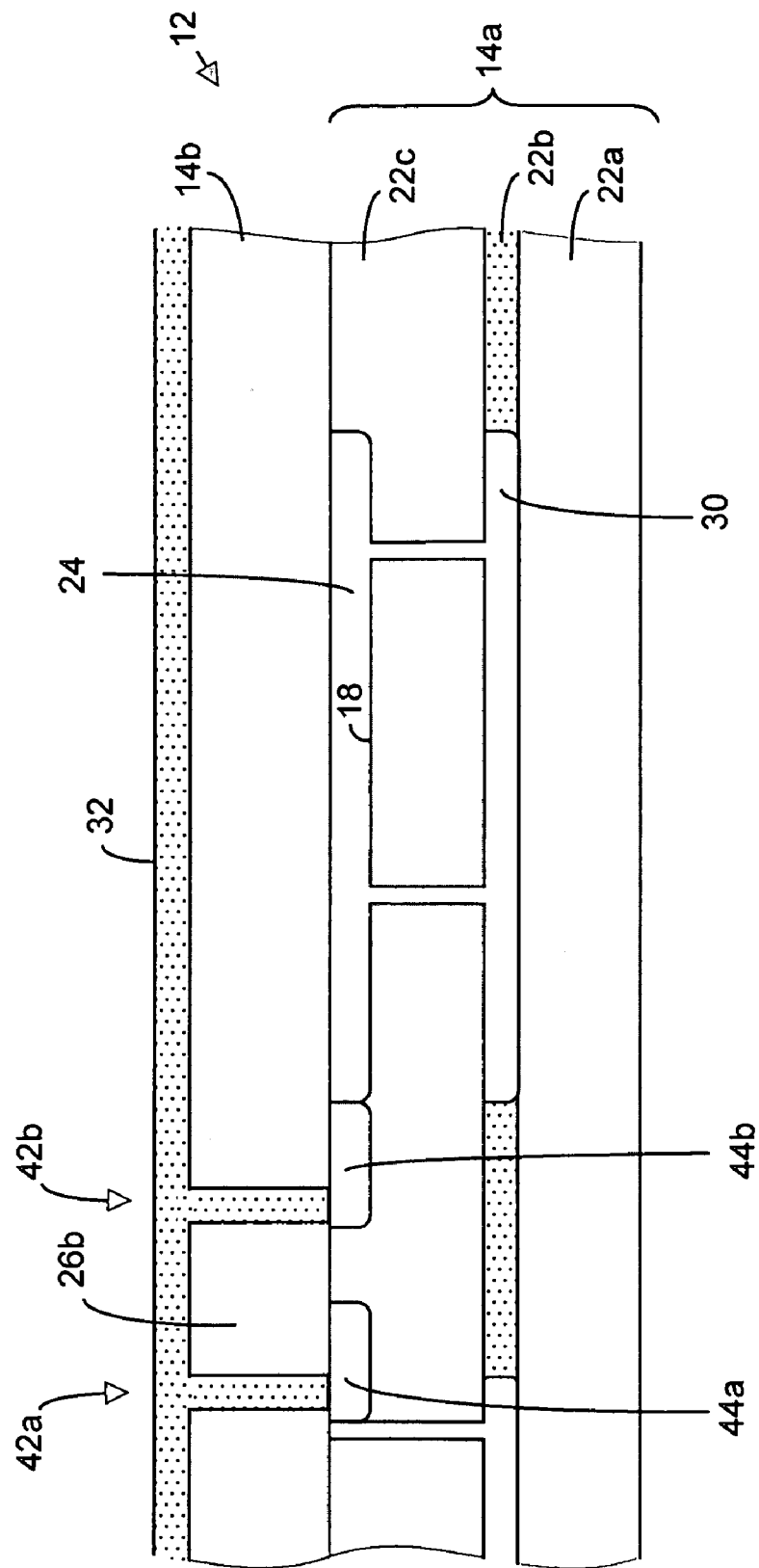

FIGURE 12I

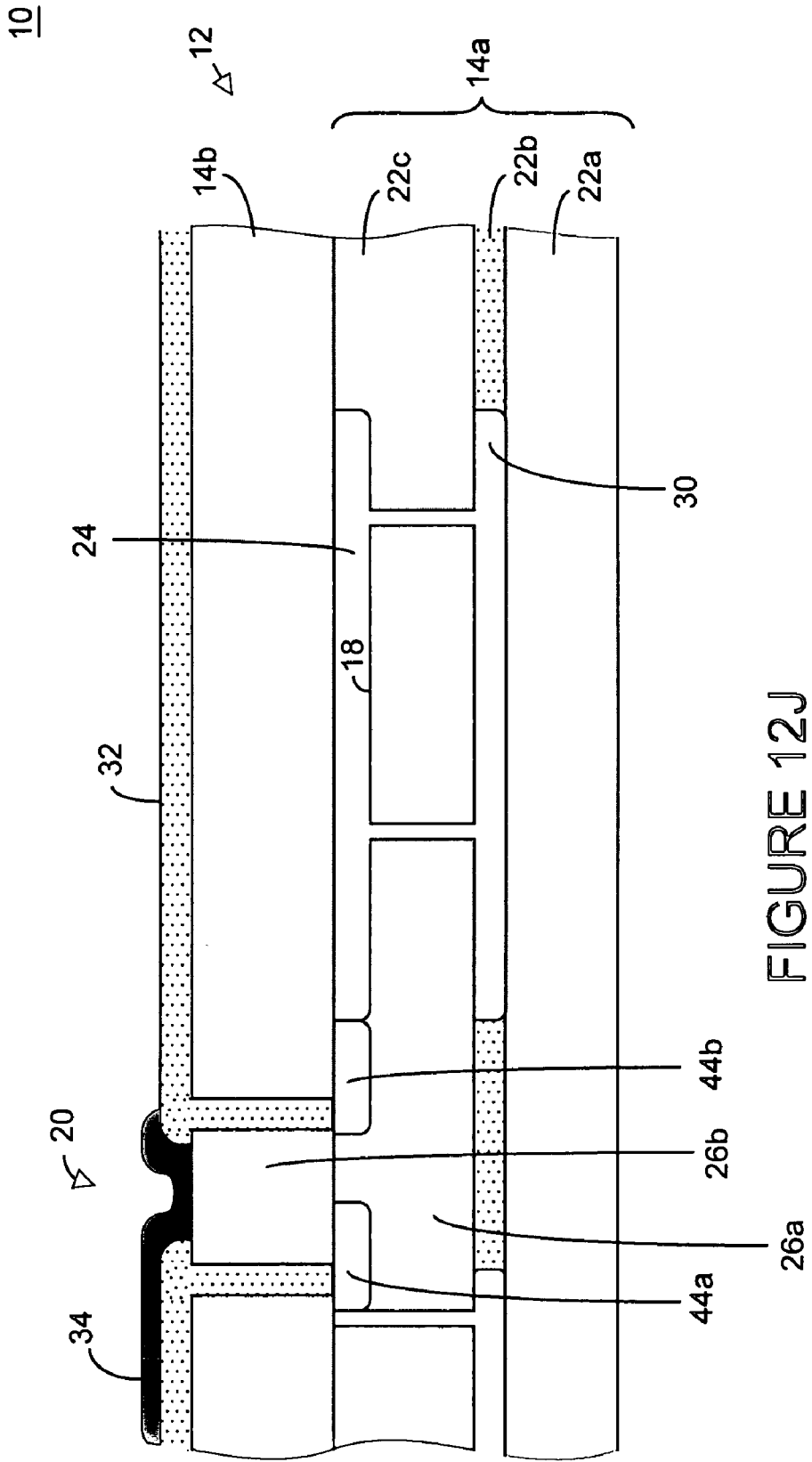
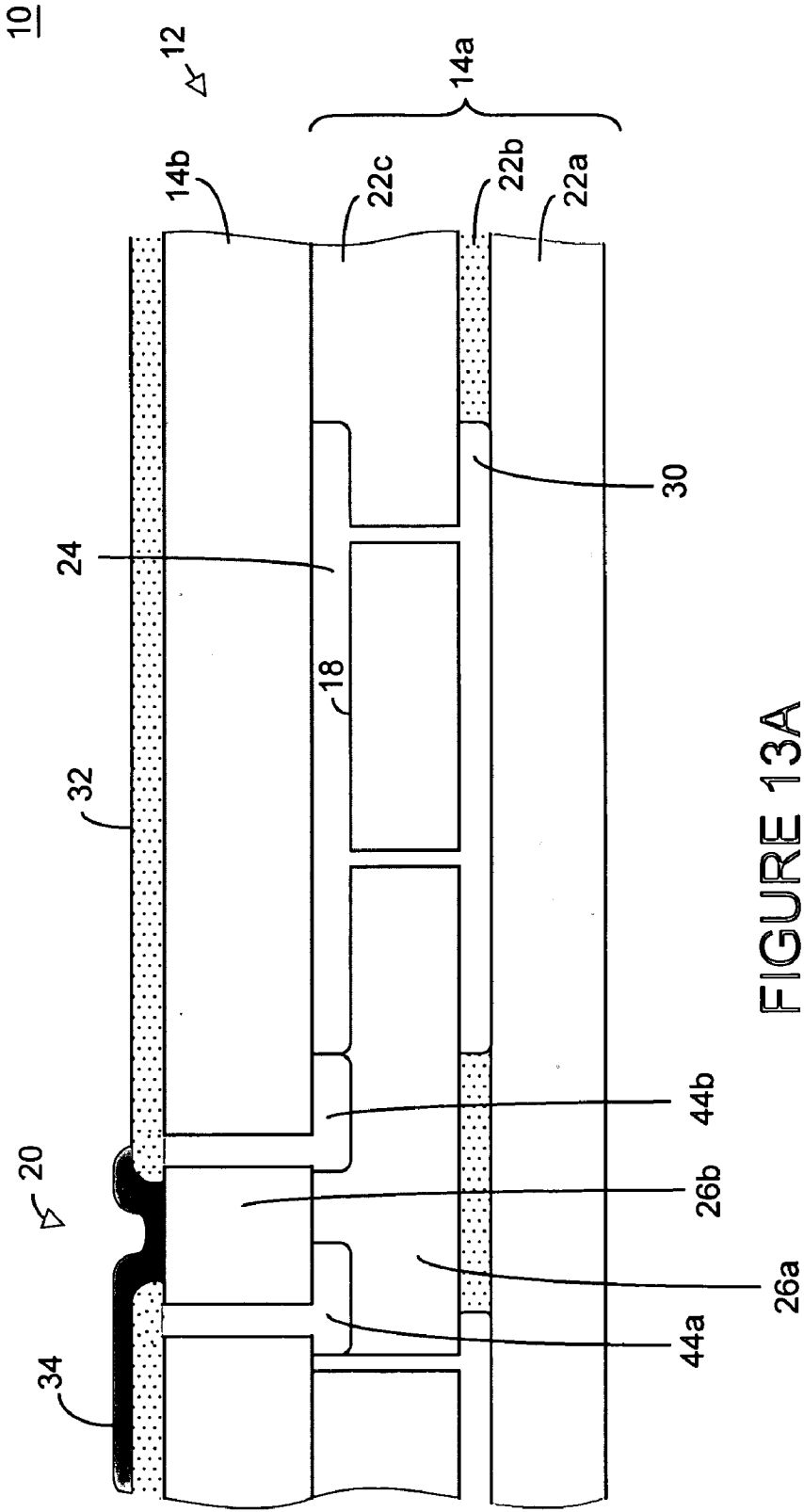

FIGURE 12J



10

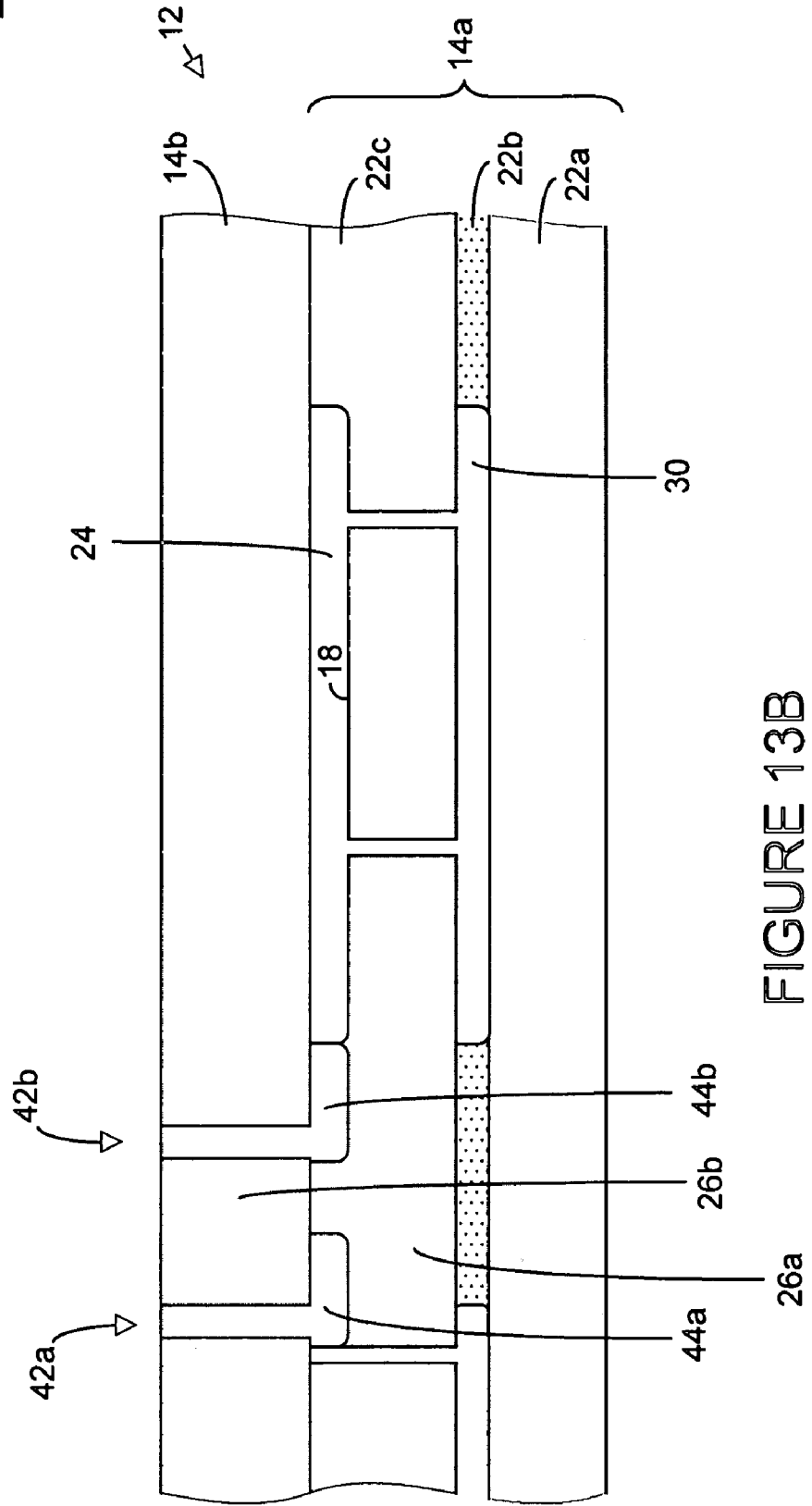

FIGURE 13B

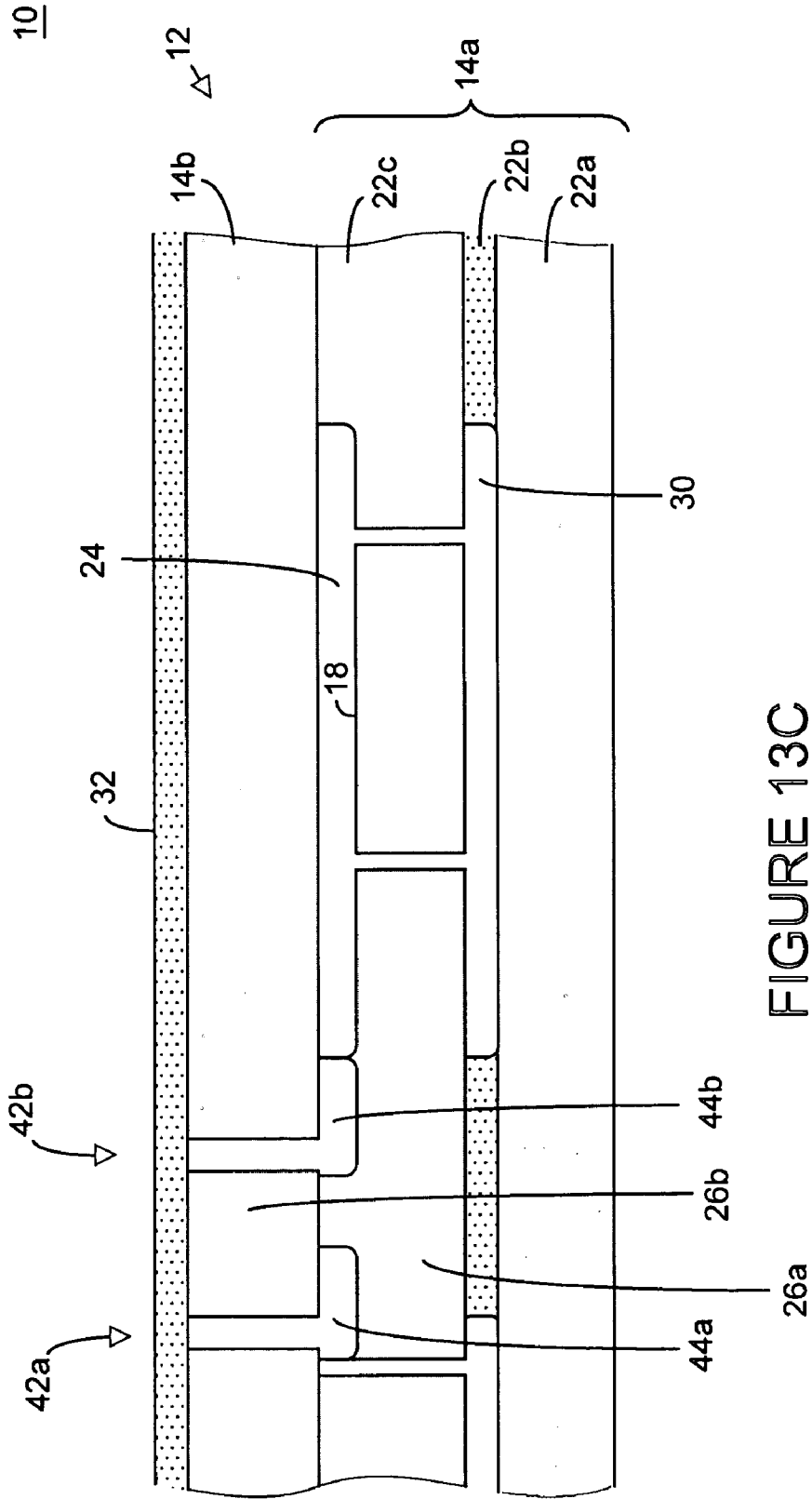

FIGURE 13C

10

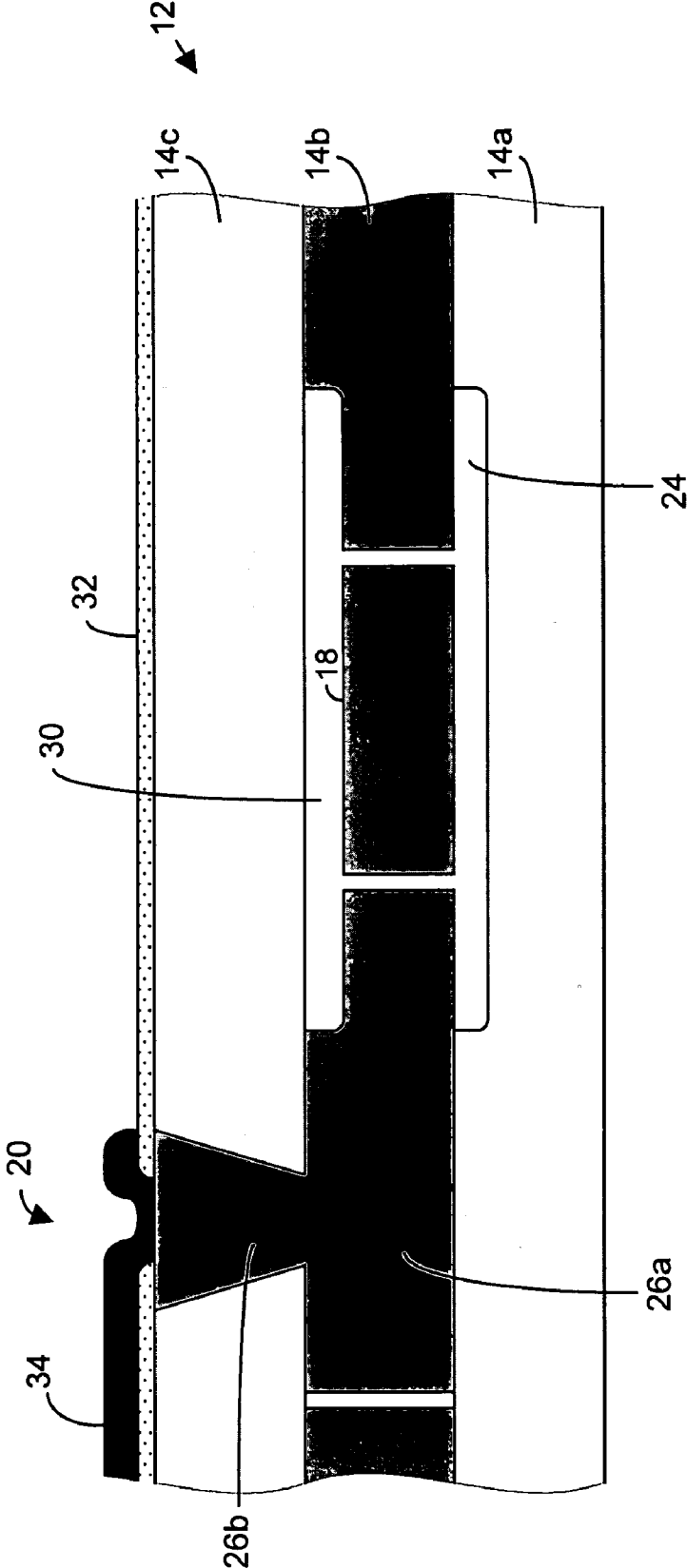

FIGURE 14

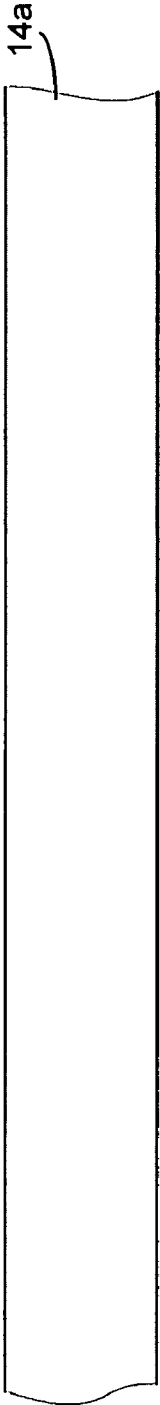

FIGURE 15A

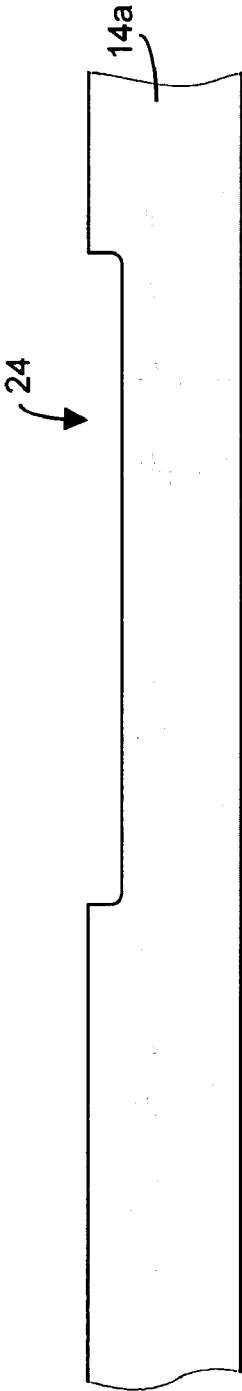

FIGURE 15B

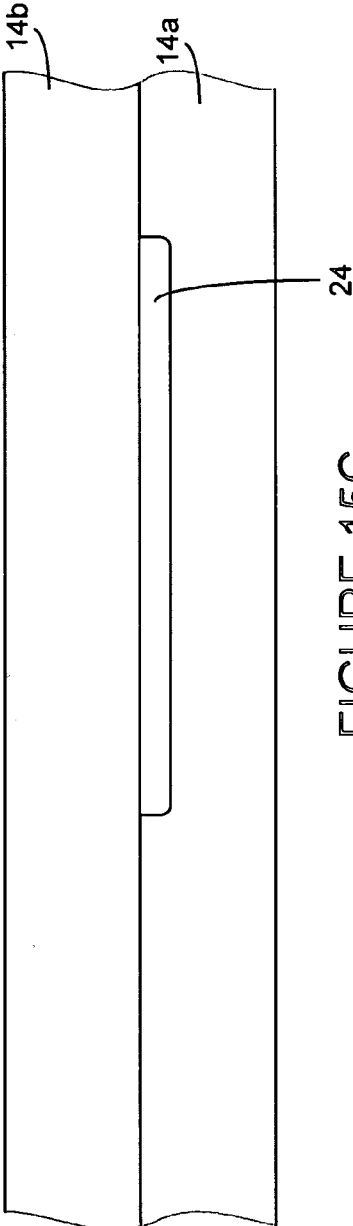

FIGURE 15C

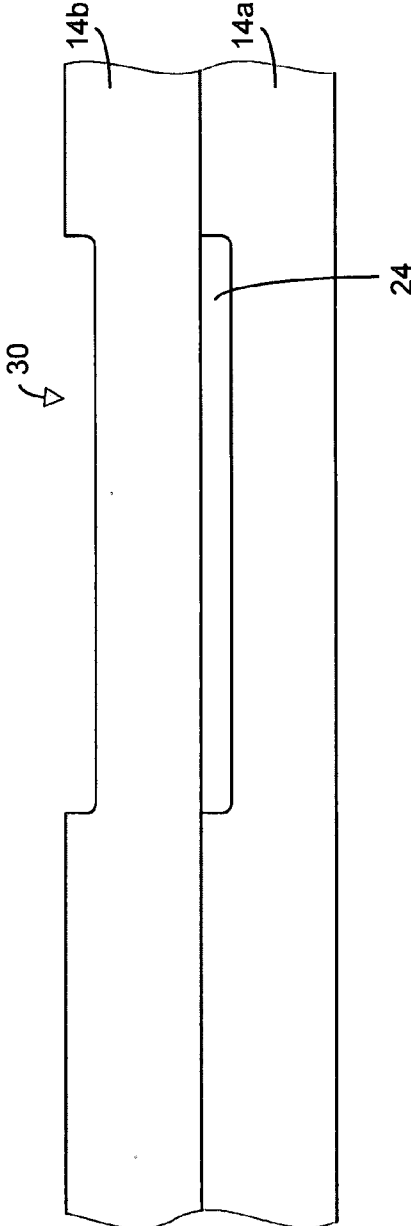

FIGURE 15D

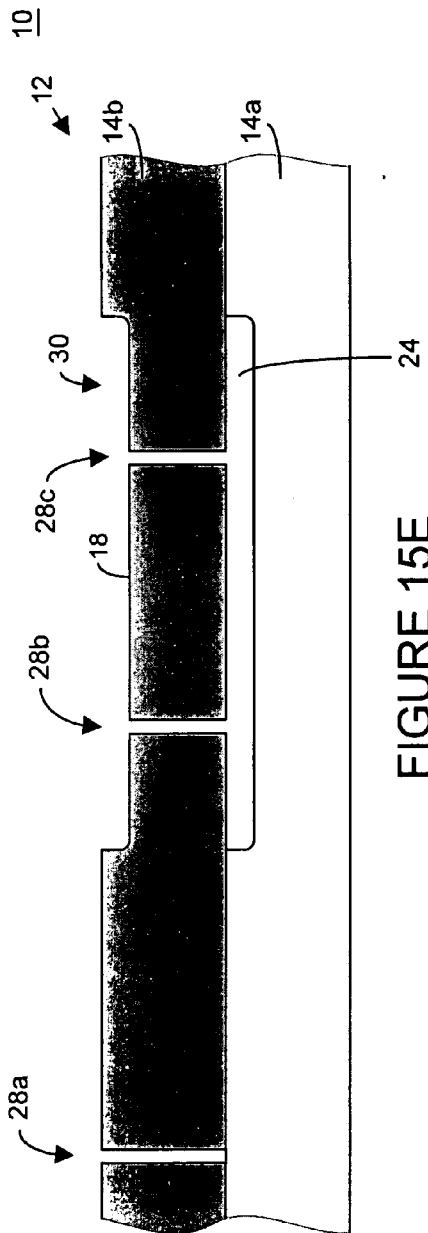

FIGURE 15E

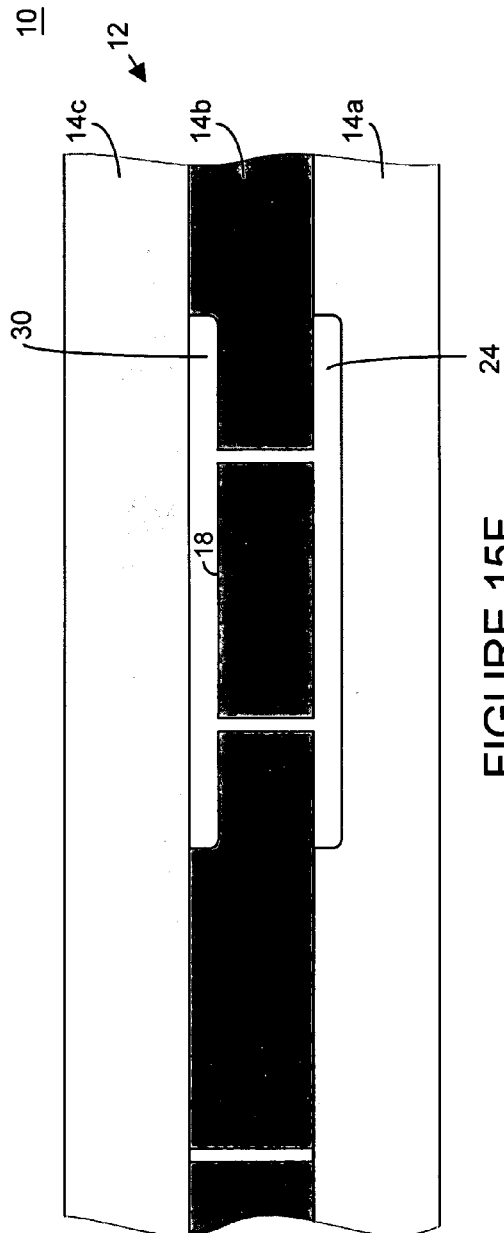

FIGURE 15F

10

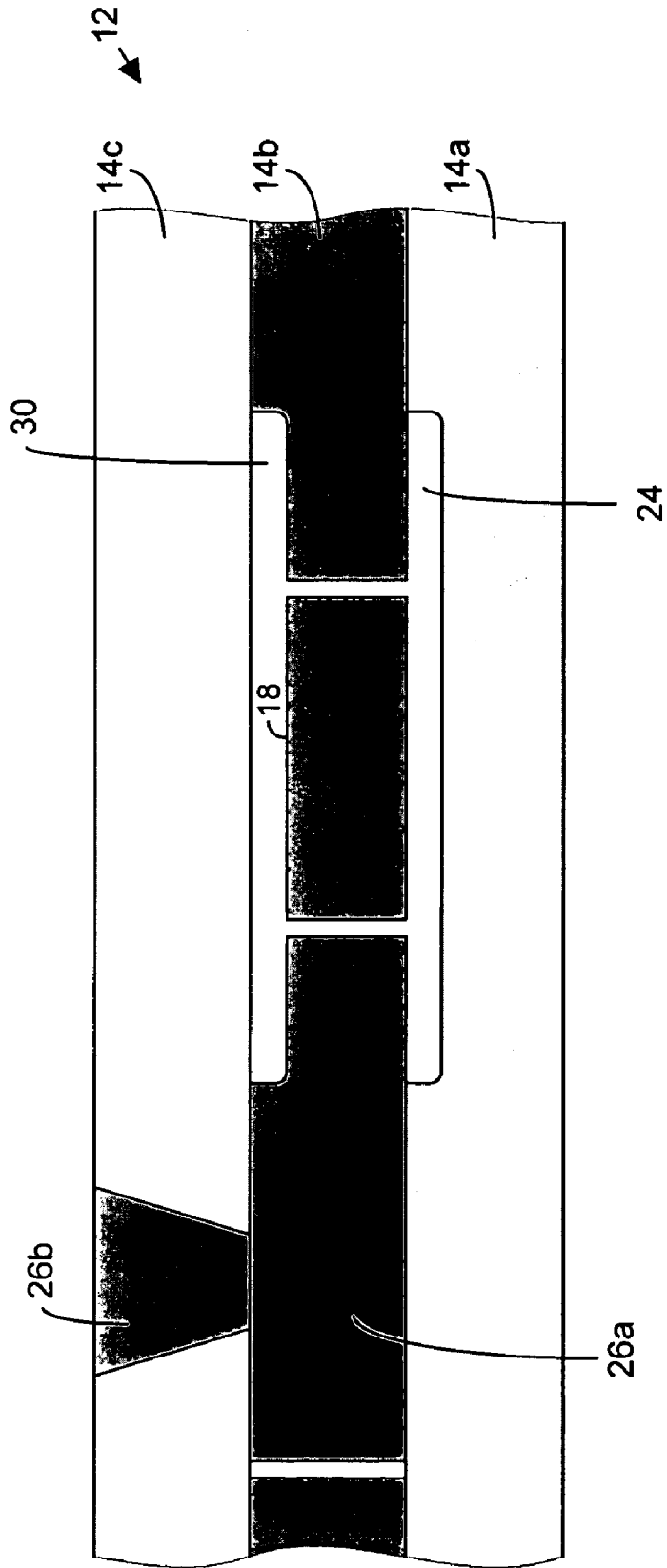

FIGURE 15G

10

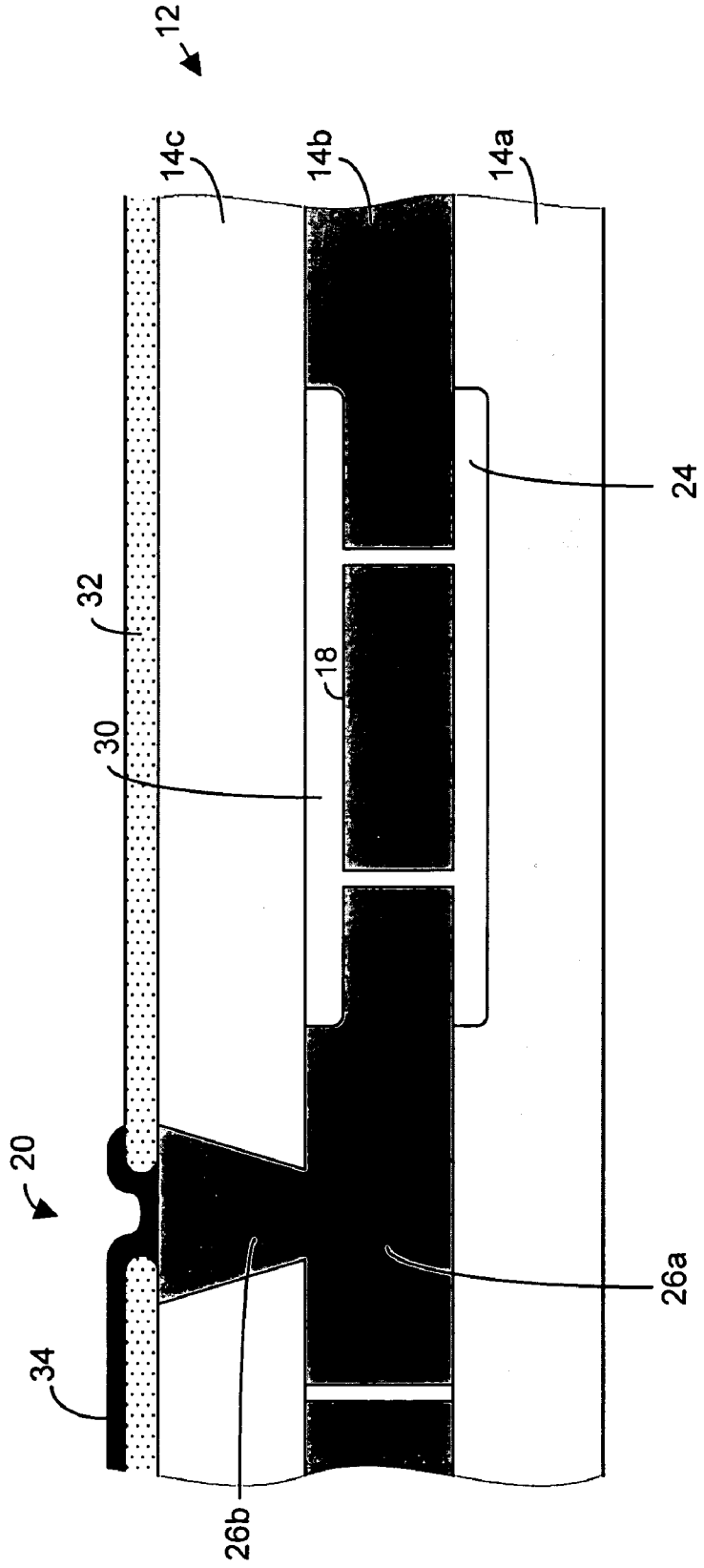

FIGURE 15H

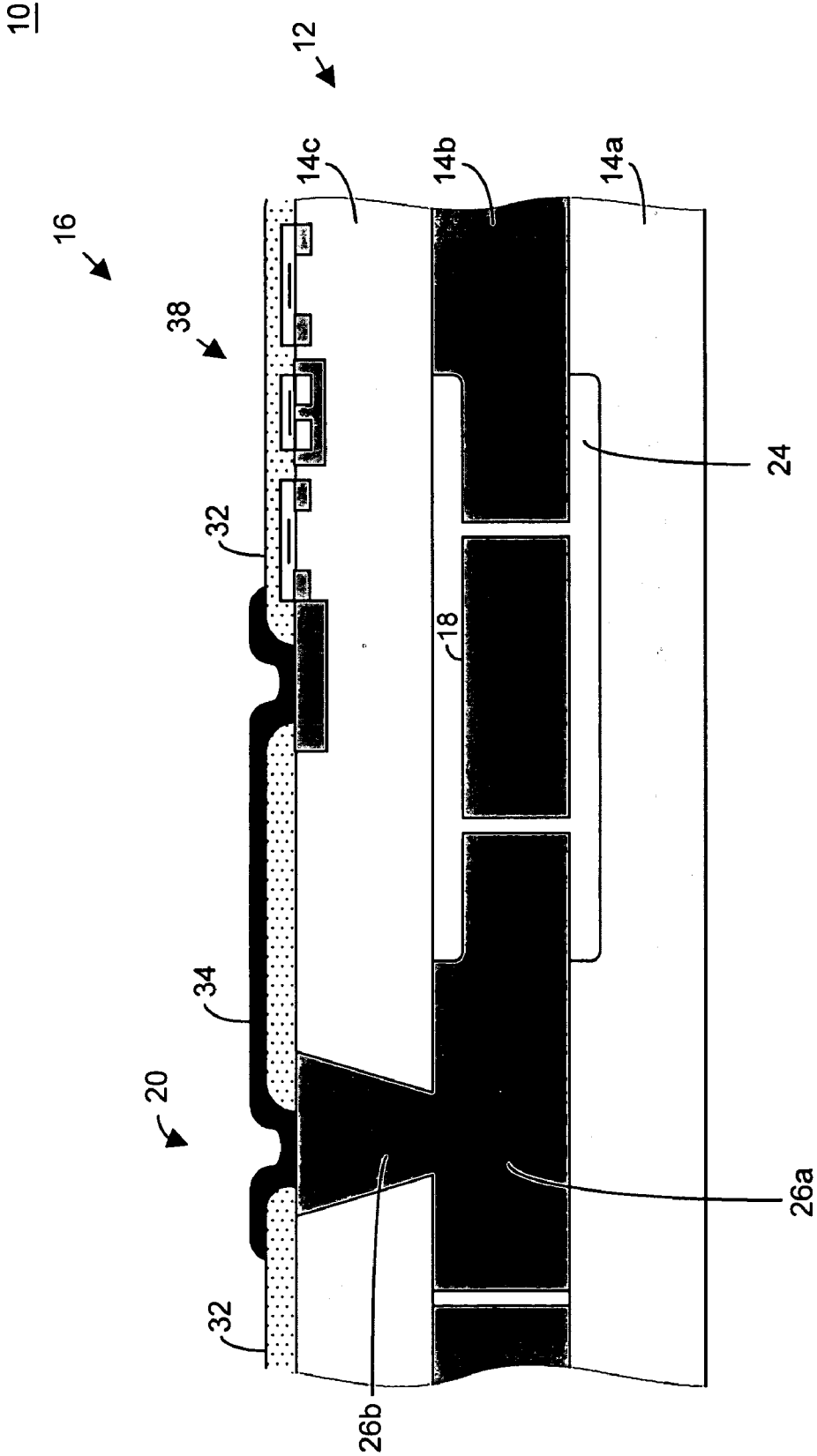

FIGURE 16

10

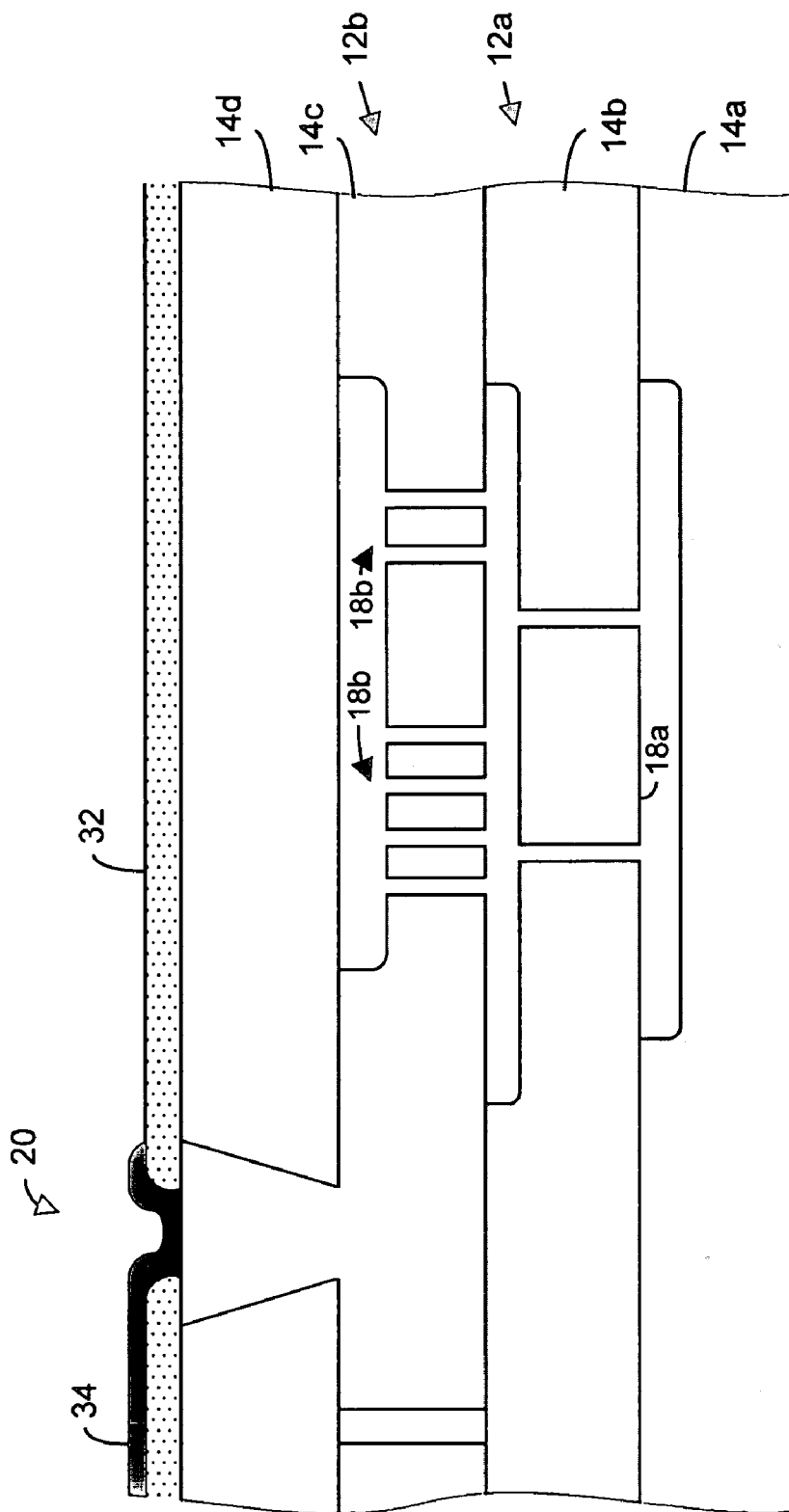

FIGURE 17

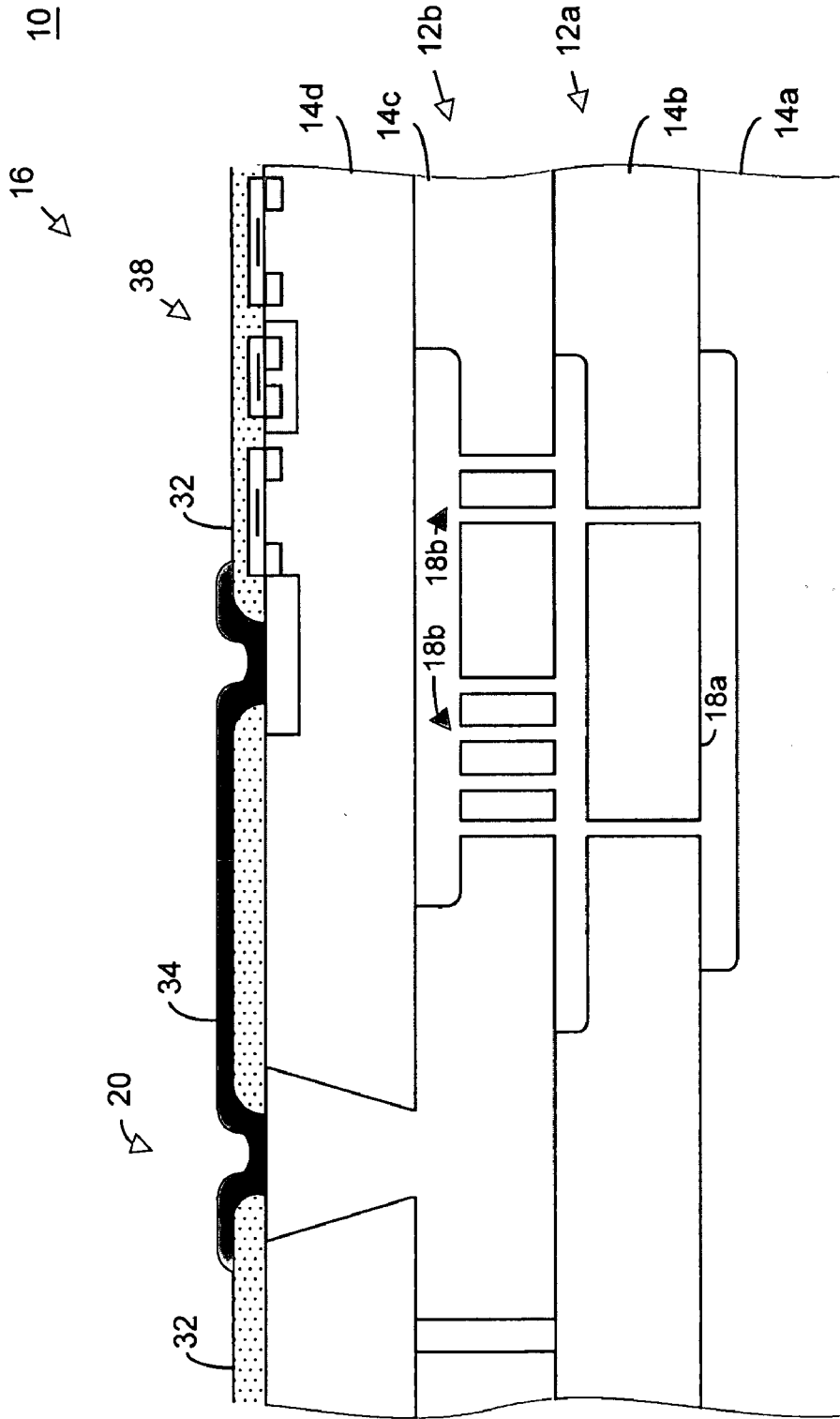

FIGURE 18

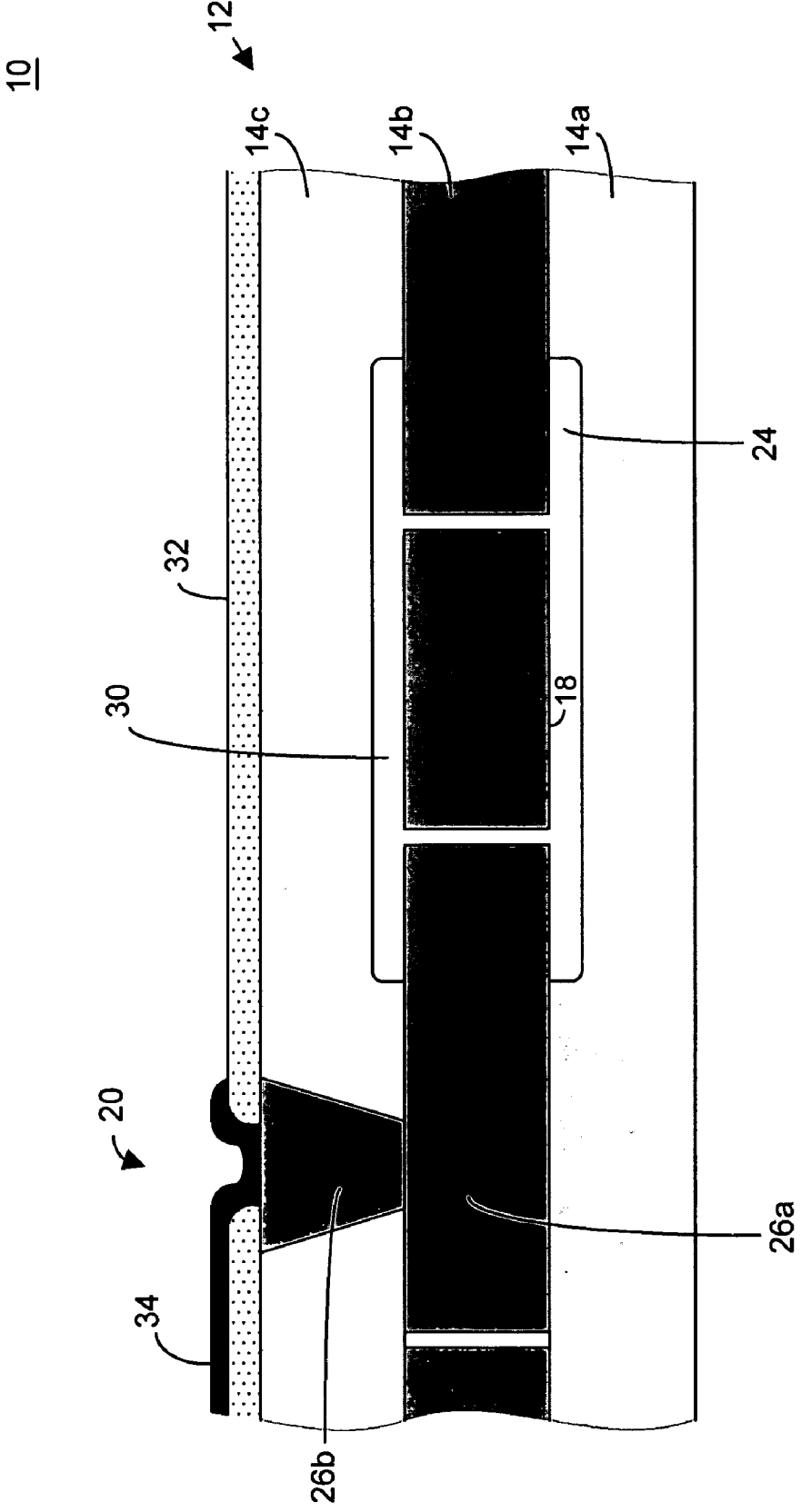

FIGURE 19



FIGURE 20A

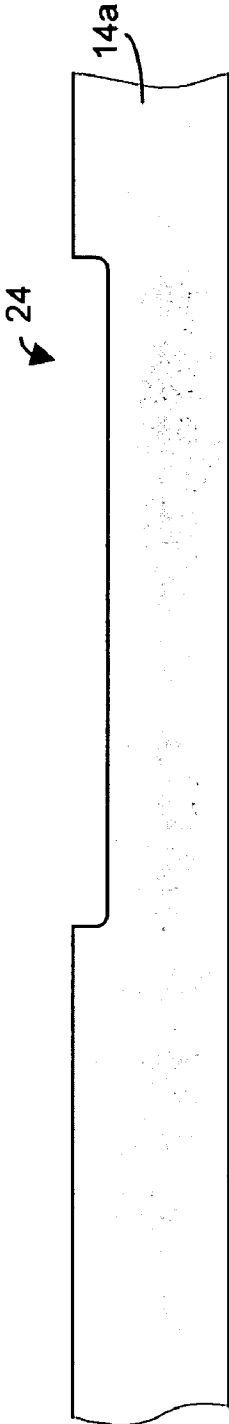

FIGURE 20B

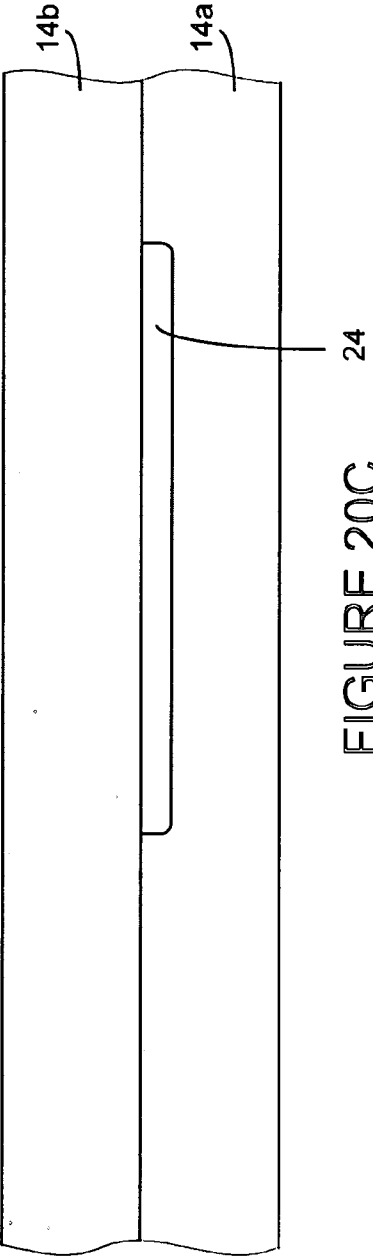

FIGURE 20C

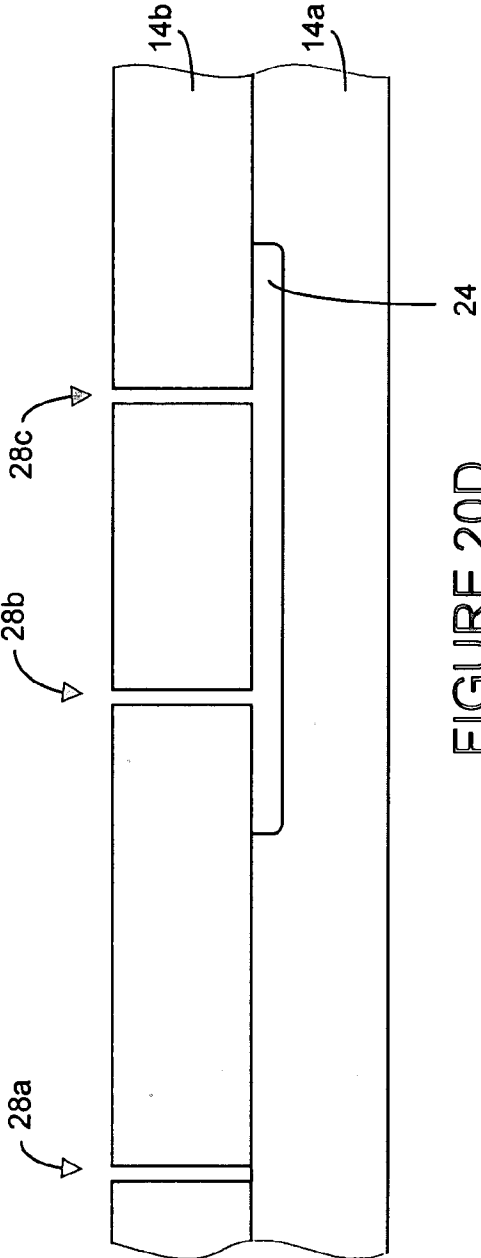

FIGURE 20D

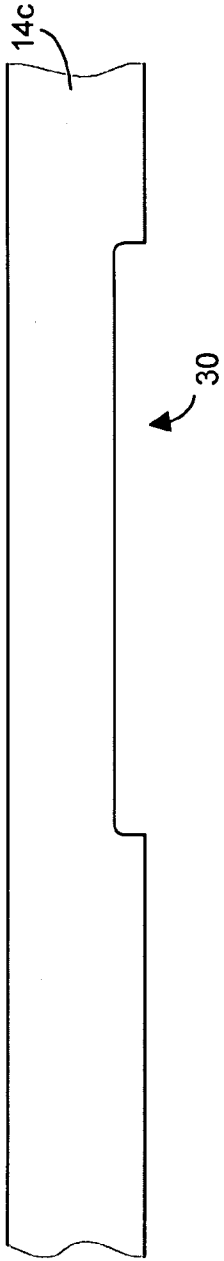

FIGURE 20E

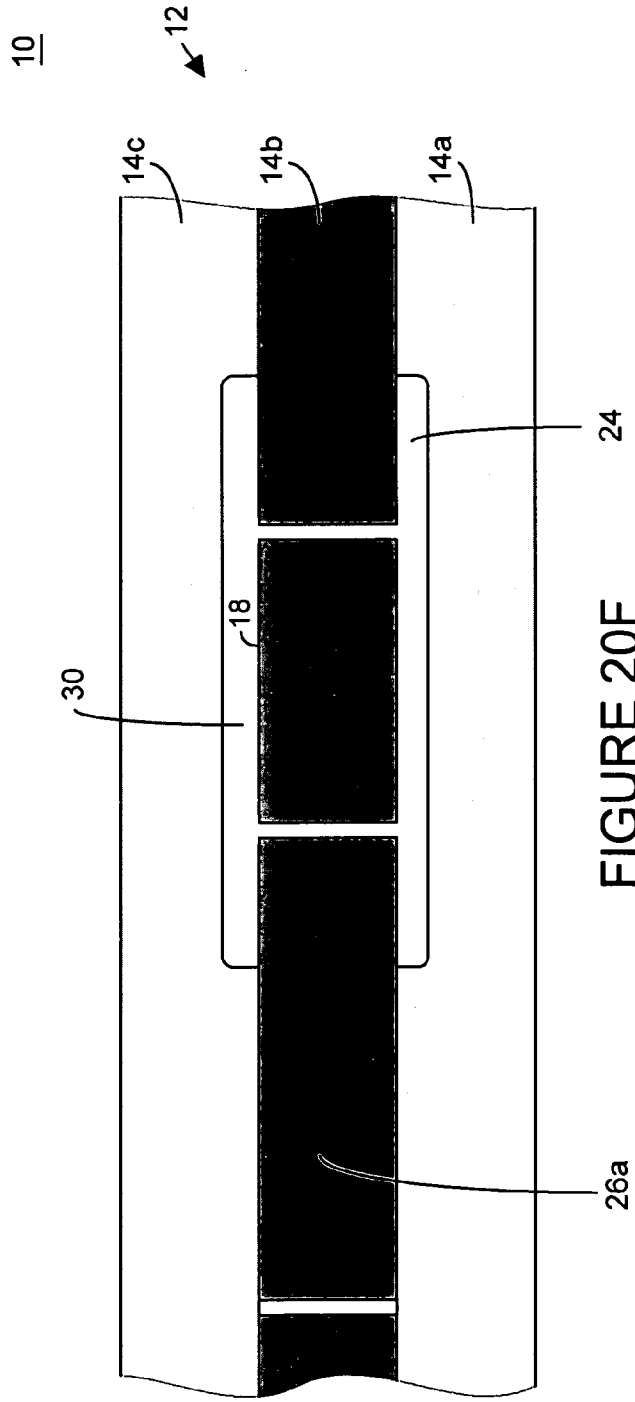
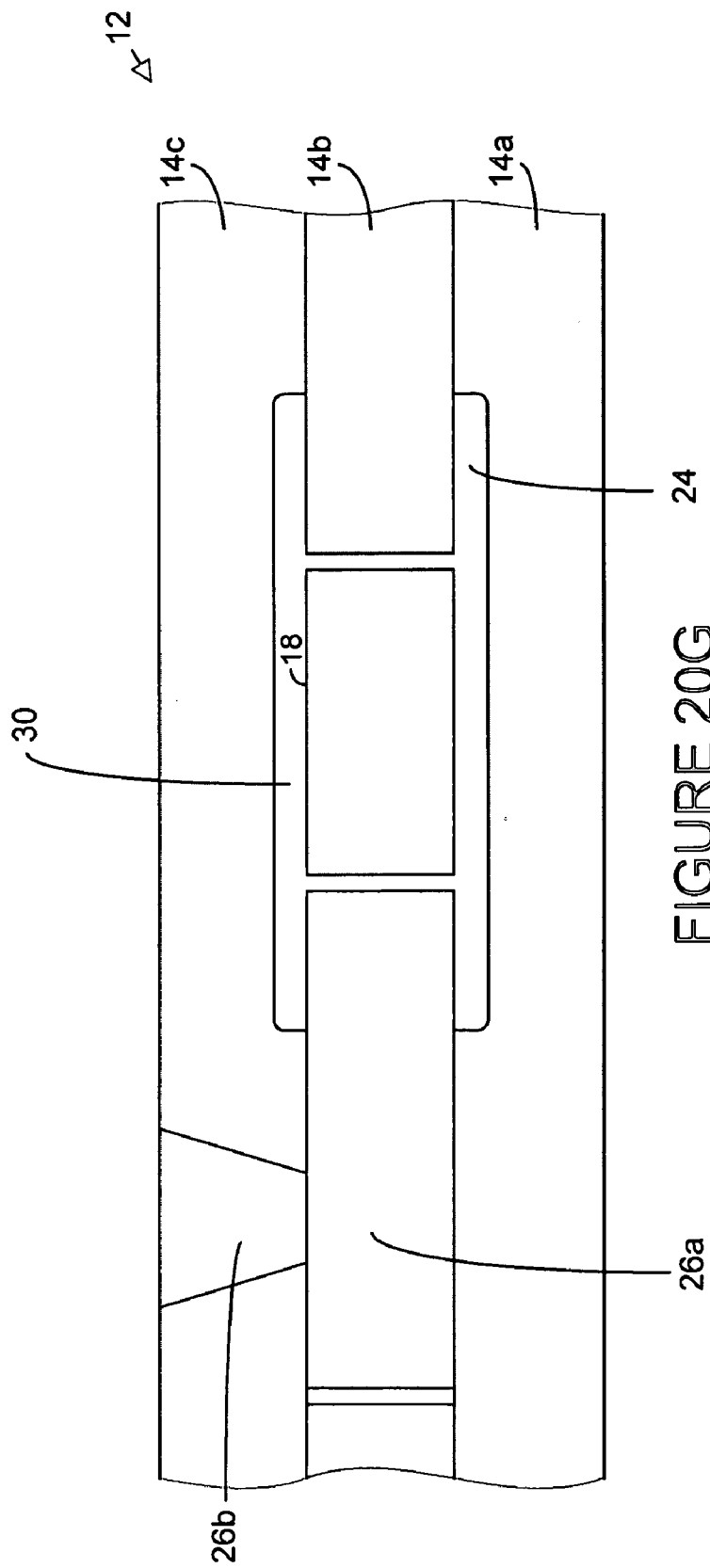

FIGURE 20F

10



10

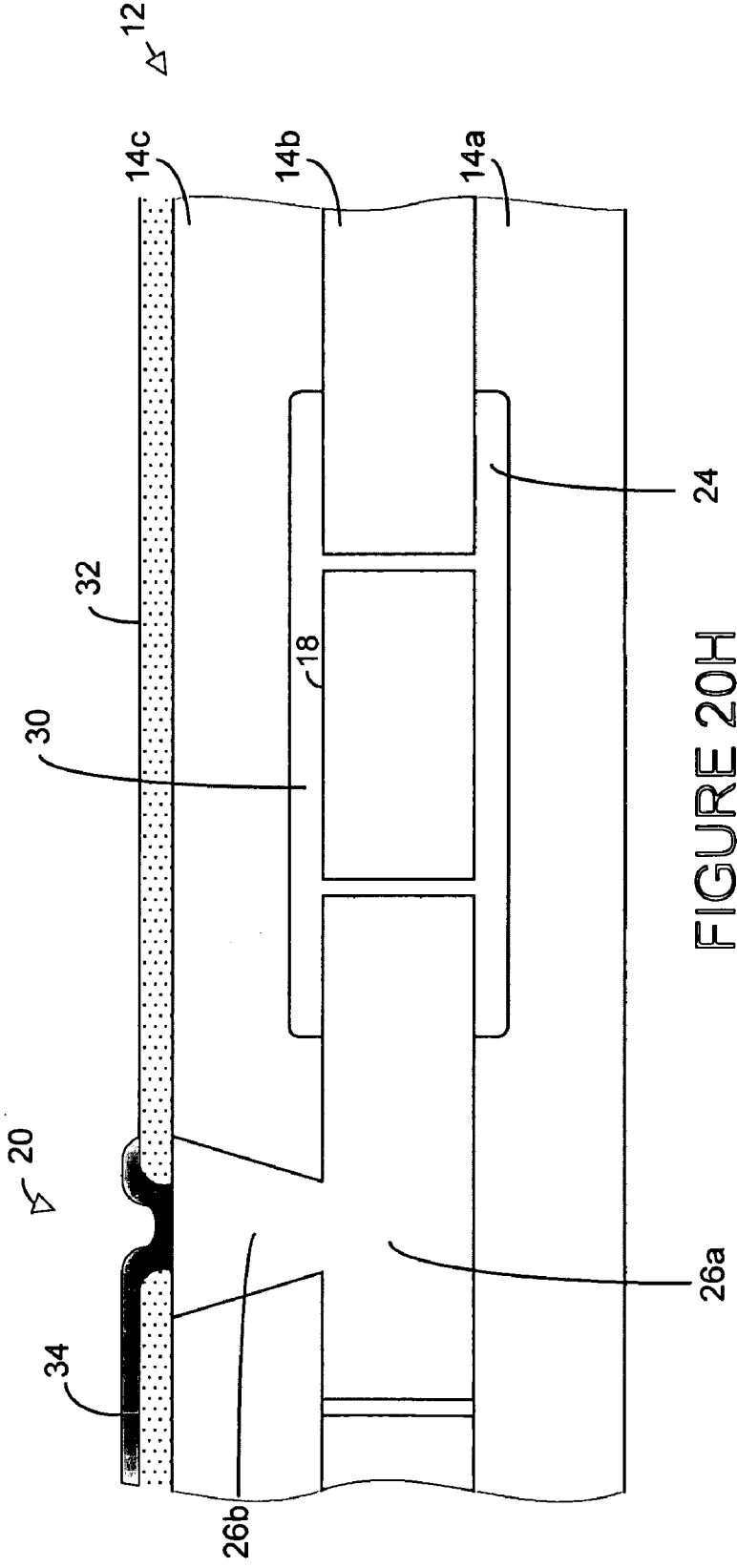

FIGURE 20H

10

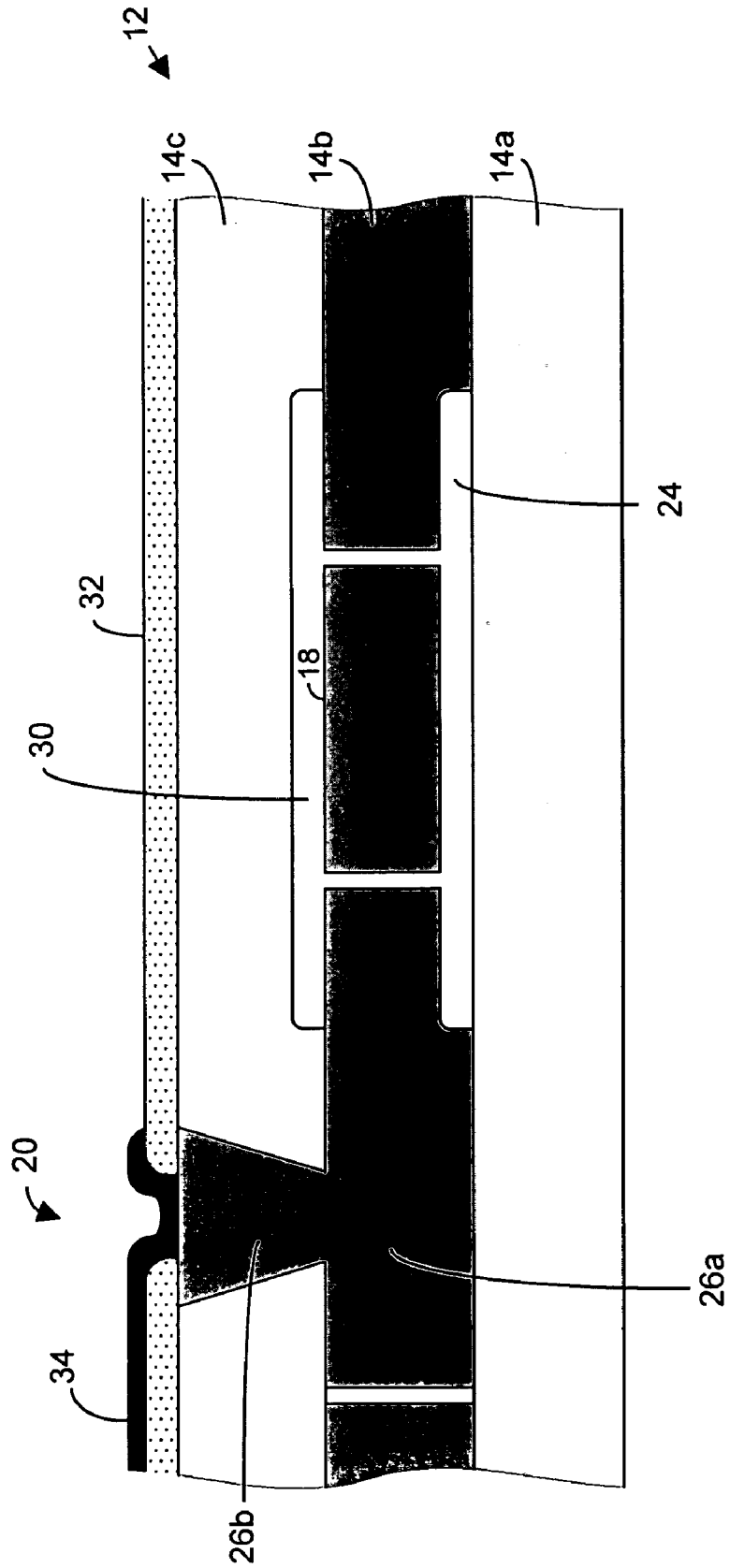

FIGURE 21

10

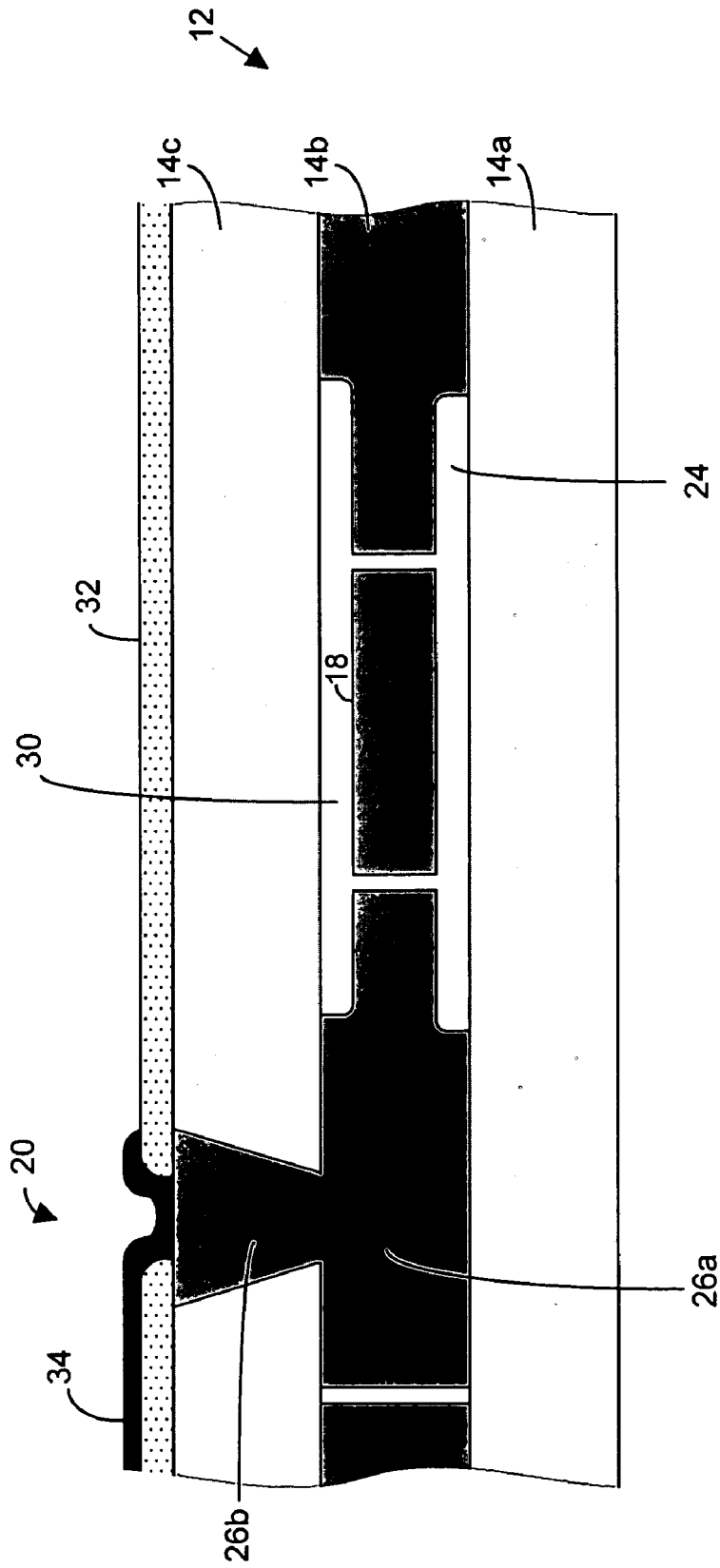

FIGURE 22

10

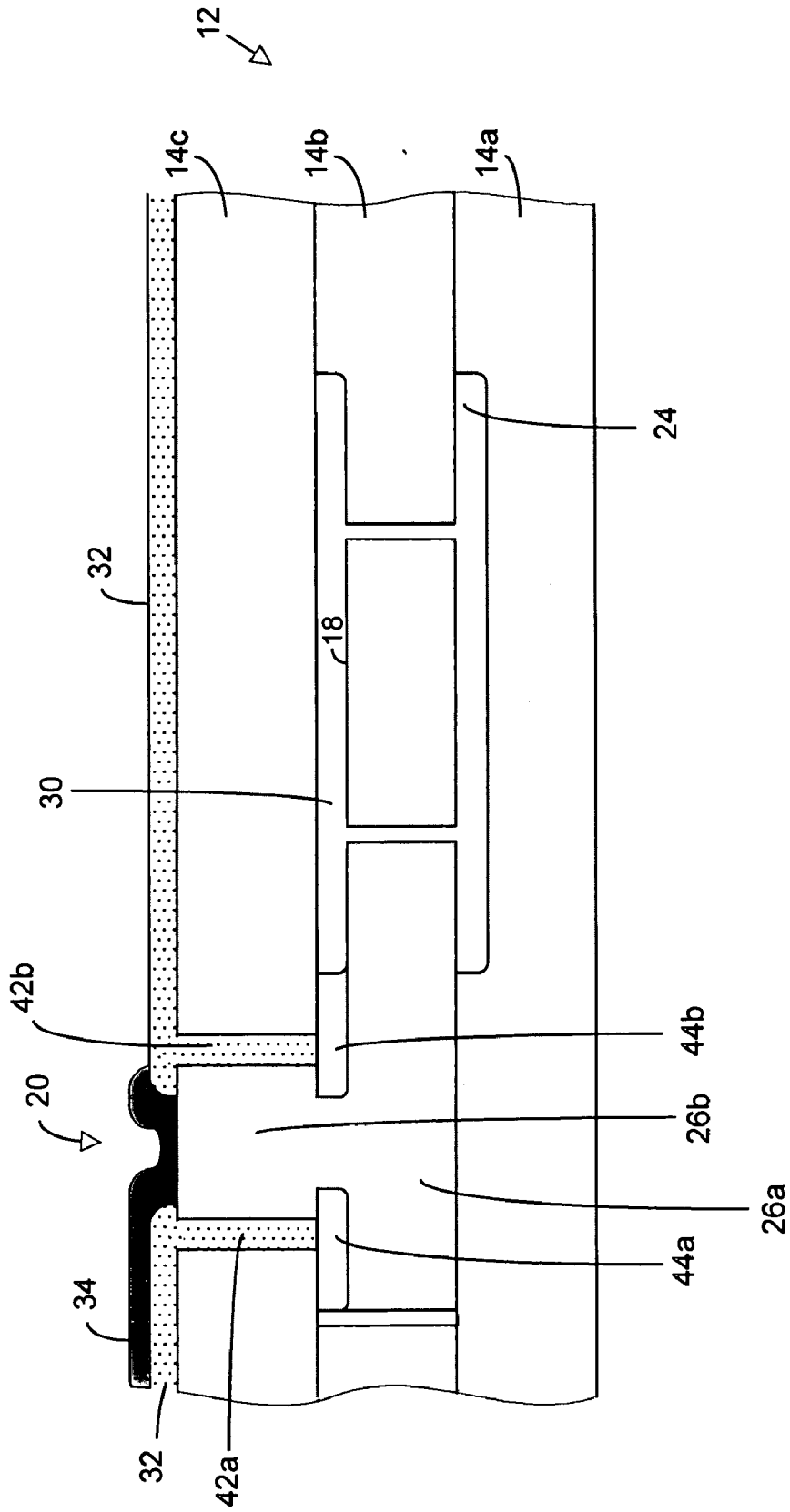

FIGURE 23

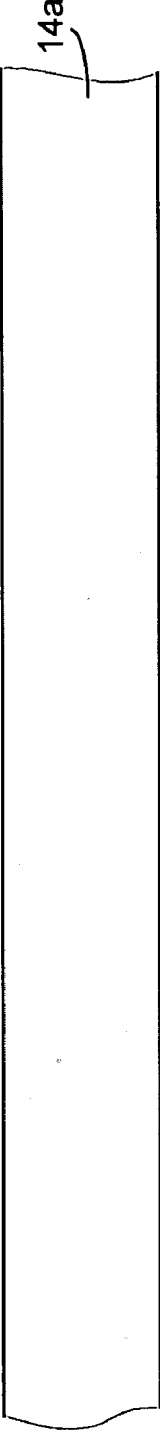

FIGURE 24A

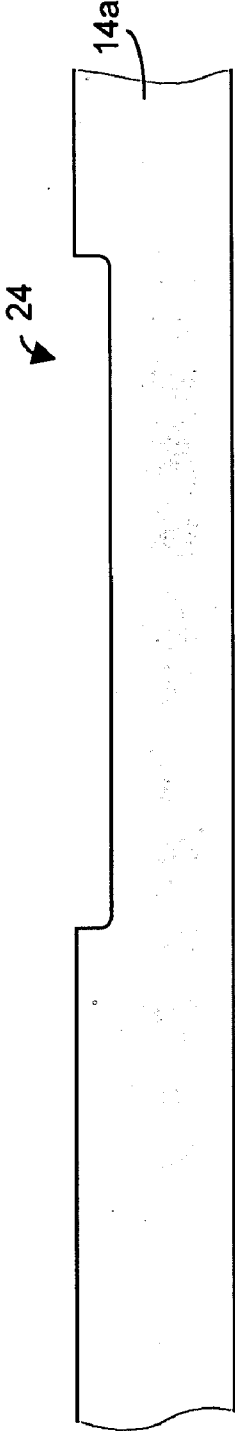

FIGURE 24B

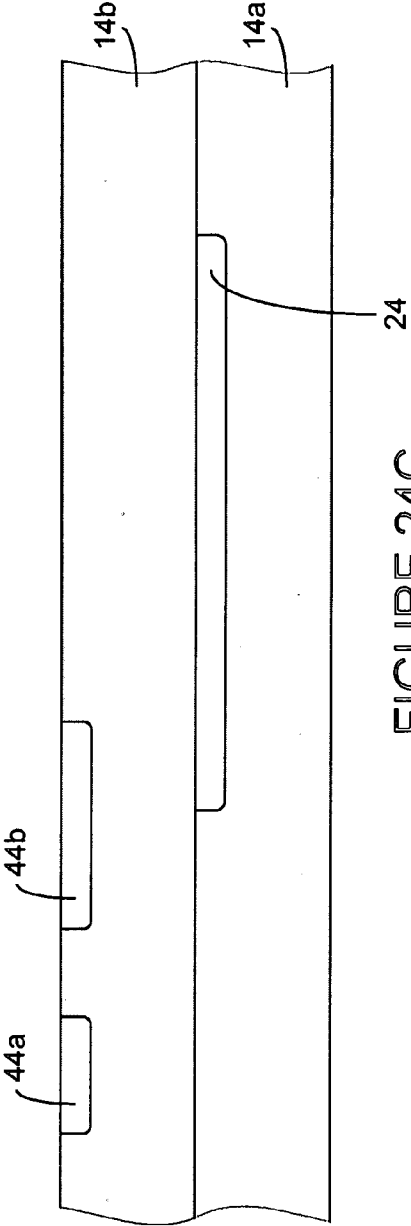

FIGURE 24C

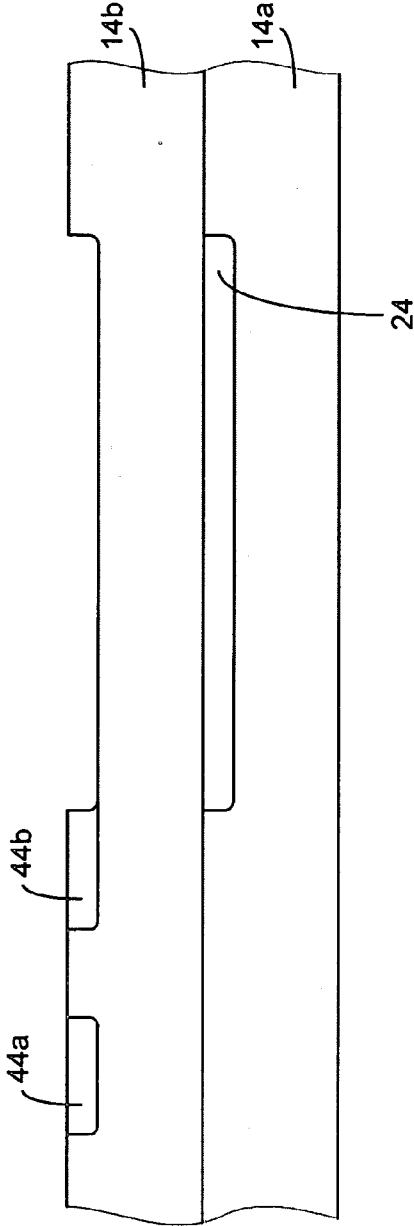

FIGURE 24D

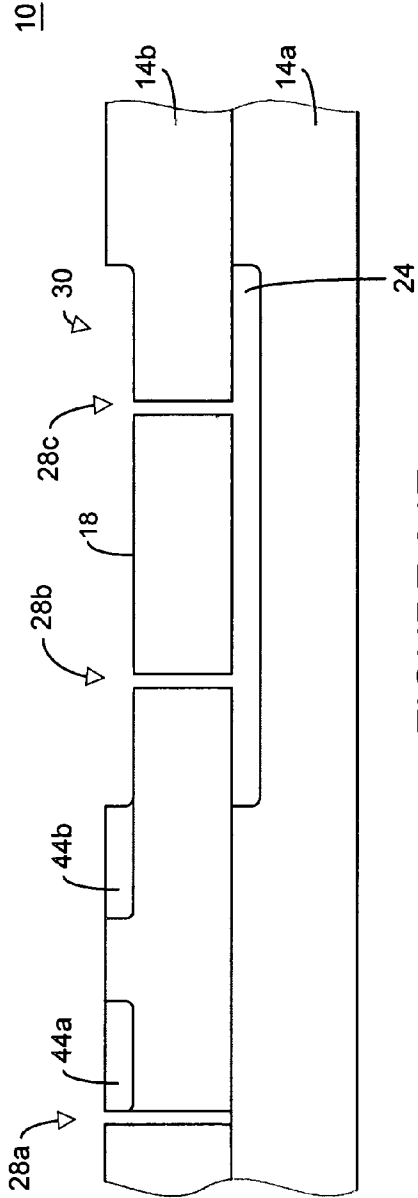

FIGURE 24E

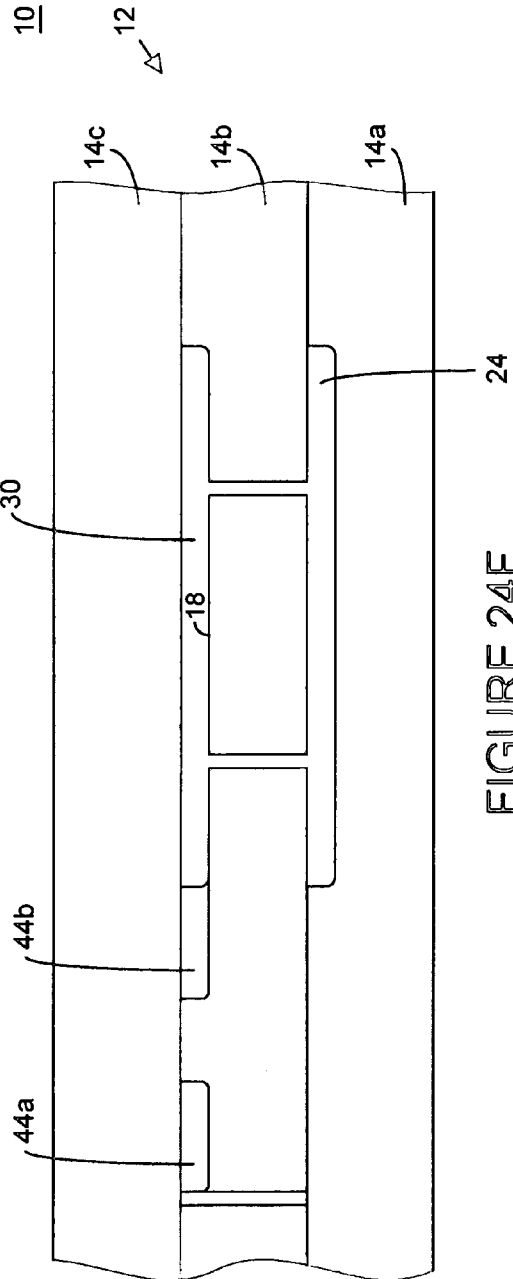

FIGURE 24F

10

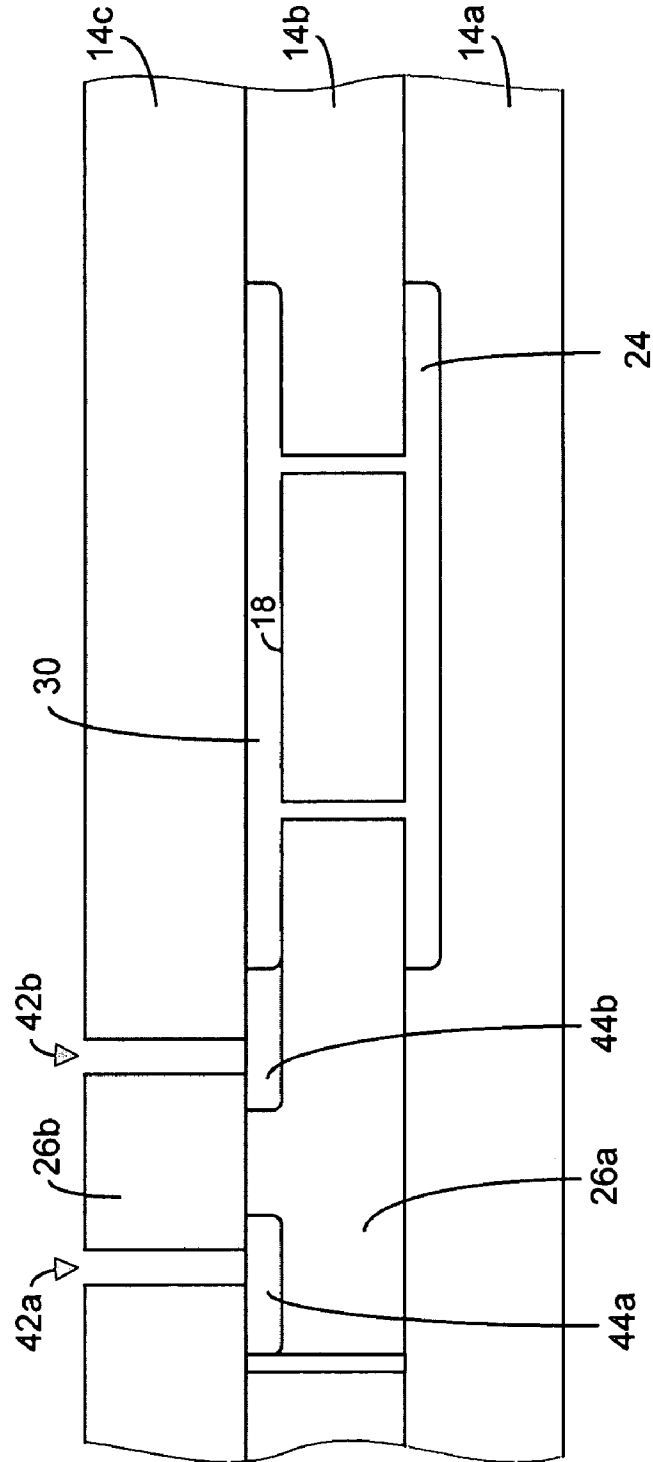

FIGURE 24G

10

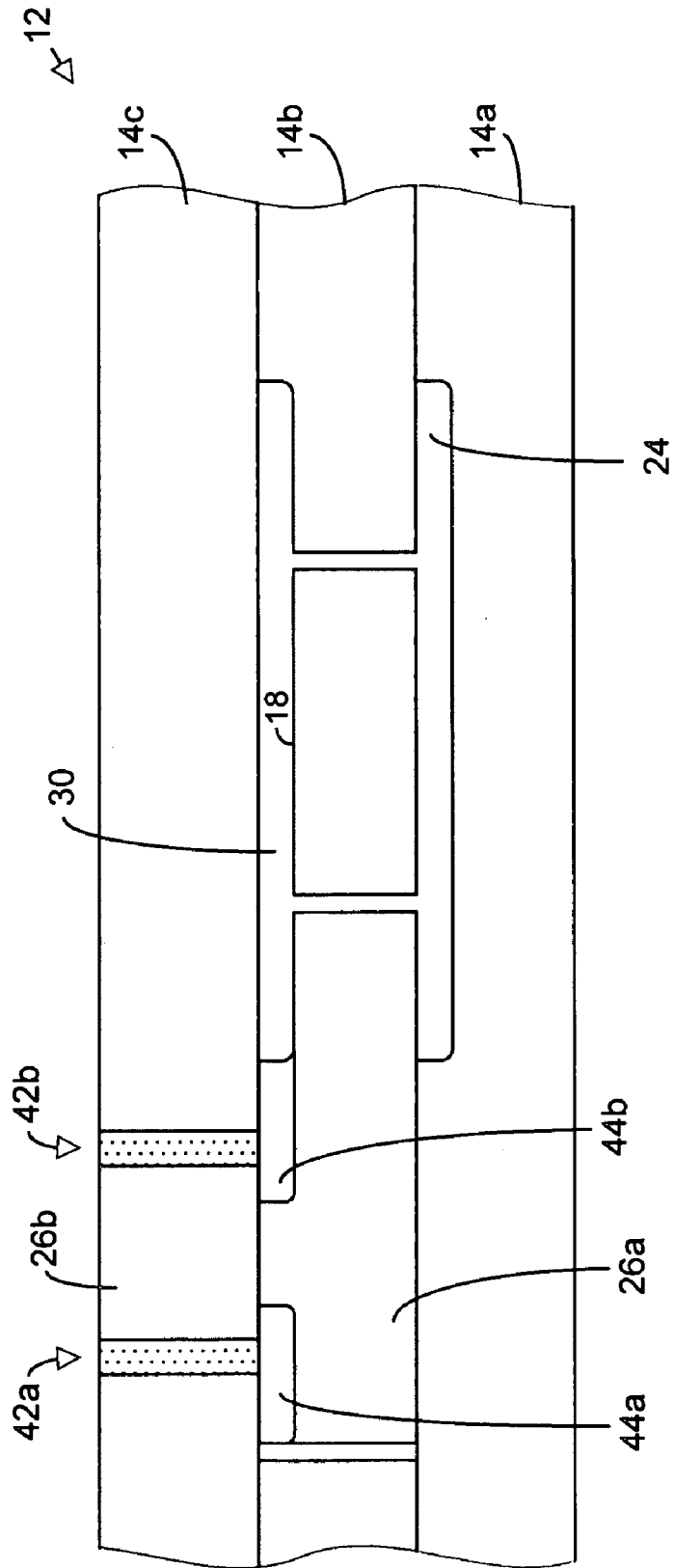

FIGURE 24H

10

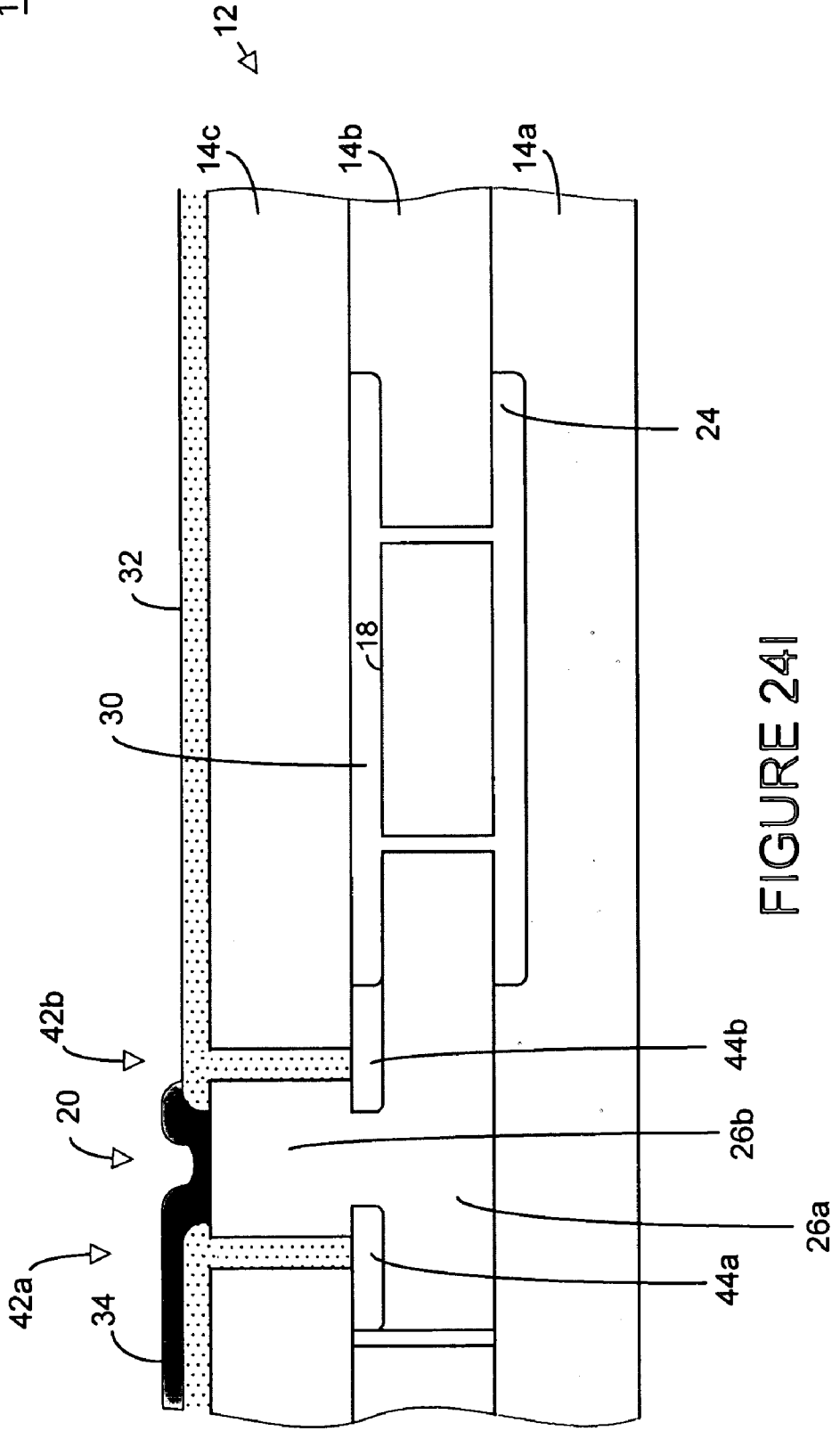

FIGURE 24I

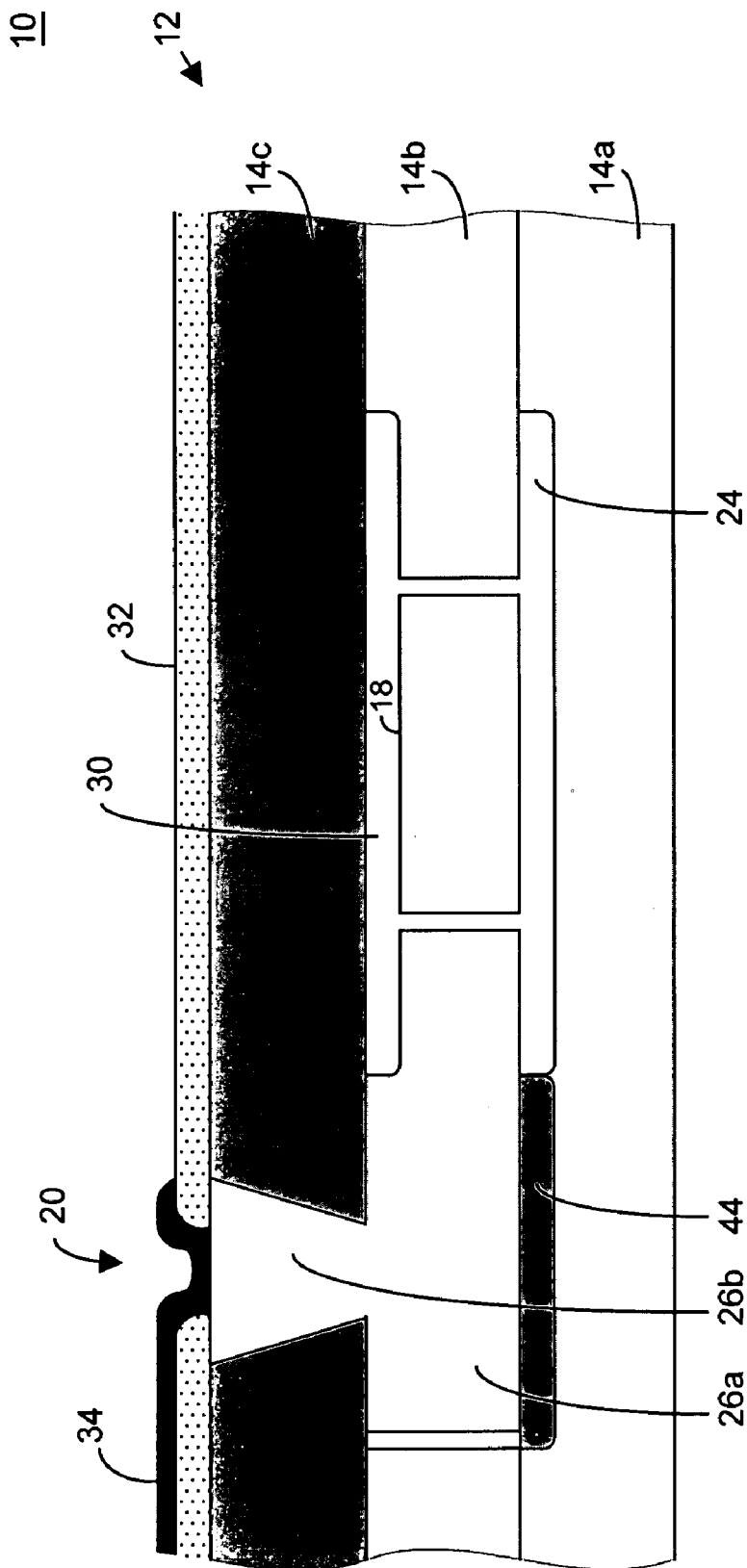

FIGURE 25

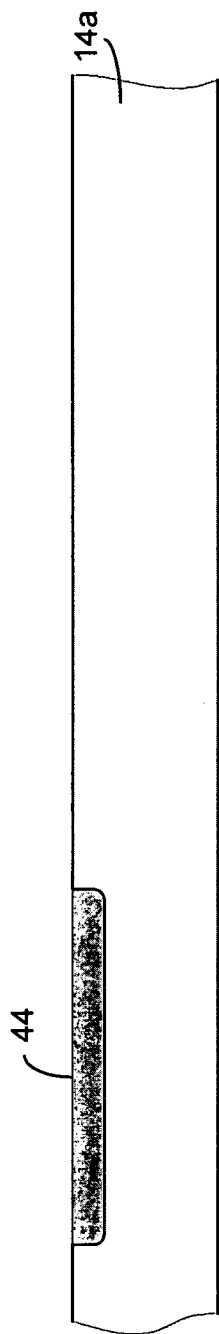

FIGURE 26A

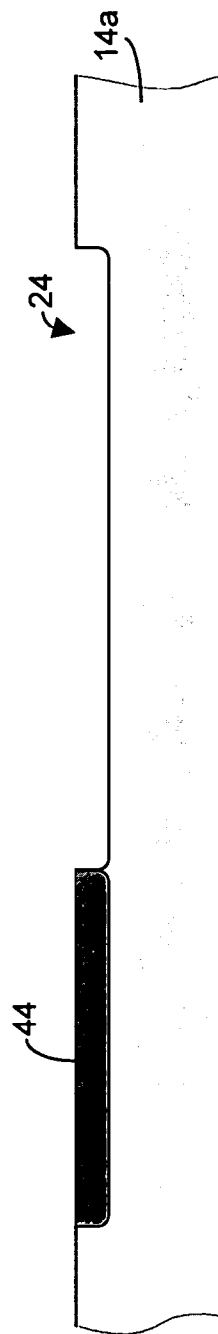

FIGURE 26B

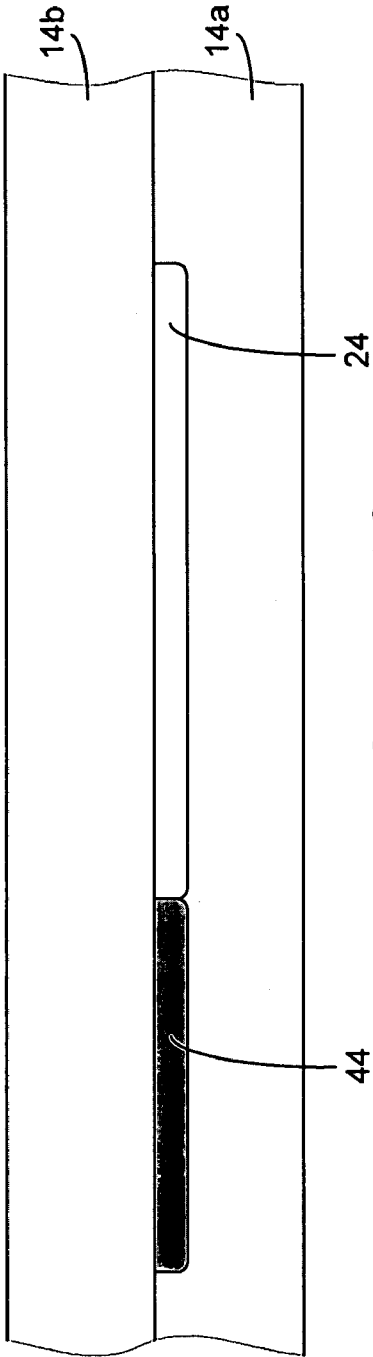

FIGURE 26C

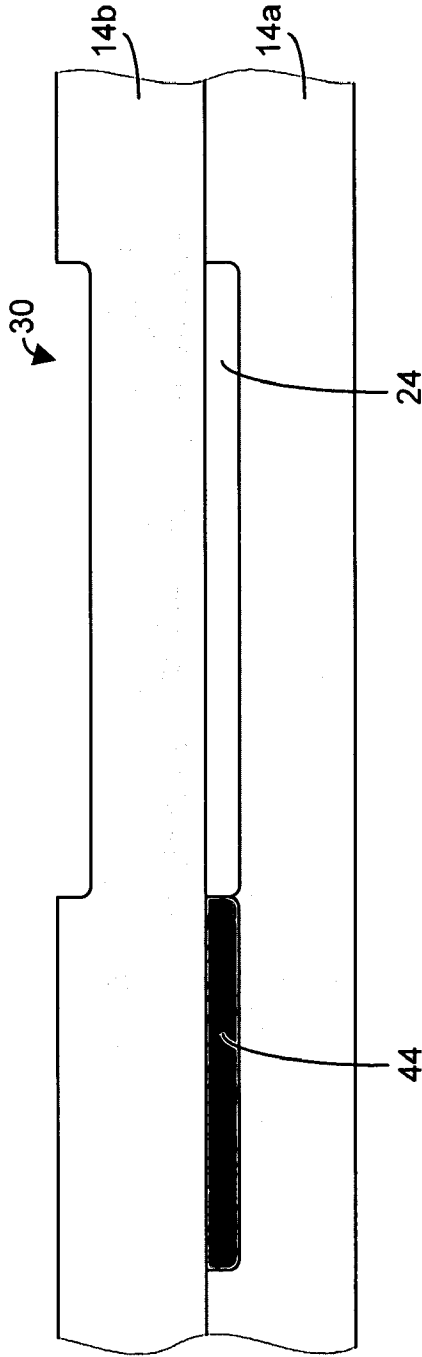
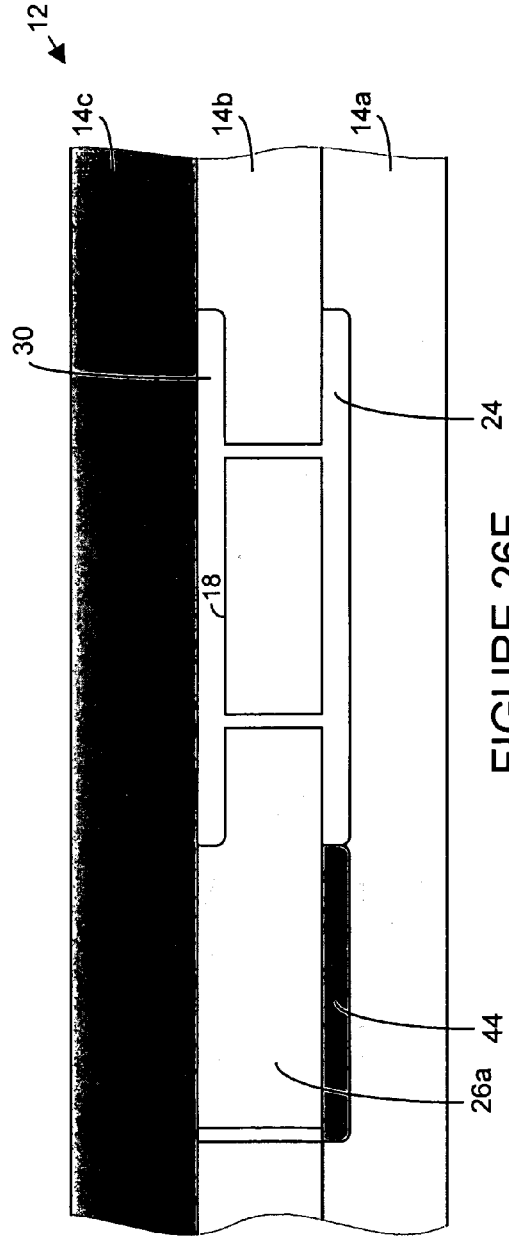
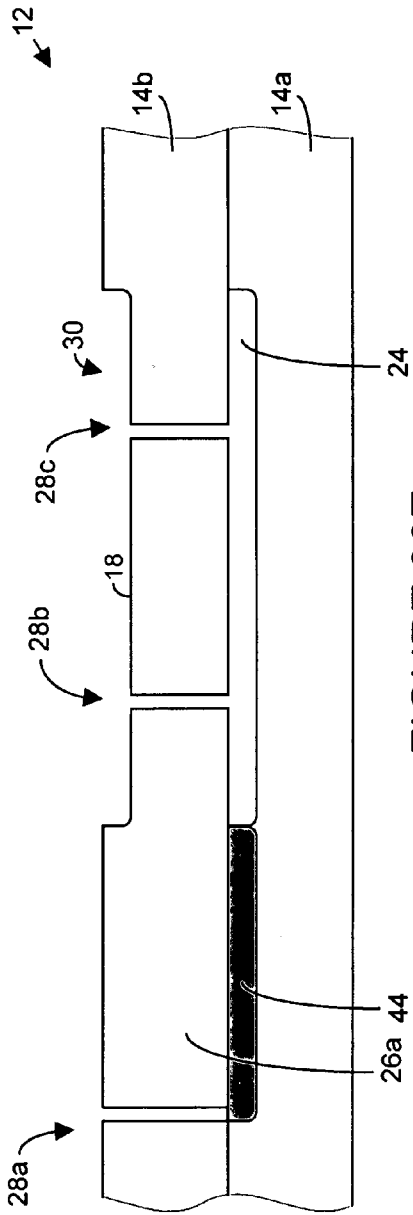

FIGURE 26D



10

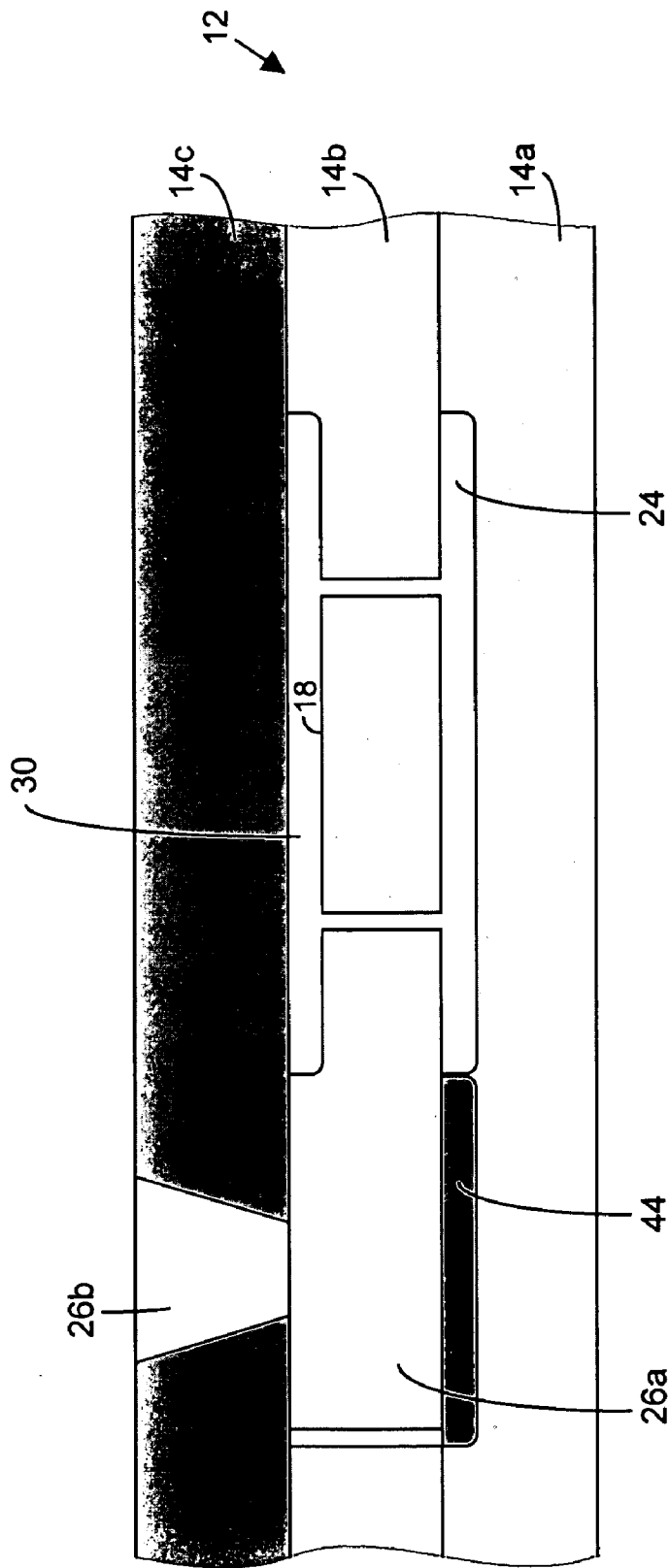

FIGURE 26G

10

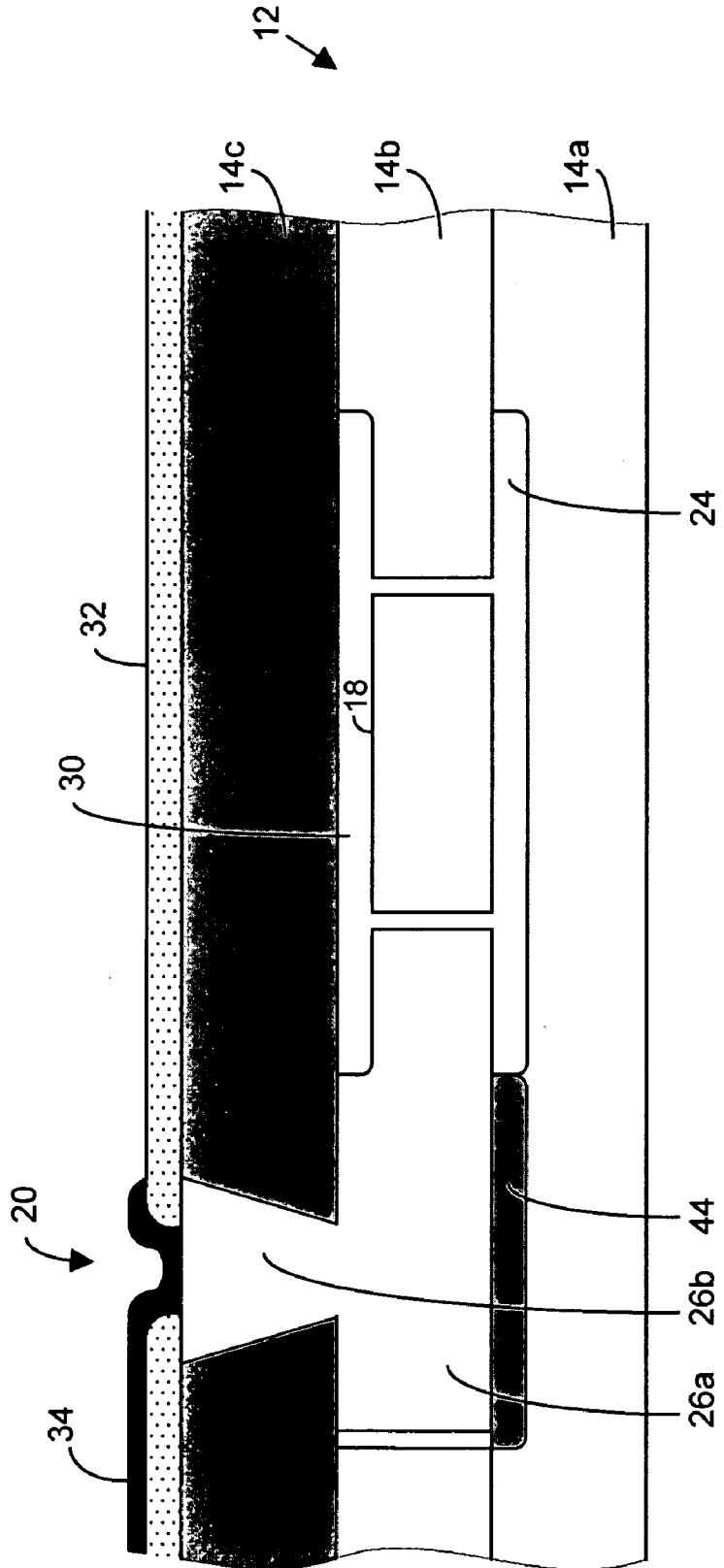

FIGURE 26H

10

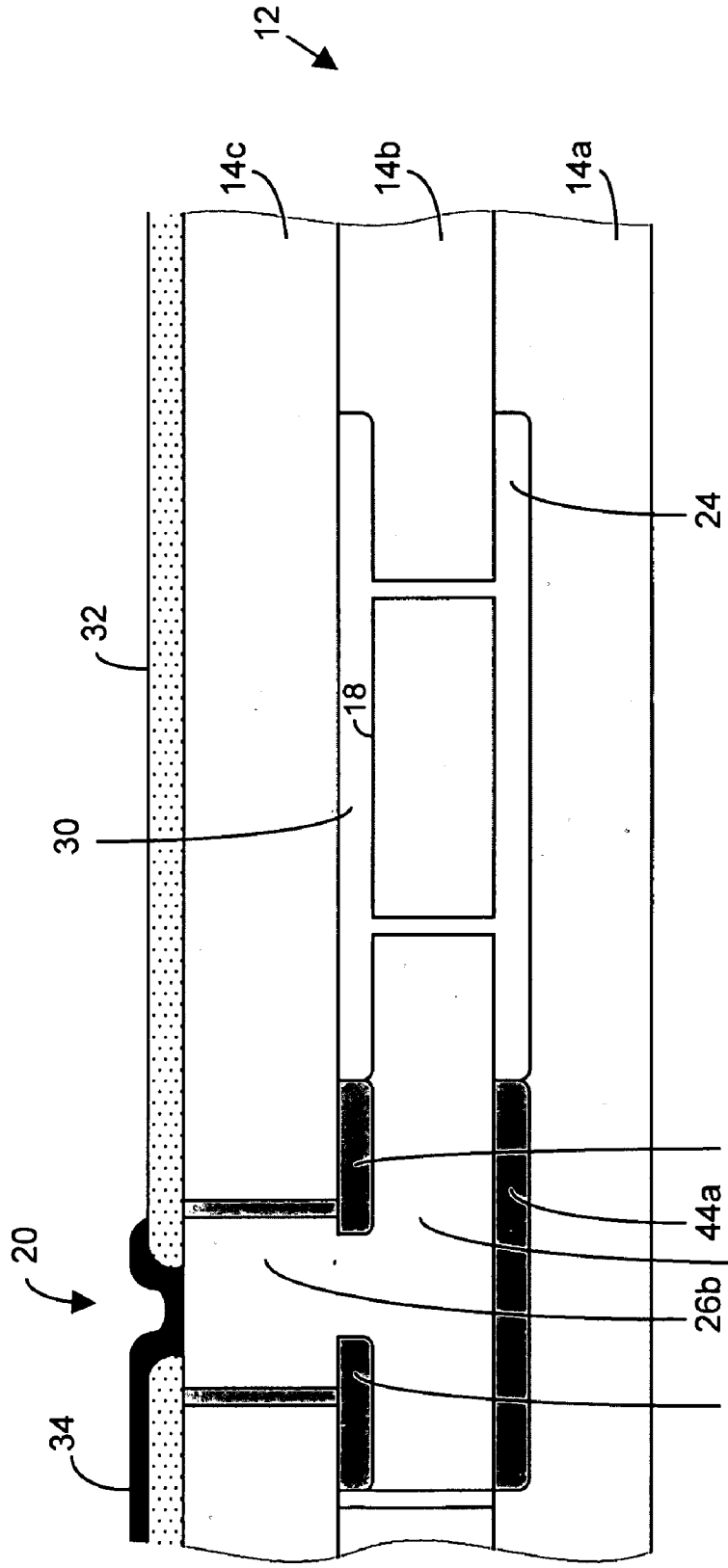

FIGURE 27

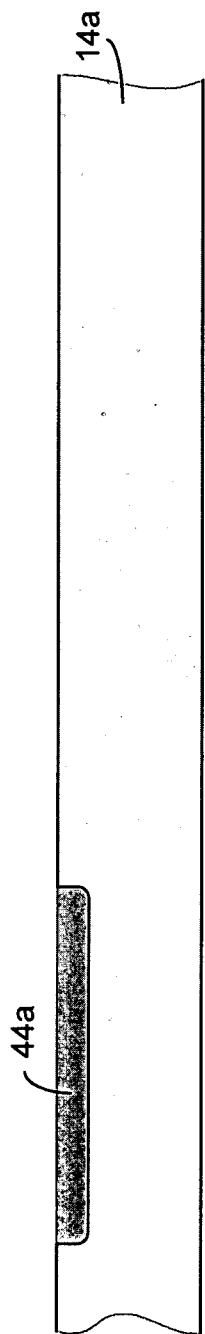

FIGURE 28A

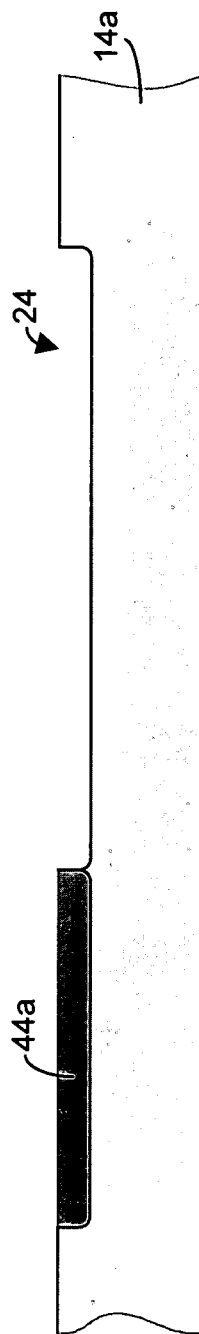

FIGURE 28B

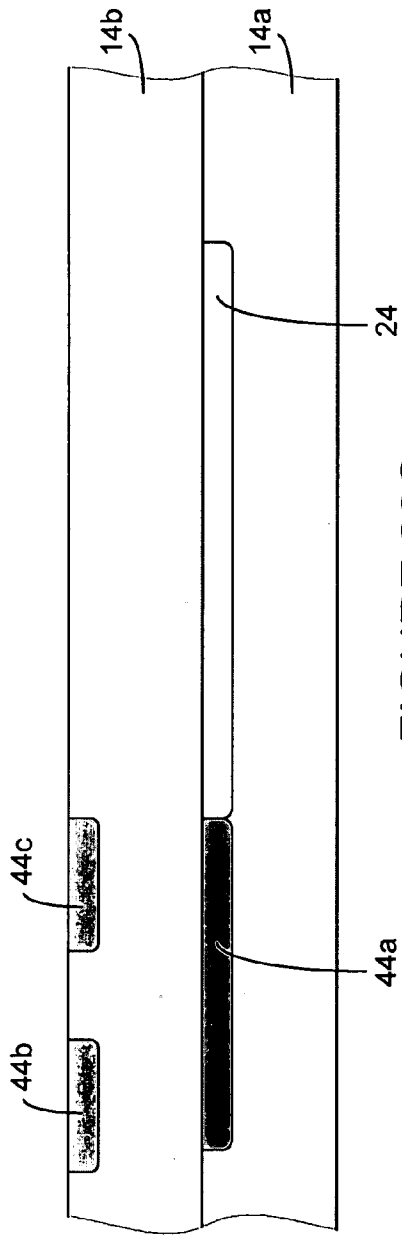

FIGURE 28C

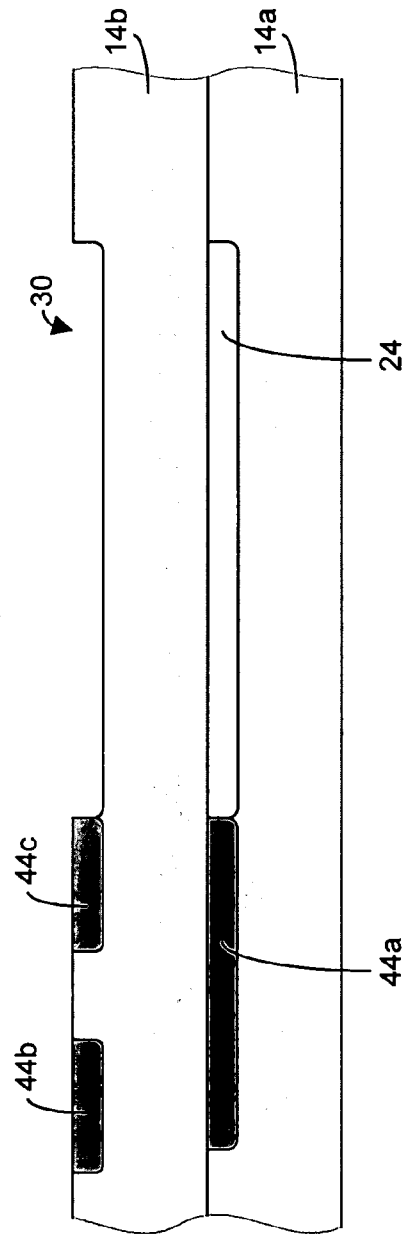

FIGURE 28D

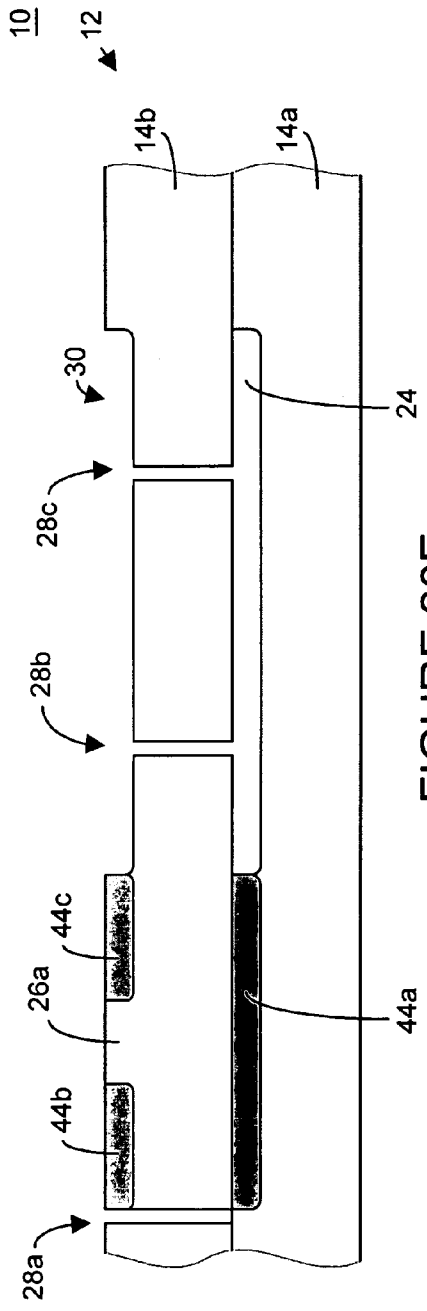

FIGURE 28E

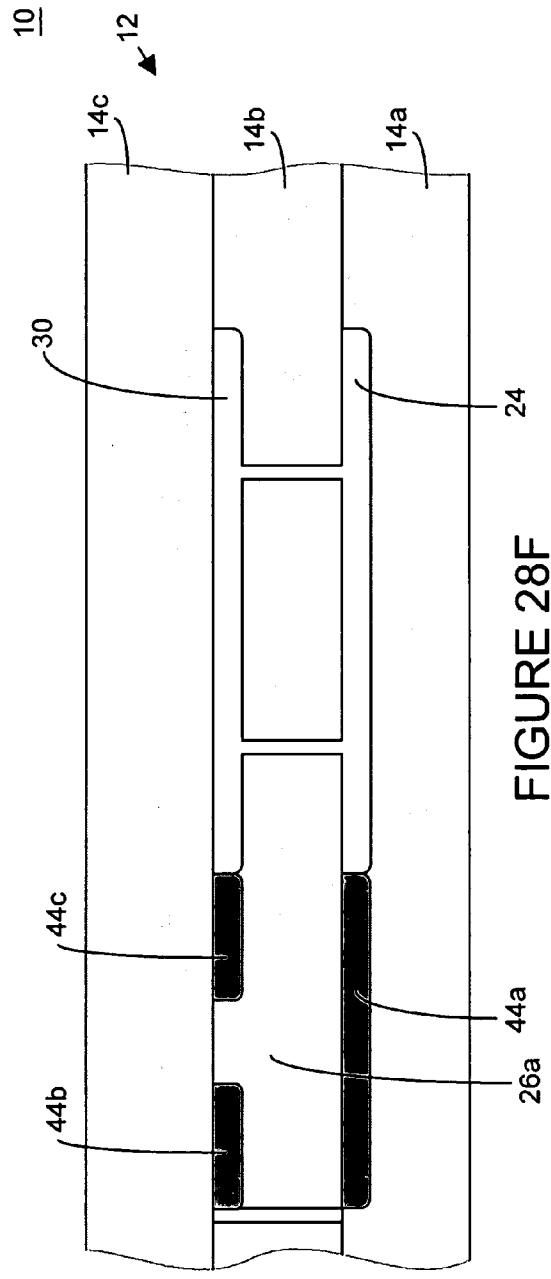

FIGURE 28F

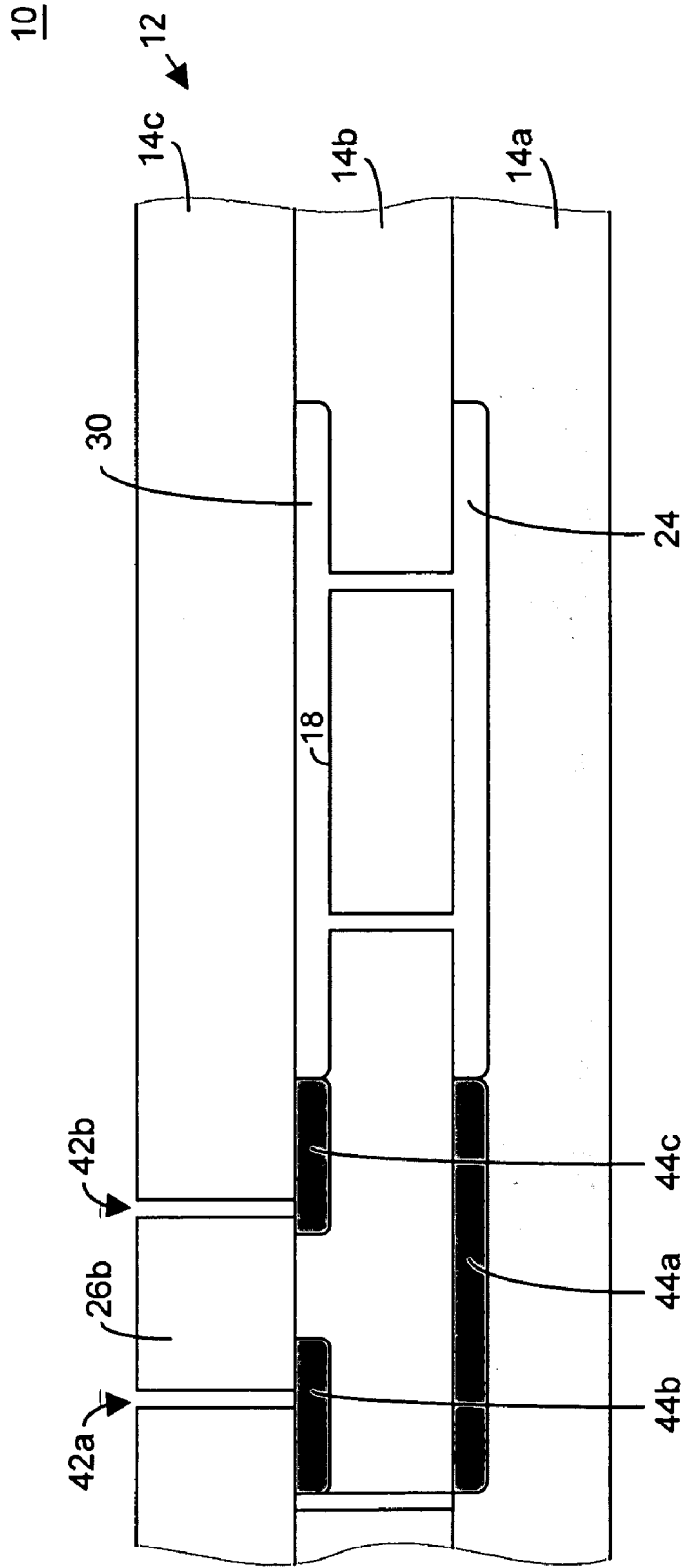

FIGURE 28G

10

12

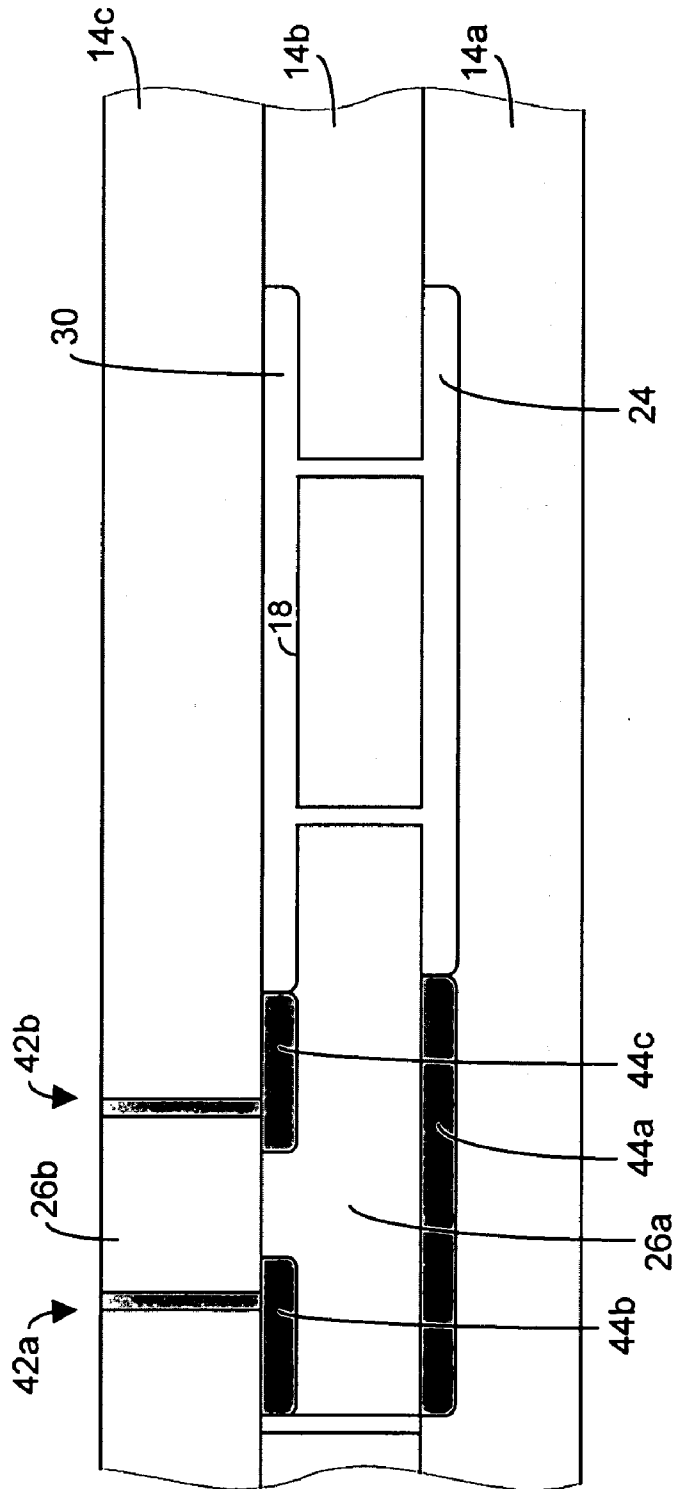

FIGURE 28H

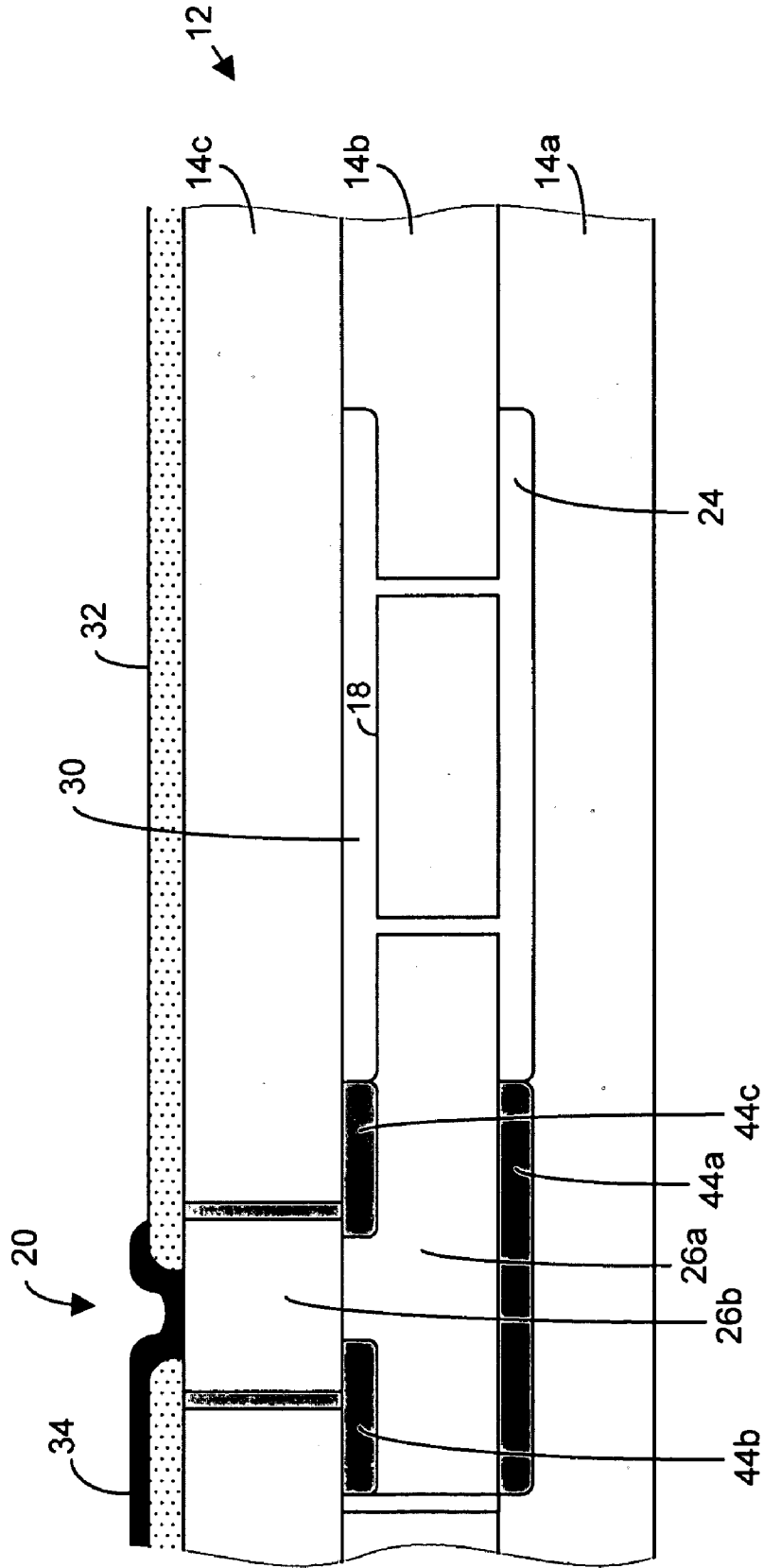

FIGURE 28I

10

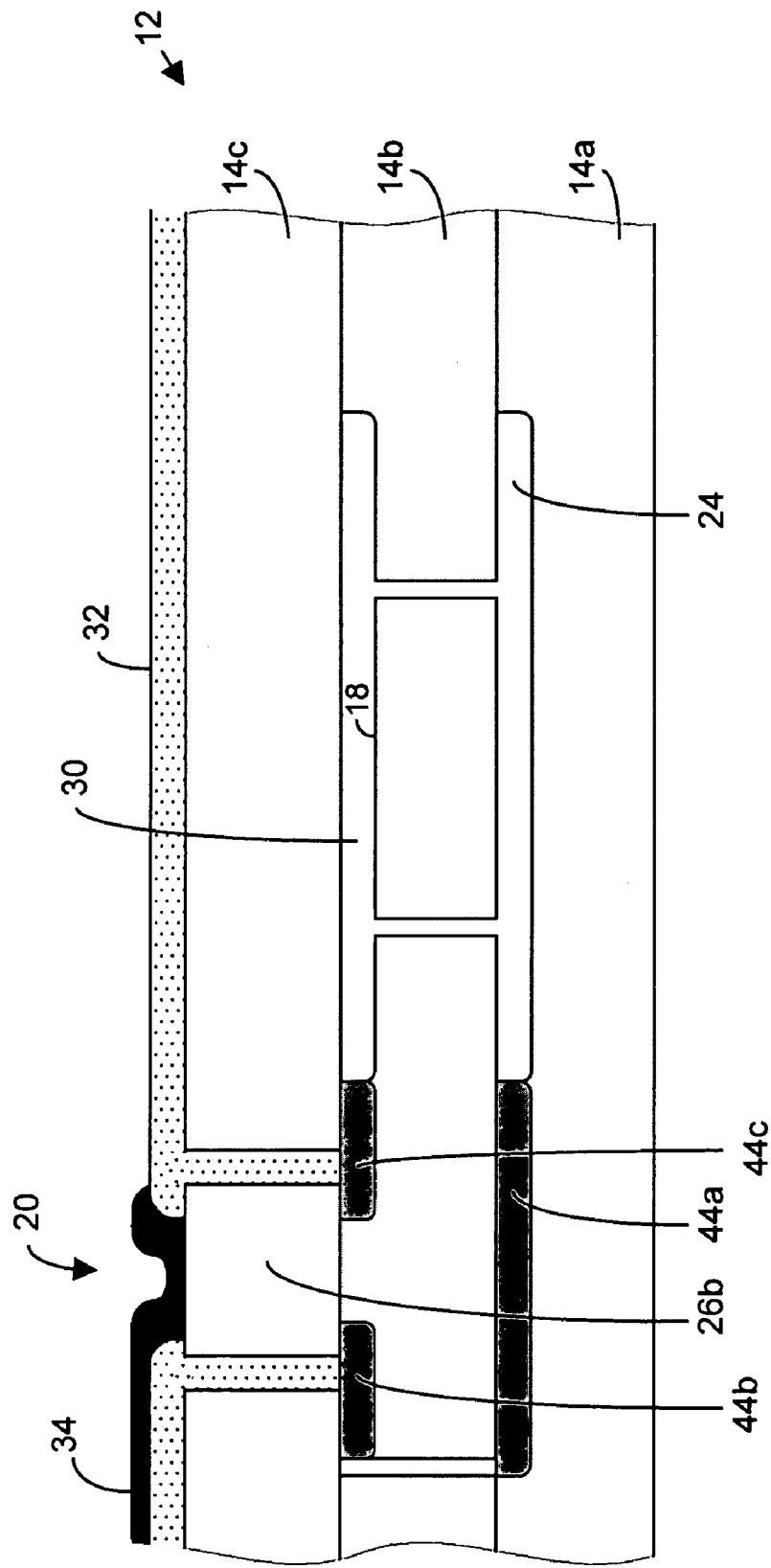

FIGURE 29

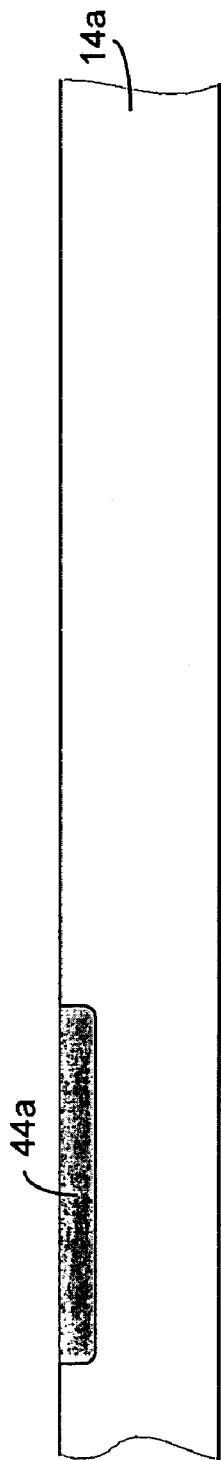

FIGURE 30A

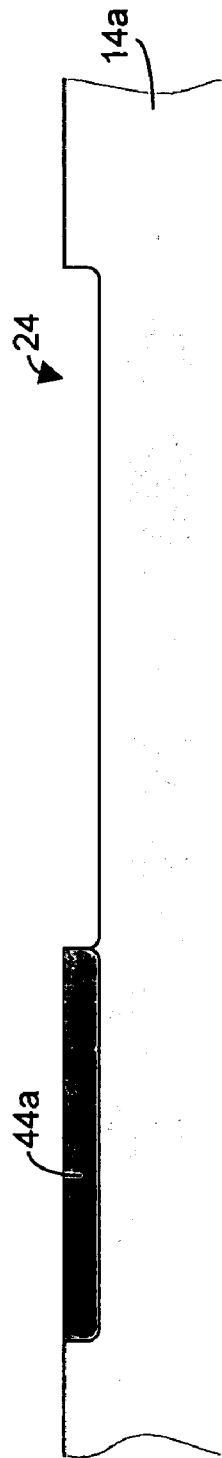

FIGURE 30B

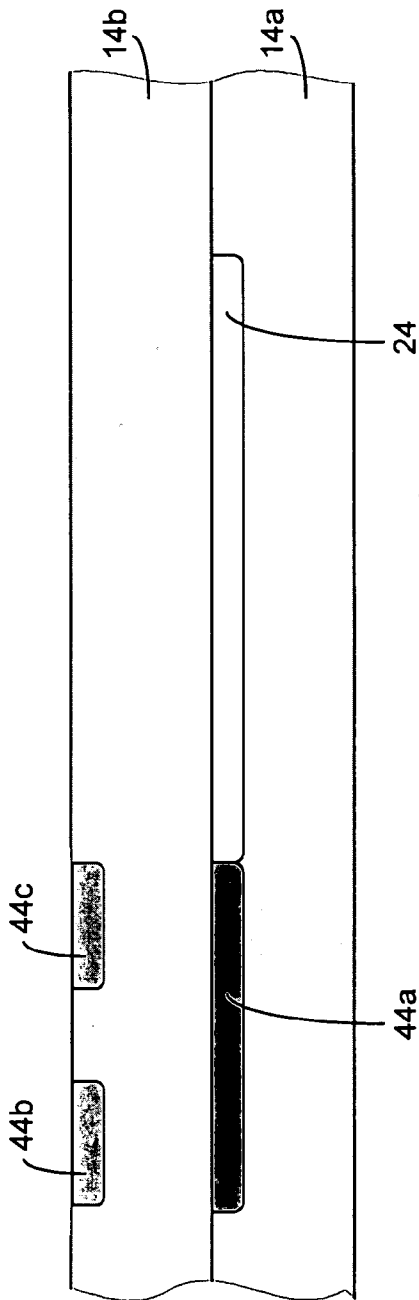

FIGURE 30C

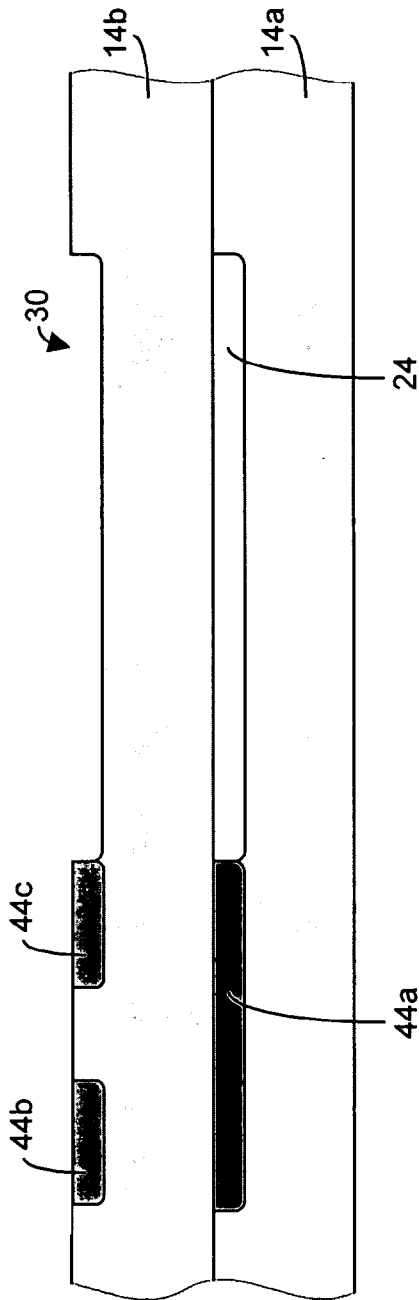

FIGURE 30D

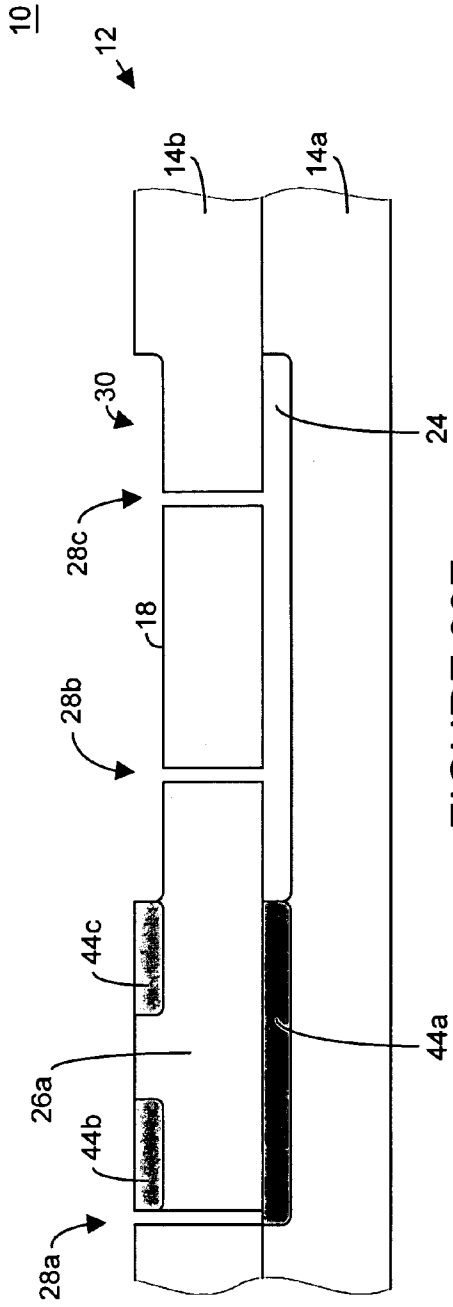

FIGURE 30E

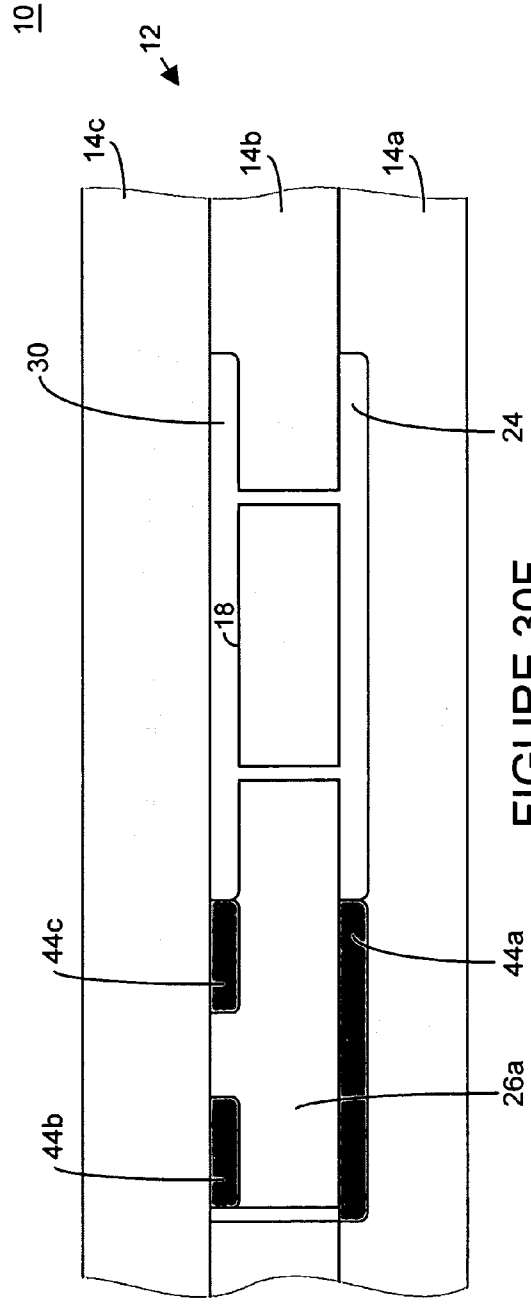

FIGURE 30F

10

12

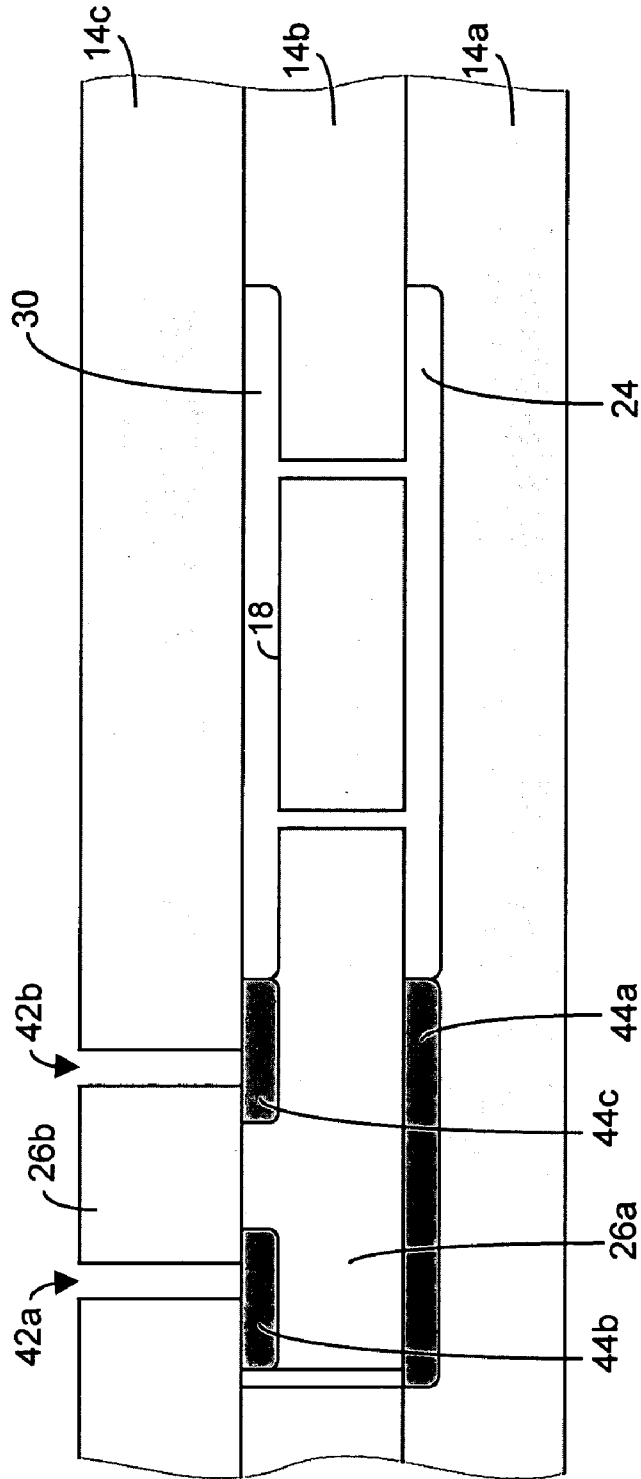

FIGURE 30G

10

12

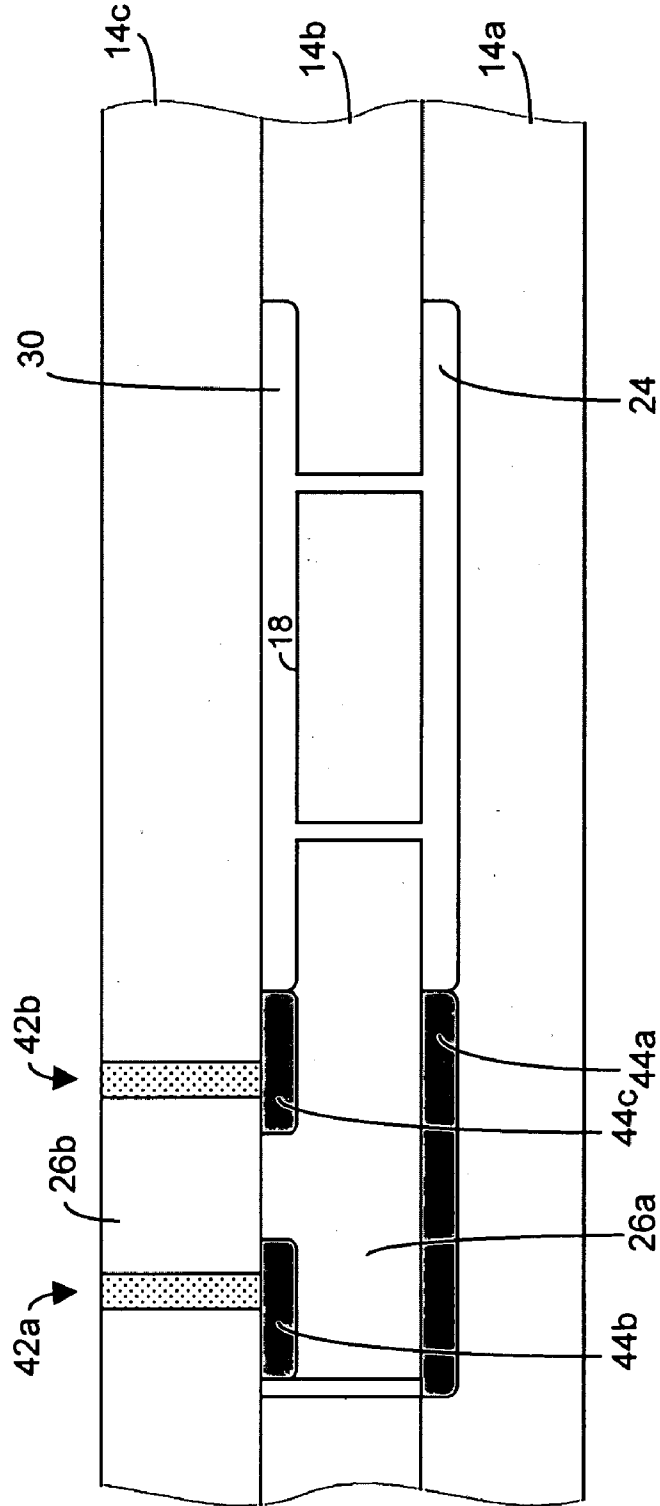

FIGURE 30H

10

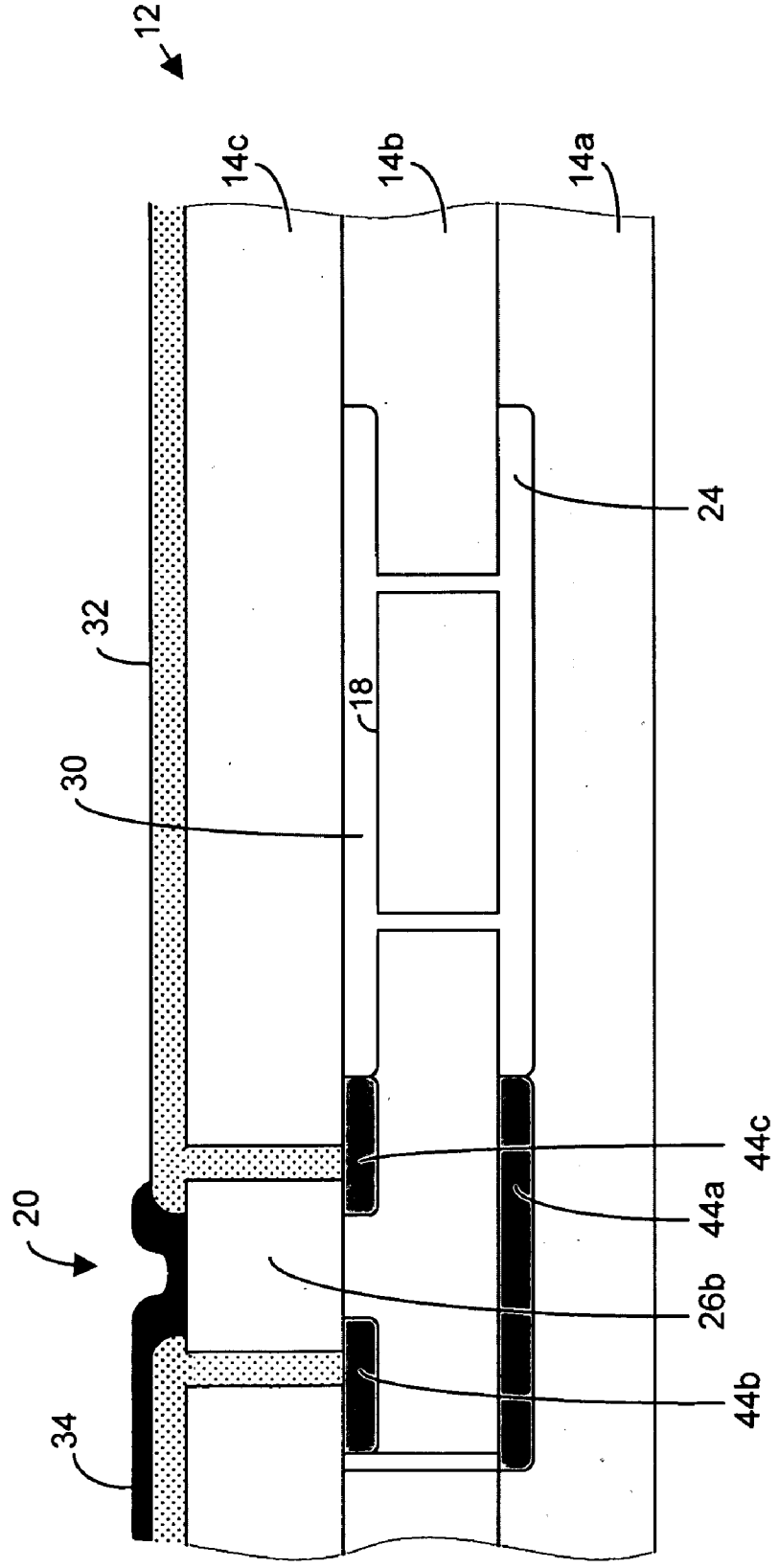

FIGURE 30I

10

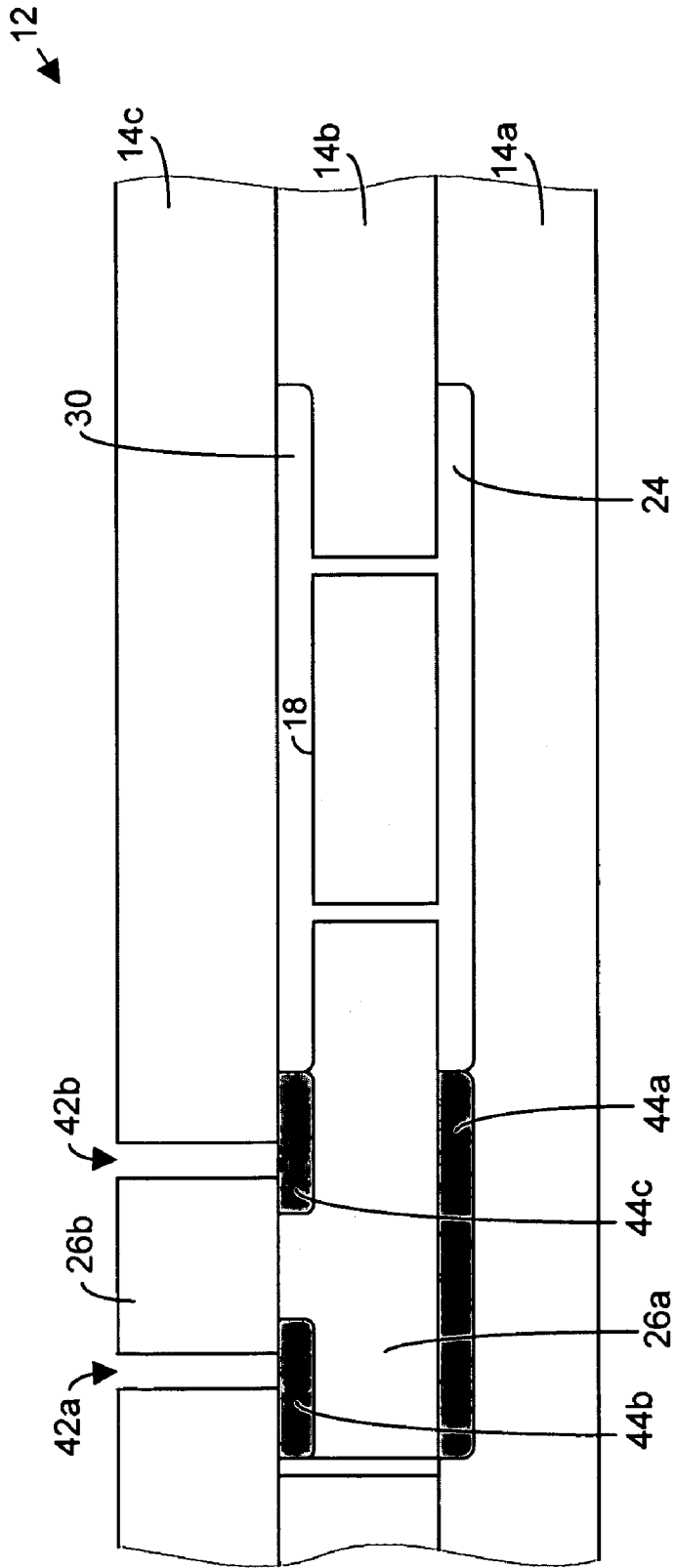

FIGURE 31A

10

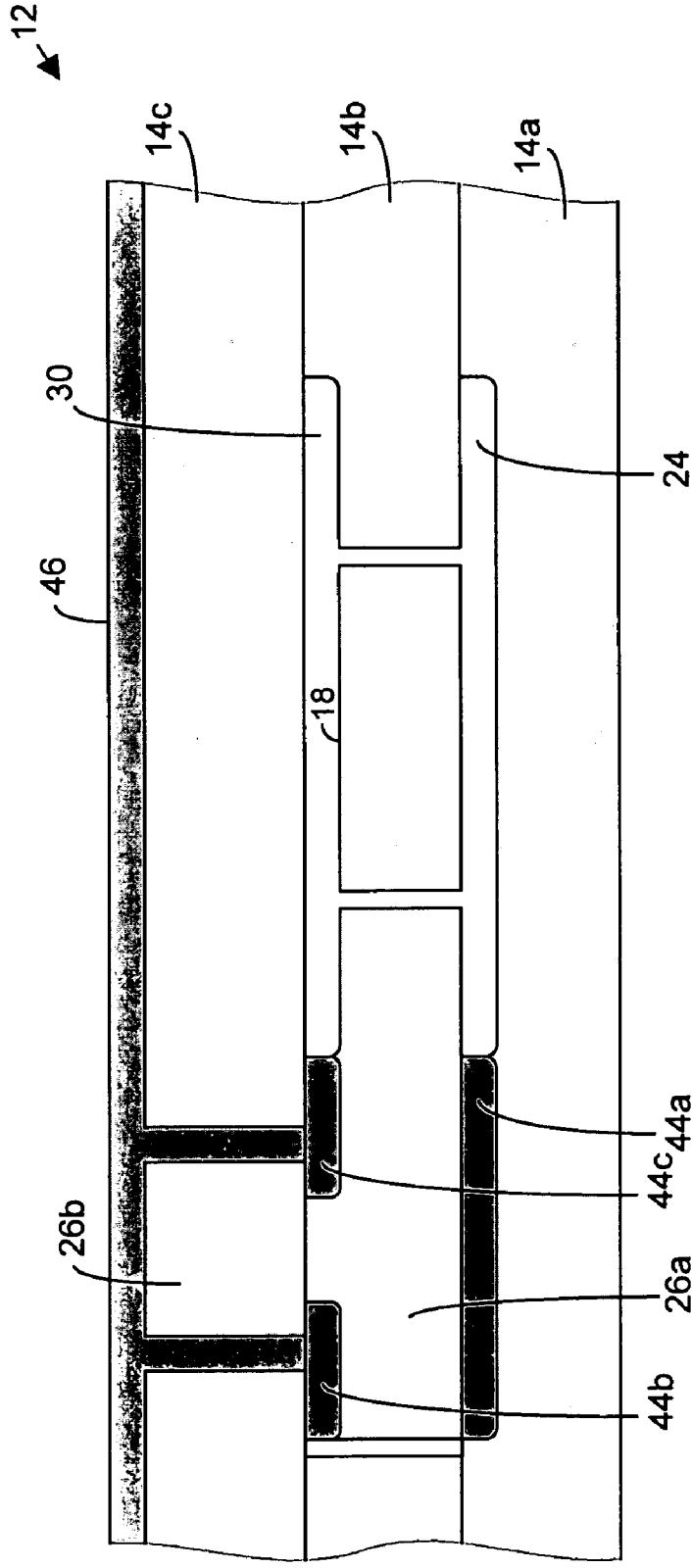

FIGURE 31B

10

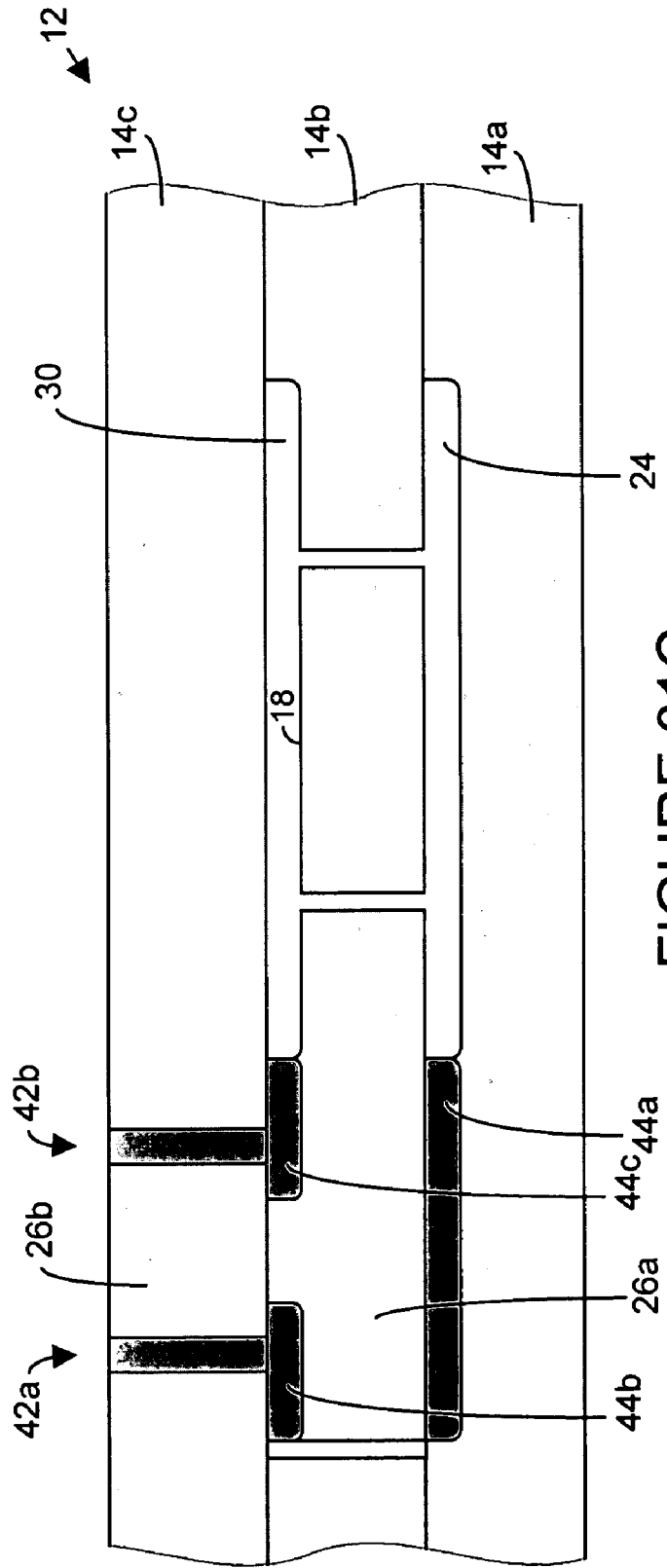

FIGURE 31C

10

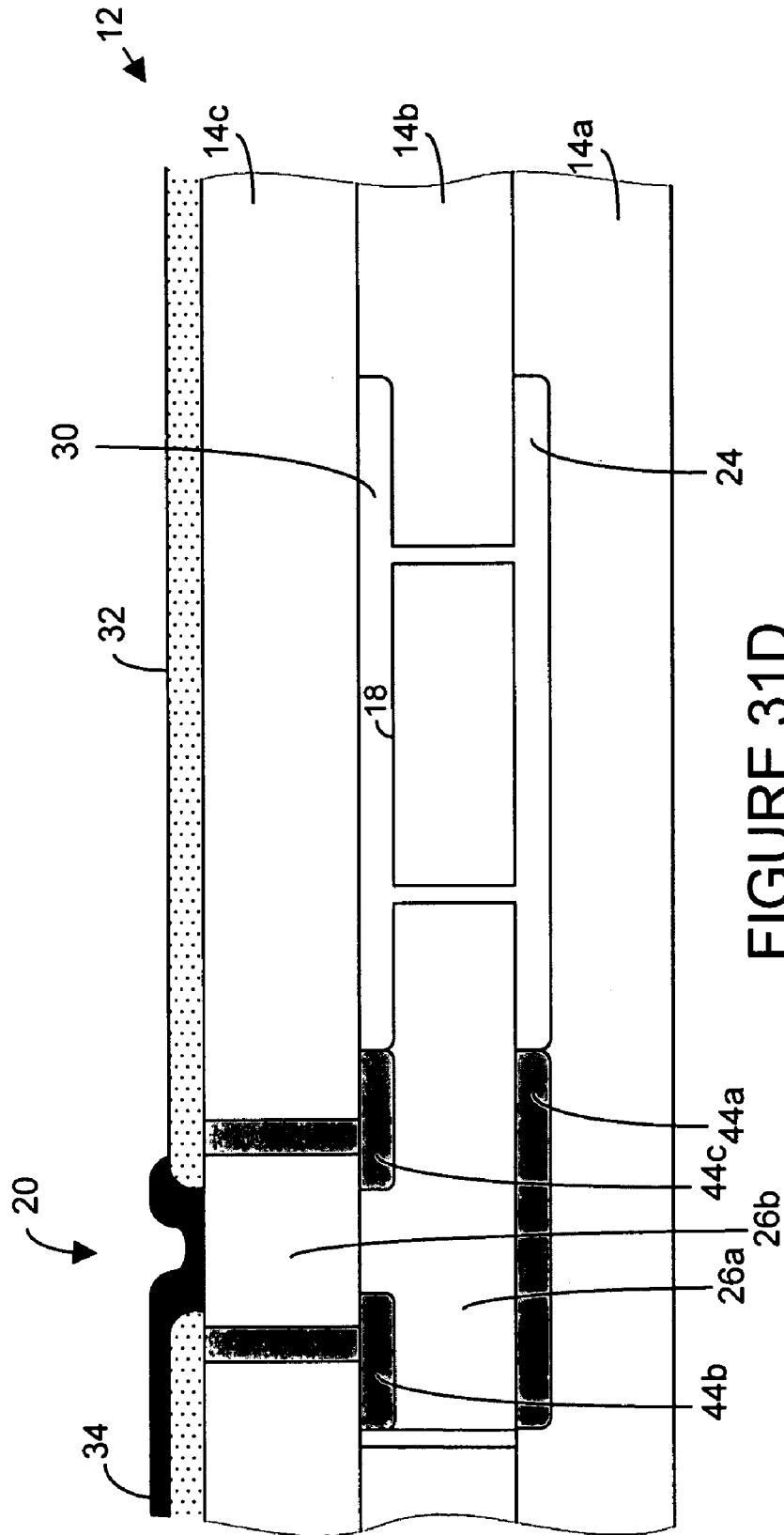

FIGURE 31D

10

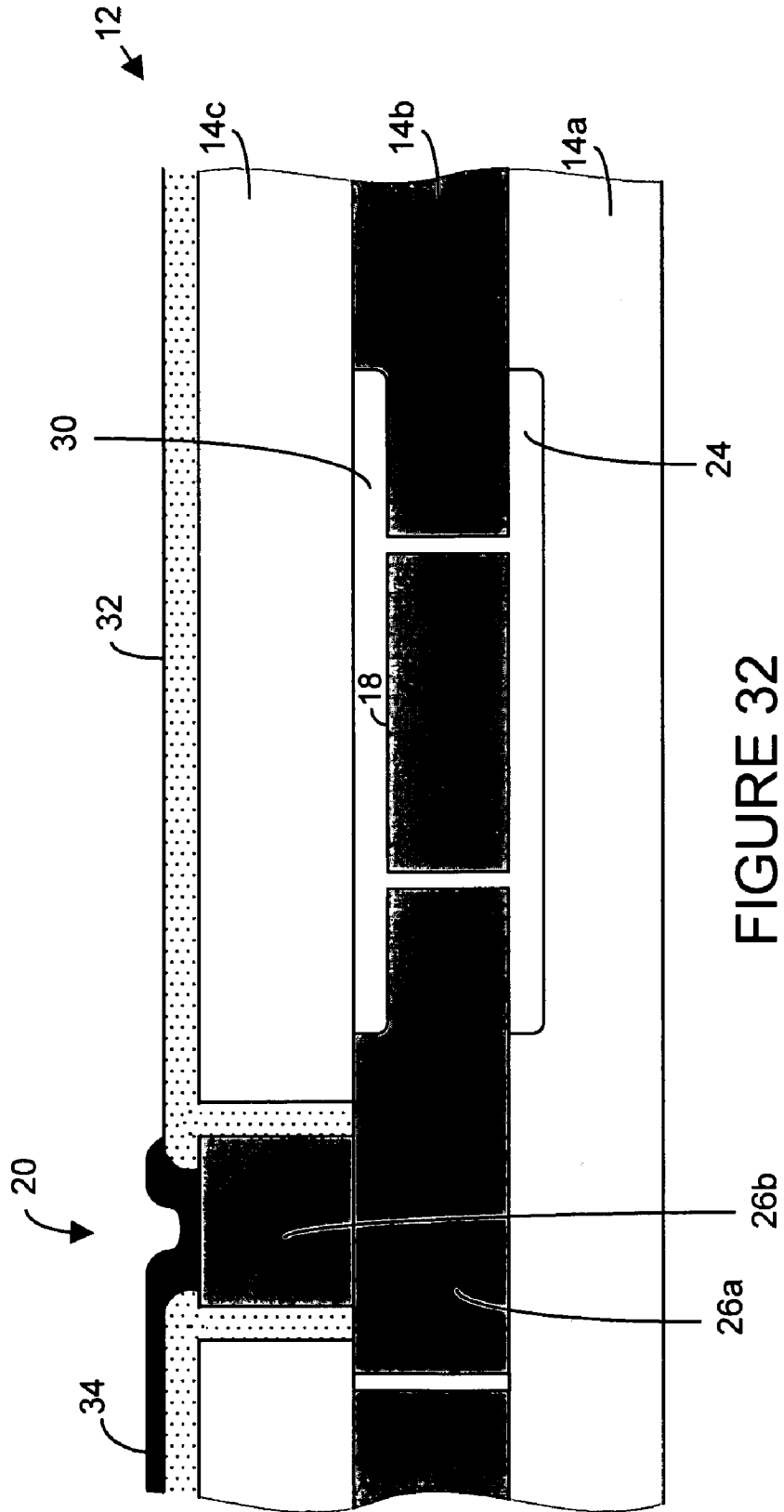

FIGURE 32

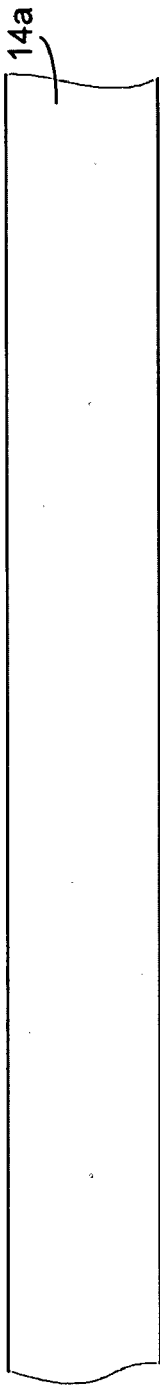

FIGURE 33A

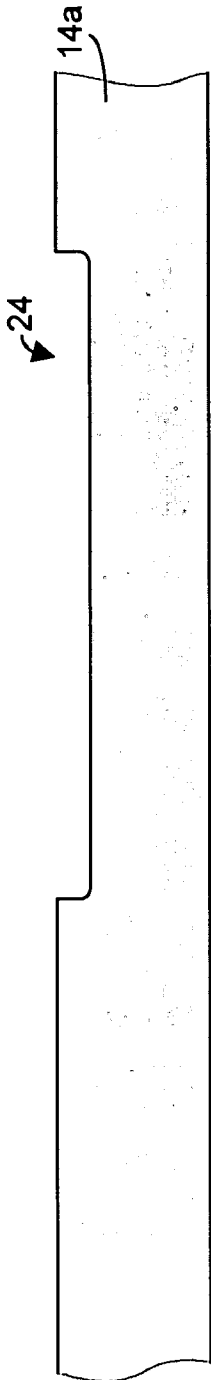

FIGURE 33B

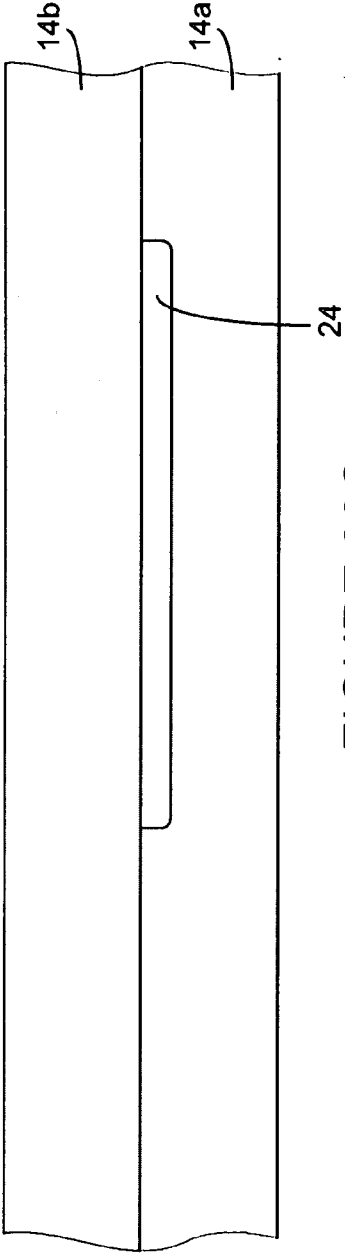

FIGURE 33C

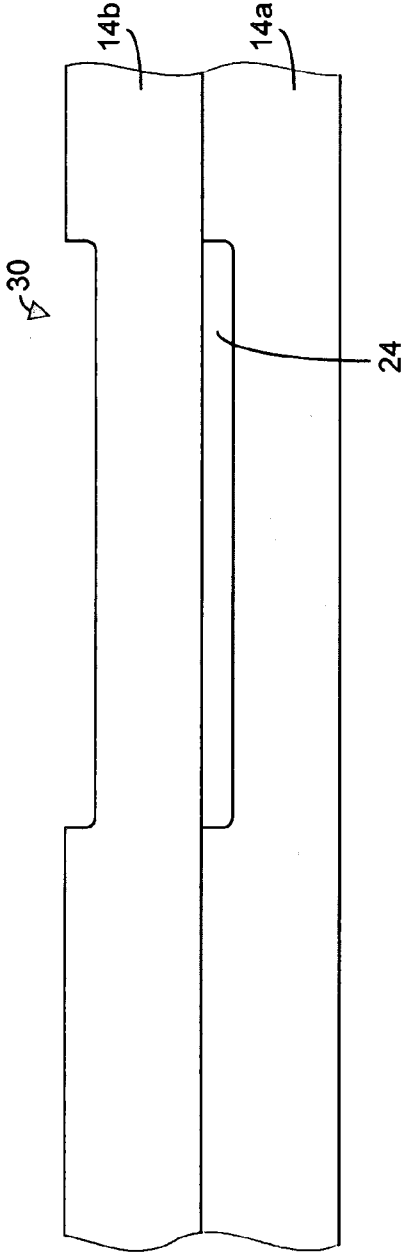
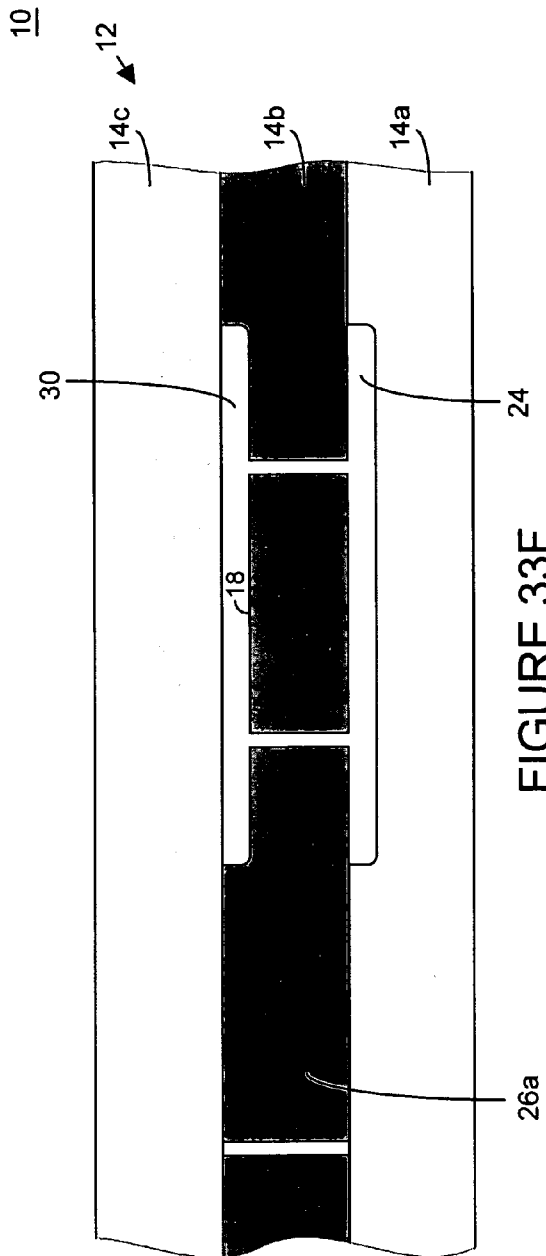
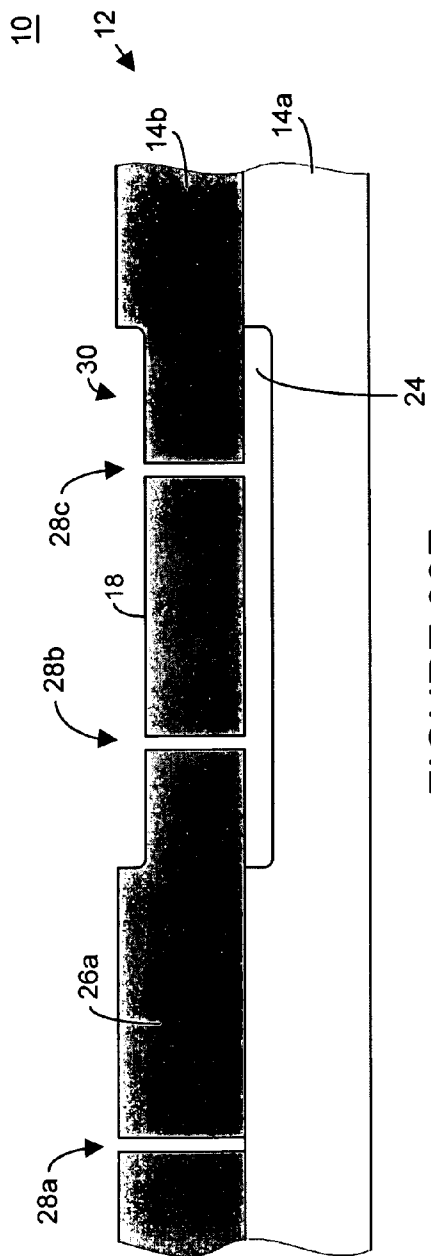

FIGURE 33D



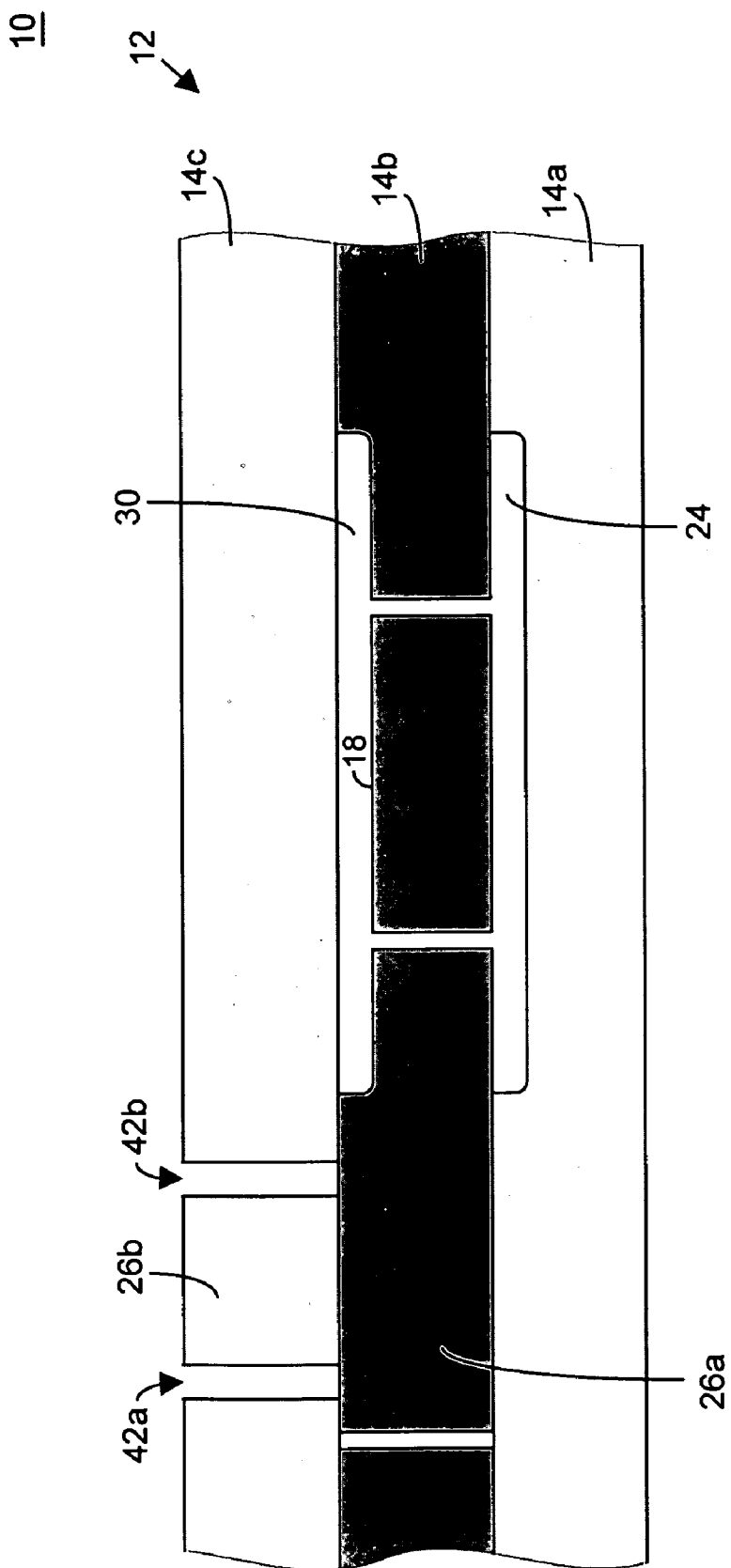

FIGURE 33G

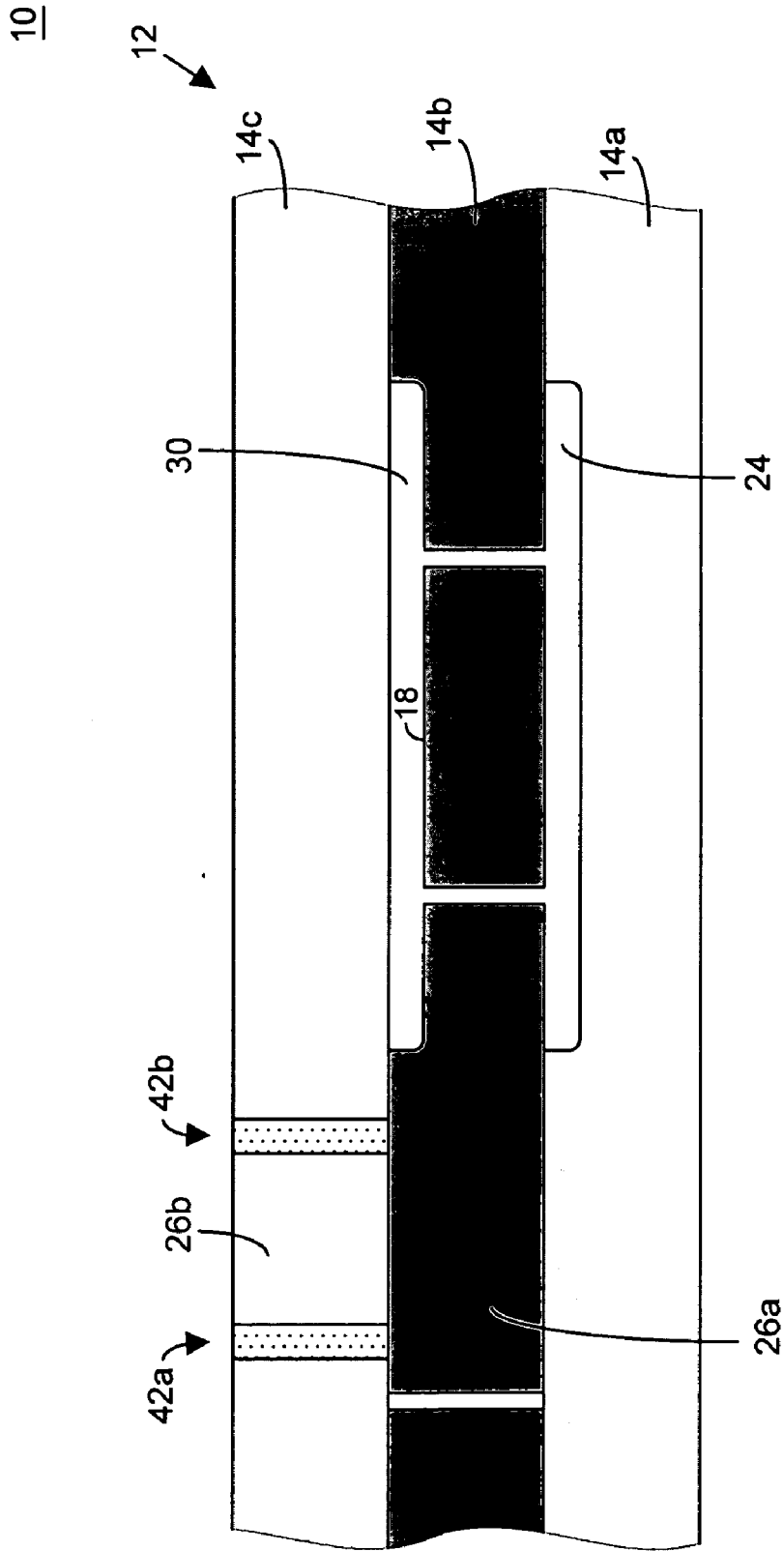

FIGURE 33H

10

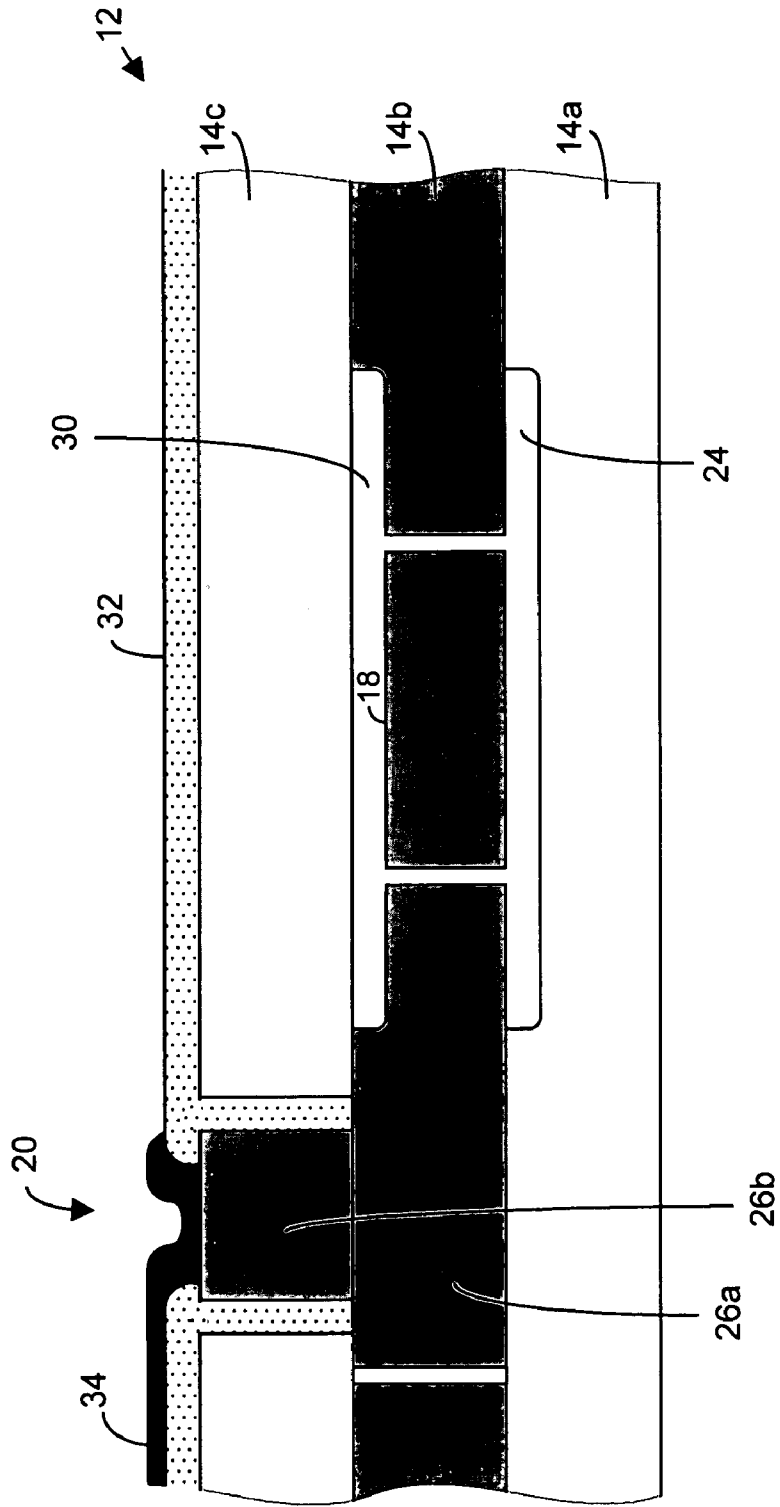

FIGURE 33I

10

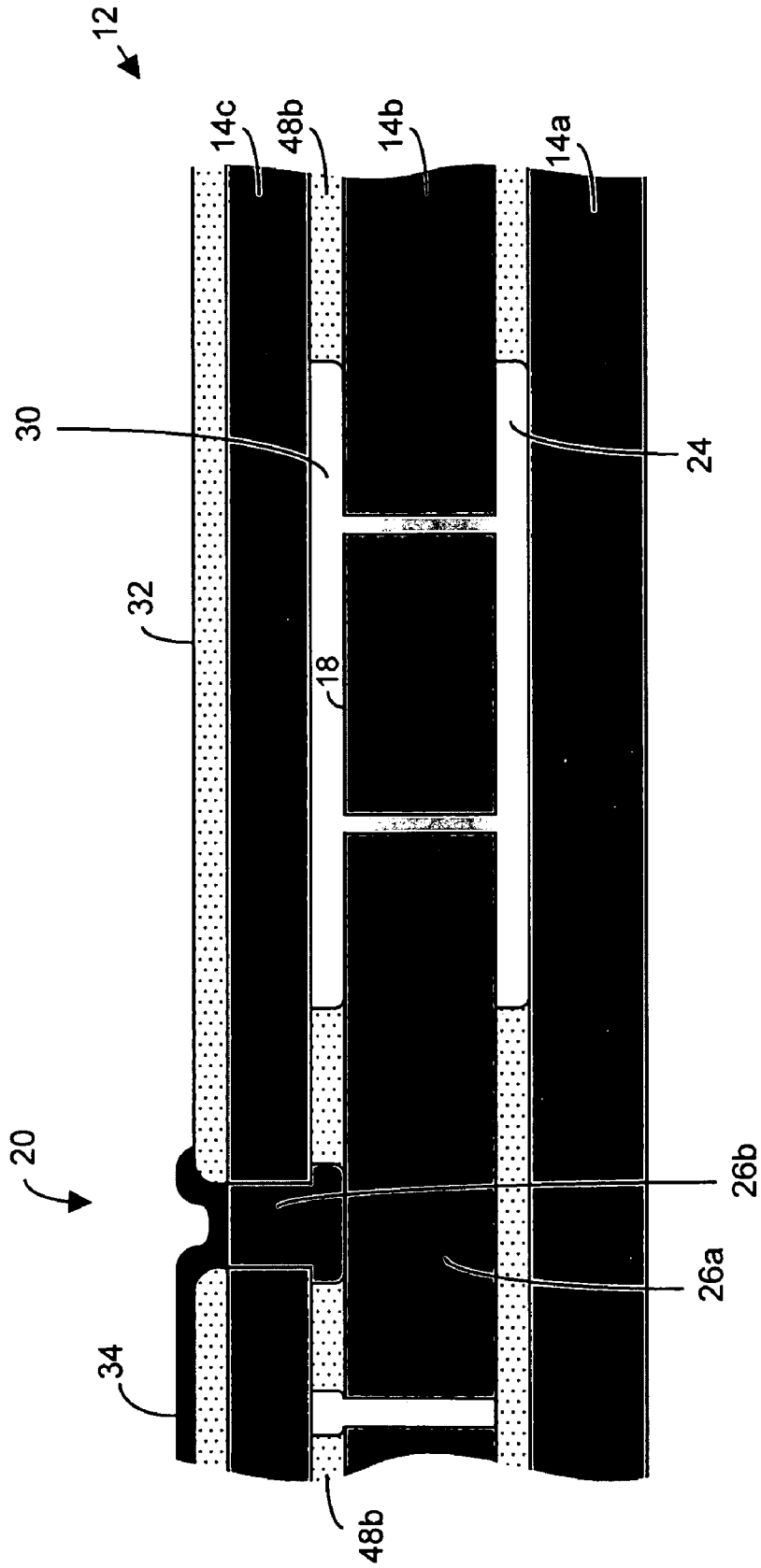

FIGURE 34

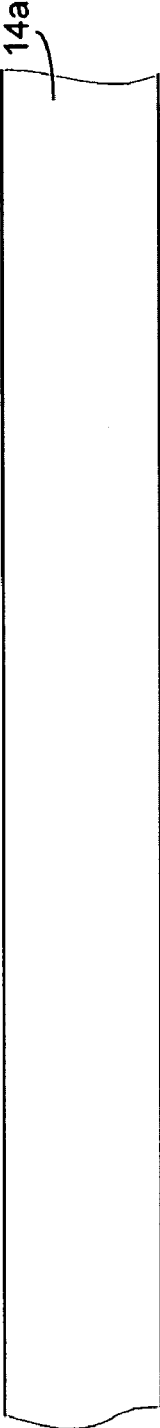

FIGURE 35A

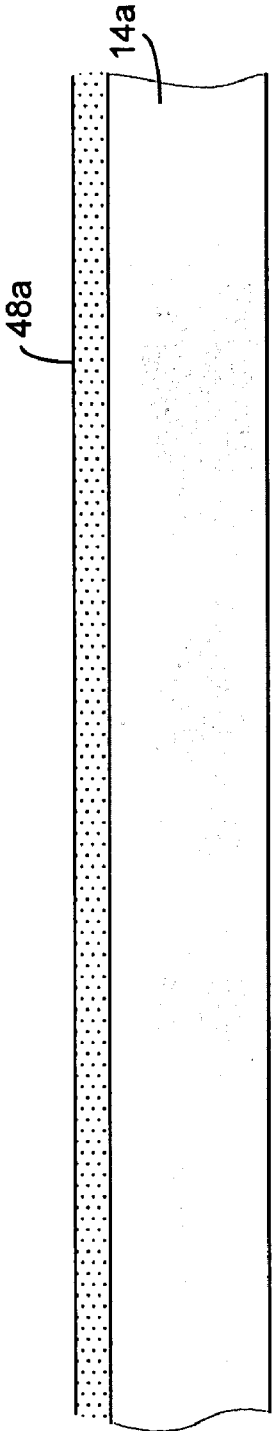

FIGURE 35B

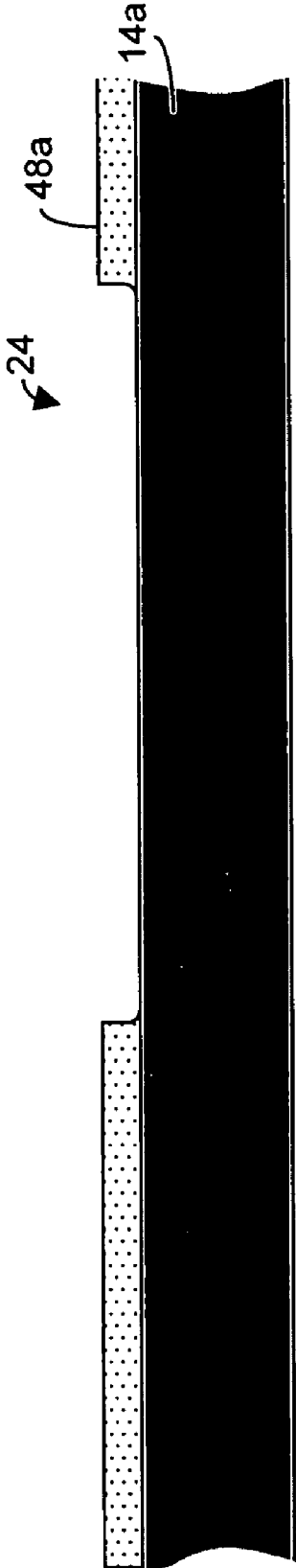

FIGURE 35C

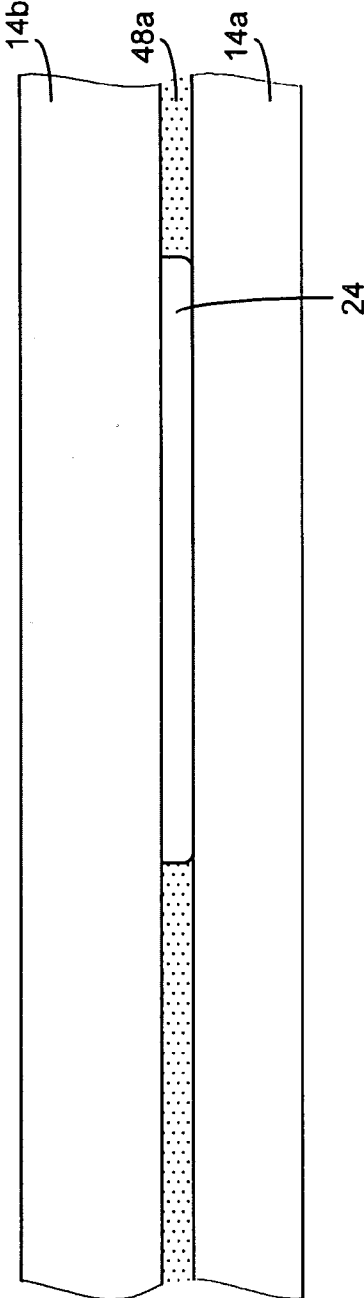

FIGURE 35D

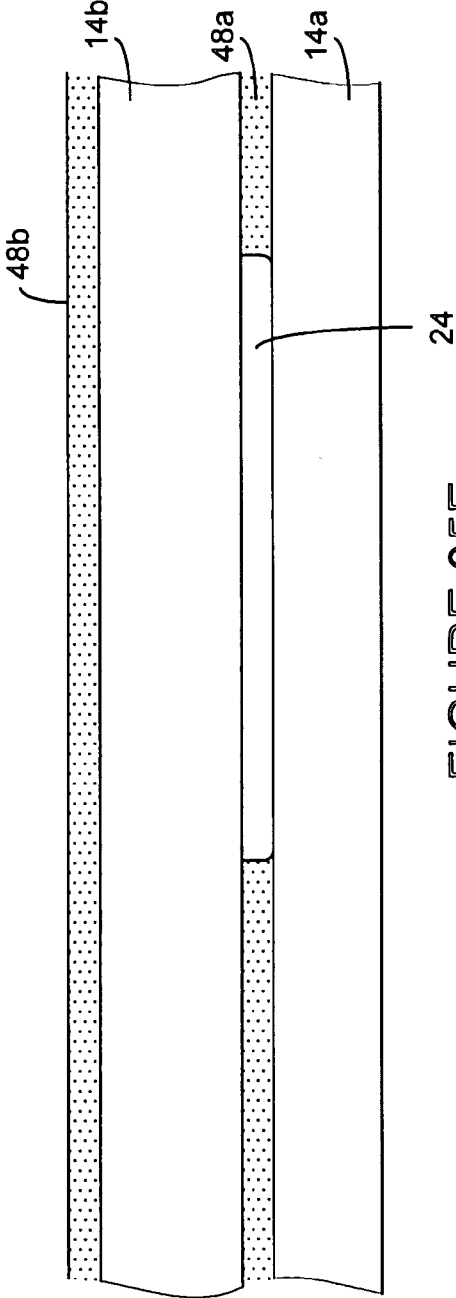

FIGURE 35E

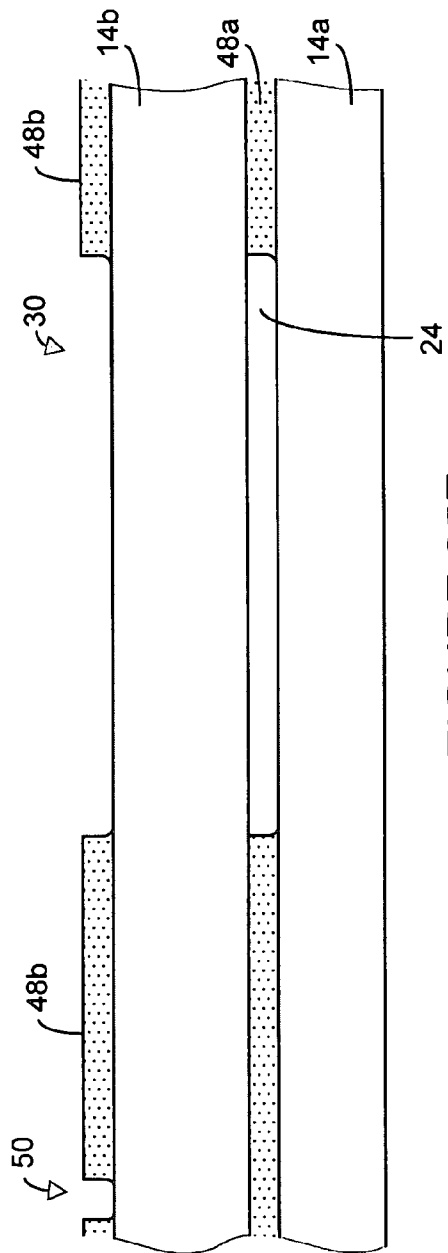

FIGURE 35F

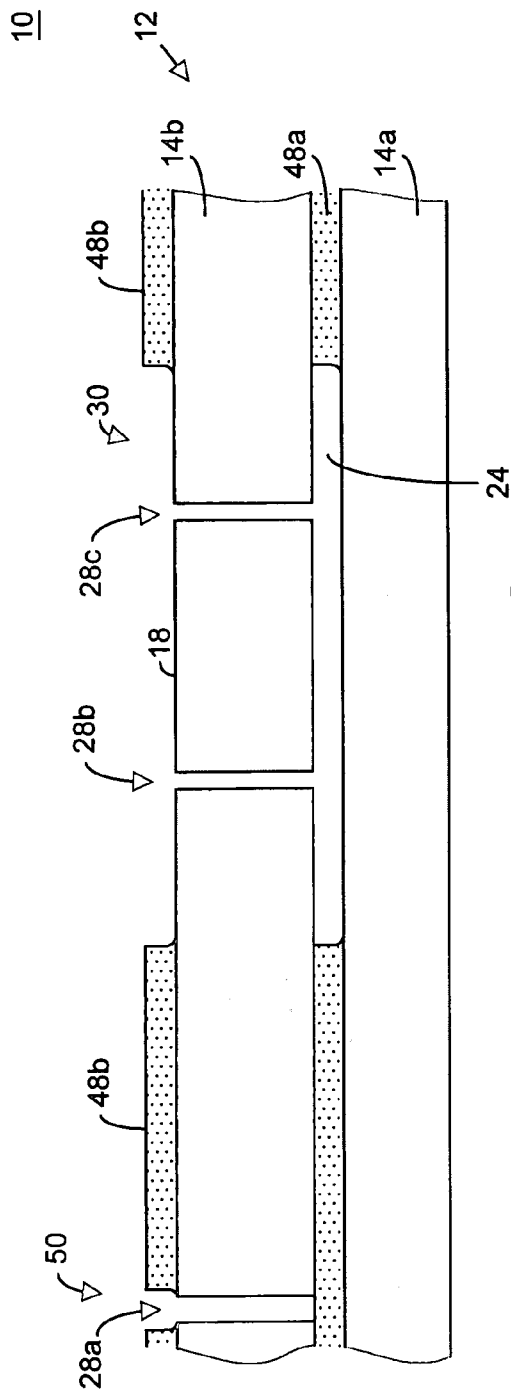
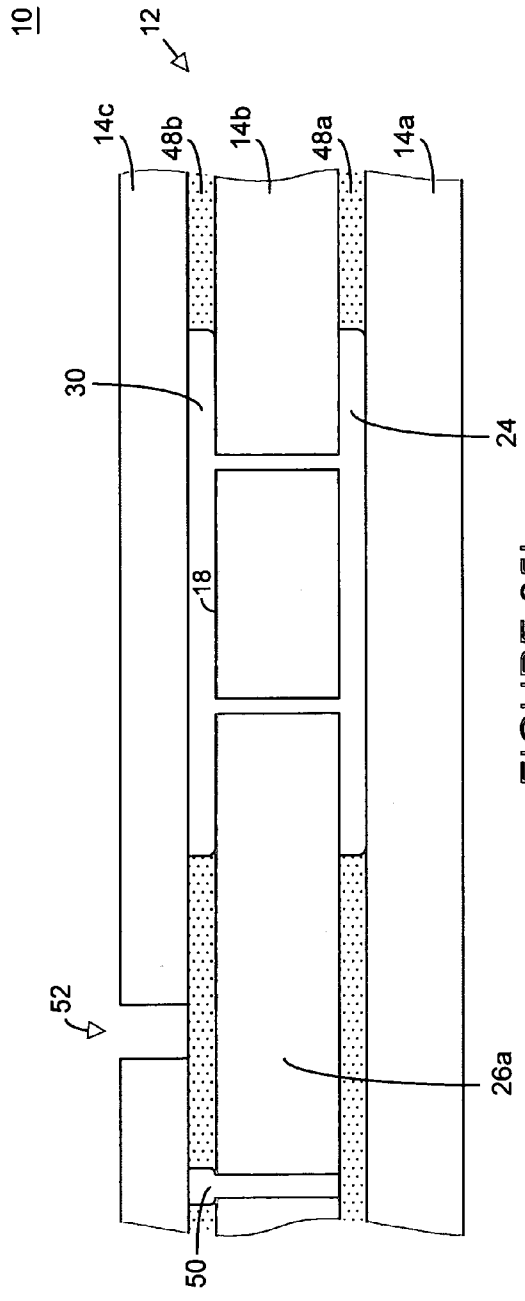
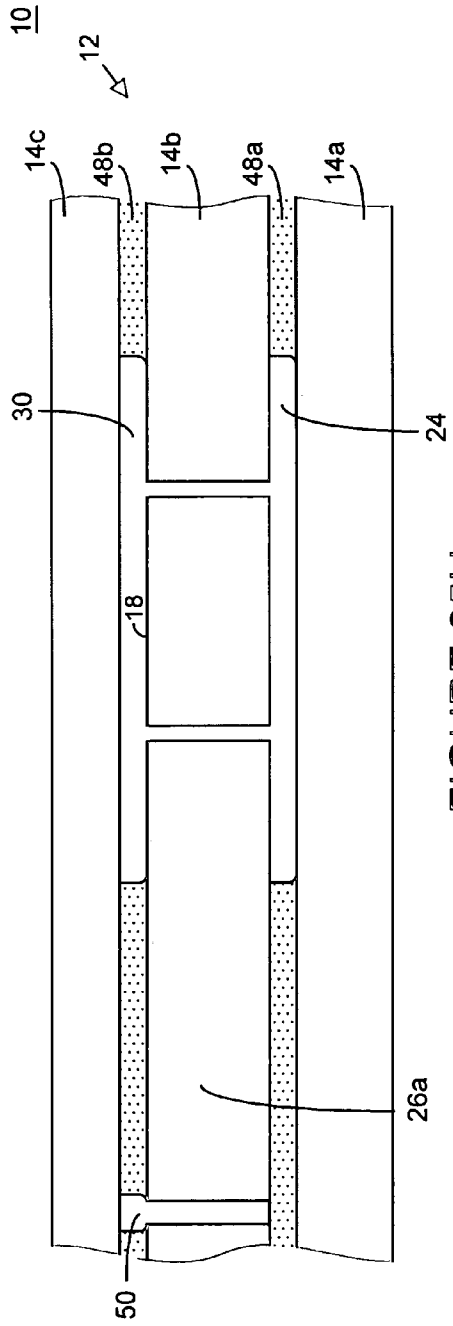

FIGURE 35G



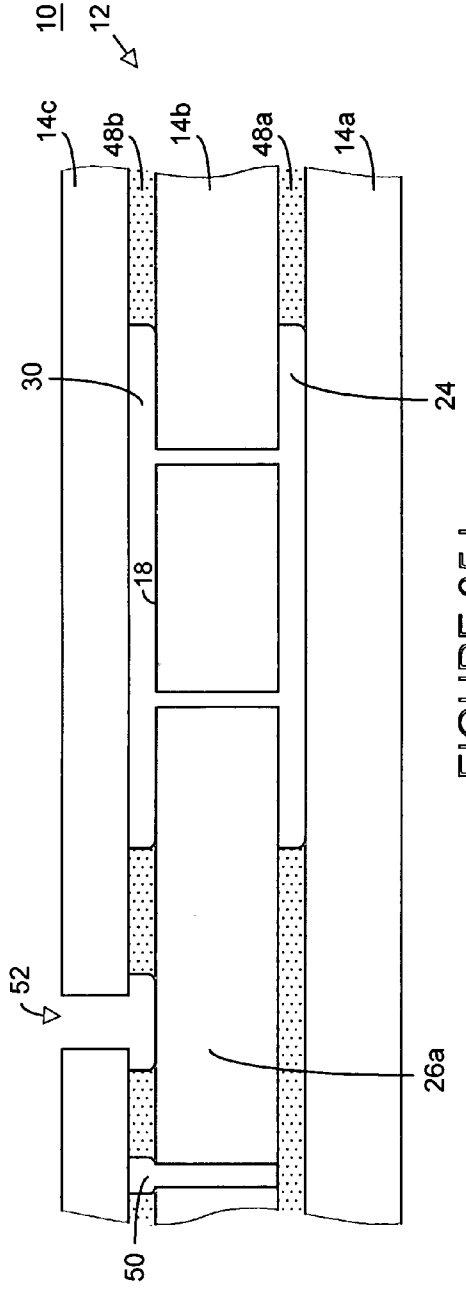

FIGURE 35J

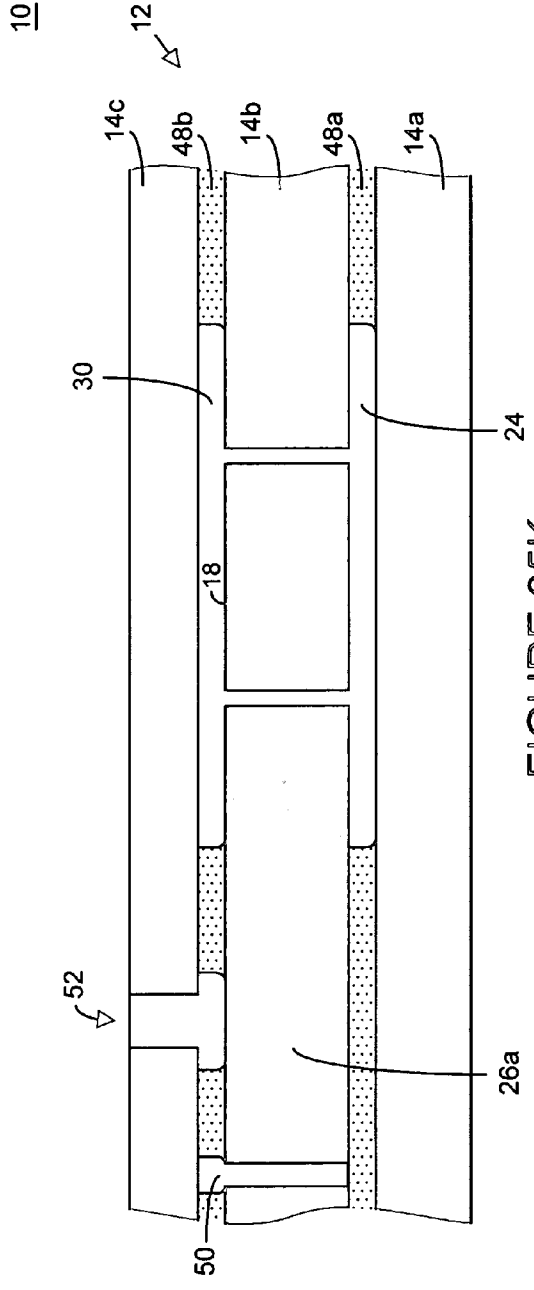

FIGURE 35K

10

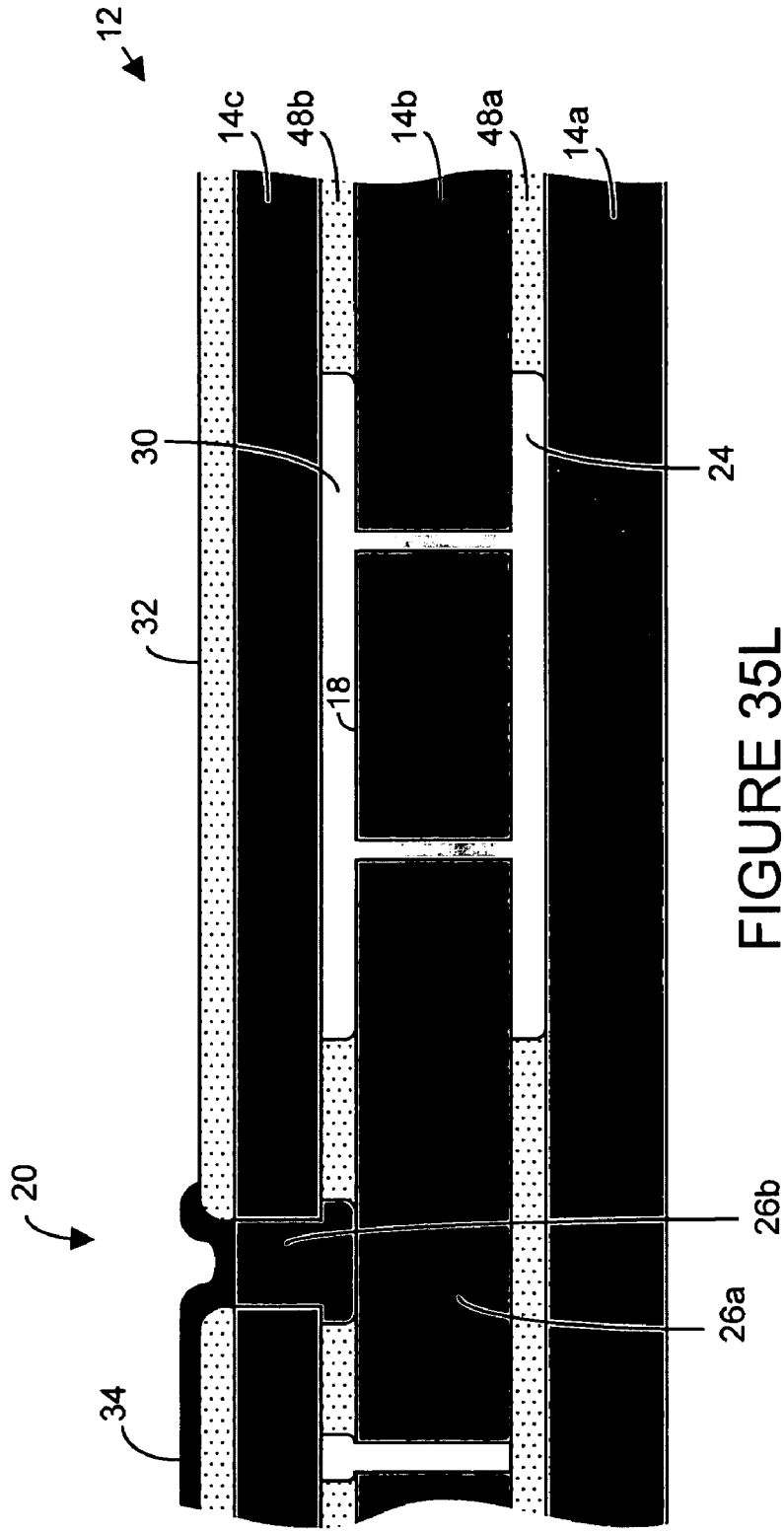

FIGURE 35L

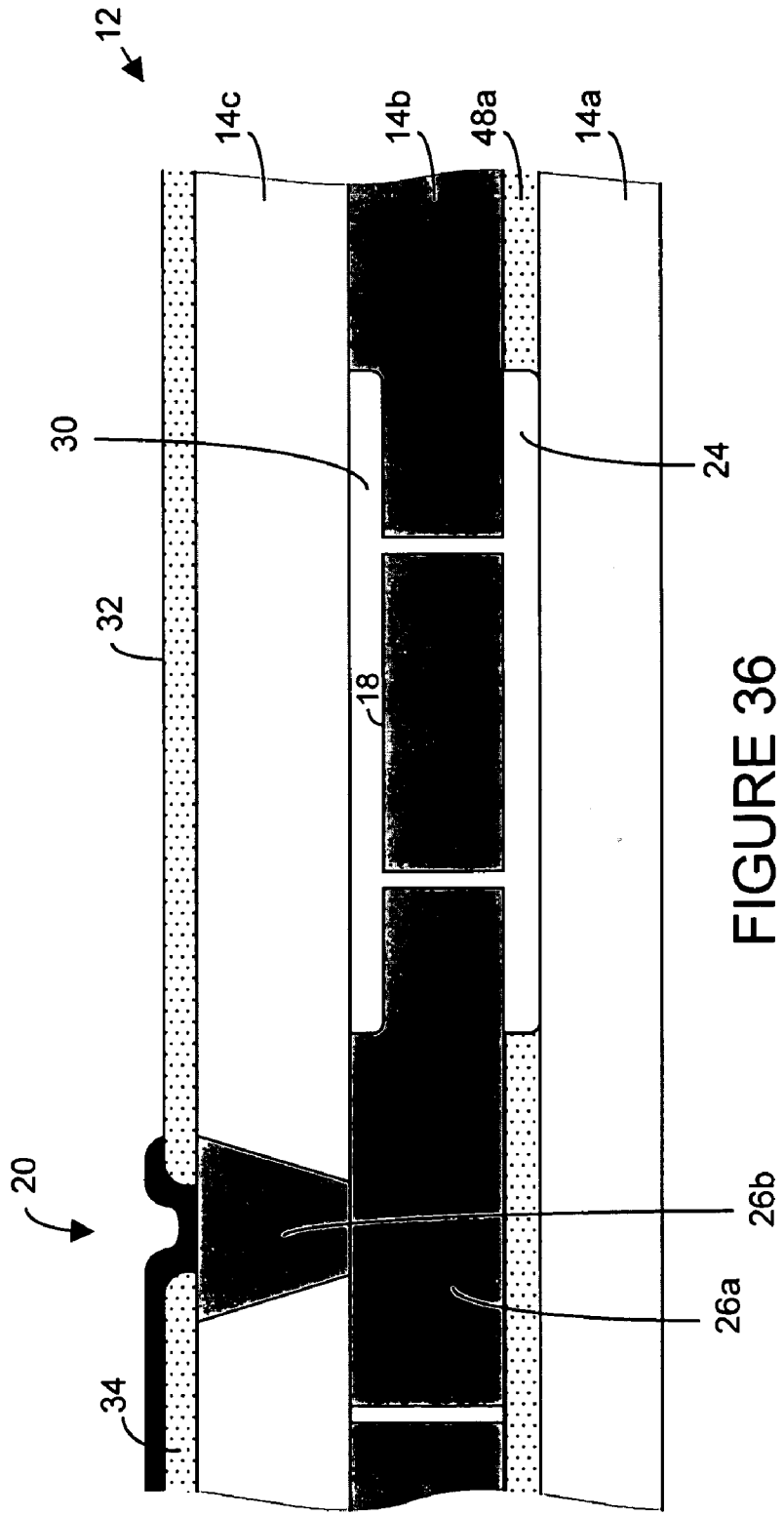

FIGURE 36



FIGURE 37A

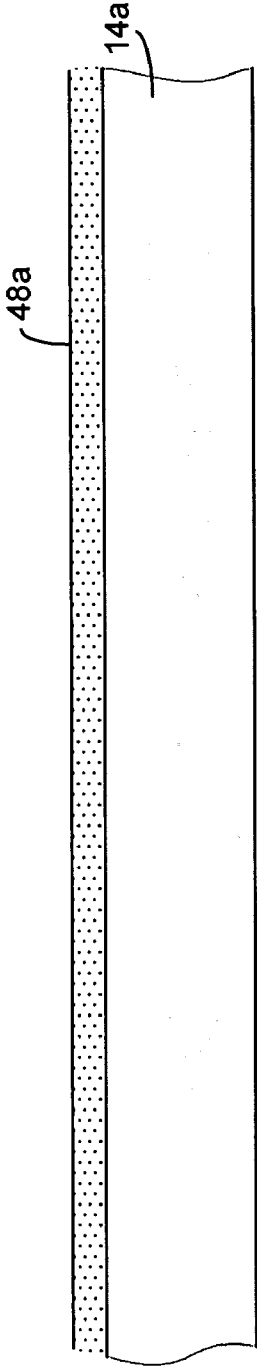

FIGURE 37B



FIGURE 37C

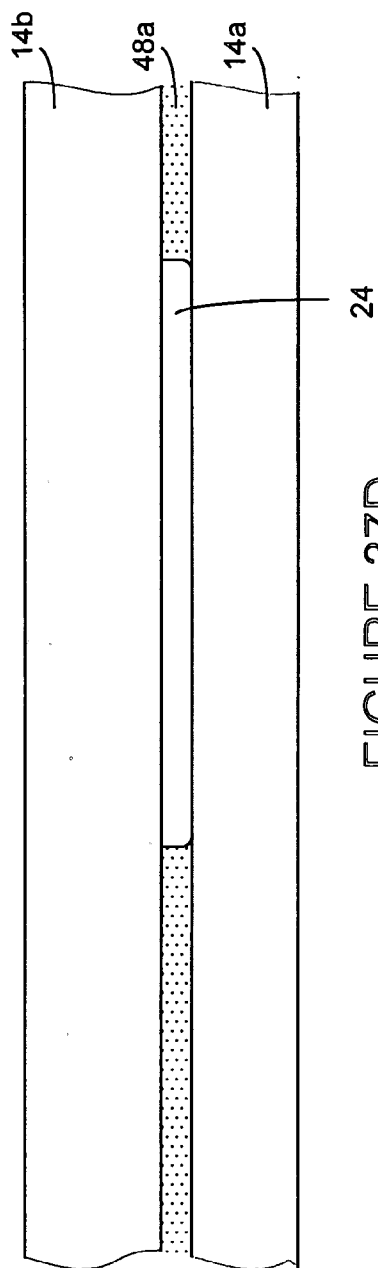

FIGURE 37D

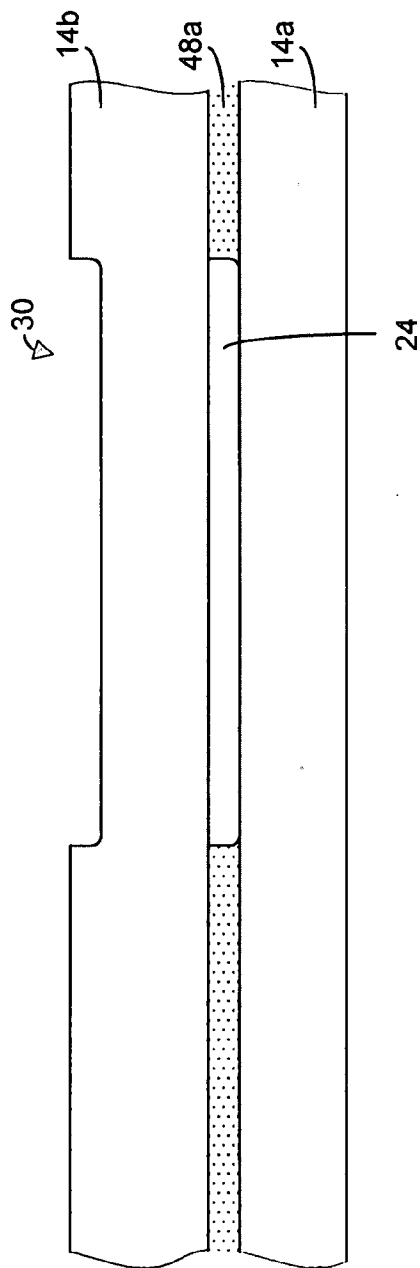

FIGURE 37E

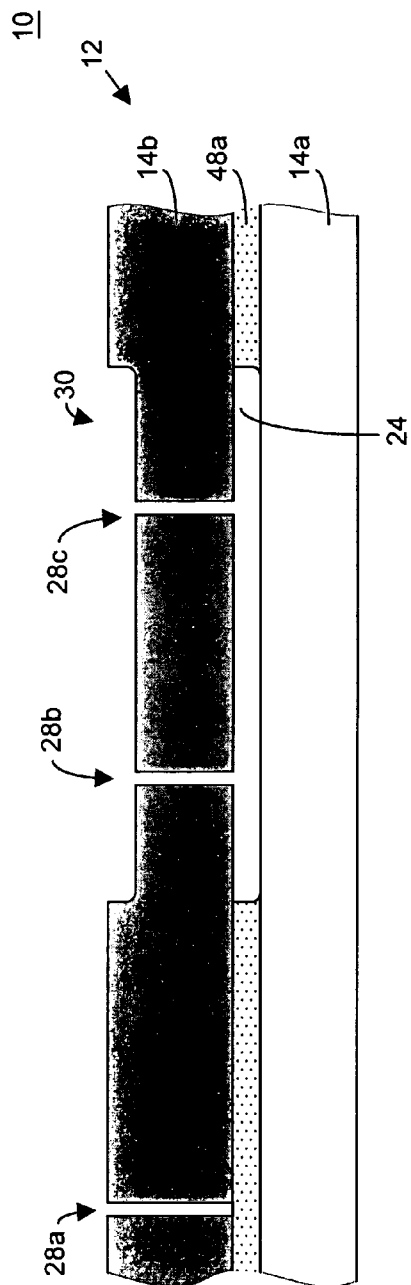

FIGURE 37F

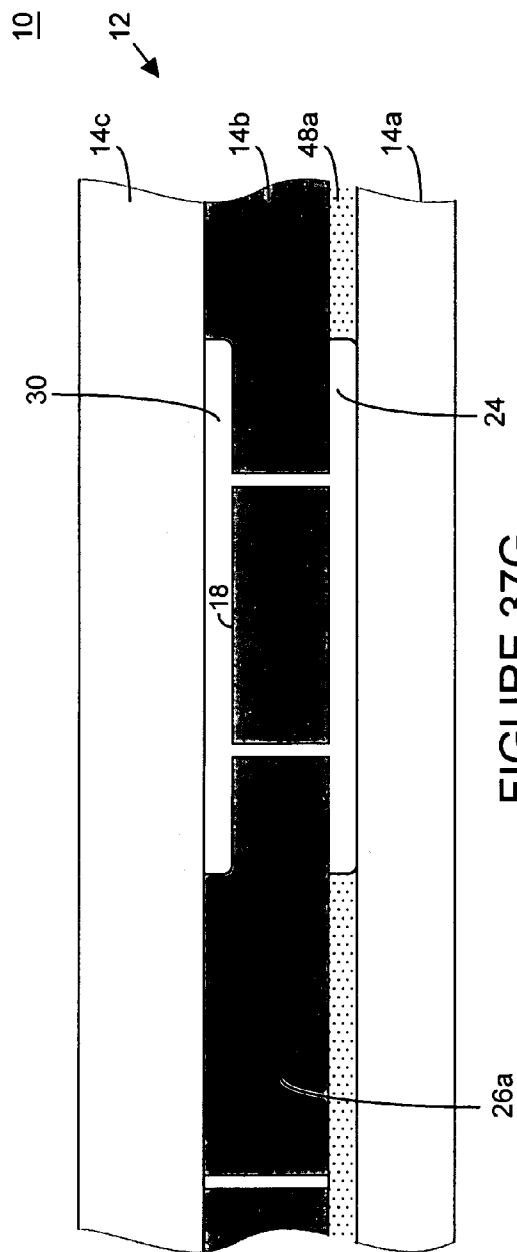

FIGURE 37G

10

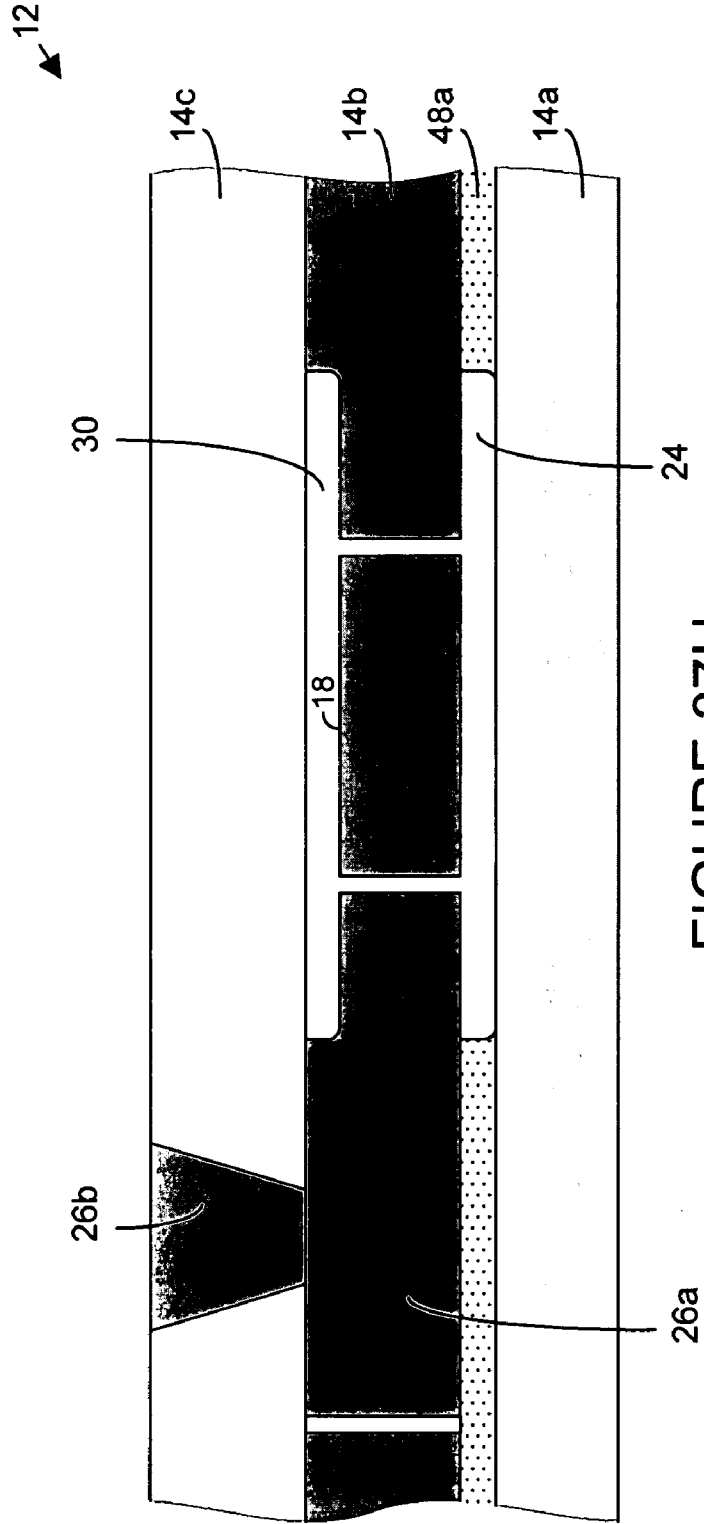

FIGURE 37H

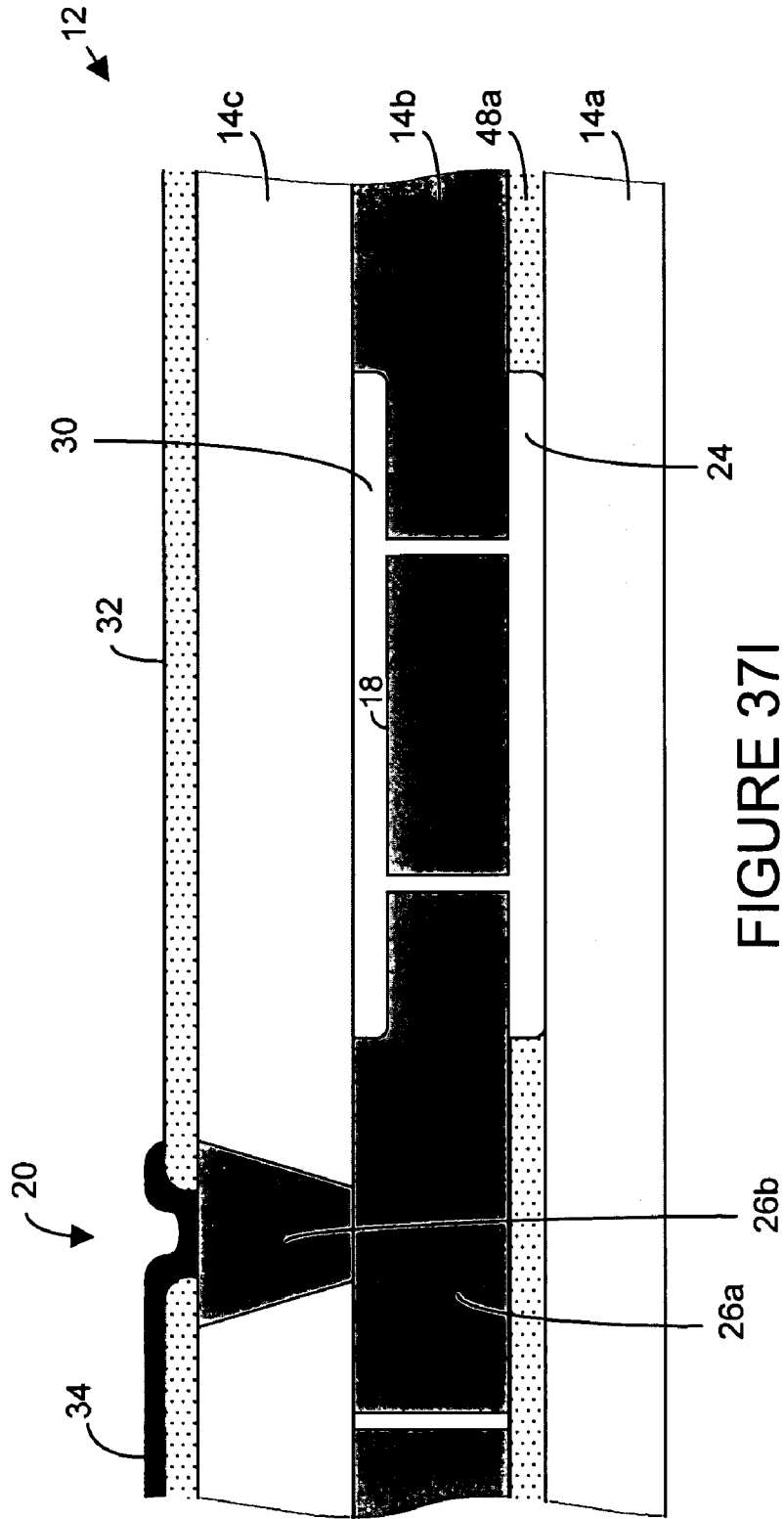

FIGURE 37I

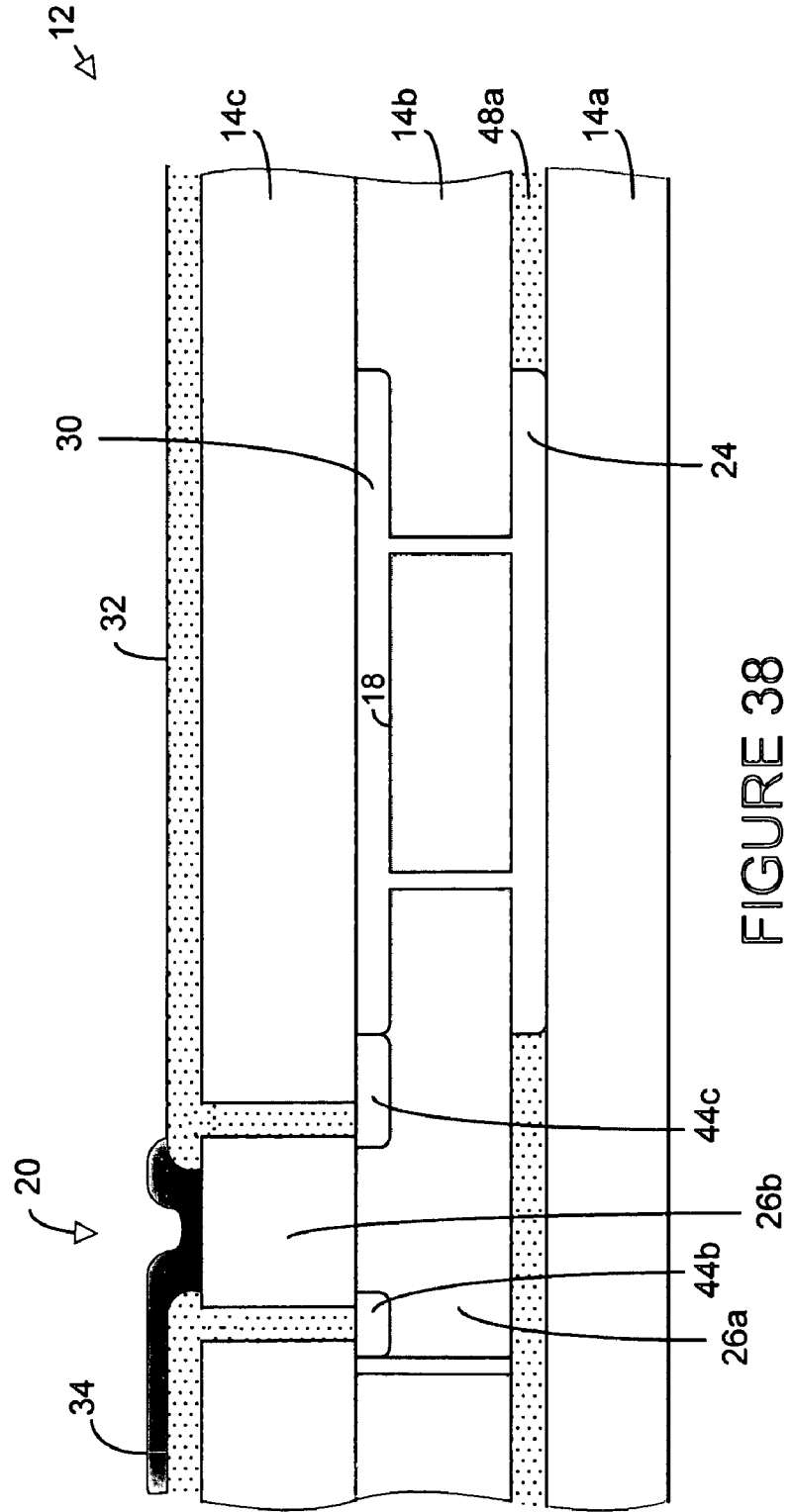

FIGURE 38

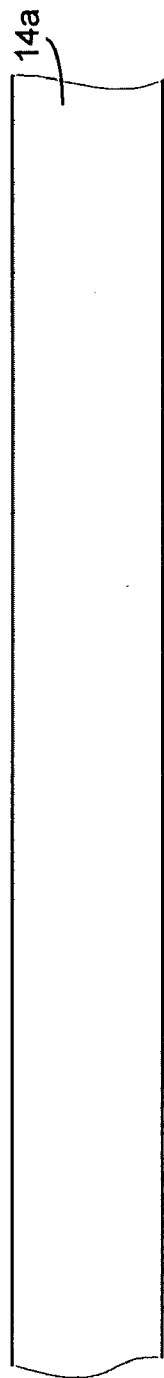

FIGURE 39A

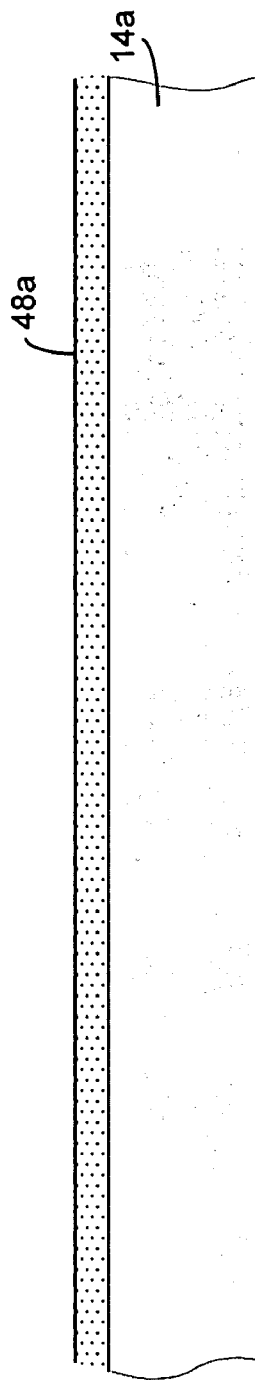

FIGURE 39B

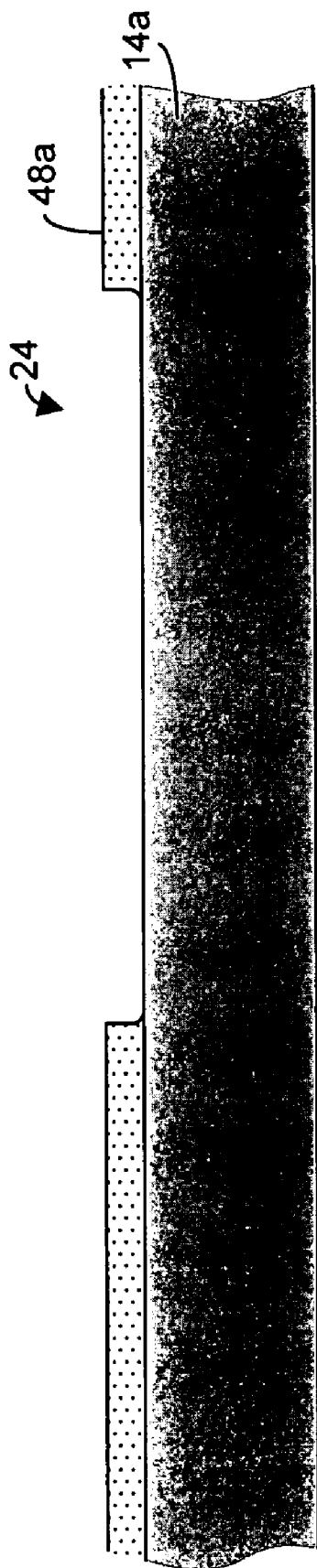

FIGURE 39C

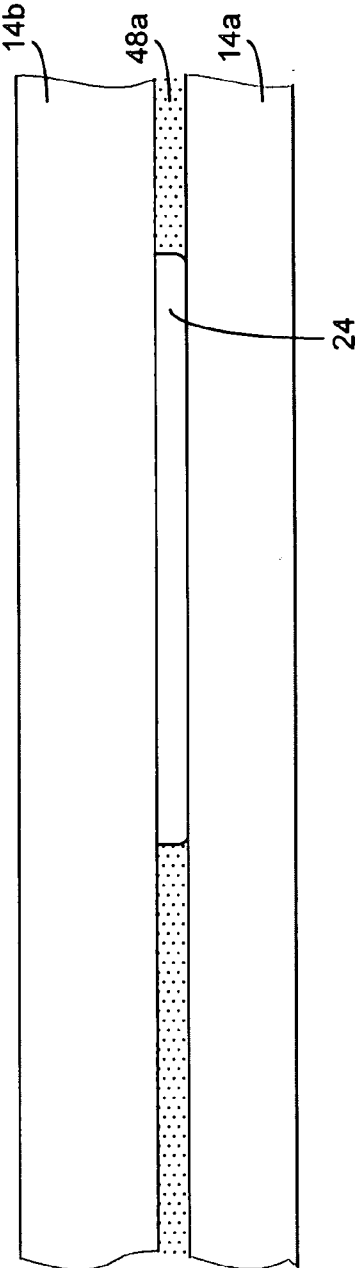

FIGURE 39D

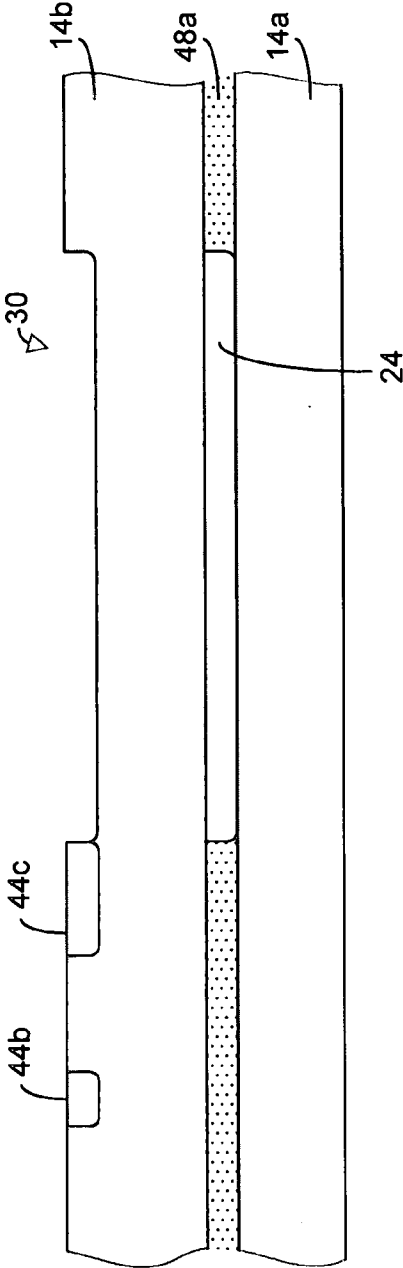
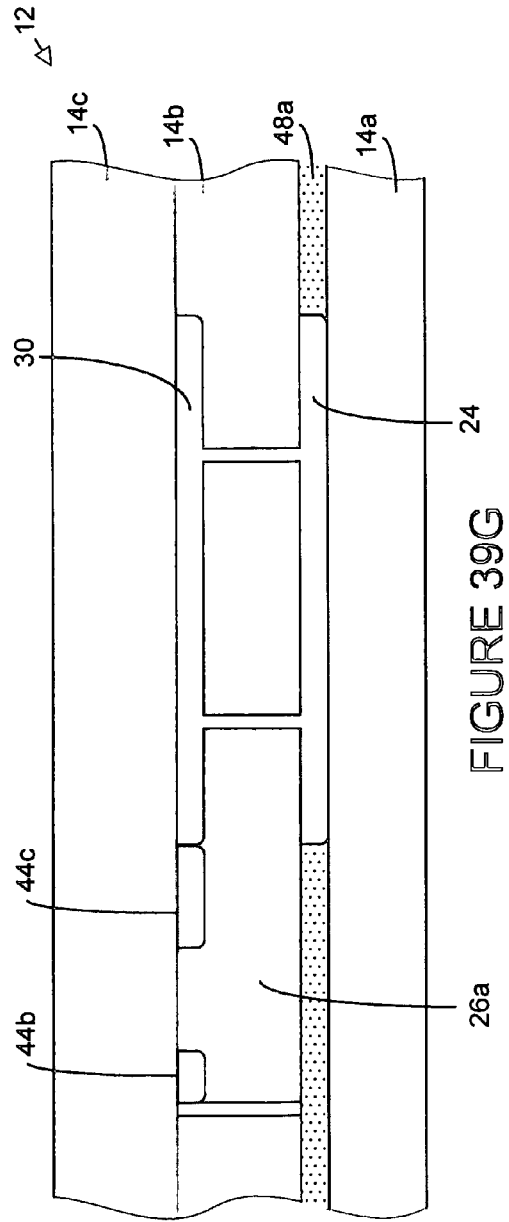
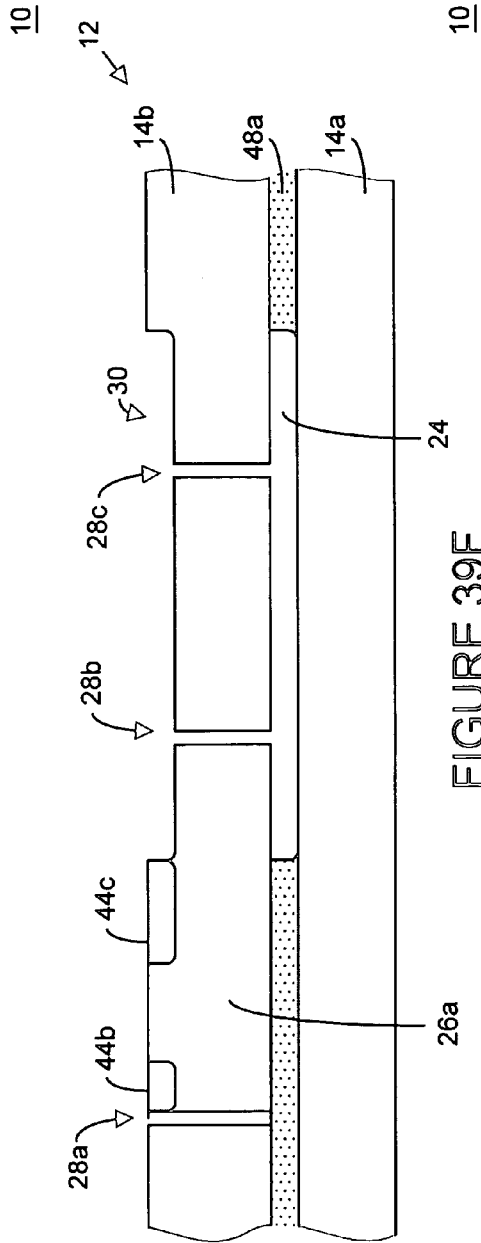

FIGURE 39E



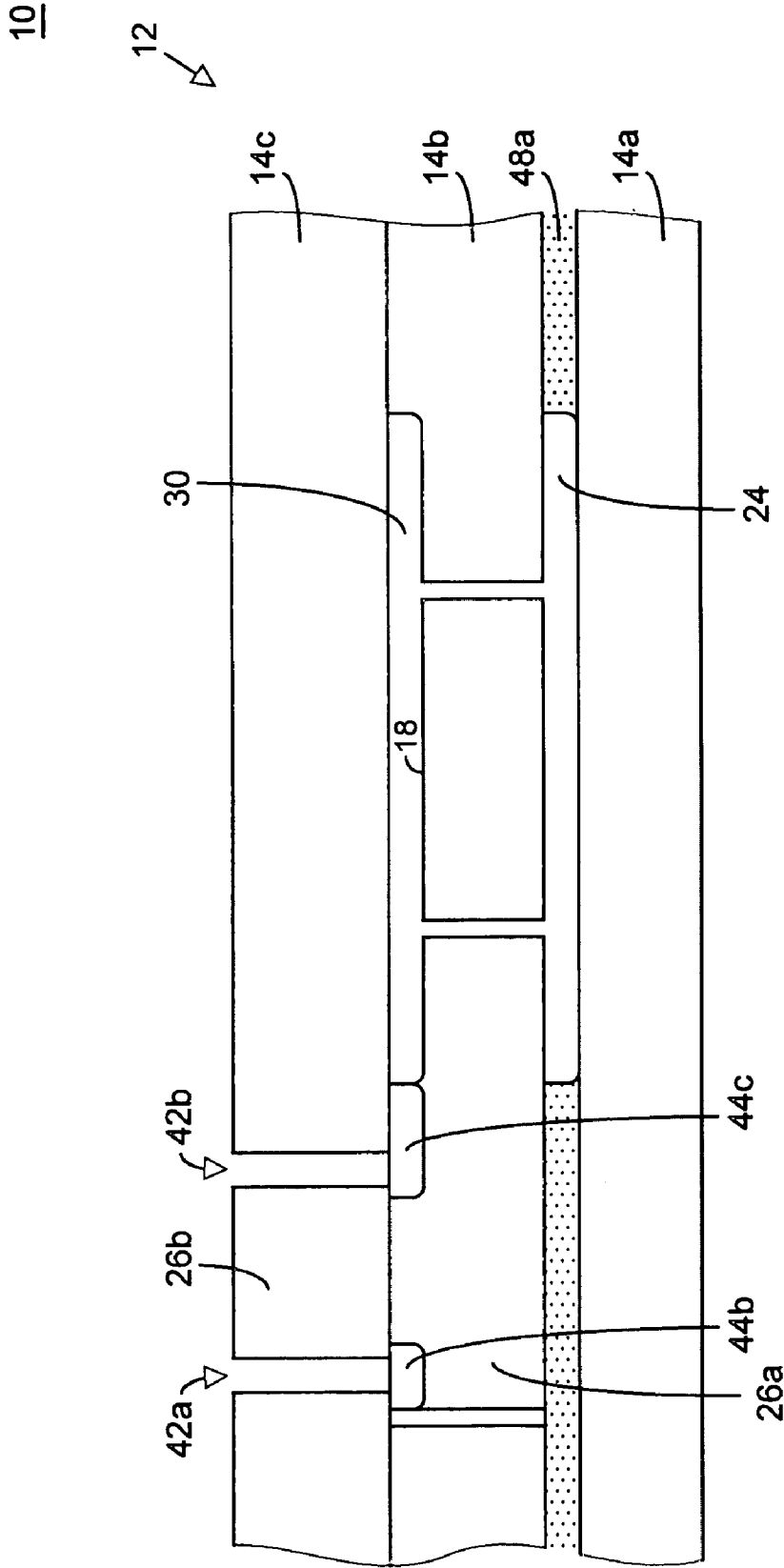

FIGURE 39H

10

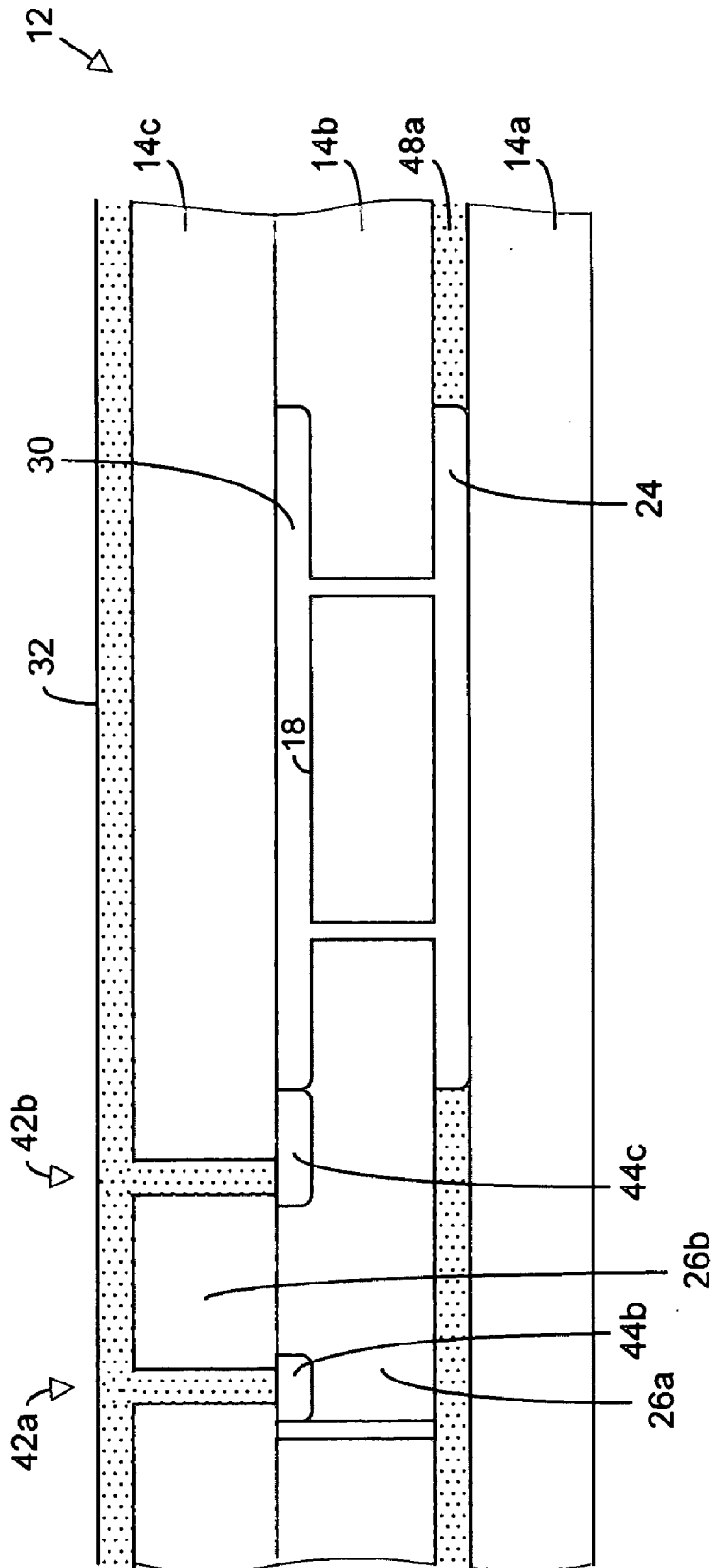

FIGURE 39I

10

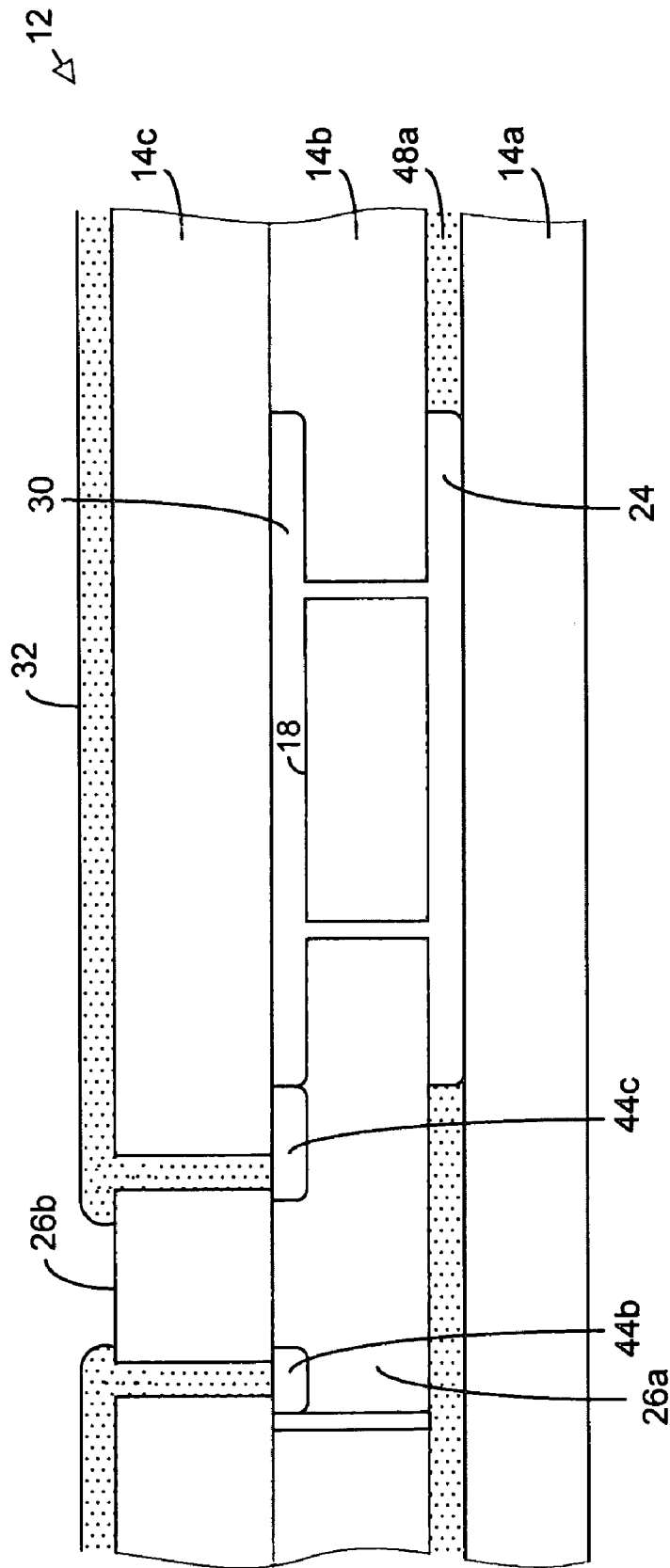

FIGURE 39J

10

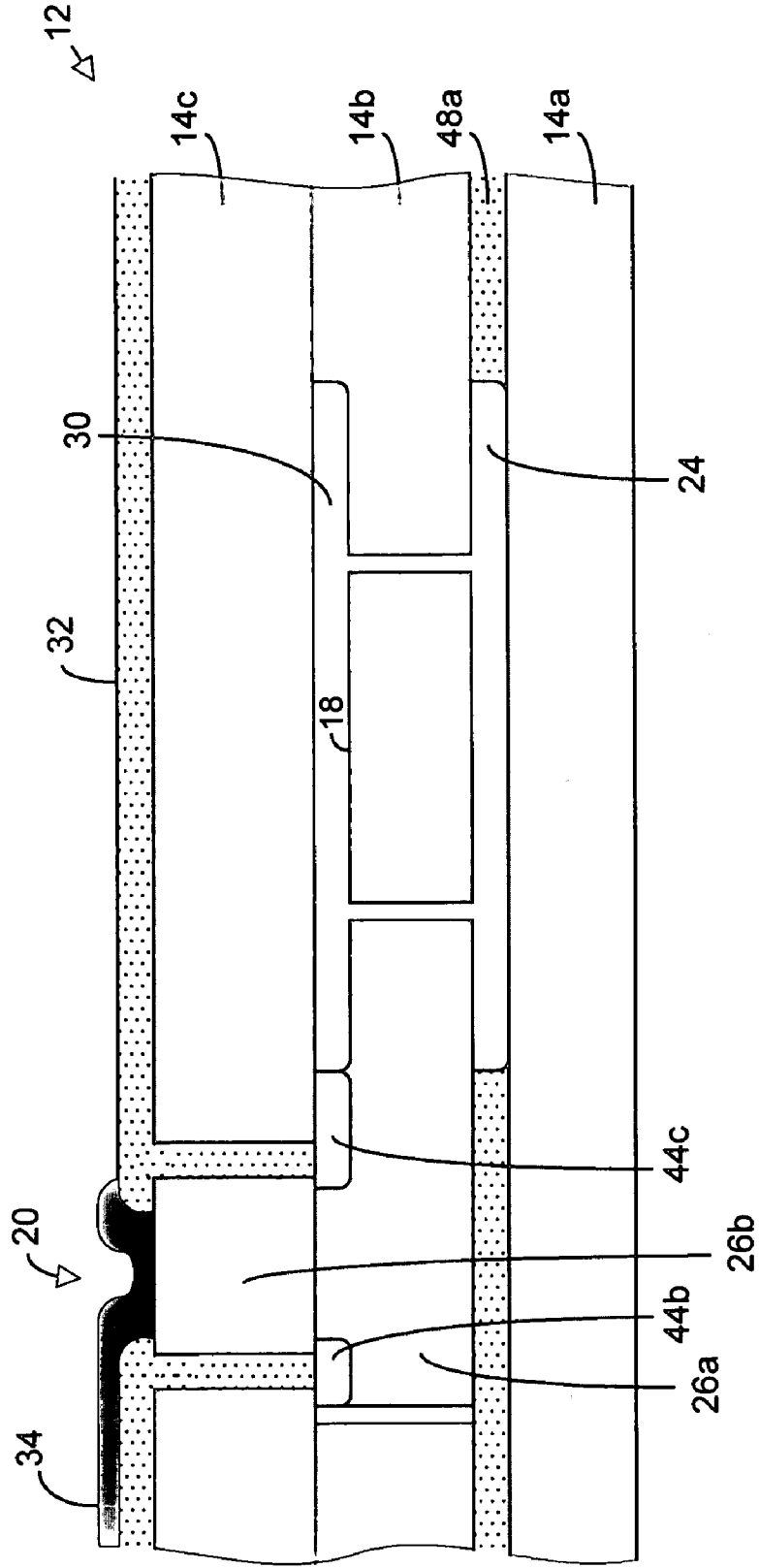

FIGURE 39K

10

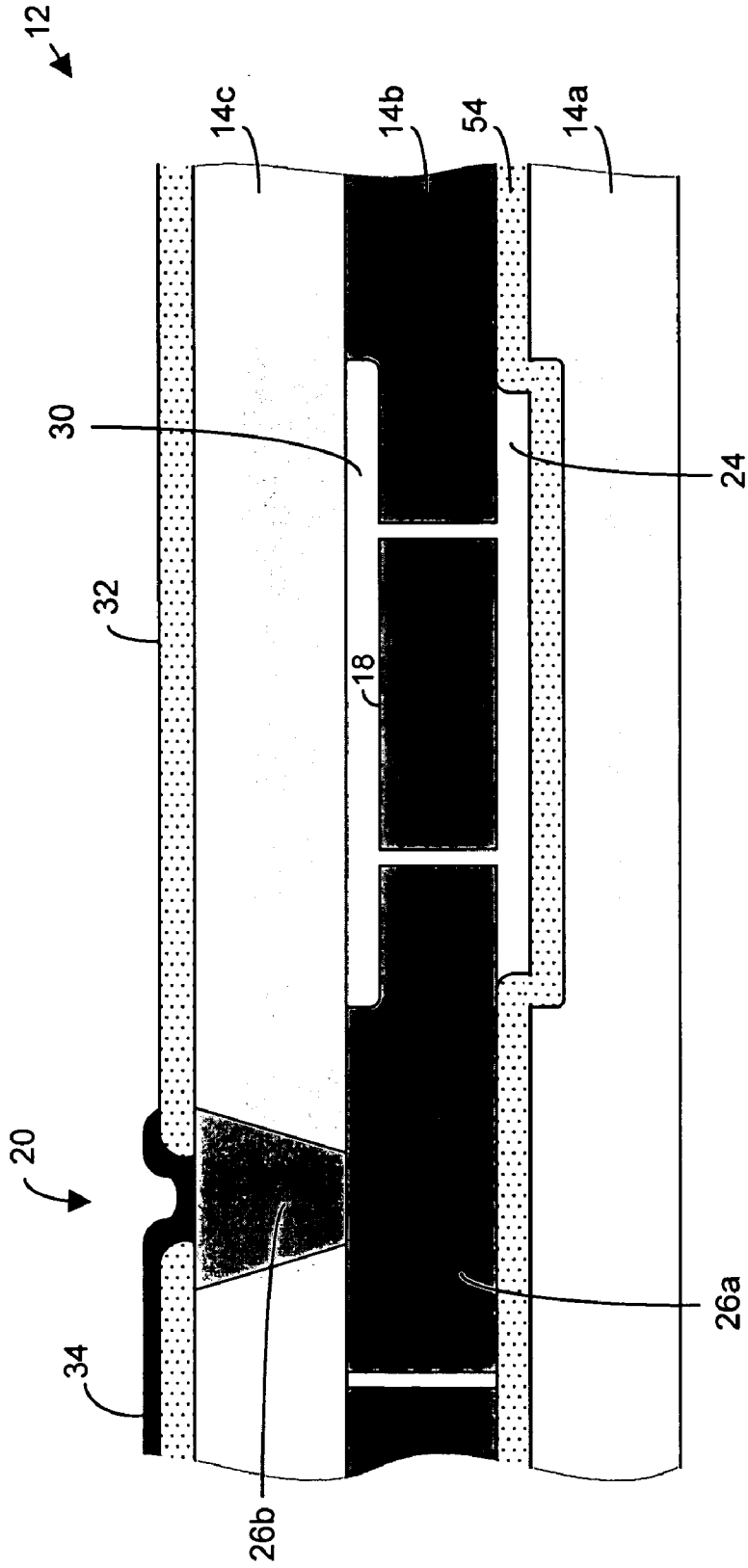

FIGURE 40

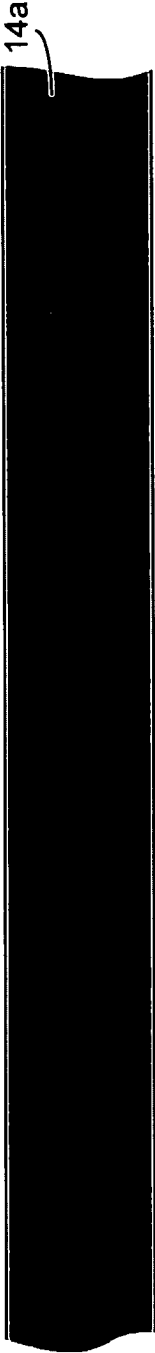

FIGURE 41A

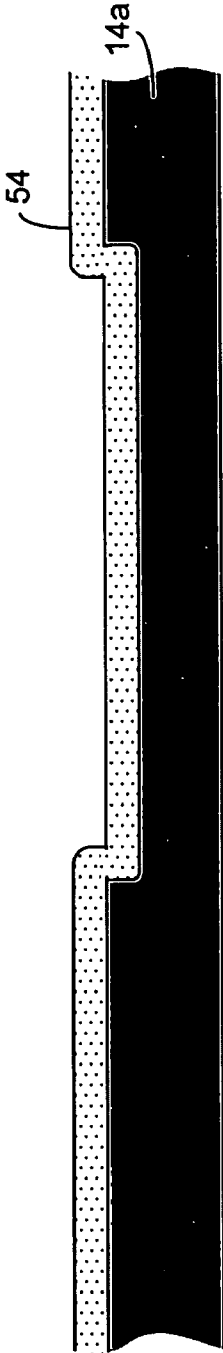

FIGURE 41B

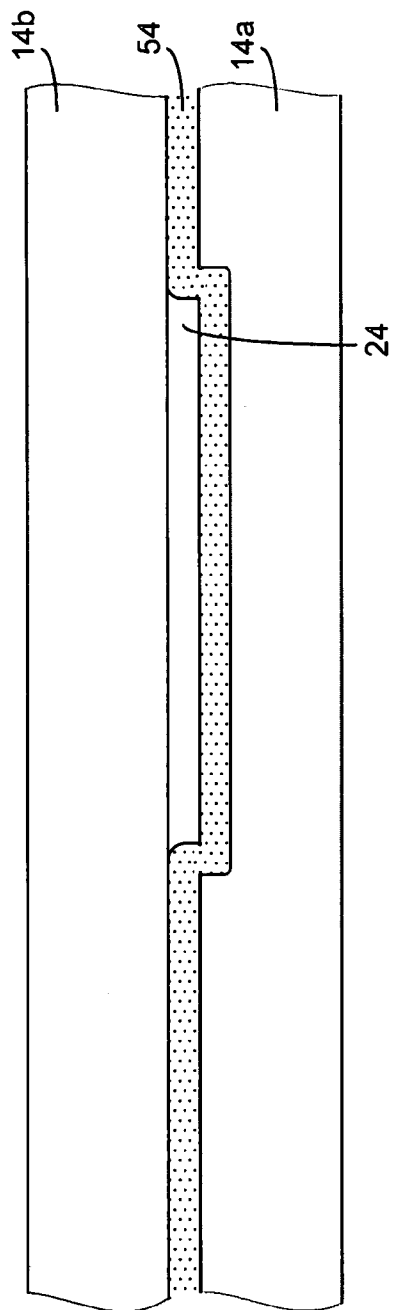

FIGURE 41C

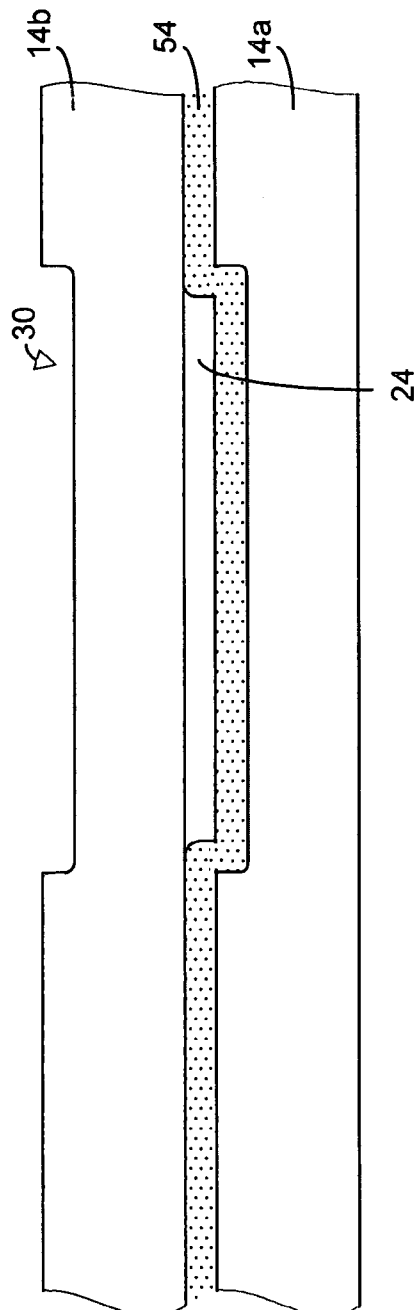

FIGURE 41D

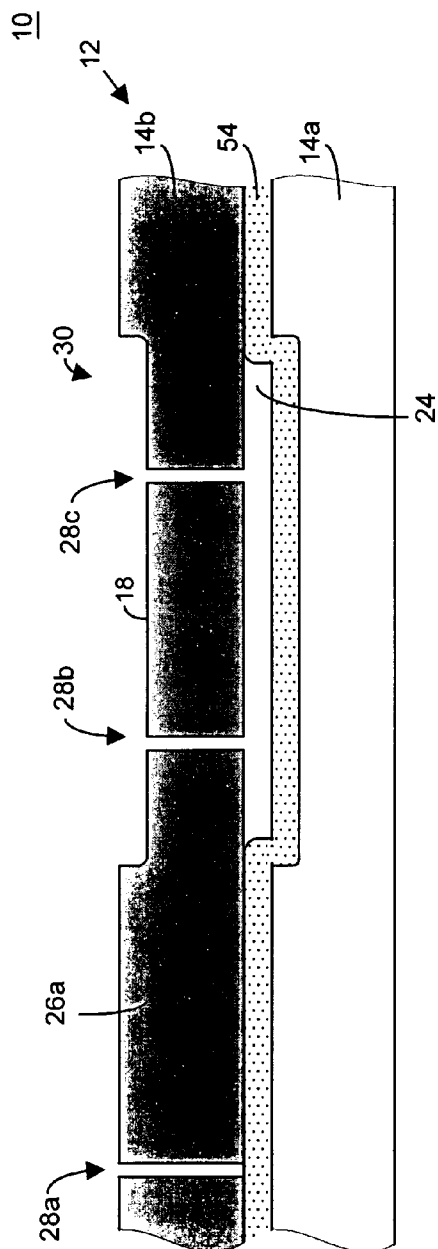

FIGURE 41E

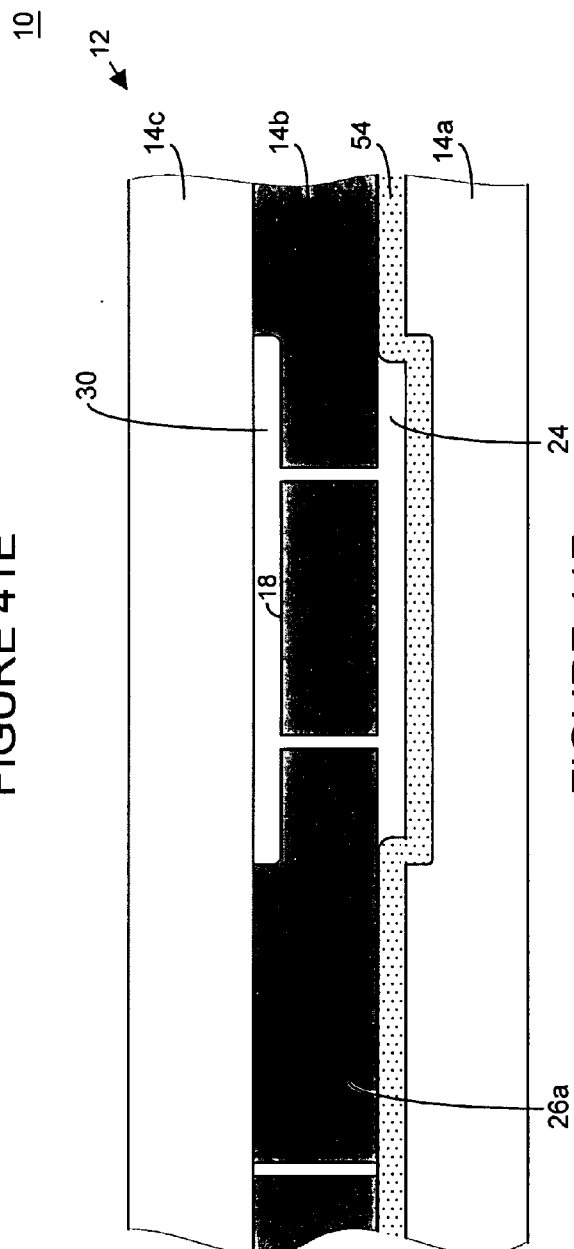

FIGURE 41F

10

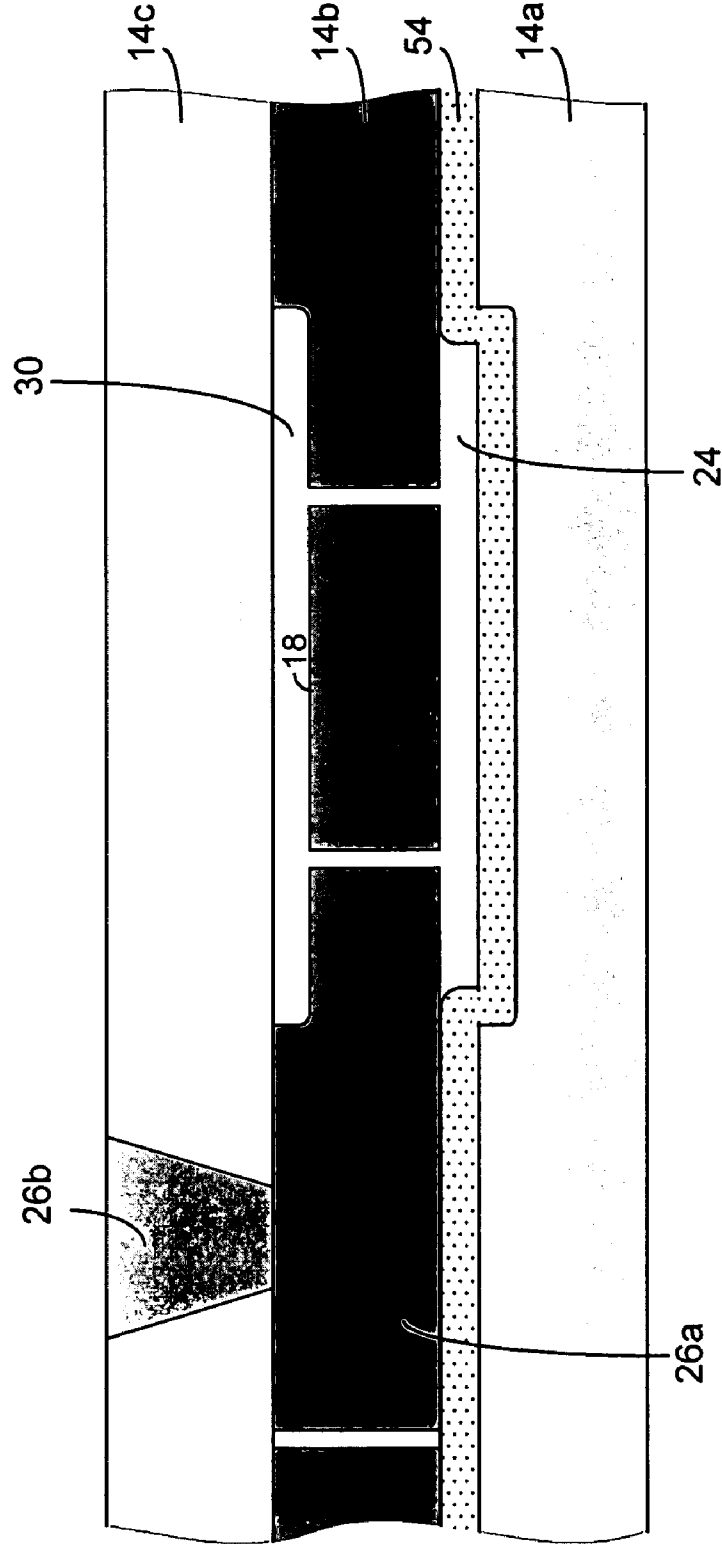

FIGURE 41G

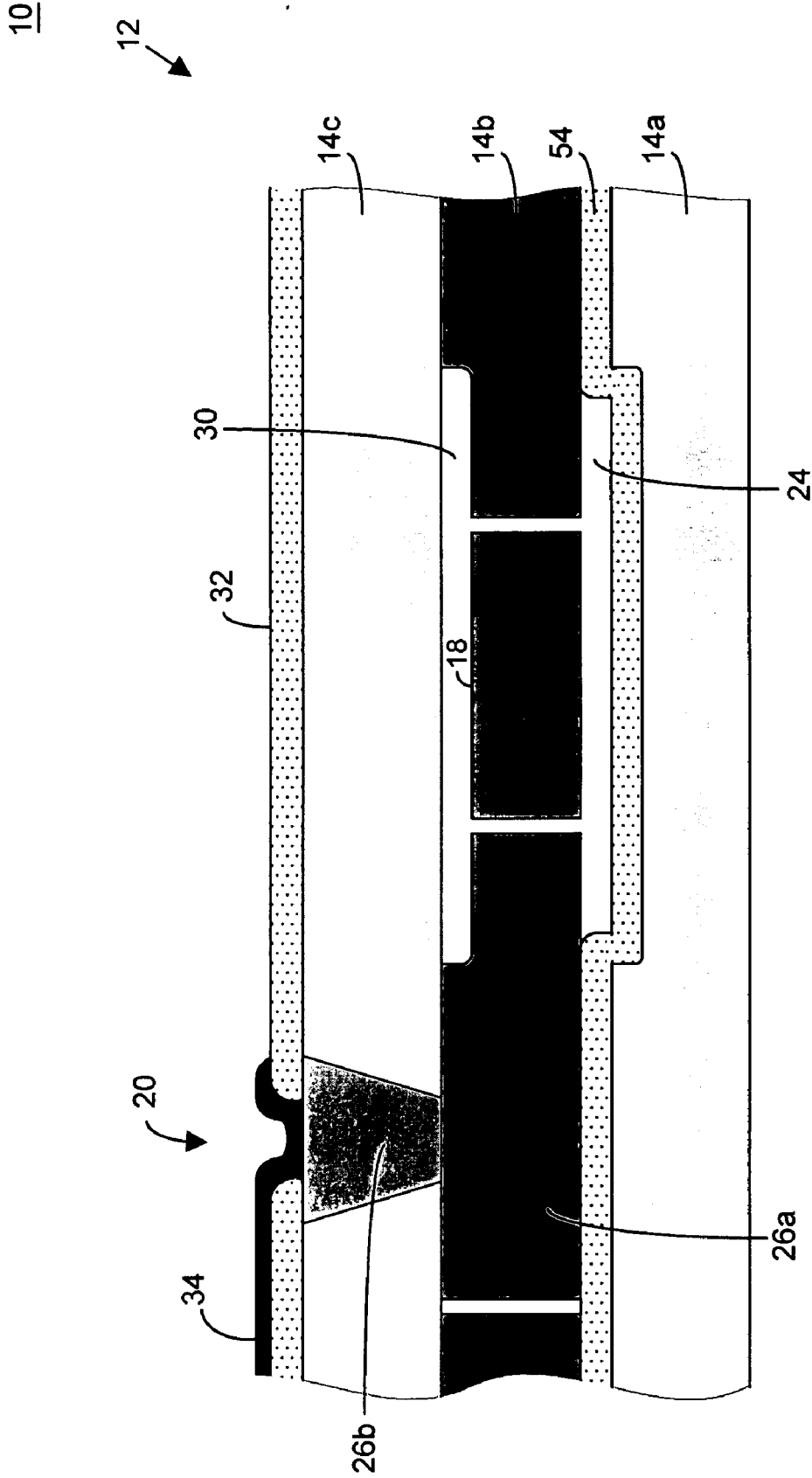

FIGURE 41H

10

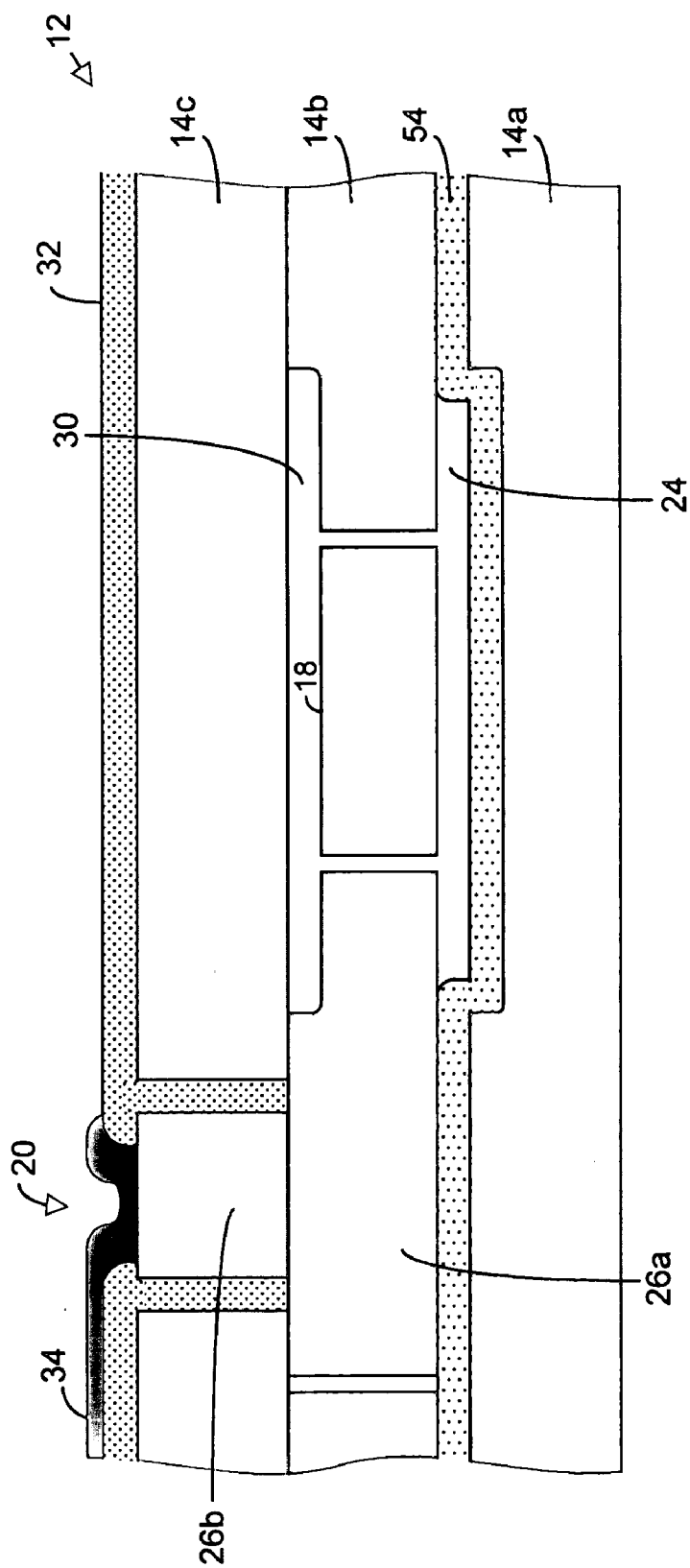

FIGURE 42A

10

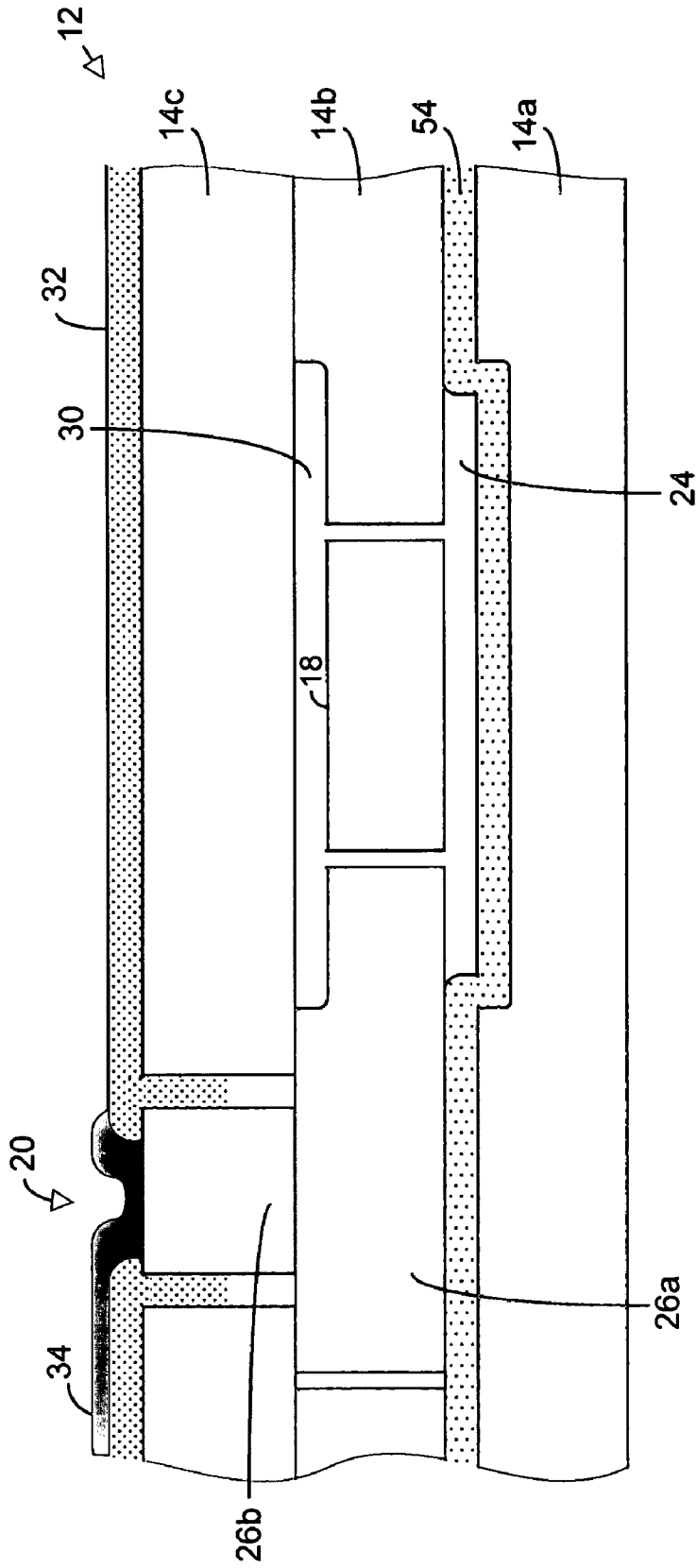

FIGURE 42B



FIGURE 43A

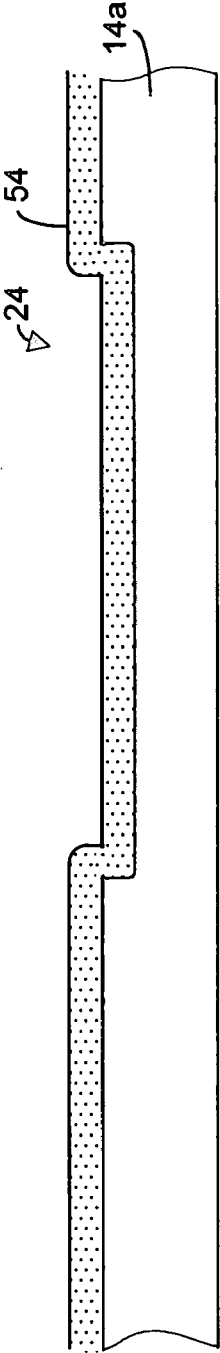

FIGURE 43B

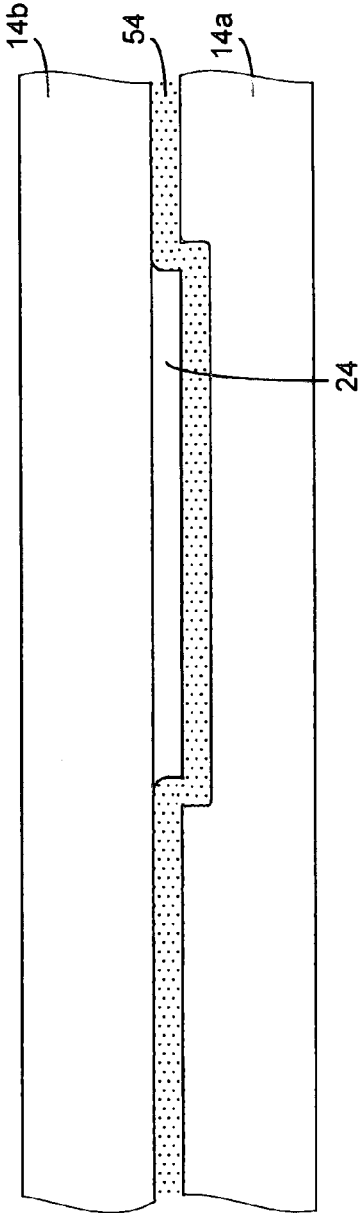

FIGURE 43C

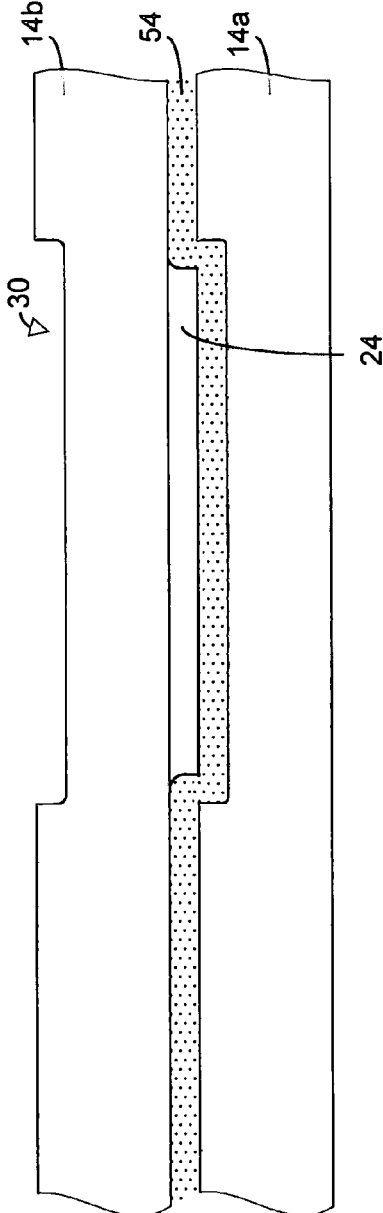

FIGURE 43D

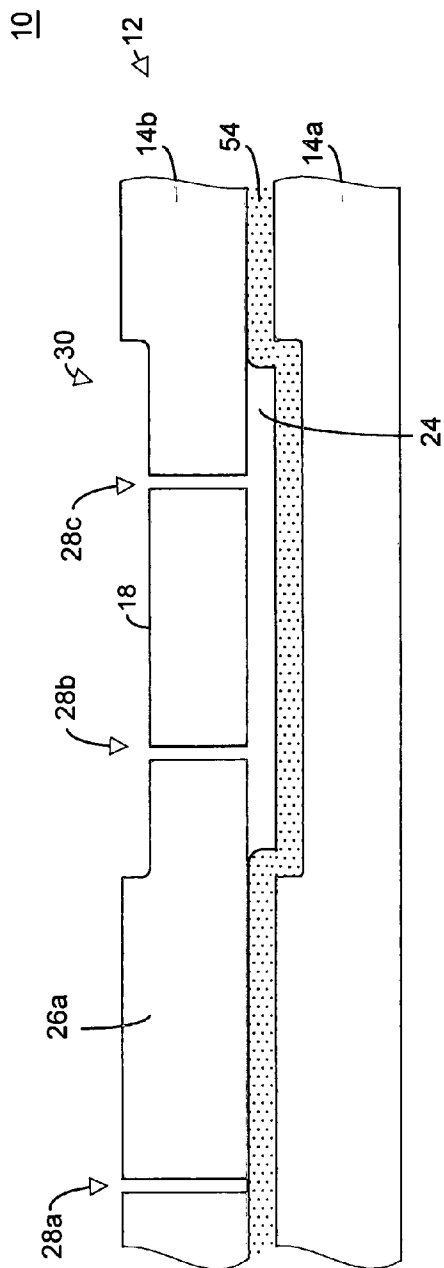

FIGURE 43E

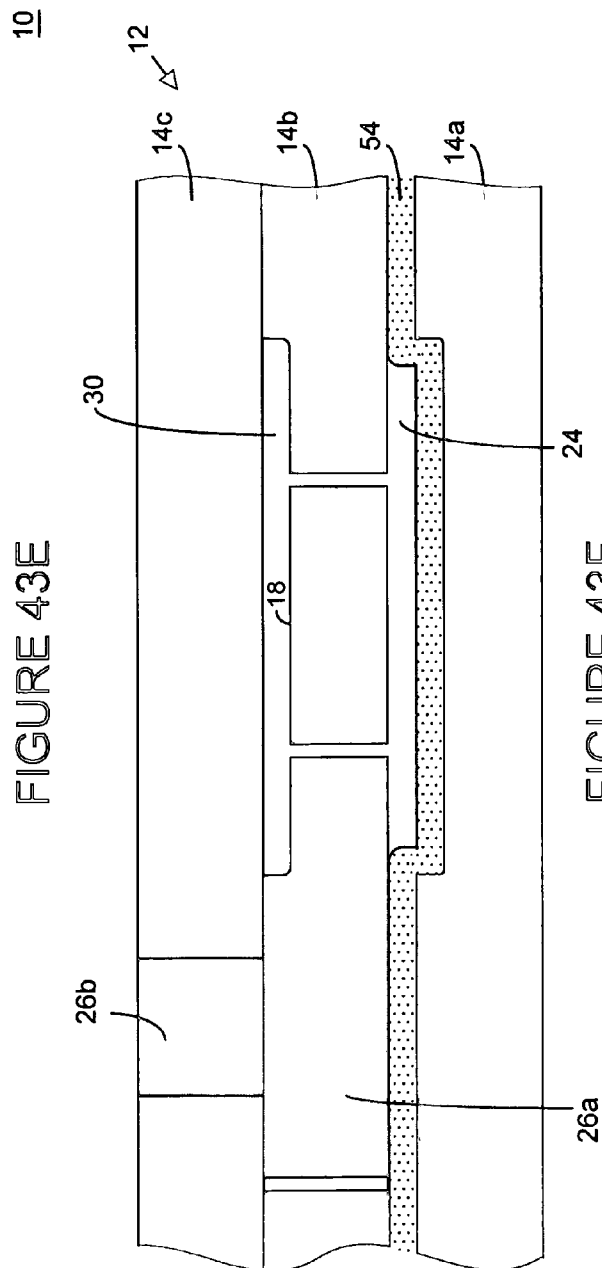

FIGURE 43F

10

12

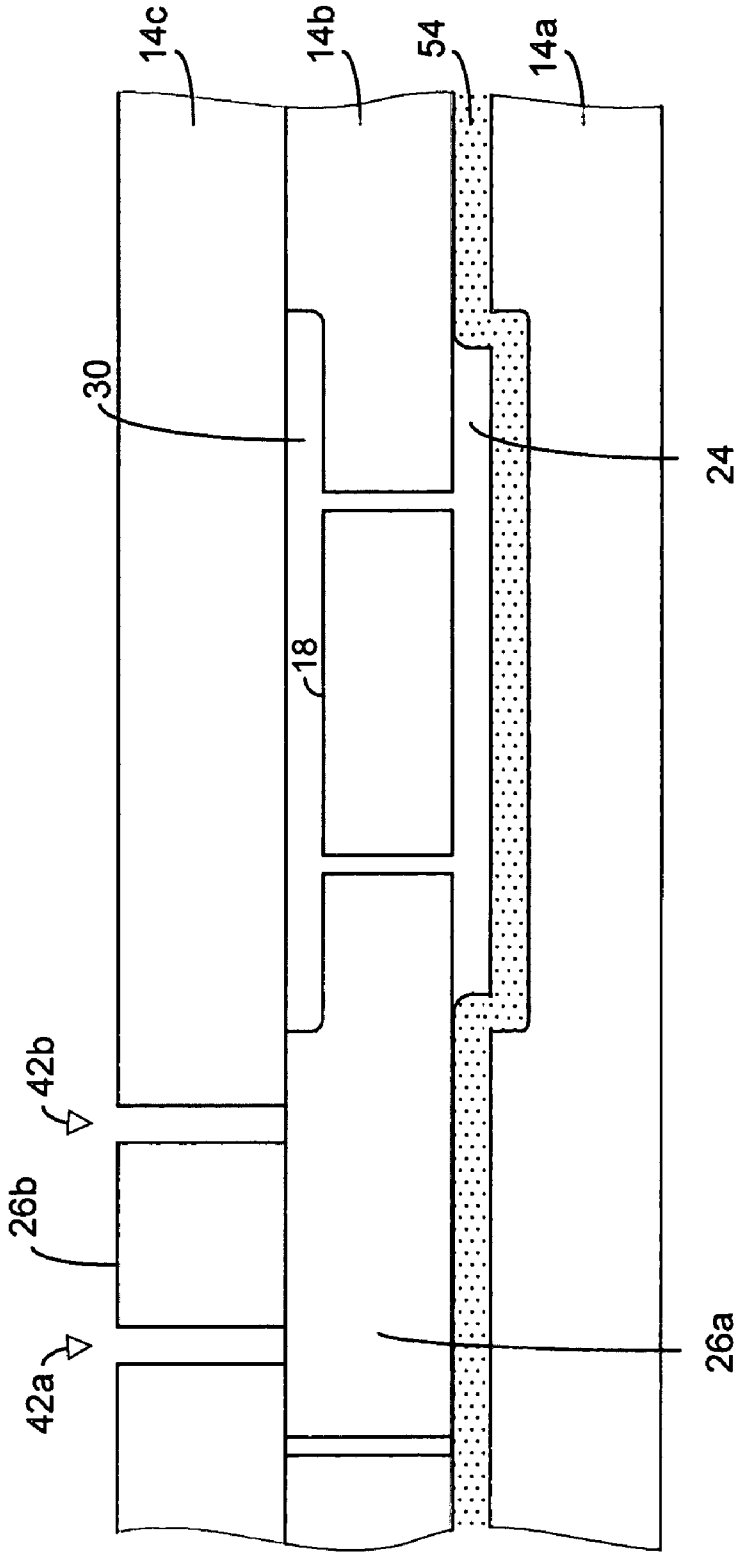

FIGURE 43G

10

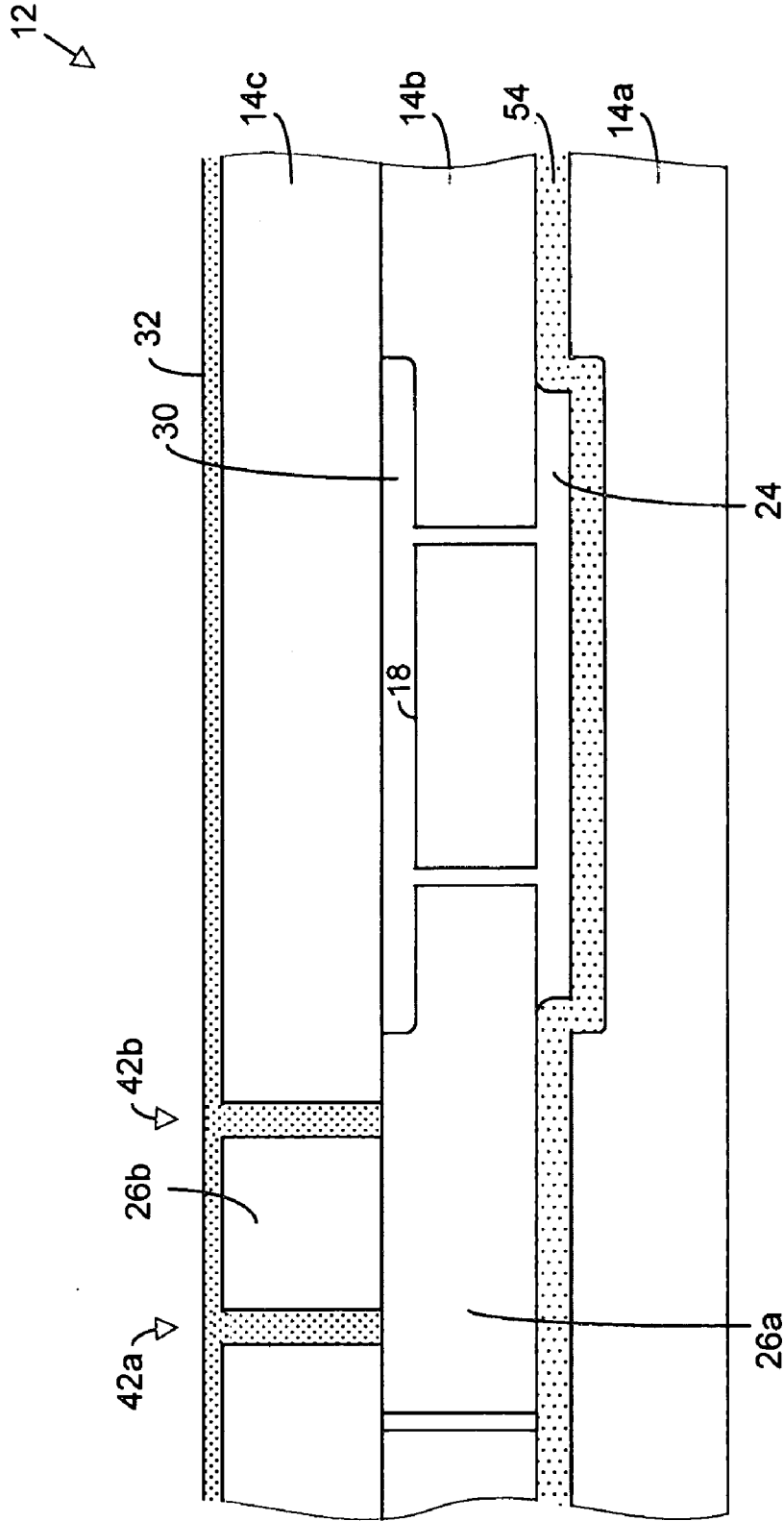

FIGURE 43H

10

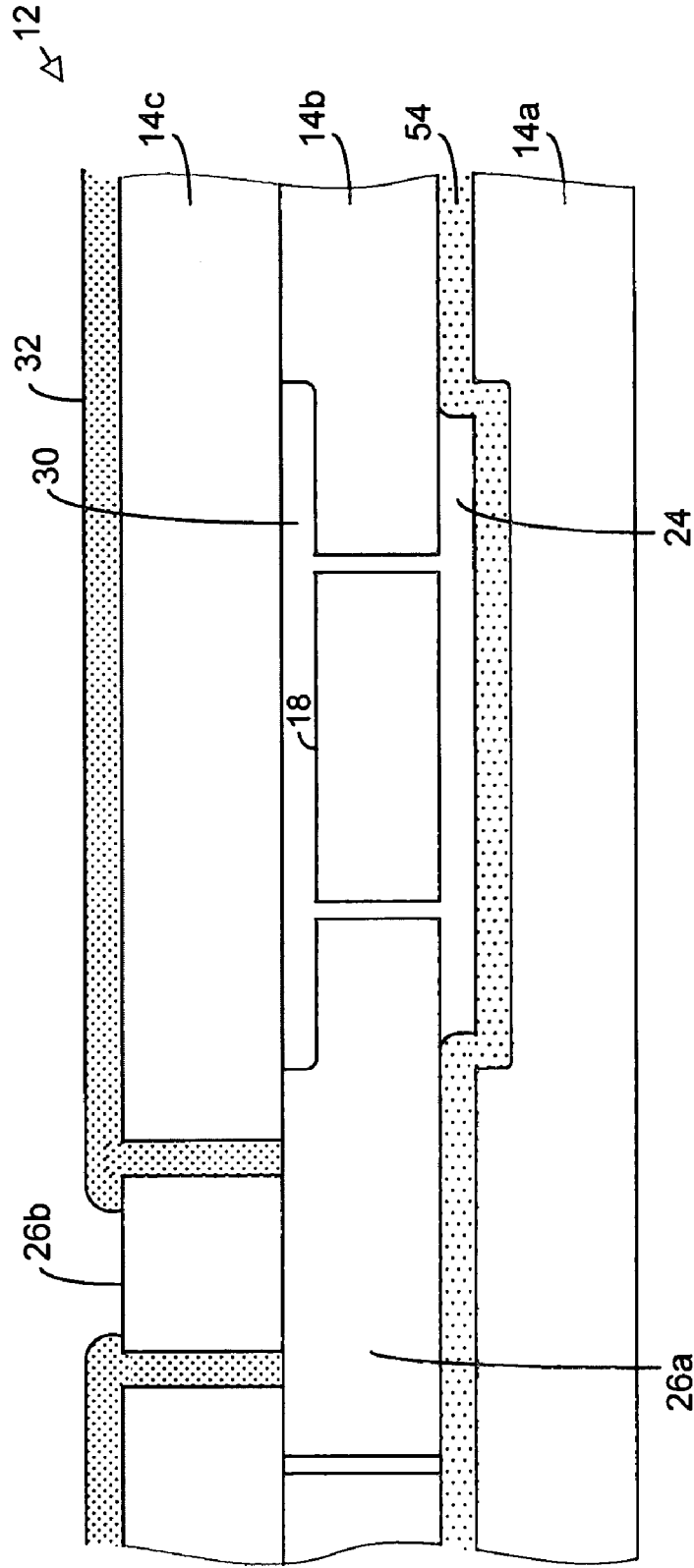

FIGURE 43I

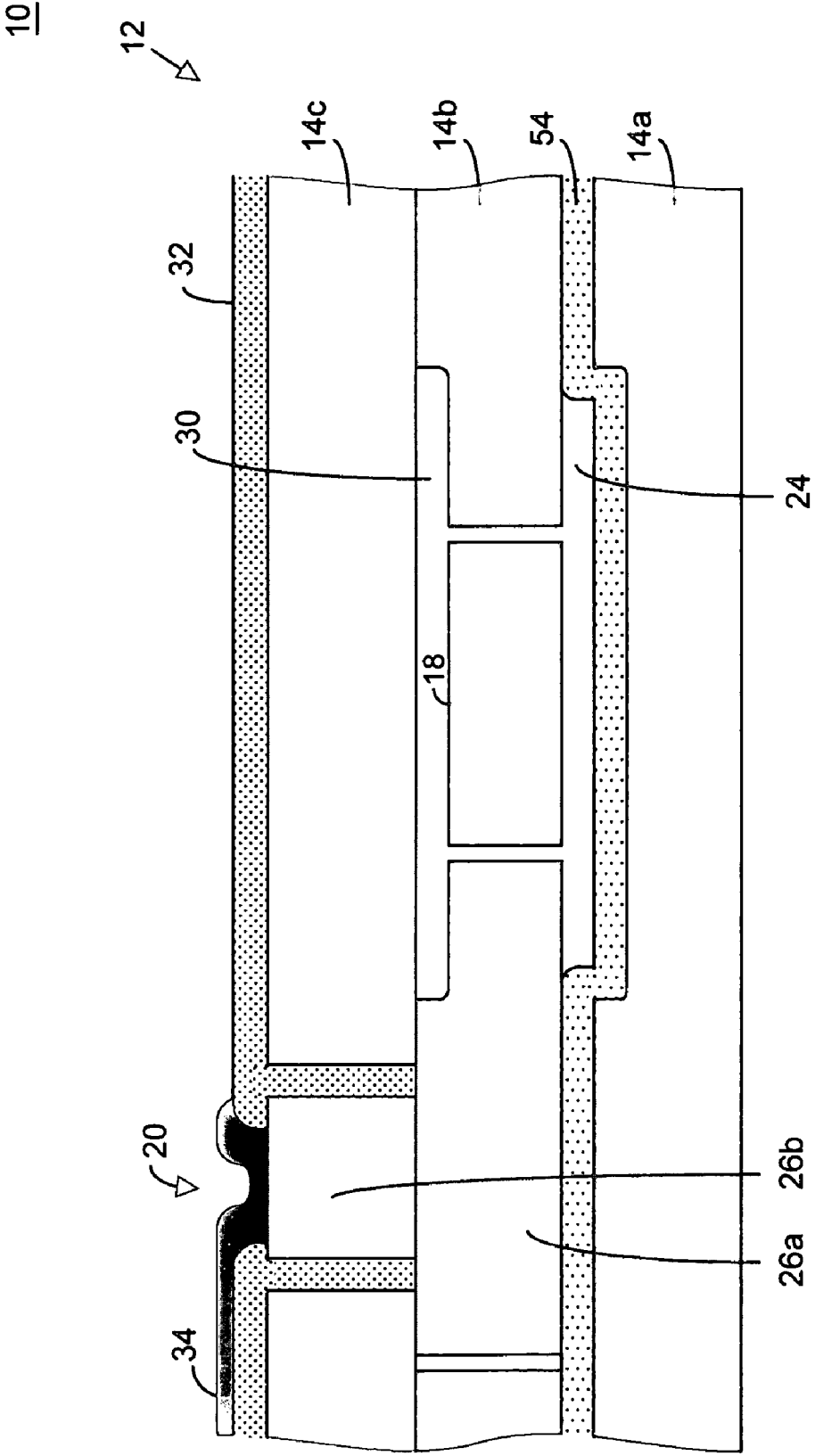

FIGURE 43J

10

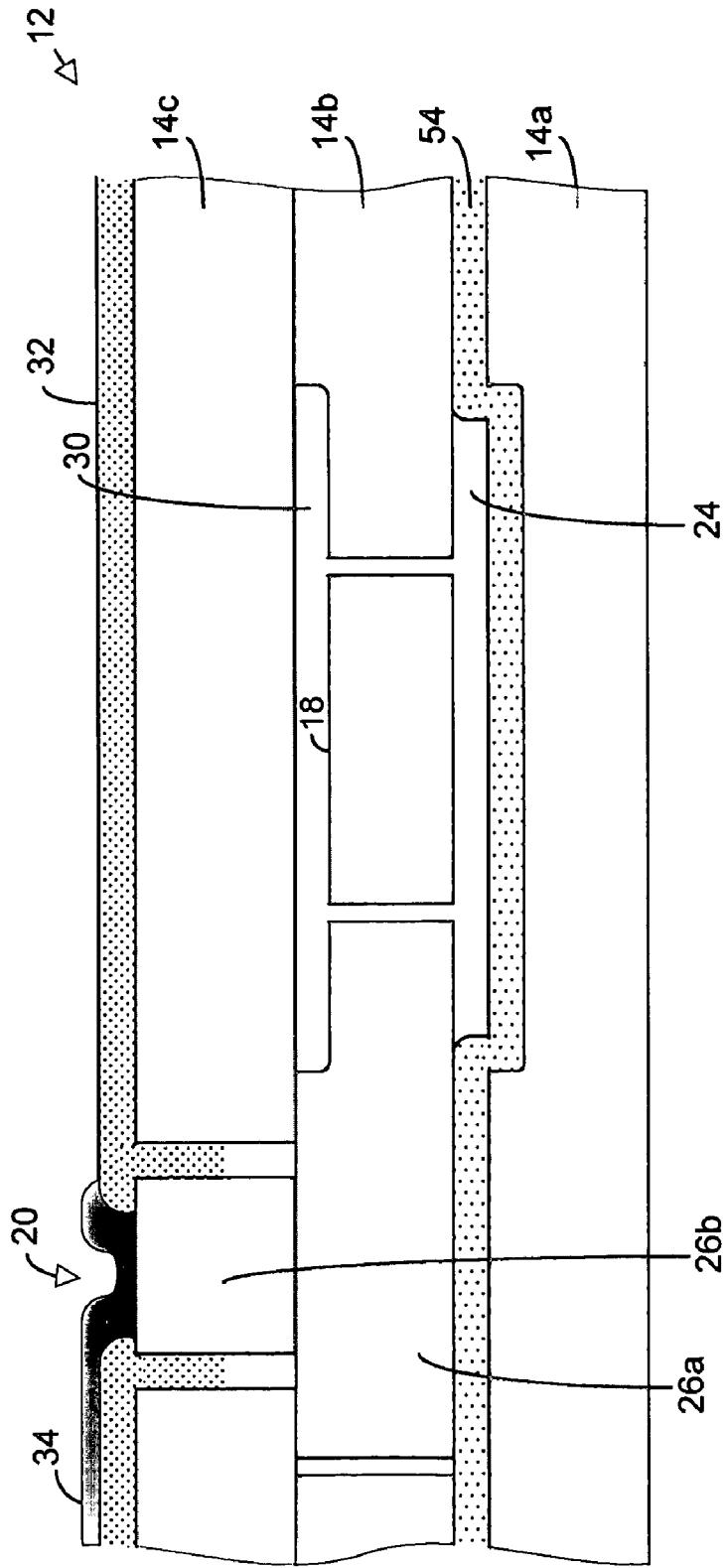

FIGURE 43K

10

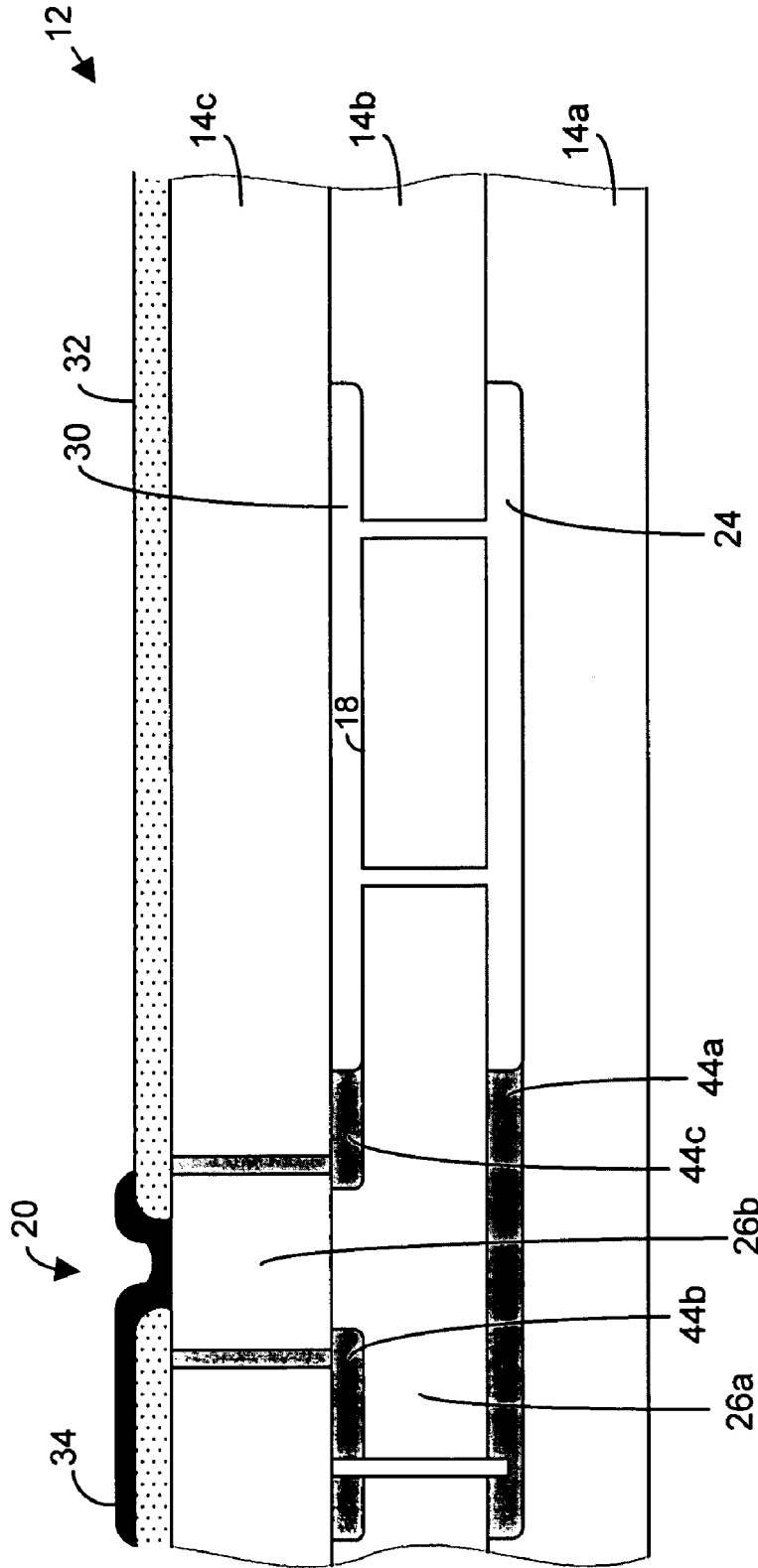

FIGURE 44



FIGURE 45A

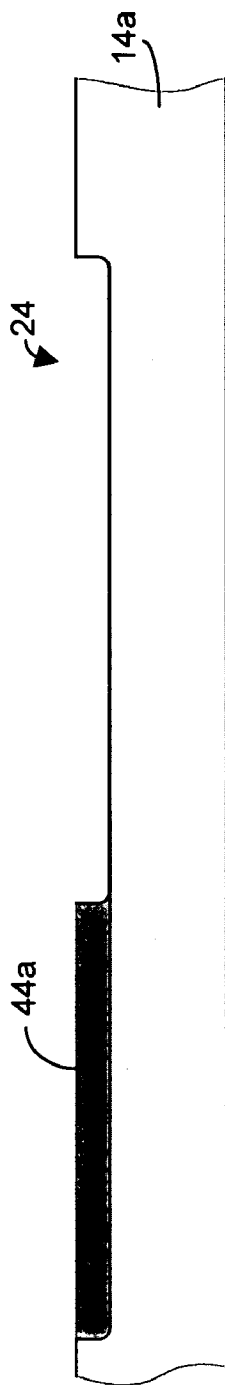

FIGURE 45B

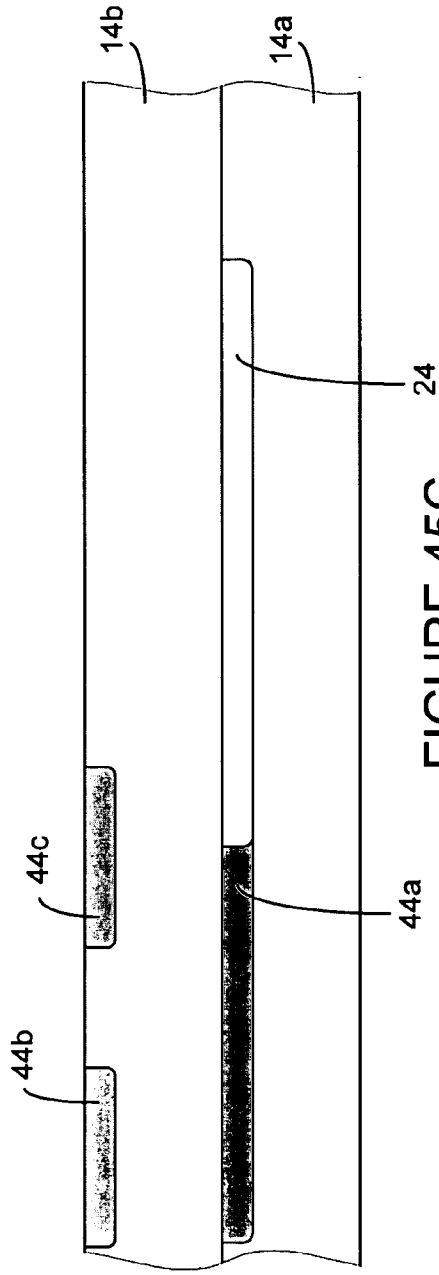

FIGURE 45C

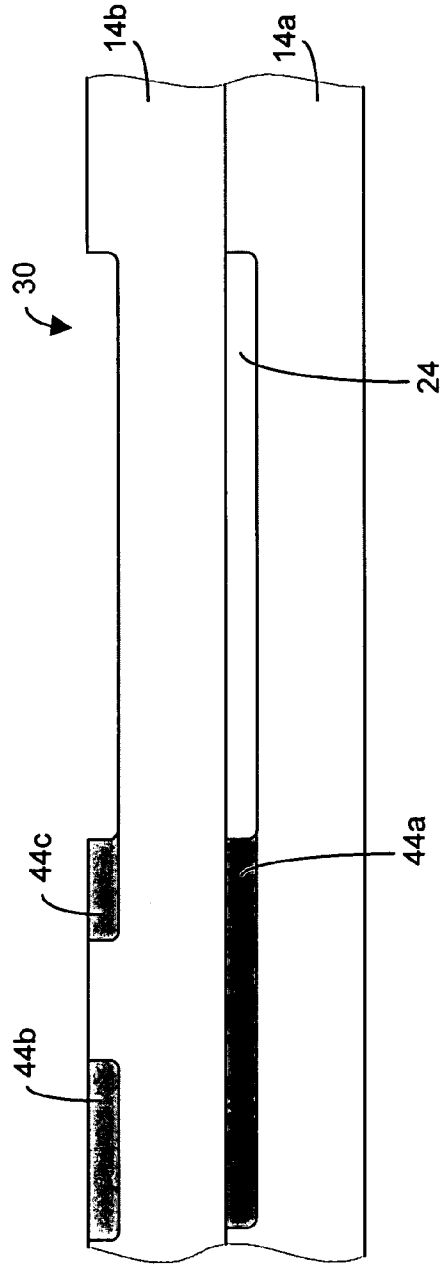

FIGURE 45D

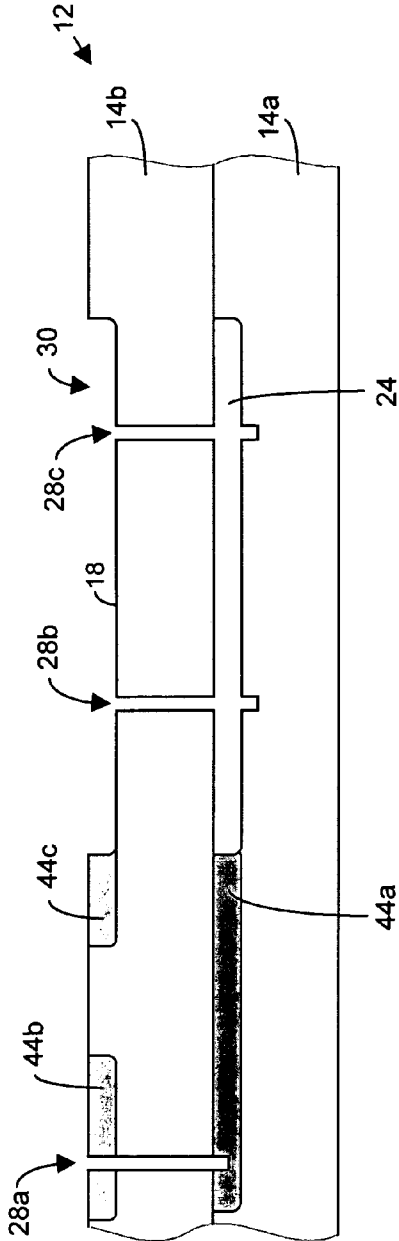

FIGURE 45E

10

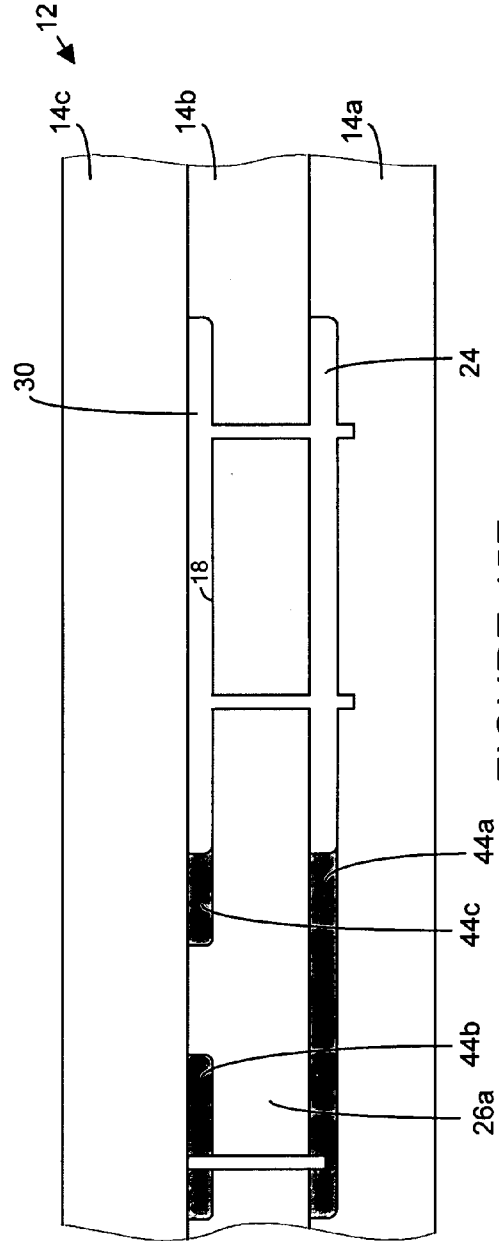

FIGURE 45F

10

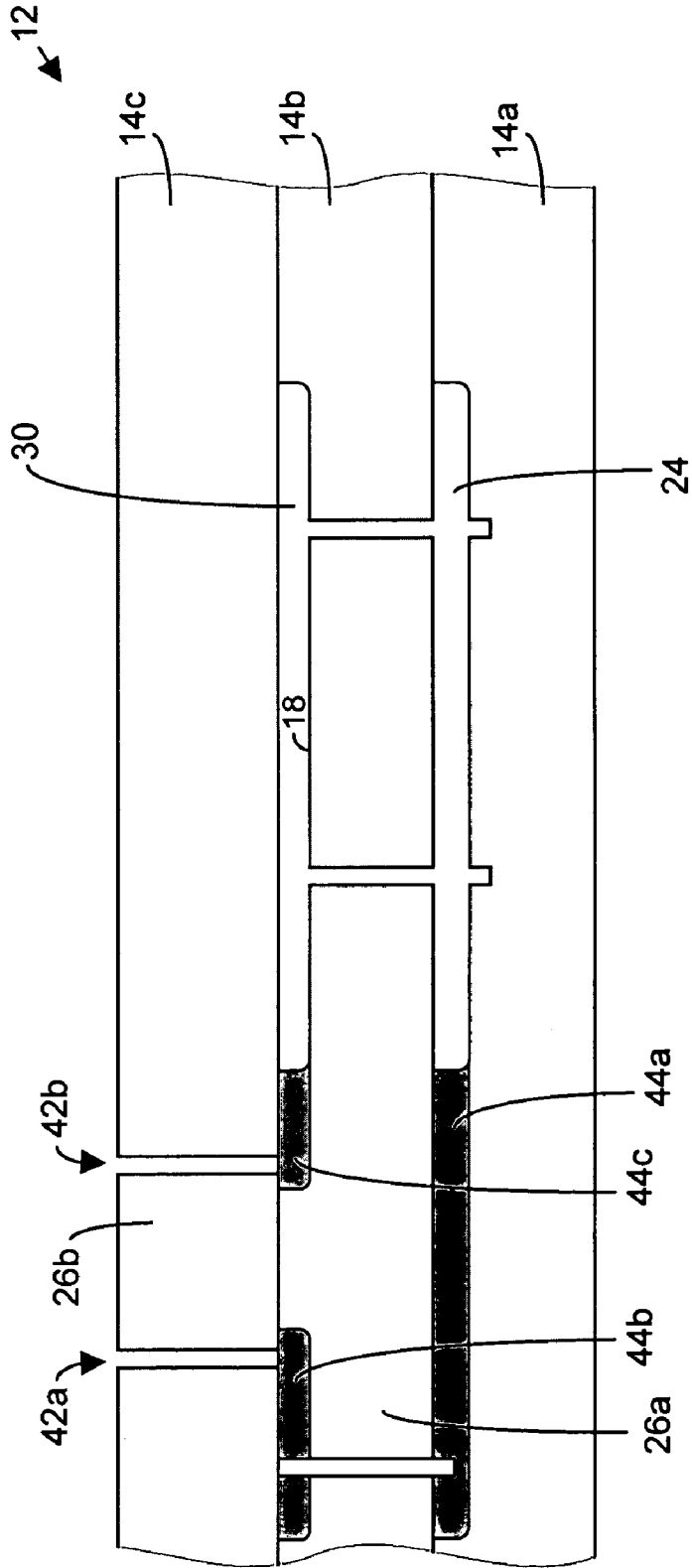

FIGURE 45G

10

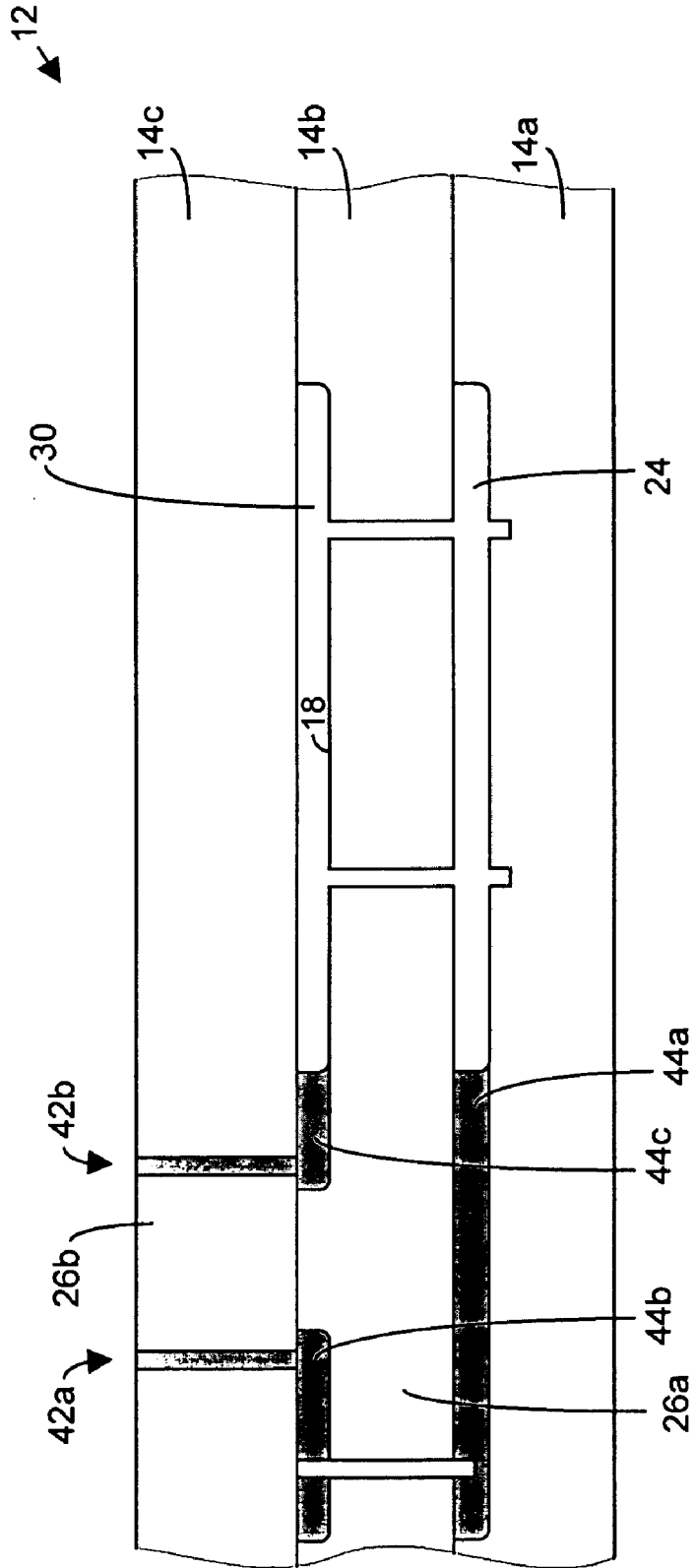

FIGURE 45H

10

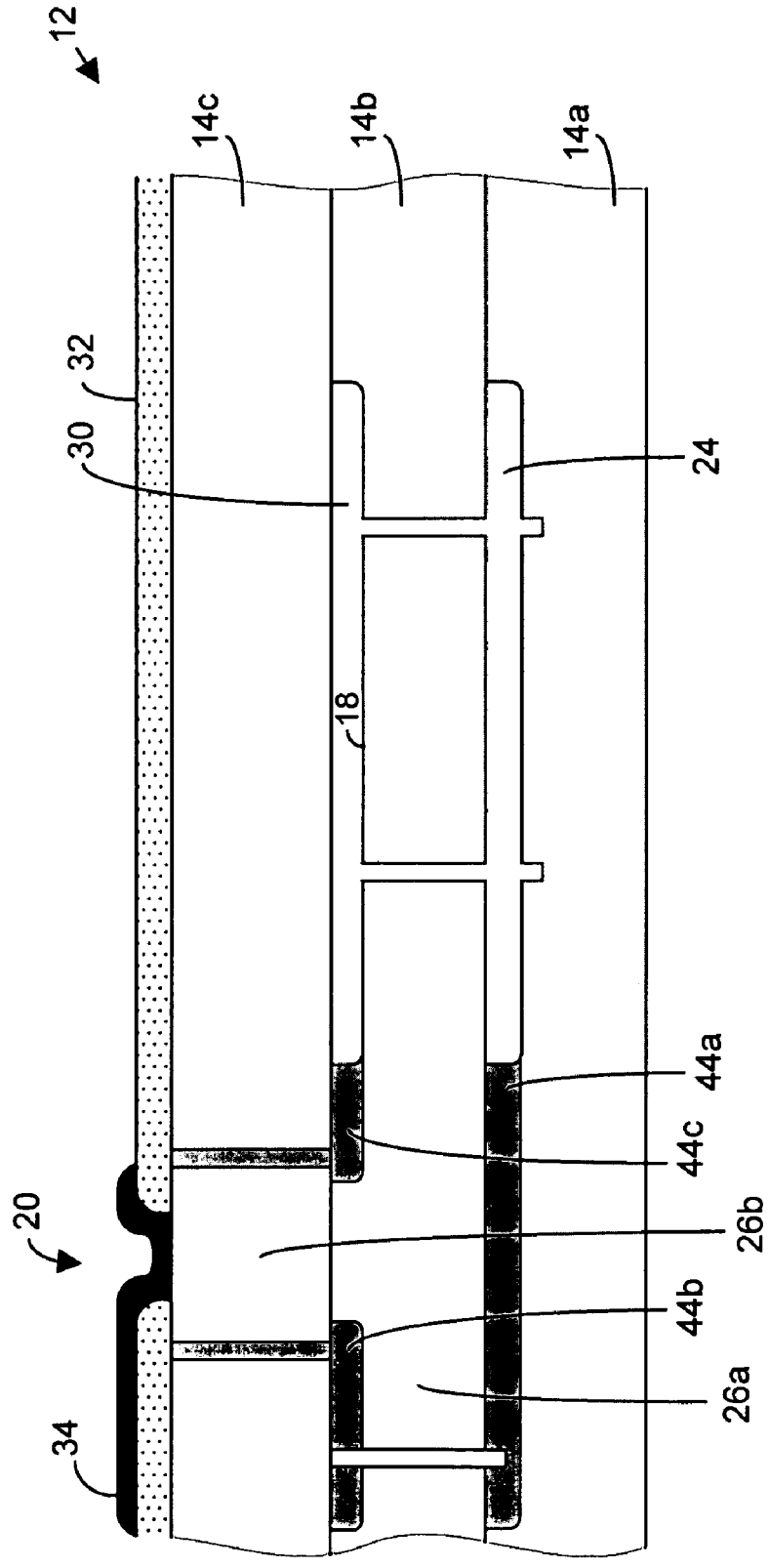

FIGURE 45I

10

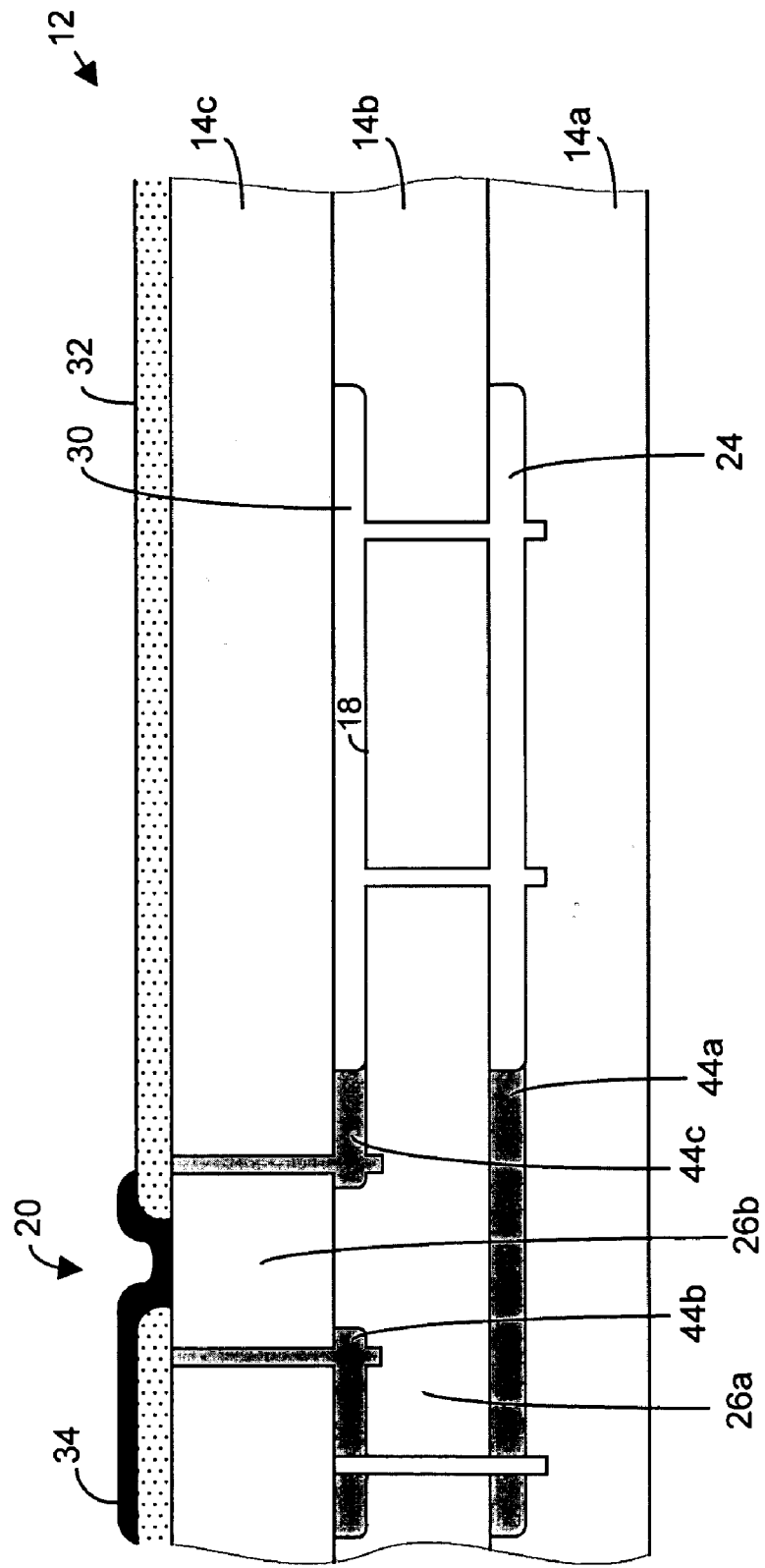

FIGURE 46A

10

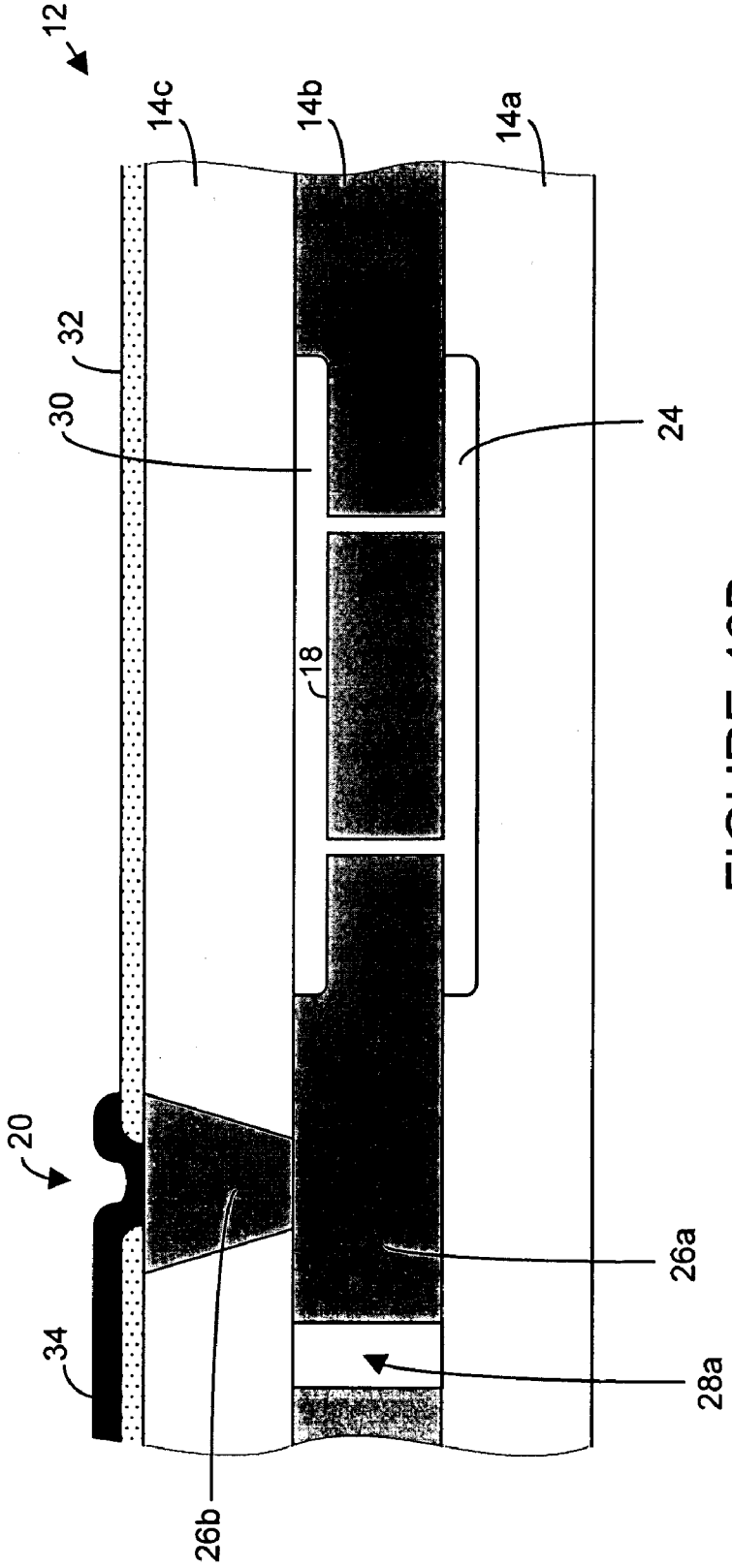

FIGURE 46B

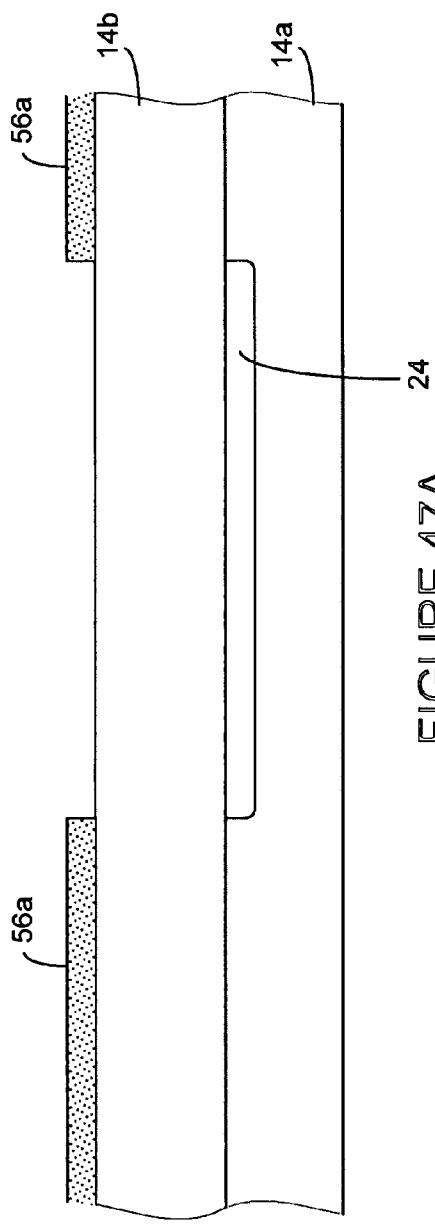

FIGURE 47A

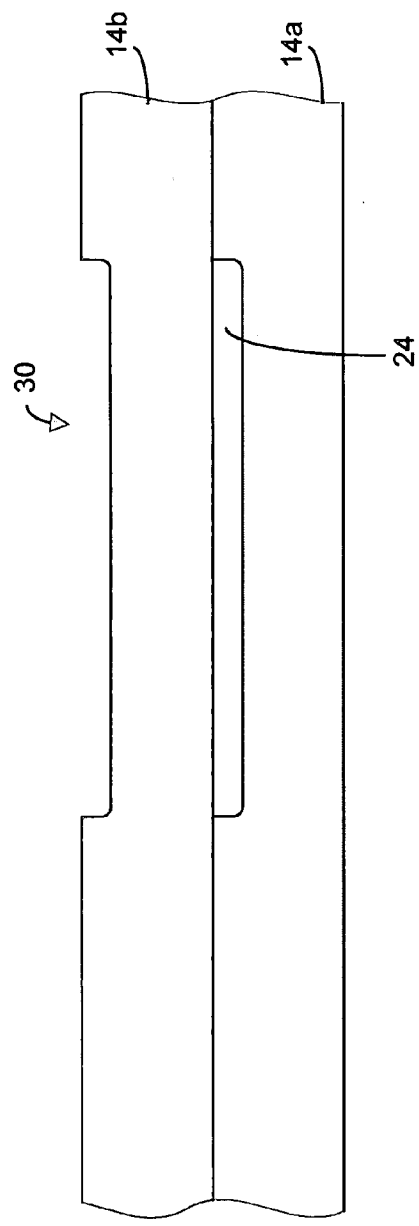

FIGURE 47B

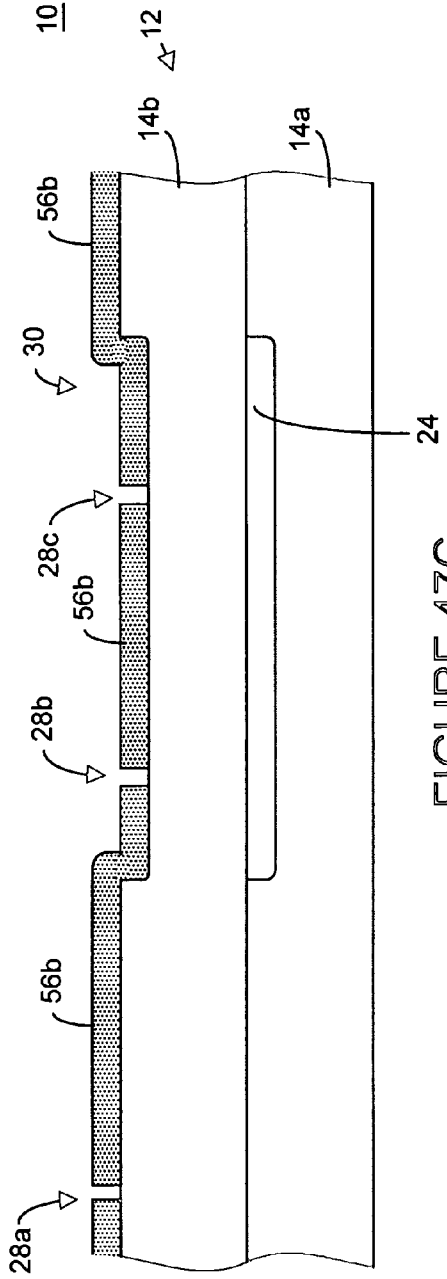

FIGURE 47C

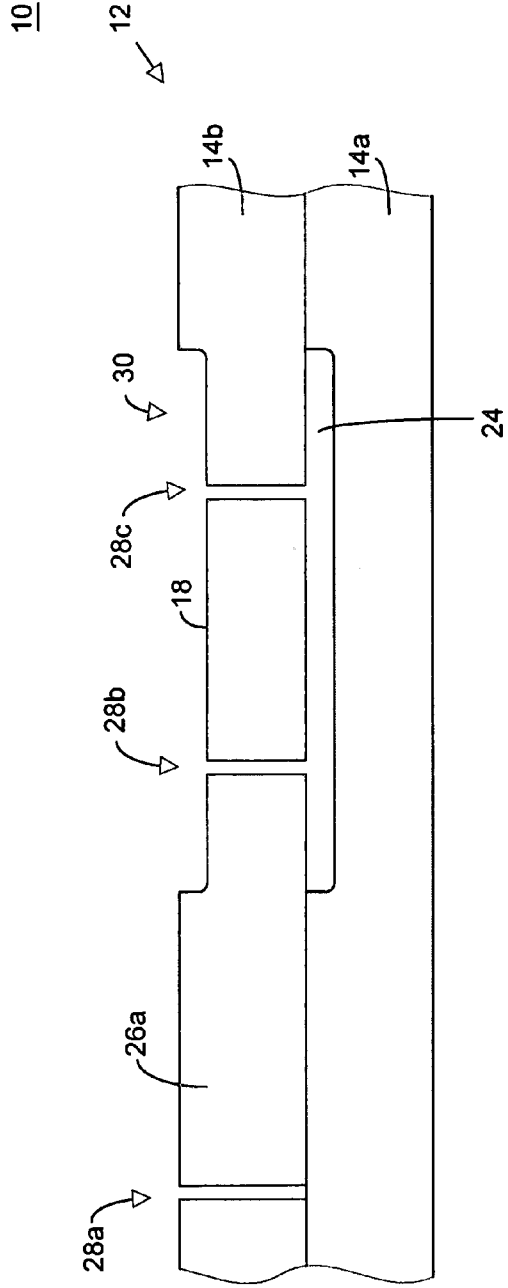

FIGURE 47D

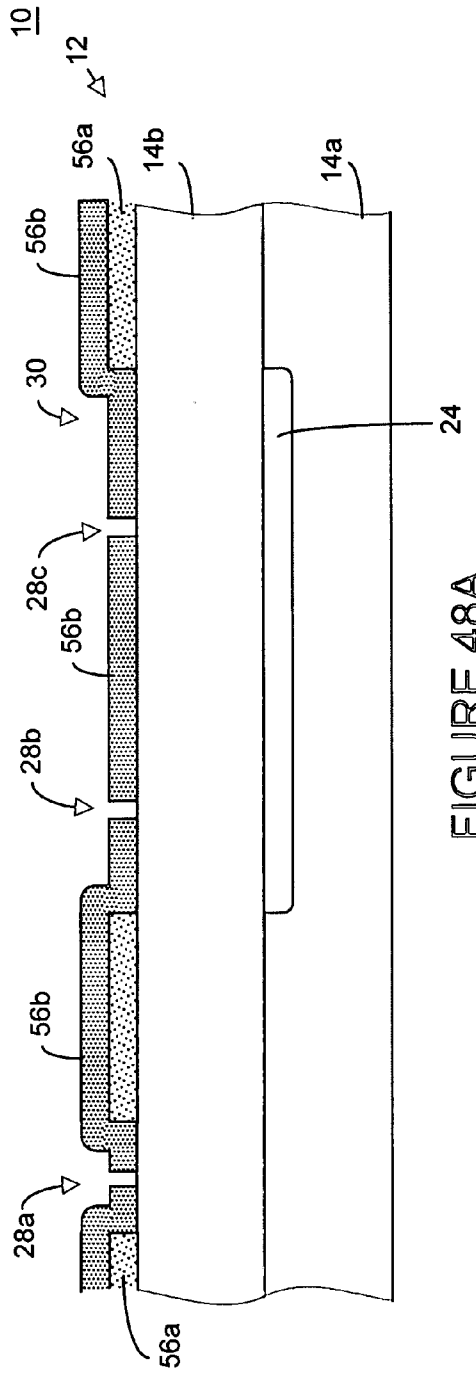

FIGURE 48A

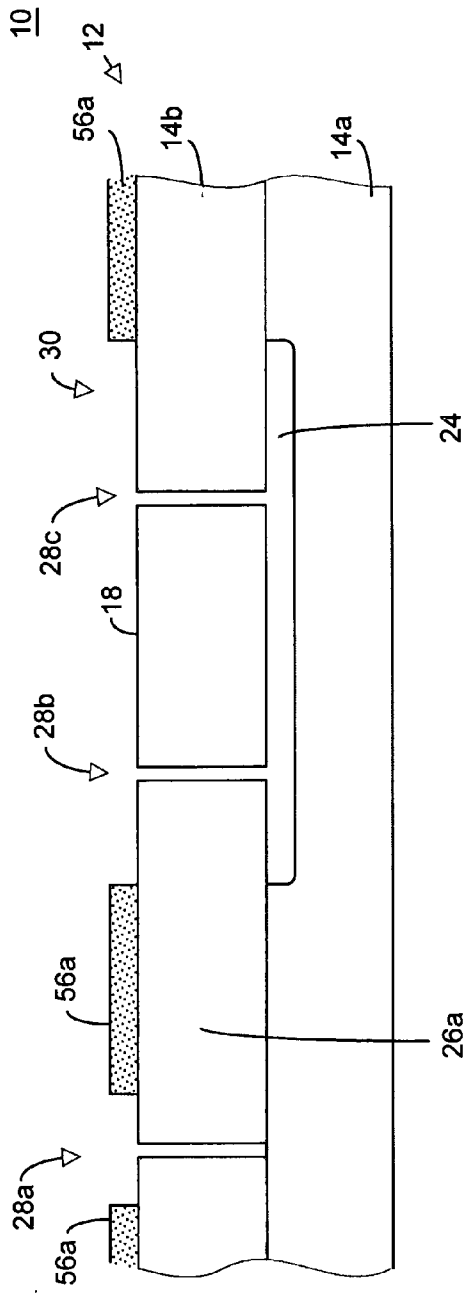

FIGURE 48B

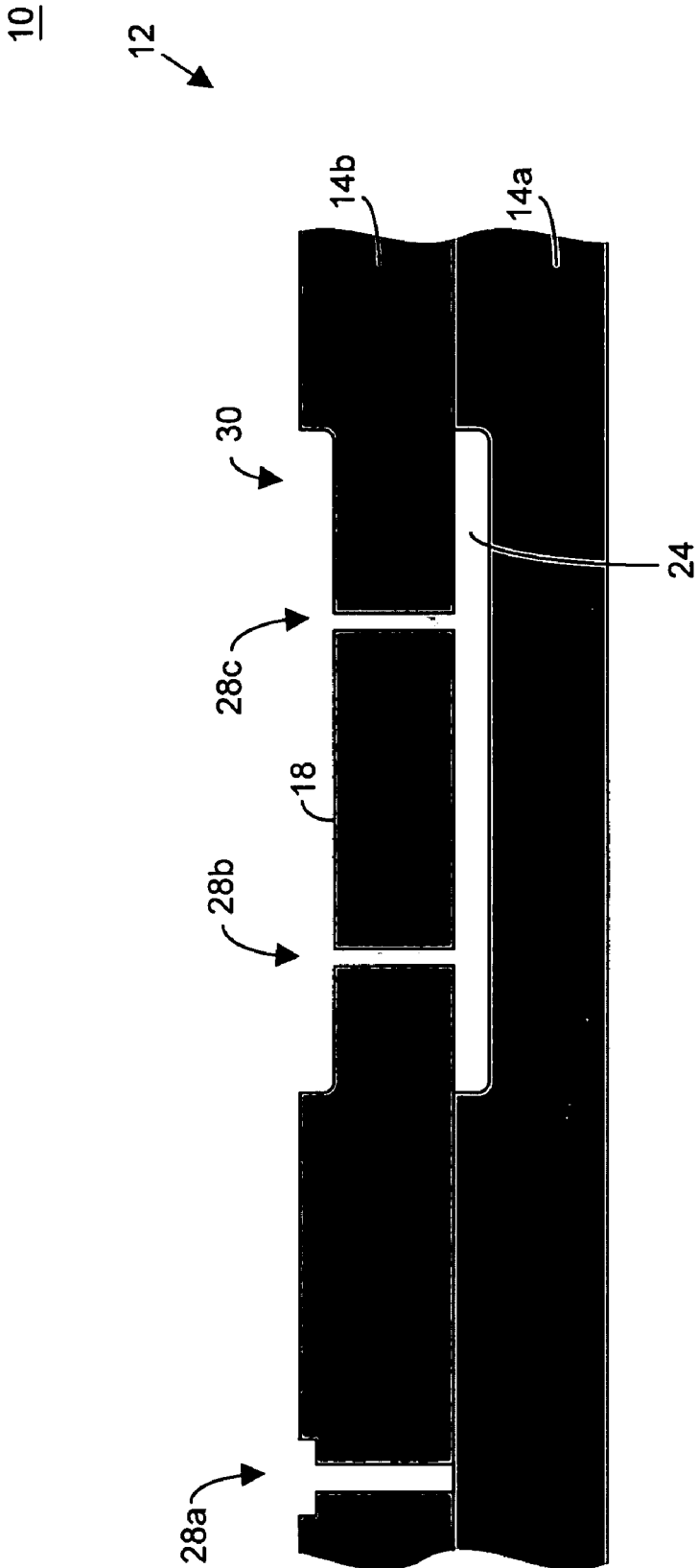

FIGURE 48C

10

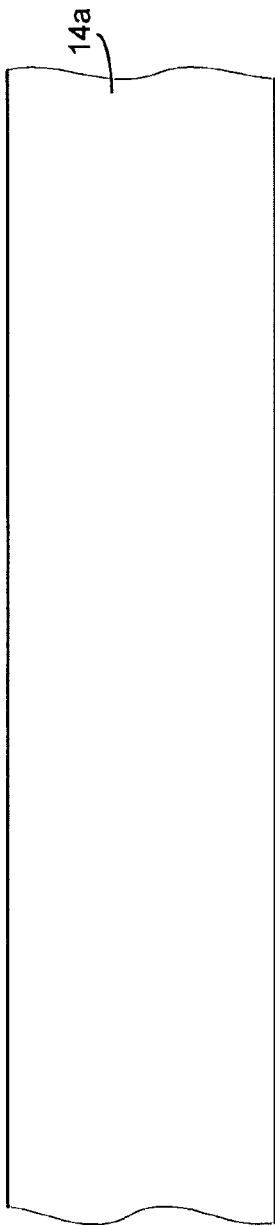

FIGURE 49A

10

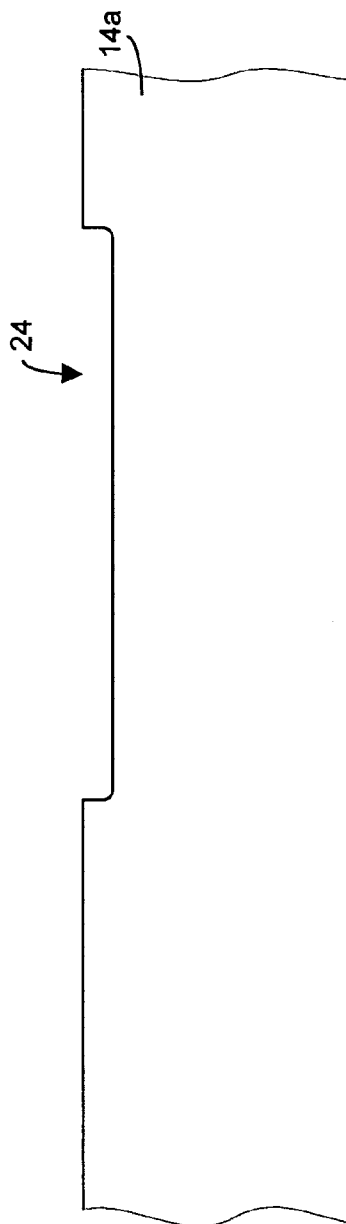

FIGURE 49B

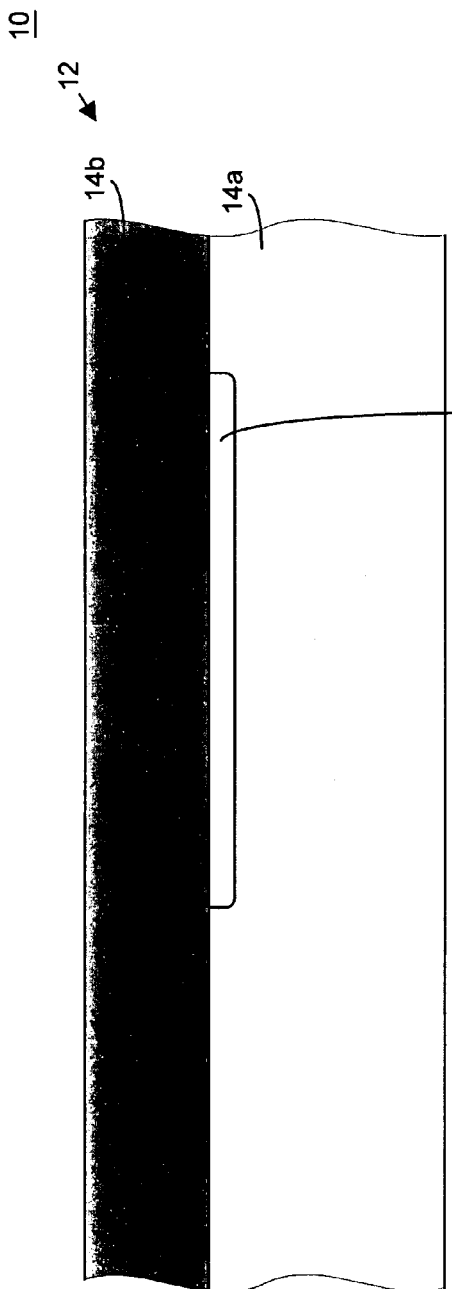

FIGURE 49C

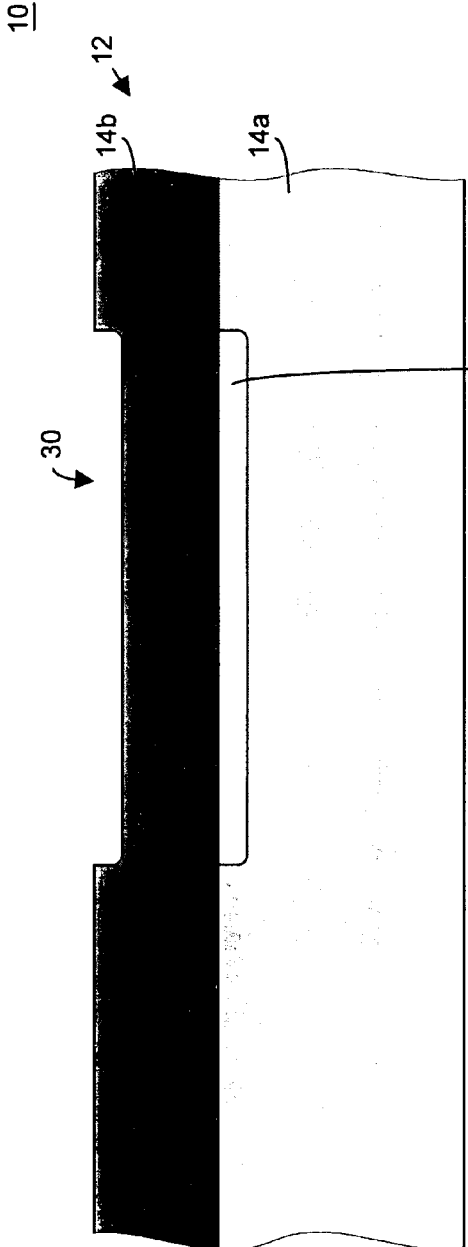

FIGURE 49D

10

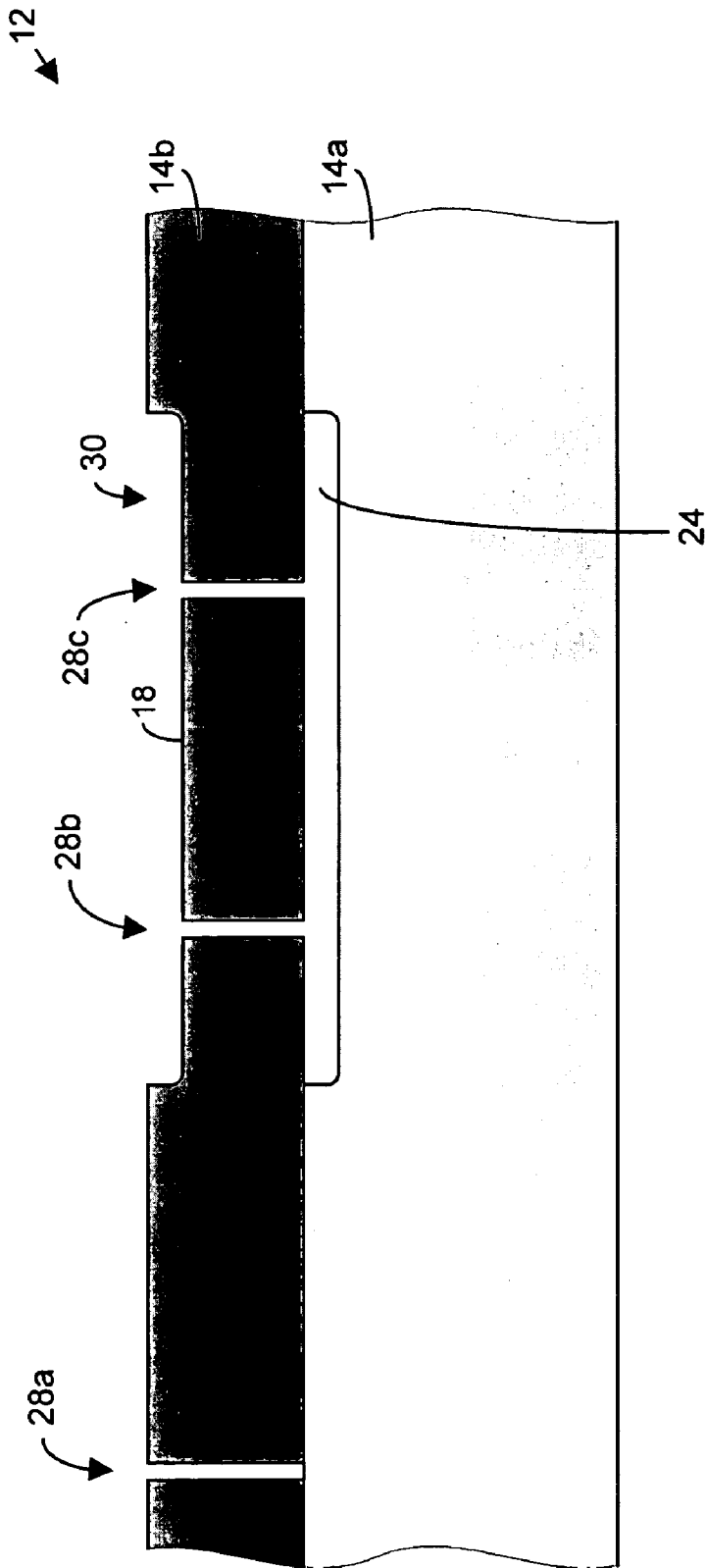

FIGURE 49E

10

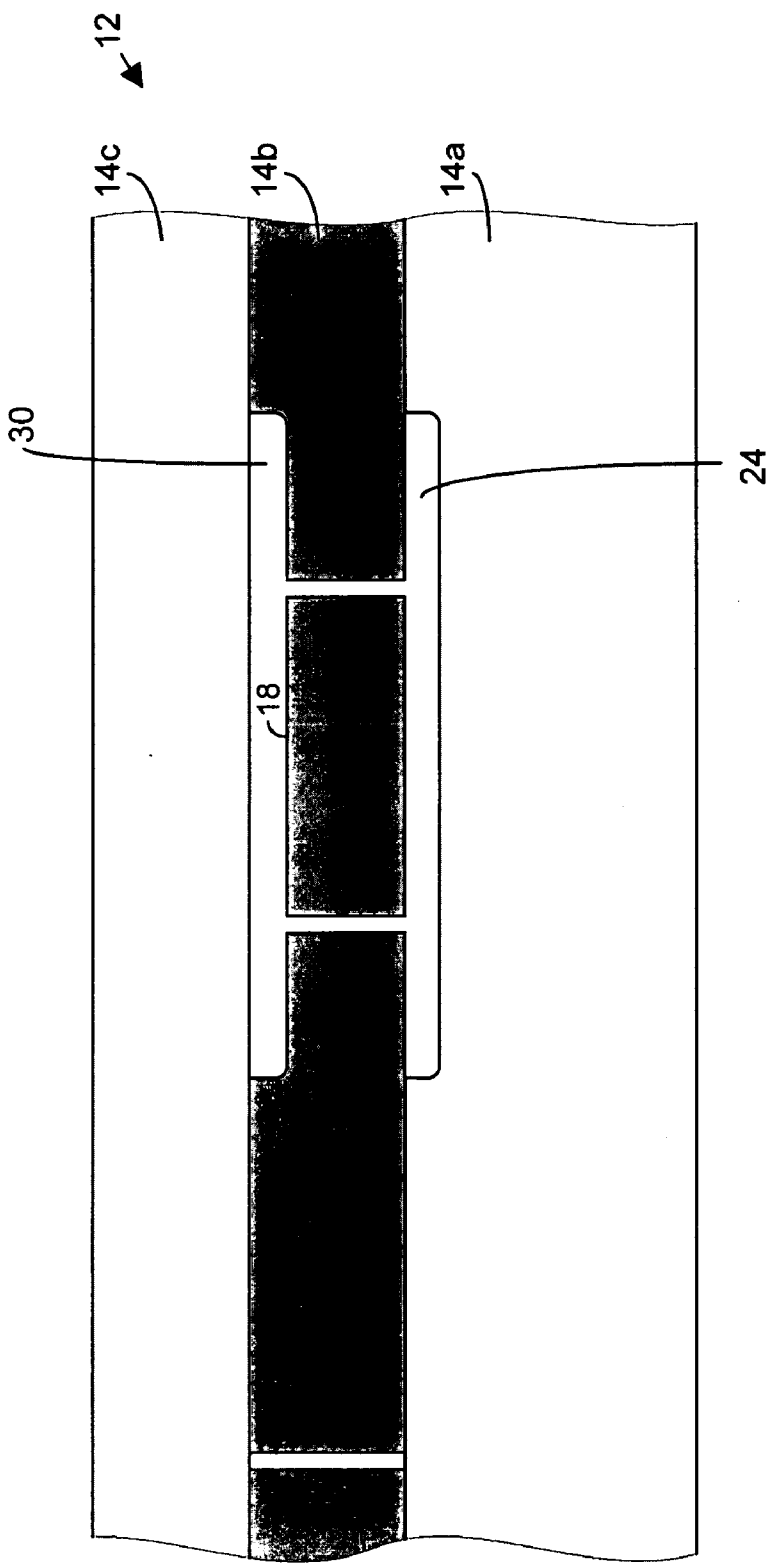

FIGURE 49F

10

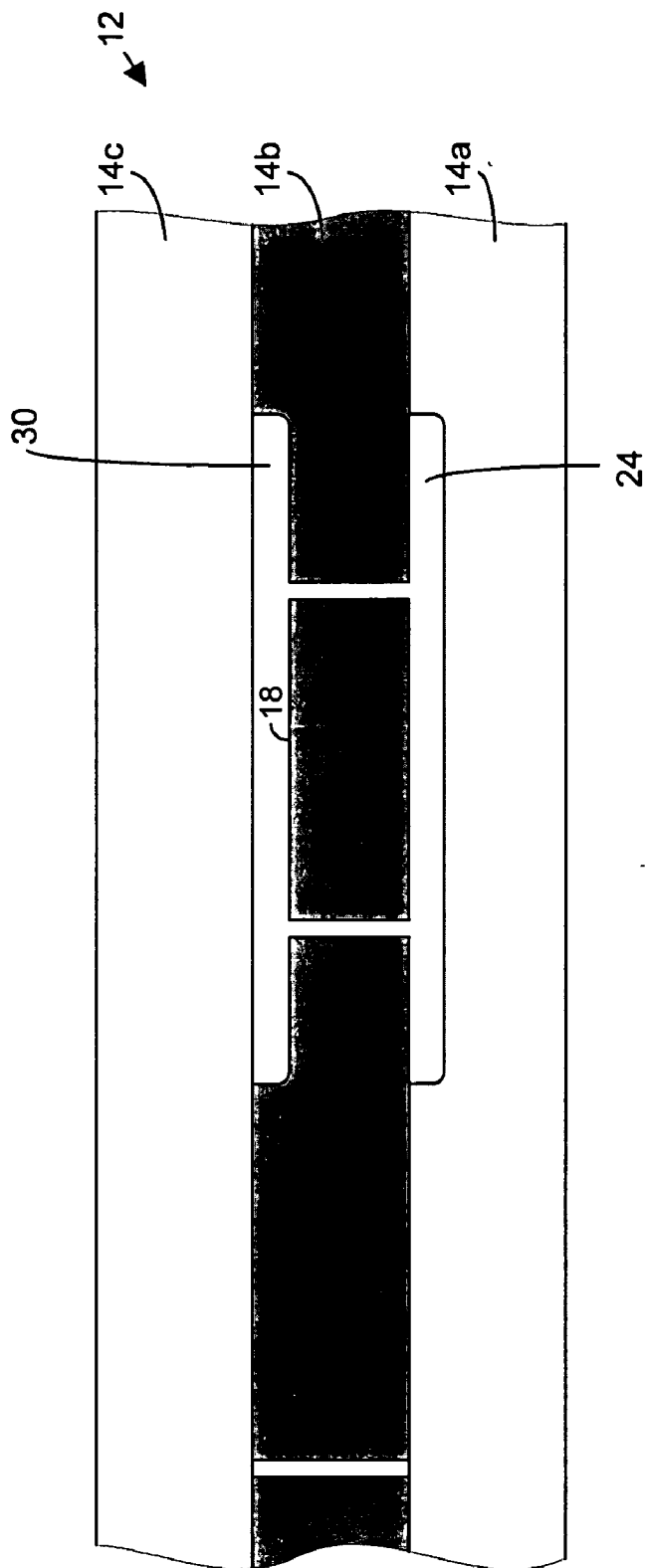
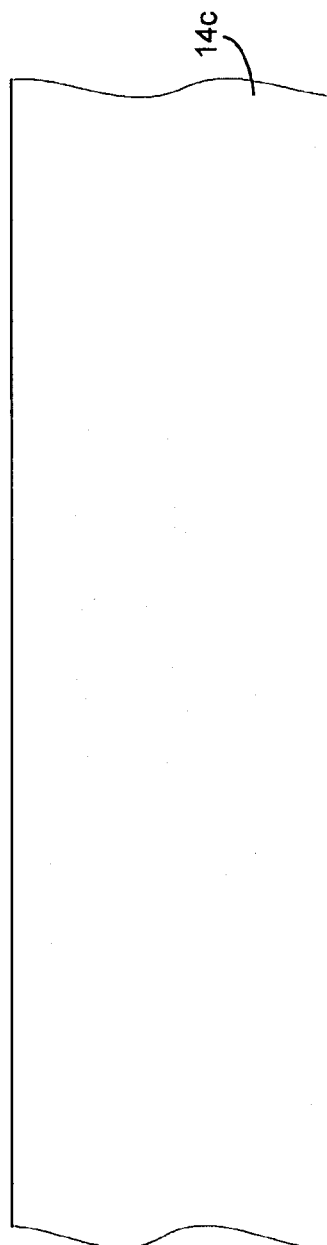
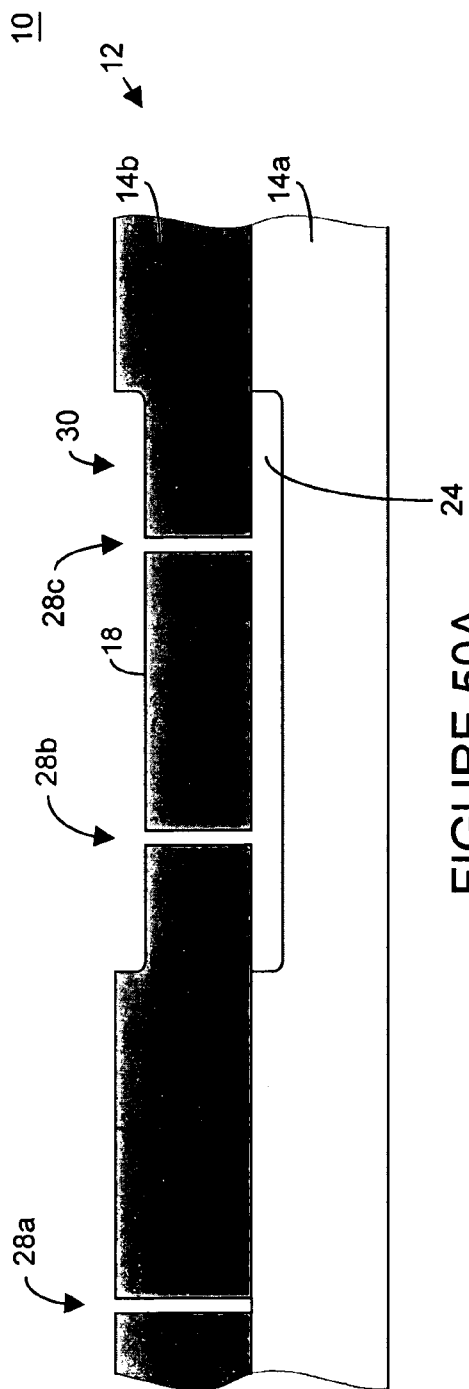

FIGURE 49G



10

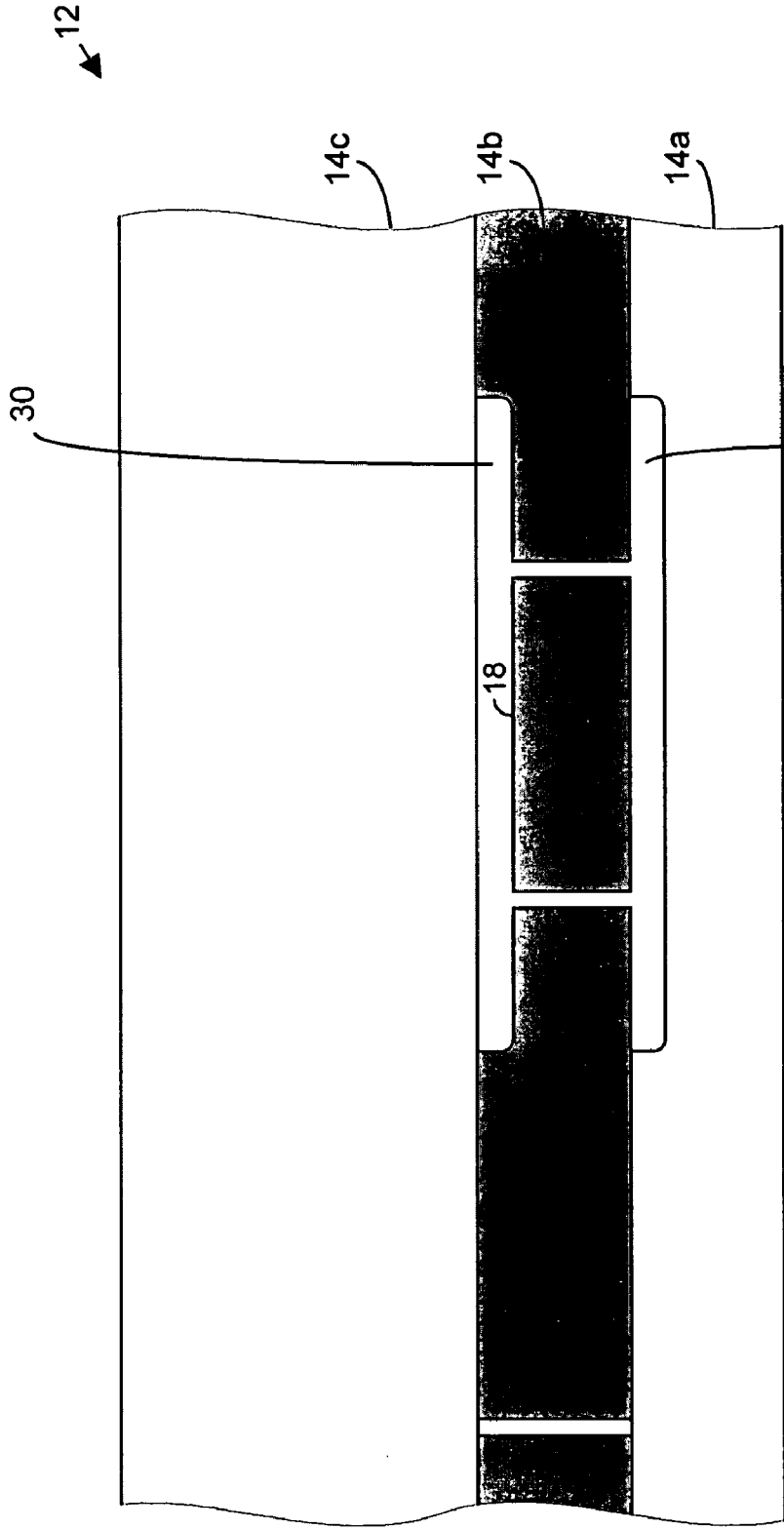

FIGURE 50C

10

12

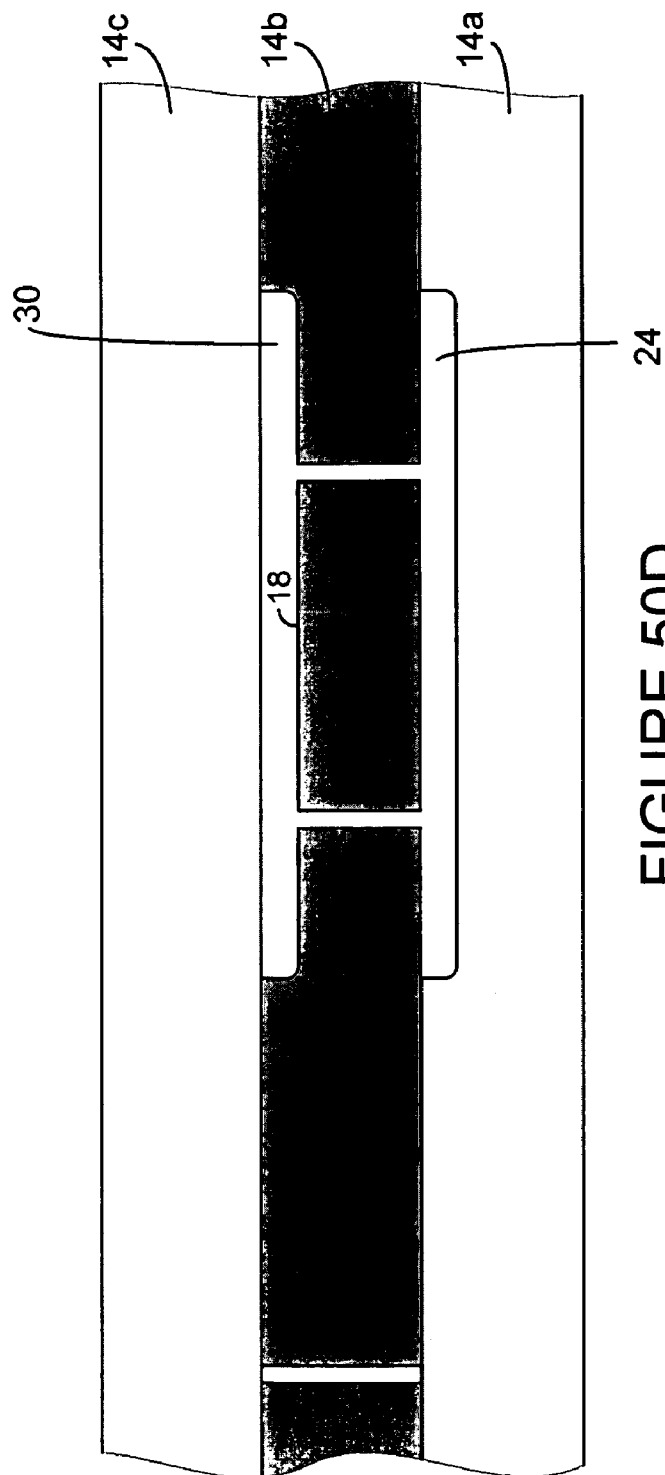

FIGURE 50D

10

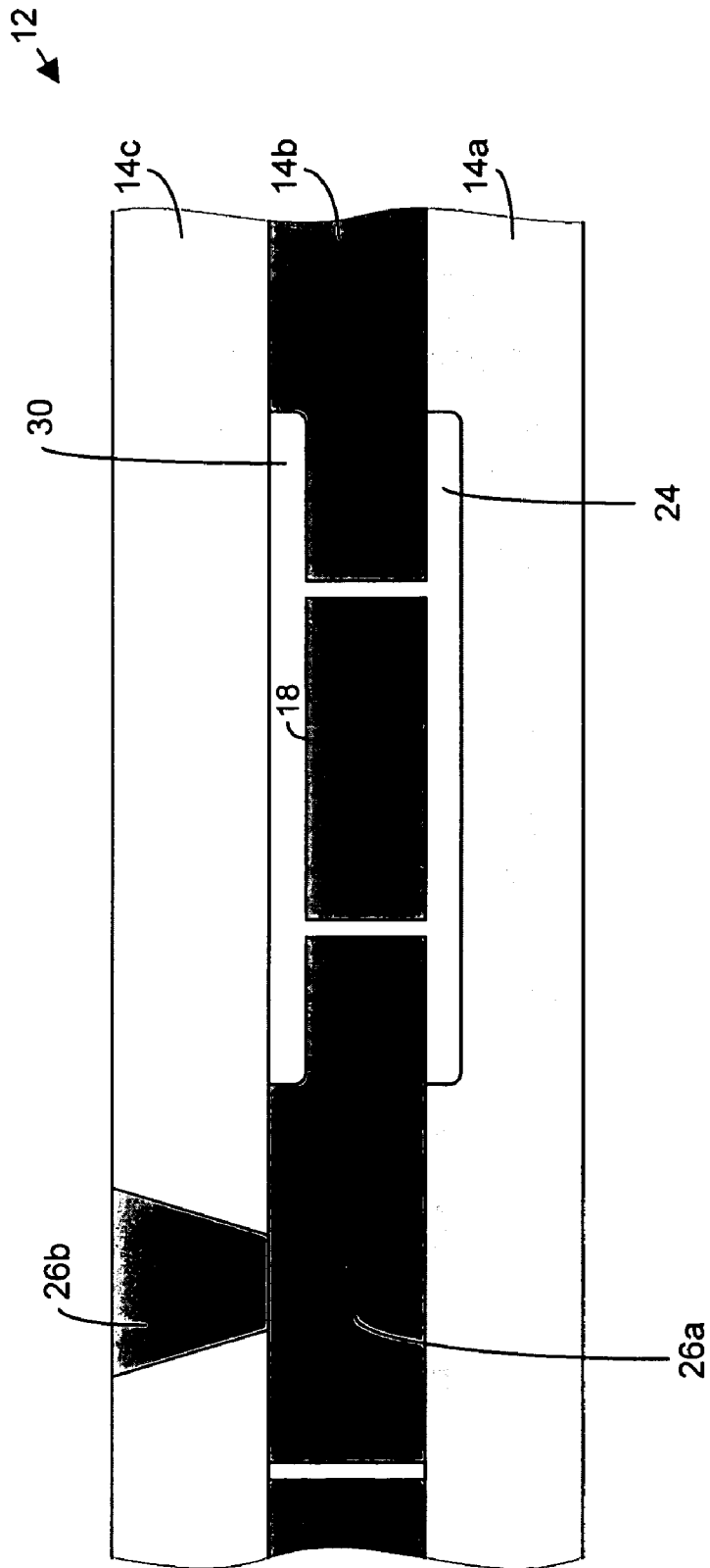

FIGURE 50E

10

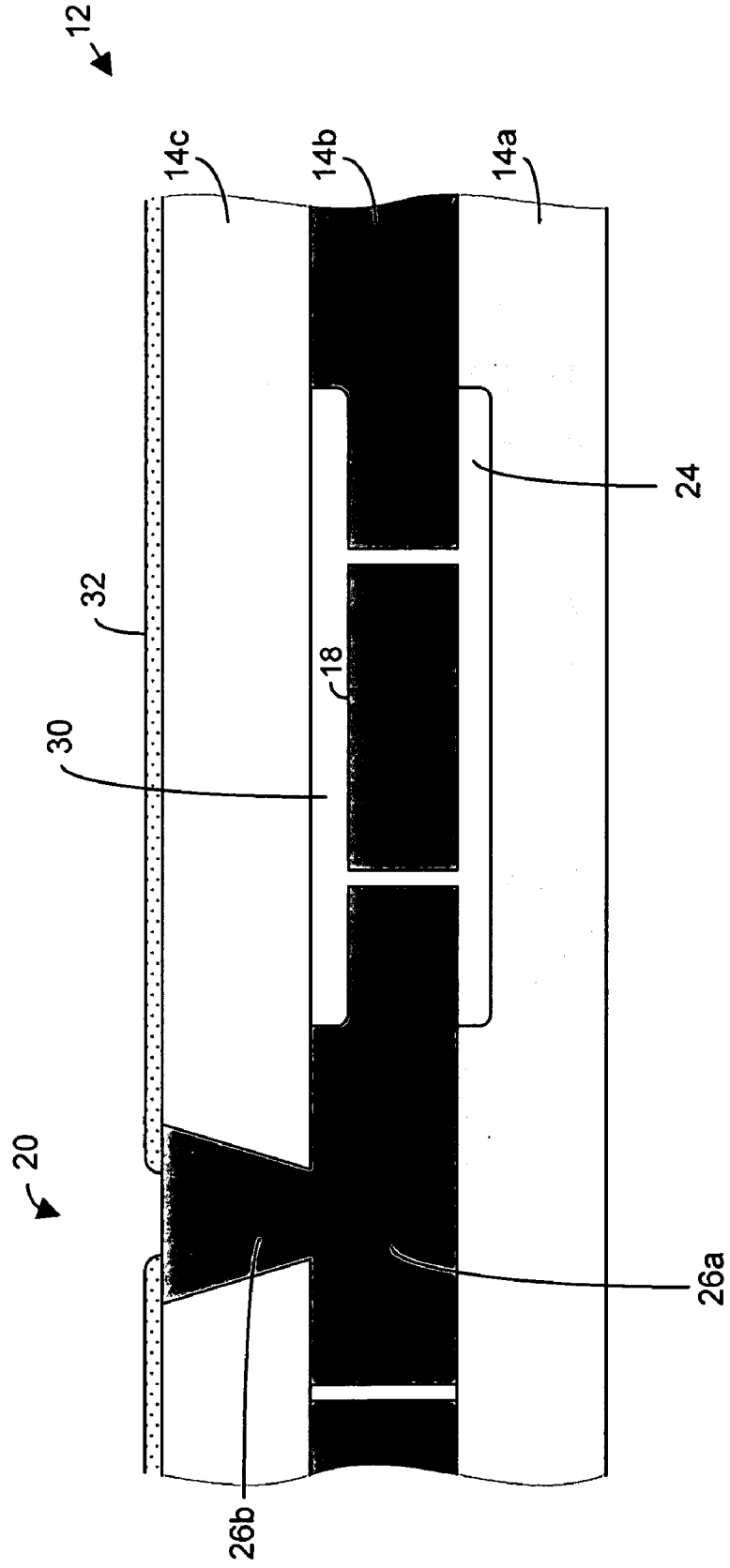

FIGURE 50F

10

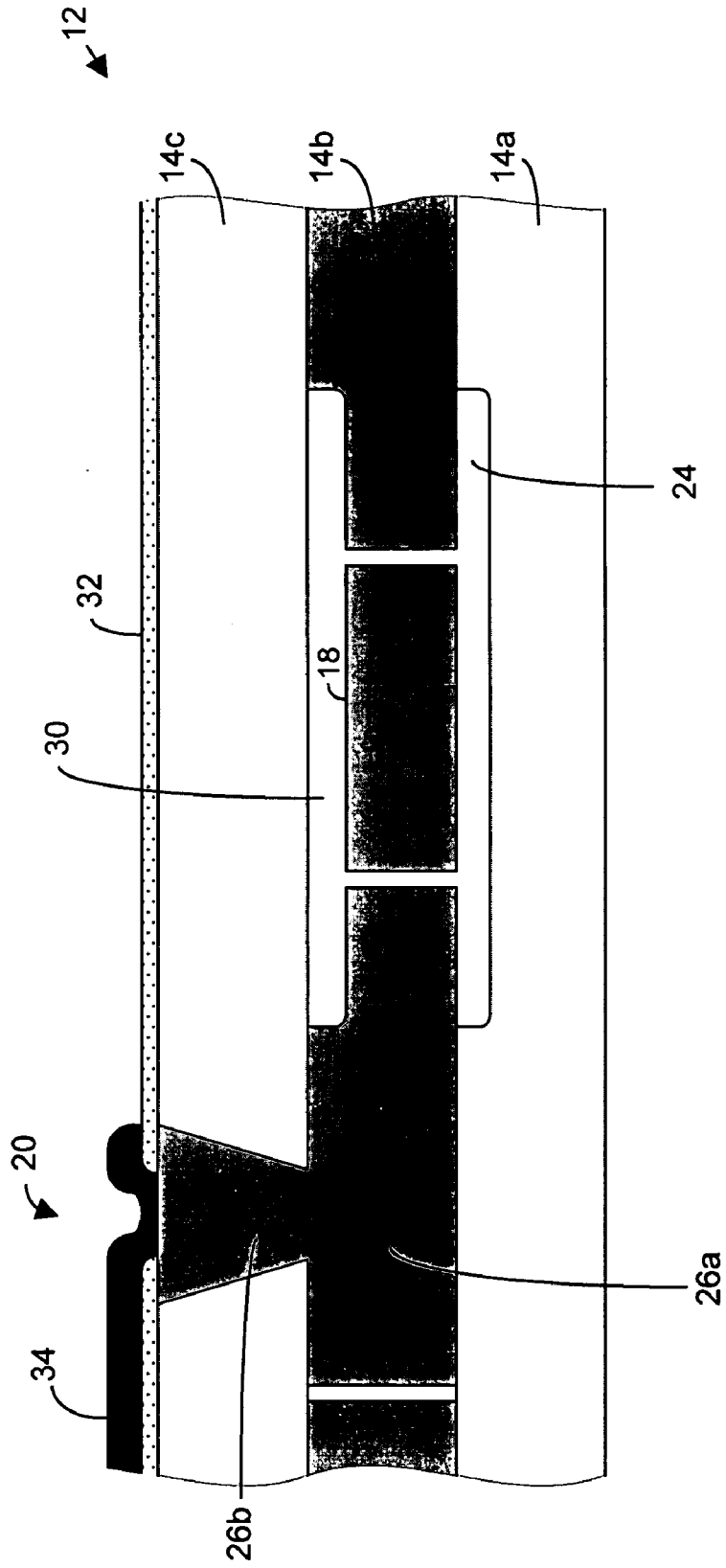

FIGURE 50G

10

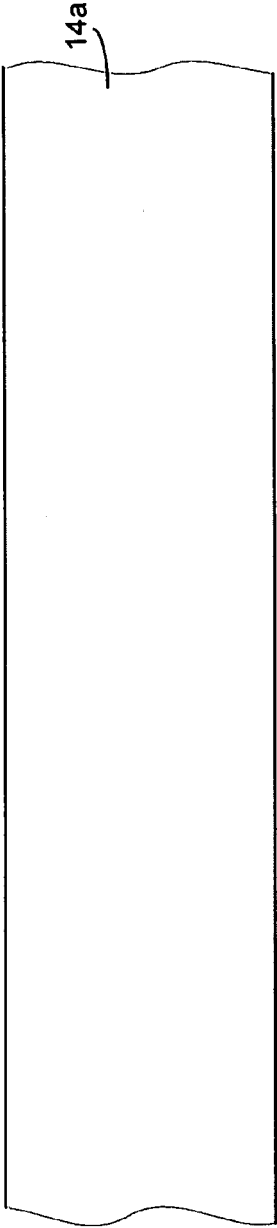

FIGURE 51A

10

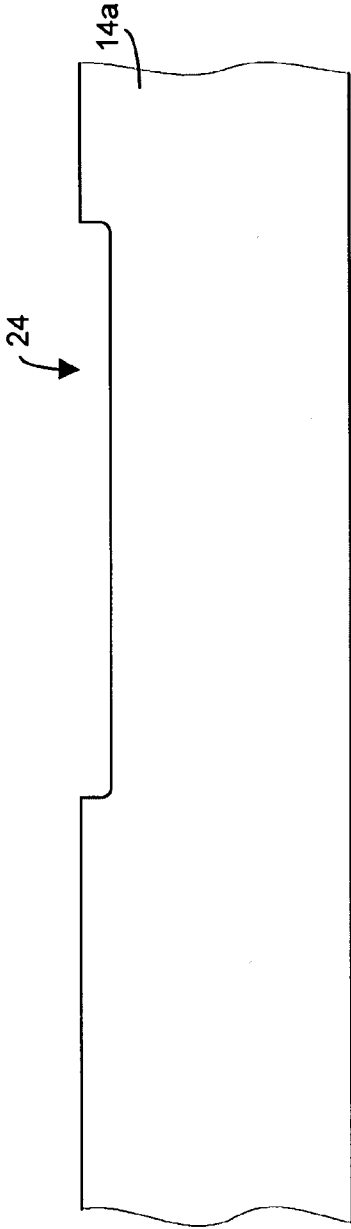

FIGURE 51B

10

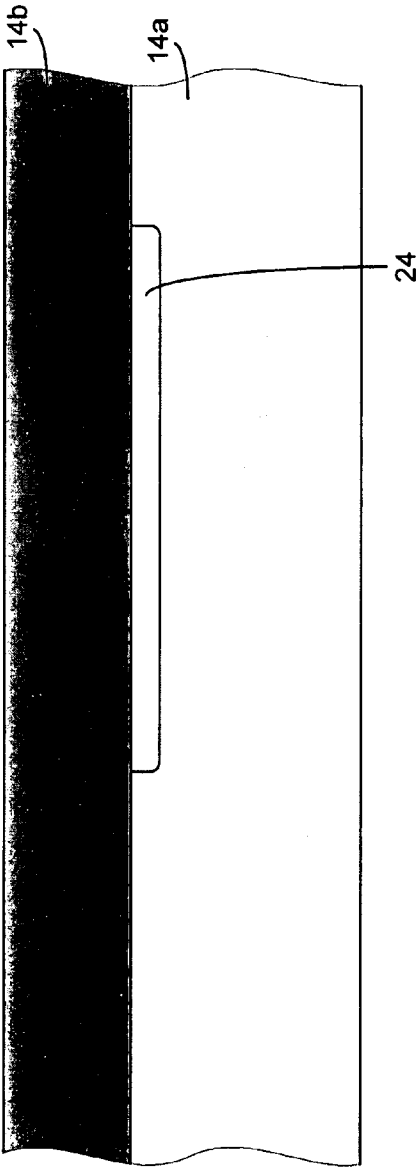

FIGURE 51C

10

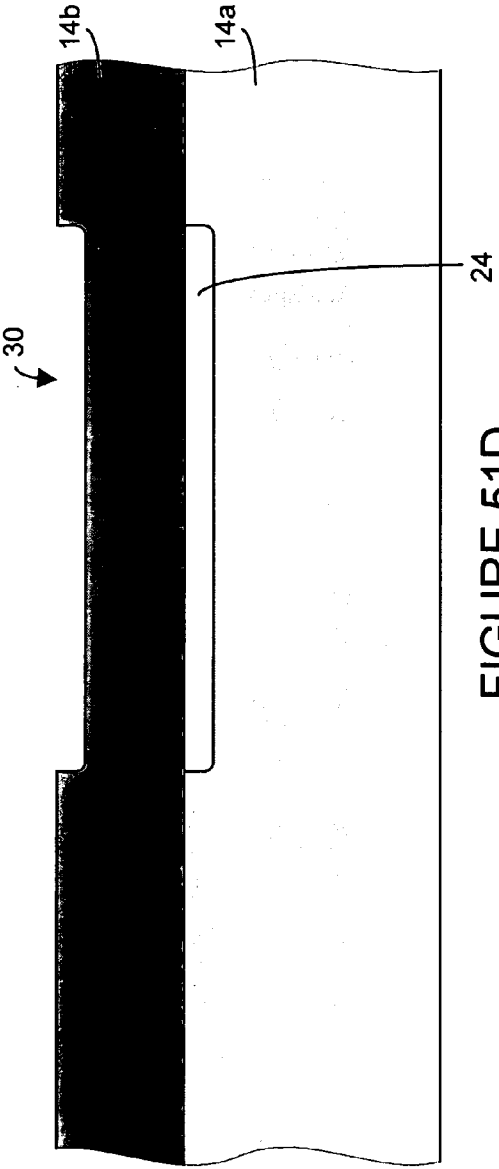

FIGURE 51D

10

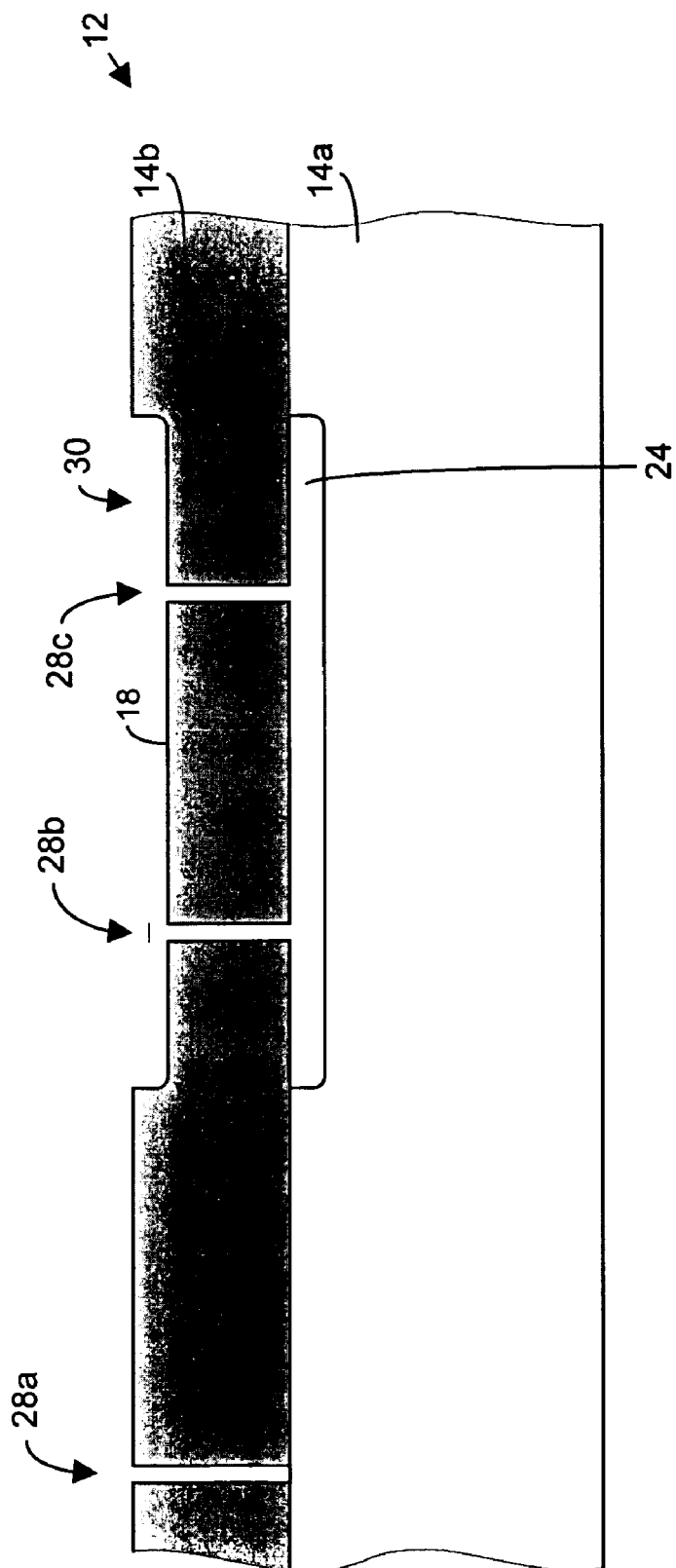

FIGURE 51E

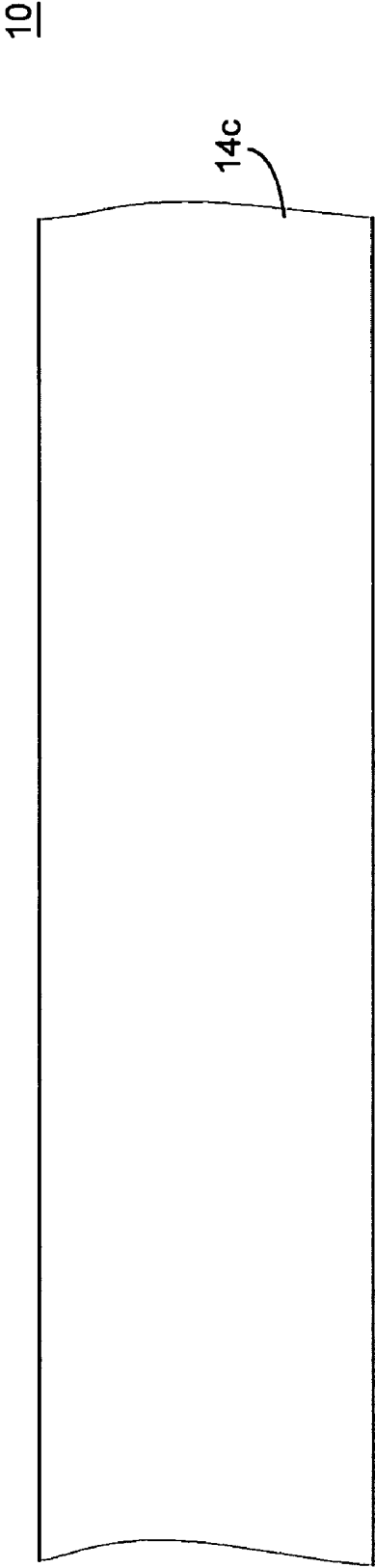

FIGURE 51F

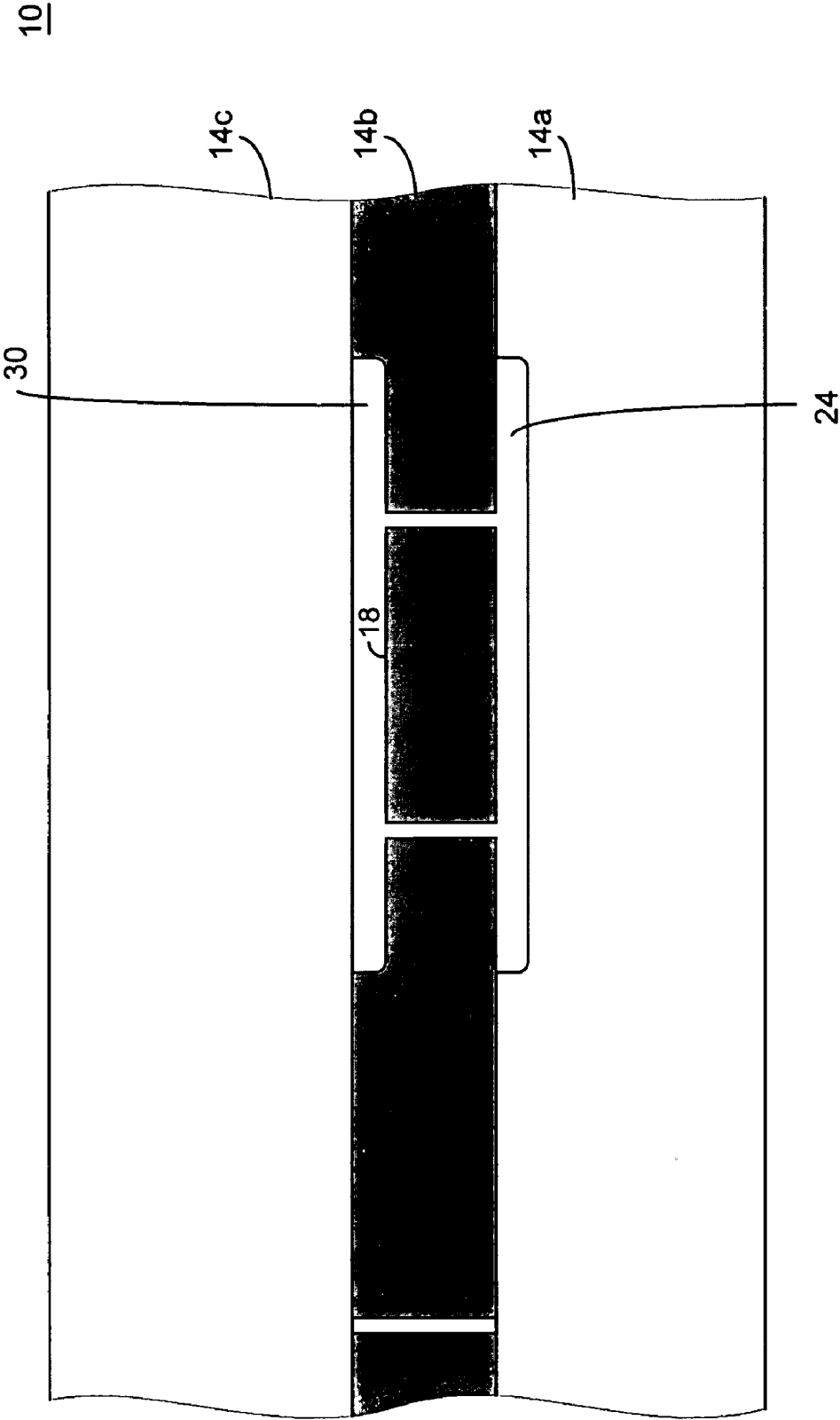

FIGURE 51G

10

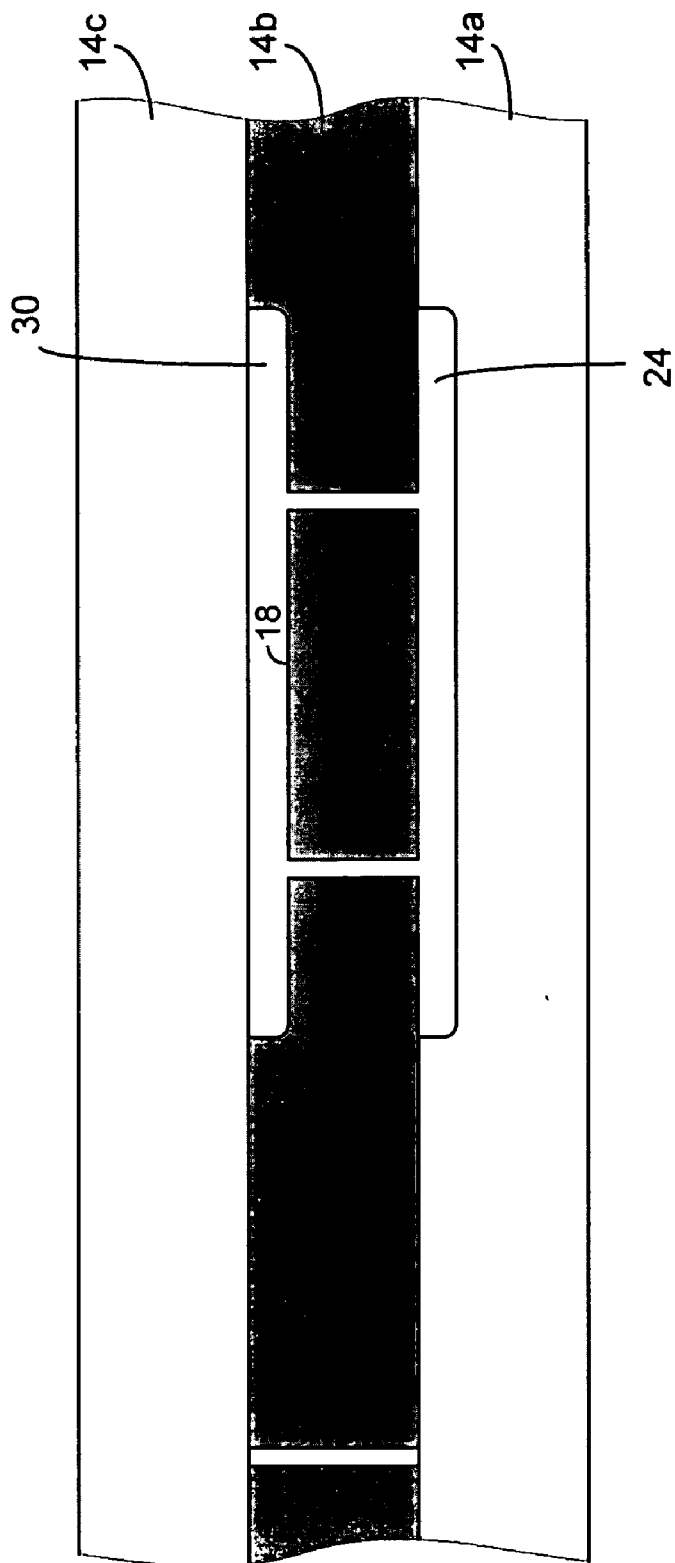

FIGURE 51H

10

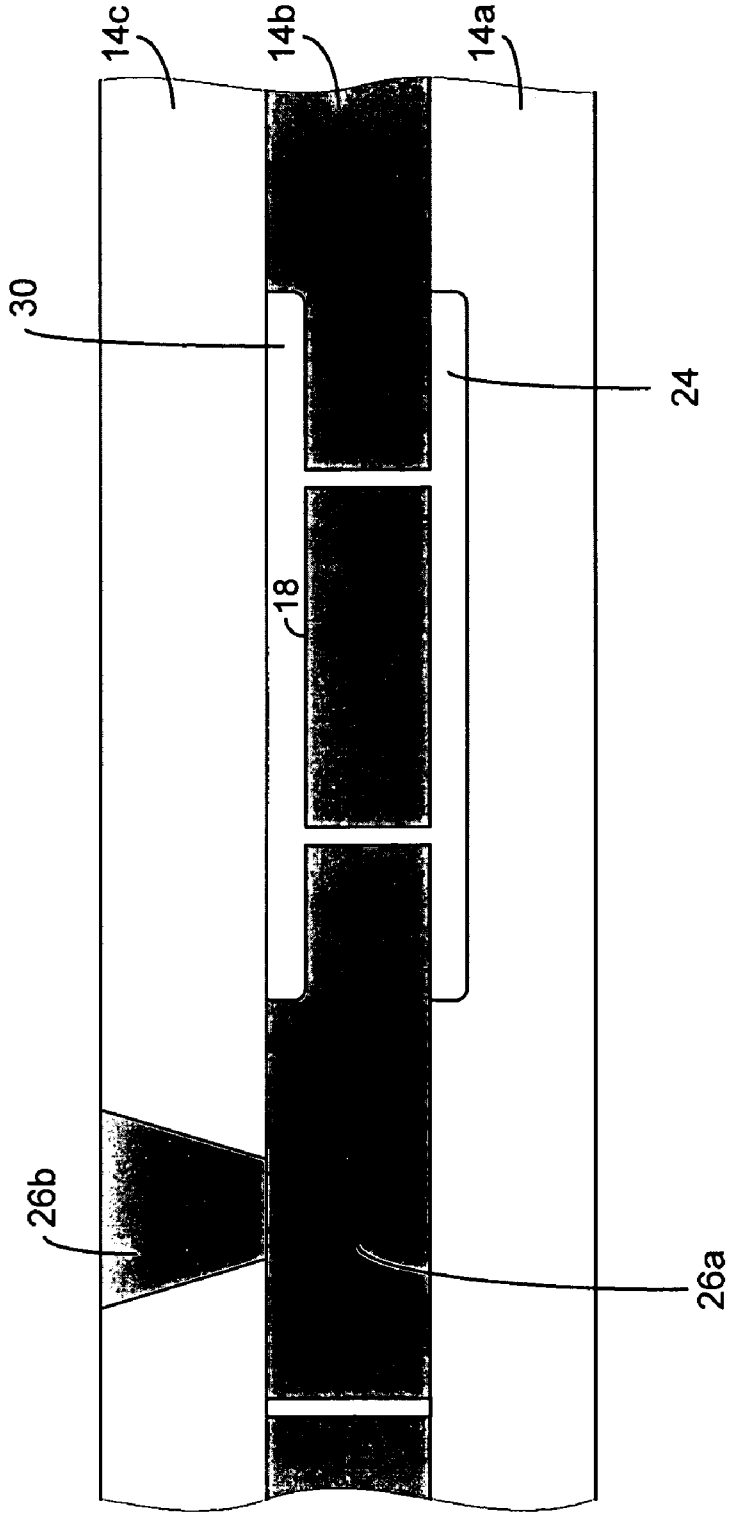

FIGURE 51I

10

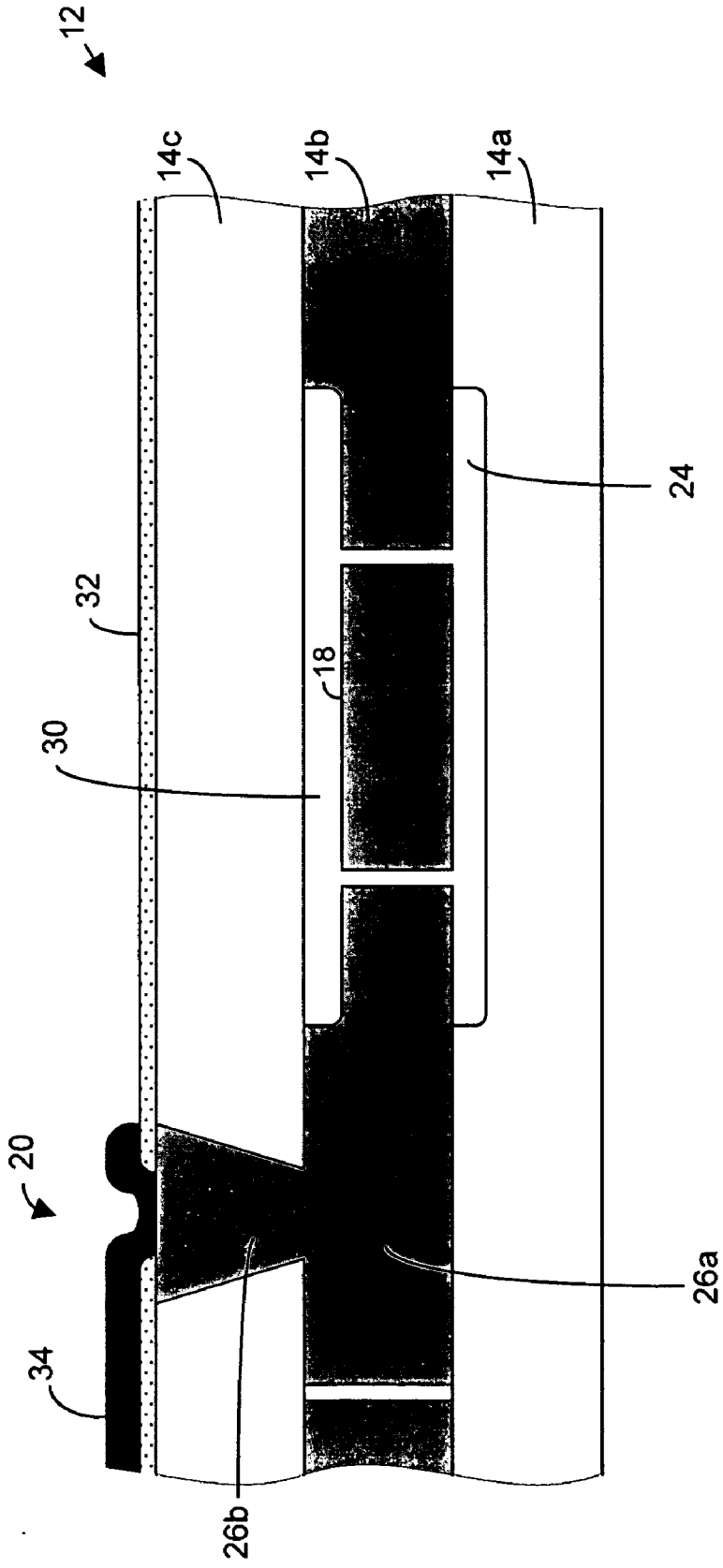

FIGURE 51J

10

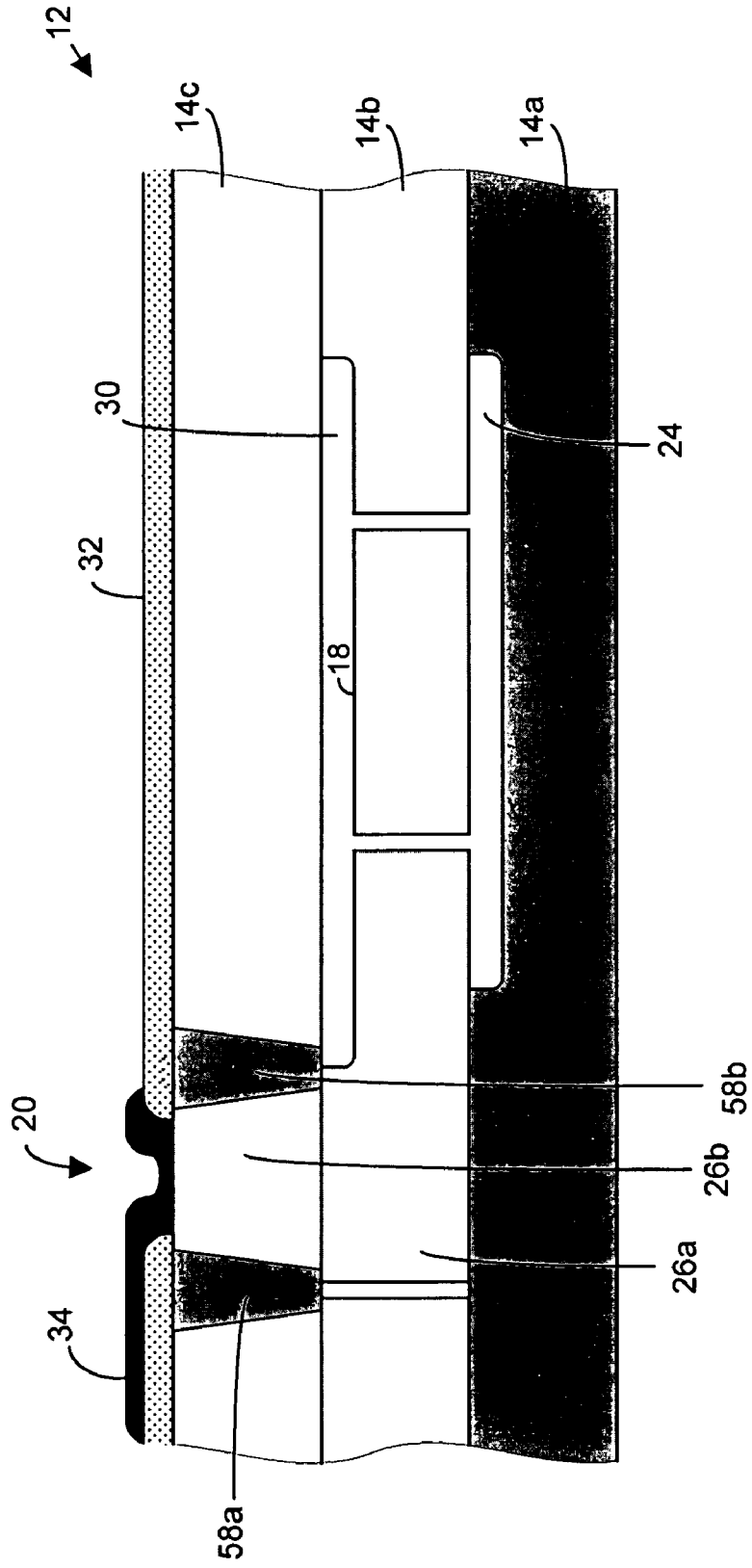

FIGURE 52



FIGURE 53A

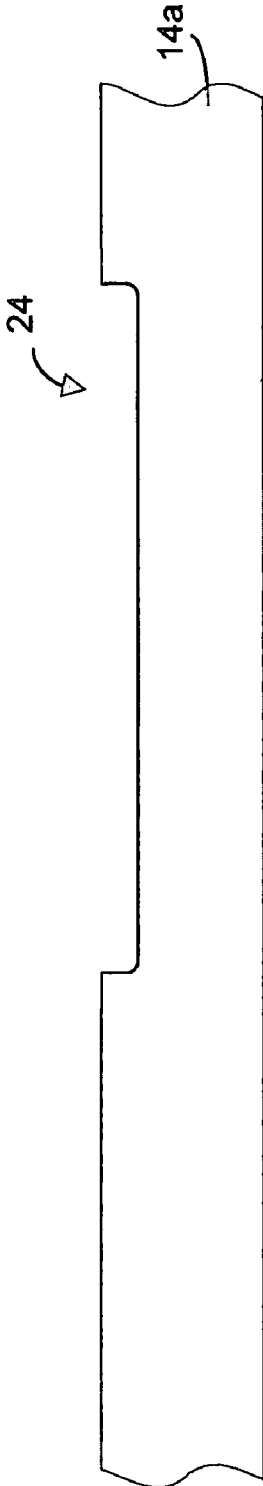

FIGURE 53B

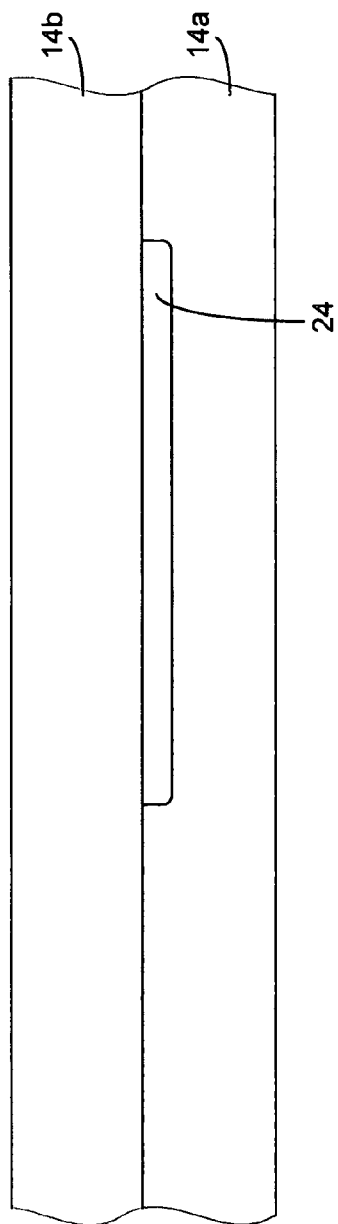

FIGURE 53C

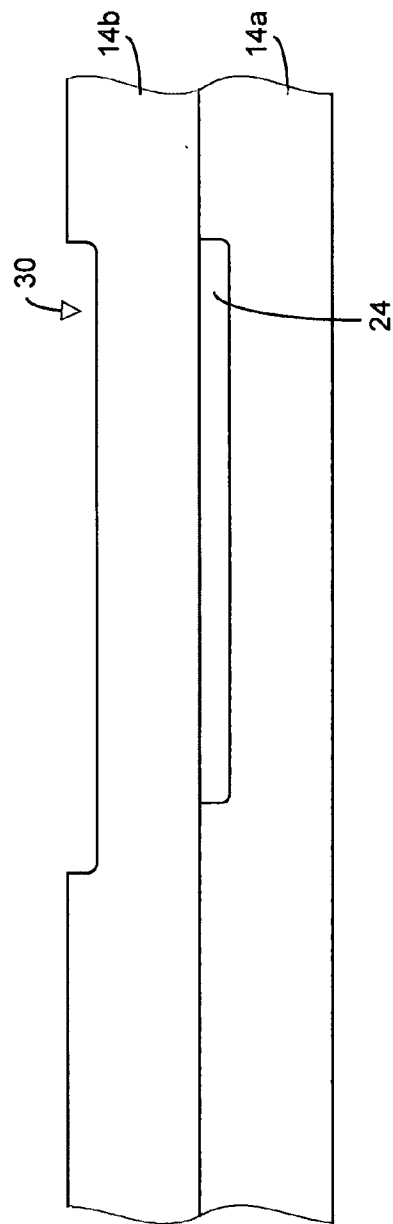

FIGURE 53D

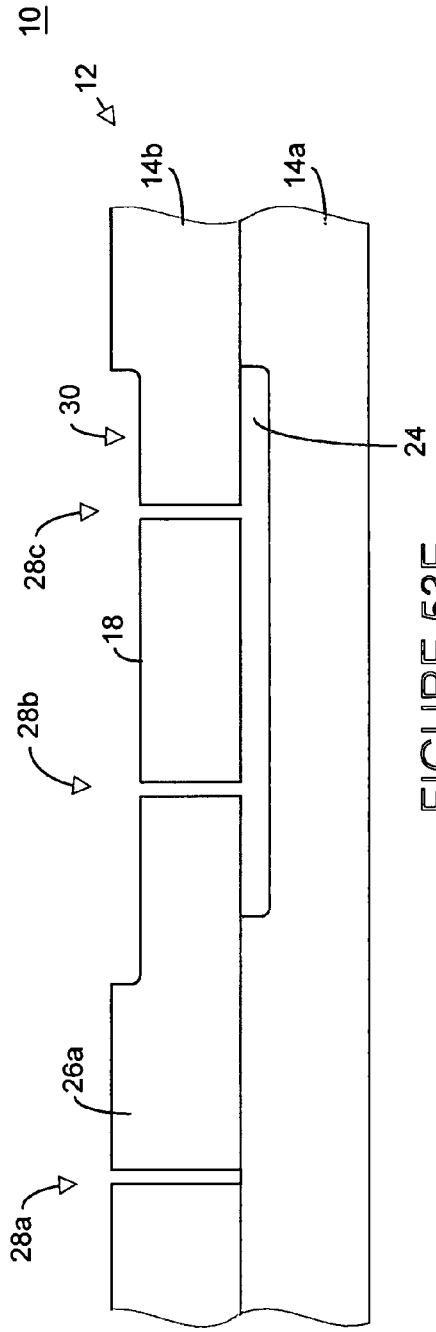

FIGURE 53E

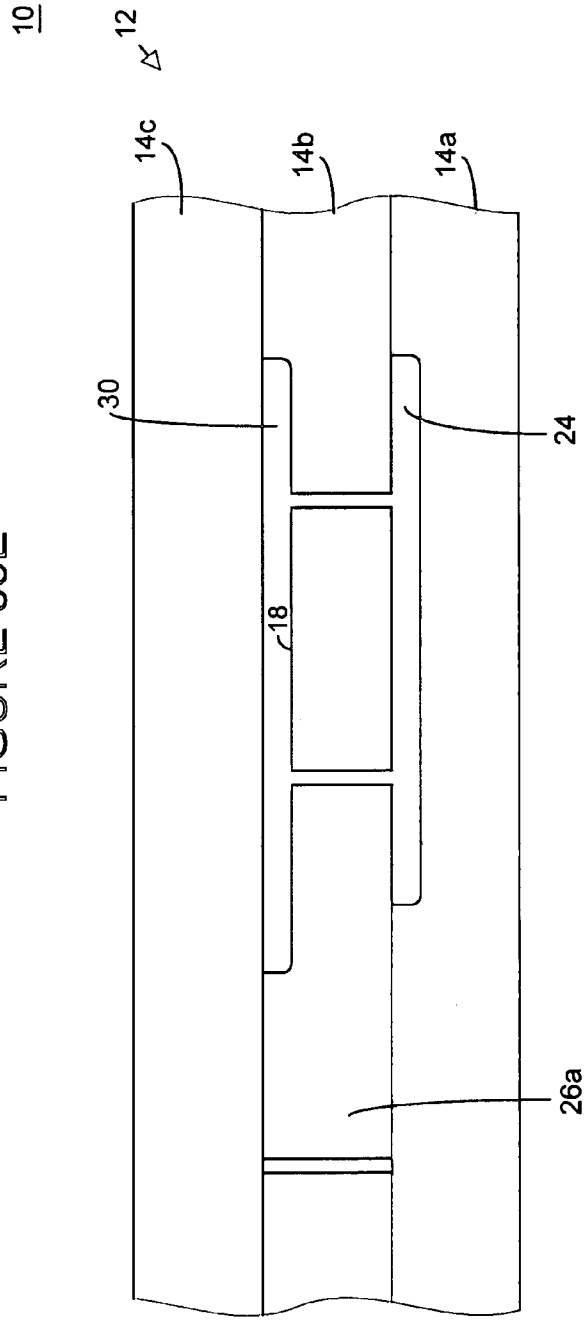

FIGURE 53F

10

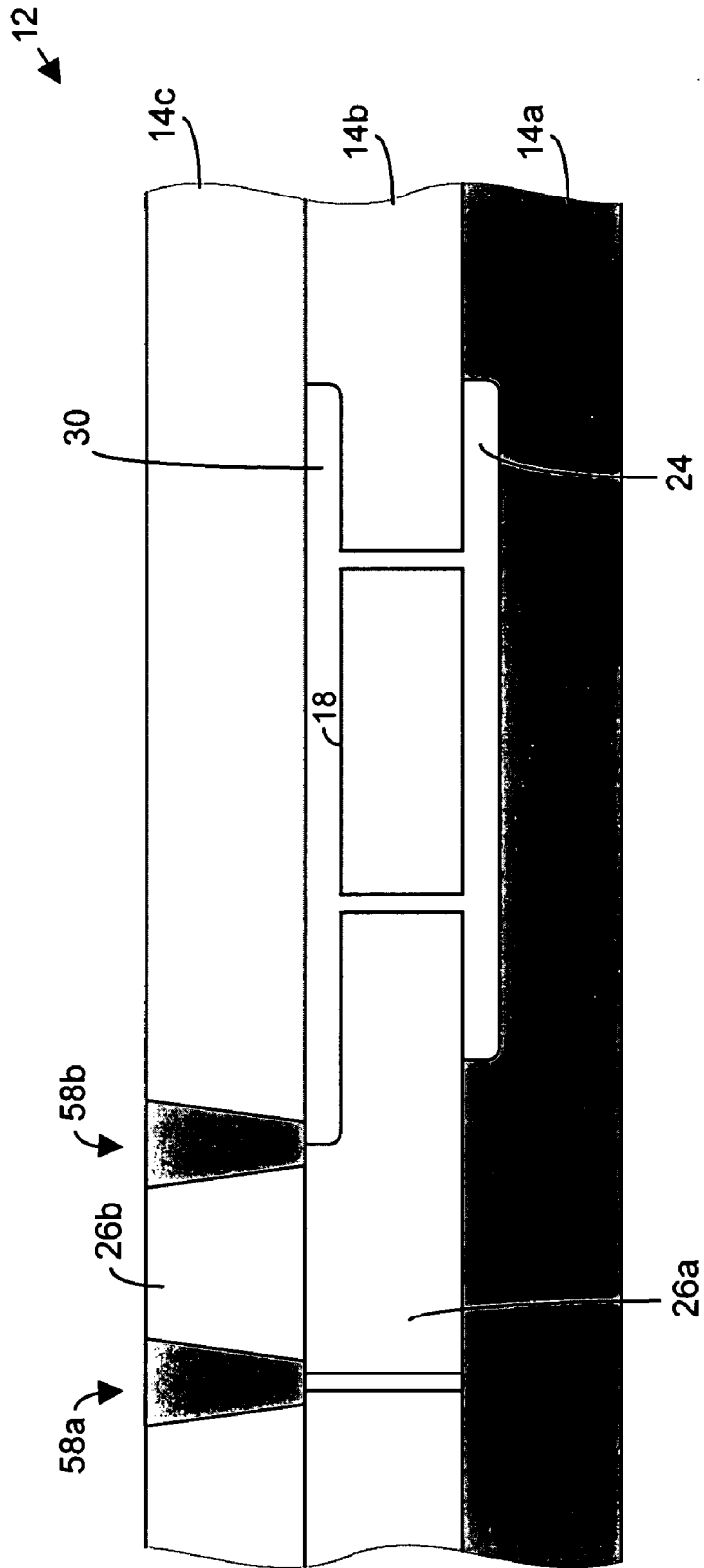

FIGURE 53G

10

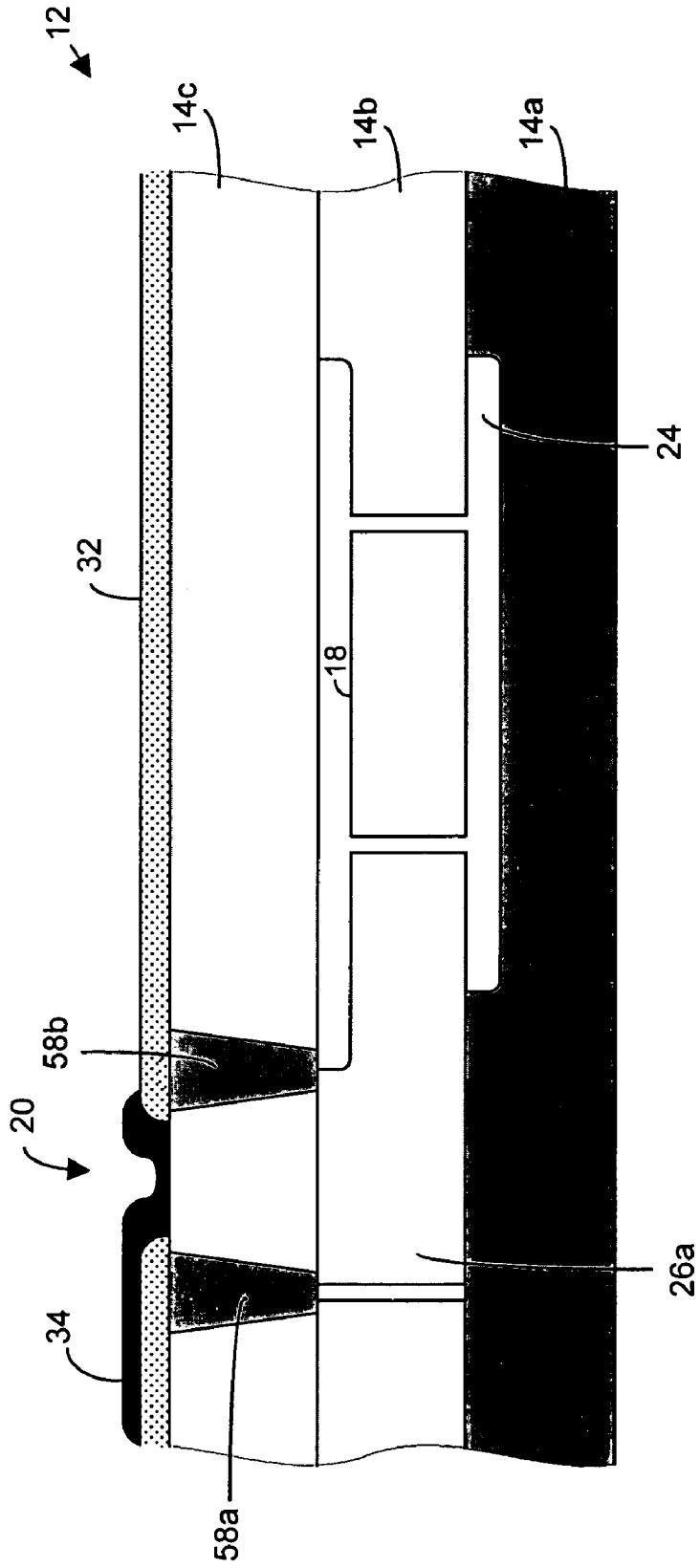

FIGURE 53H

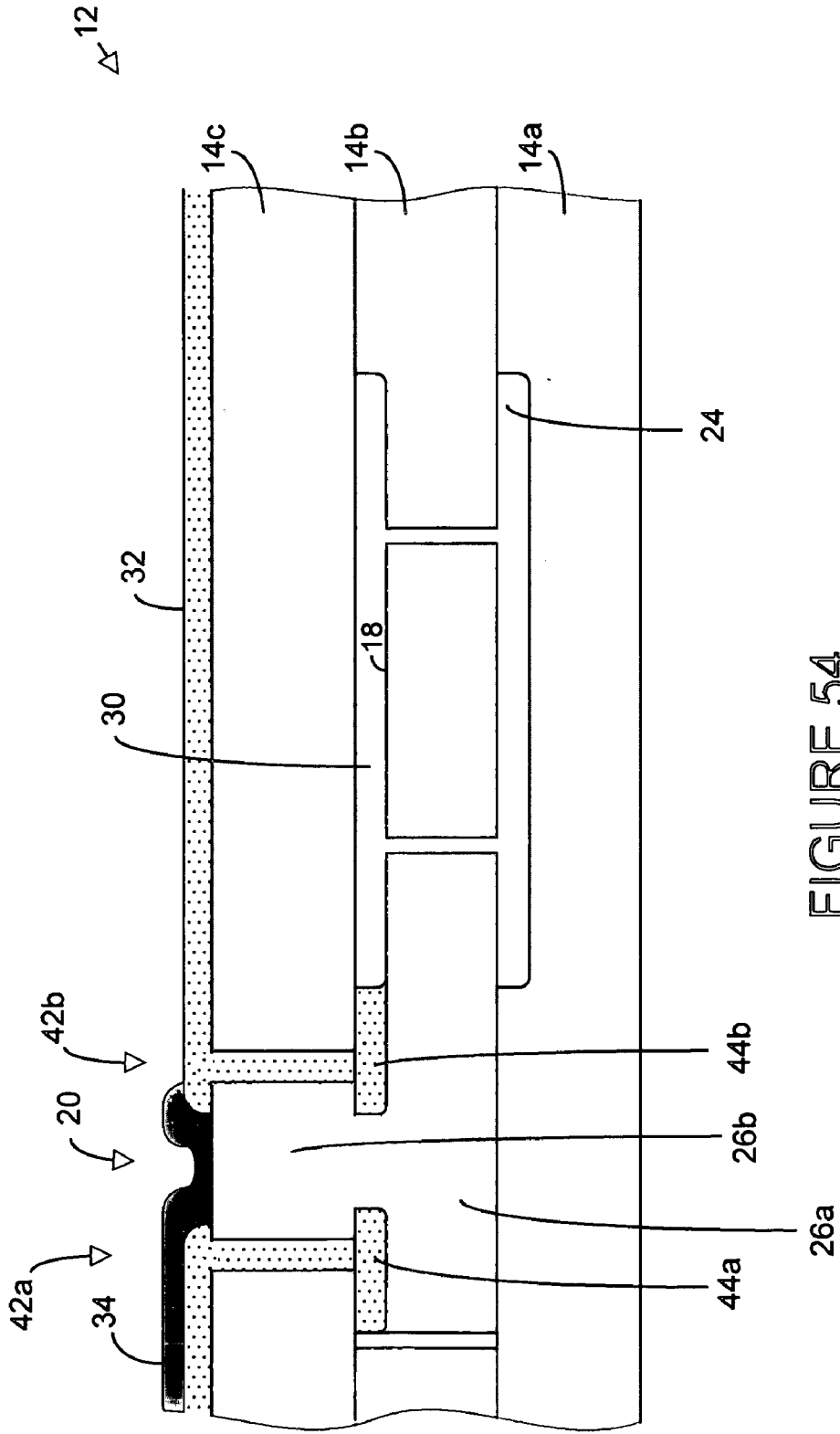

FIGURE 54



FIGURE 55A

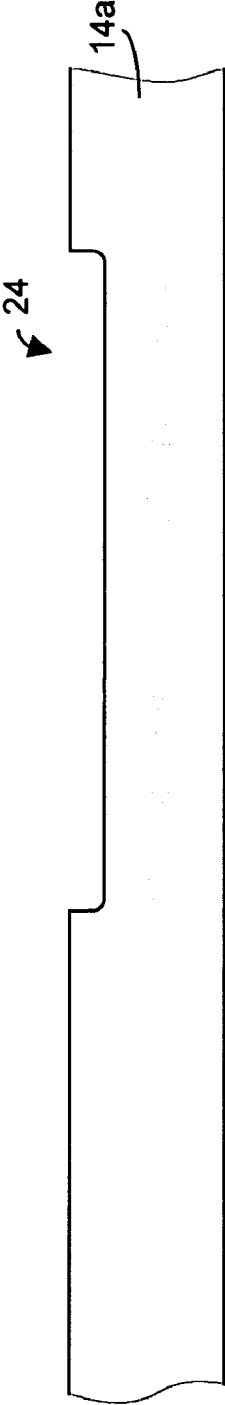

FIGURE 55B

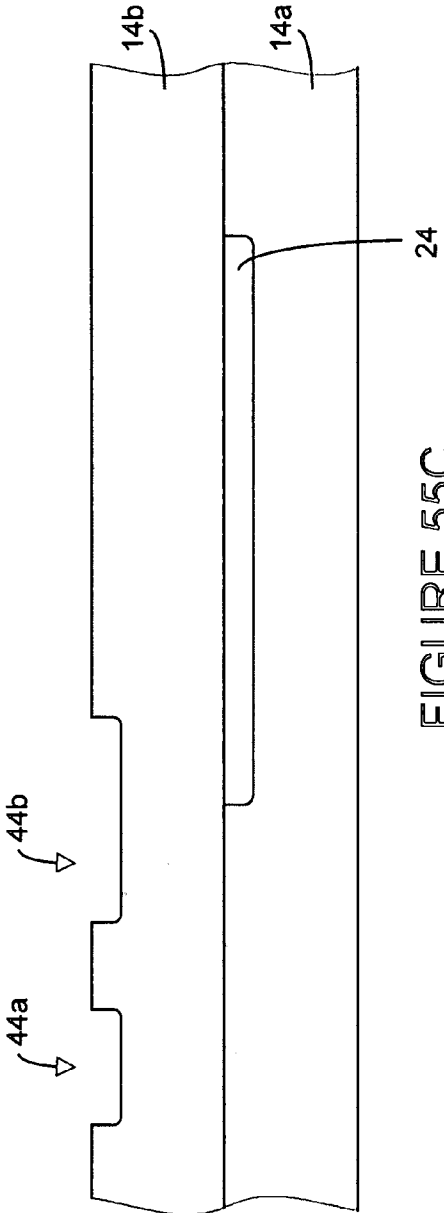

FIGURE 55C

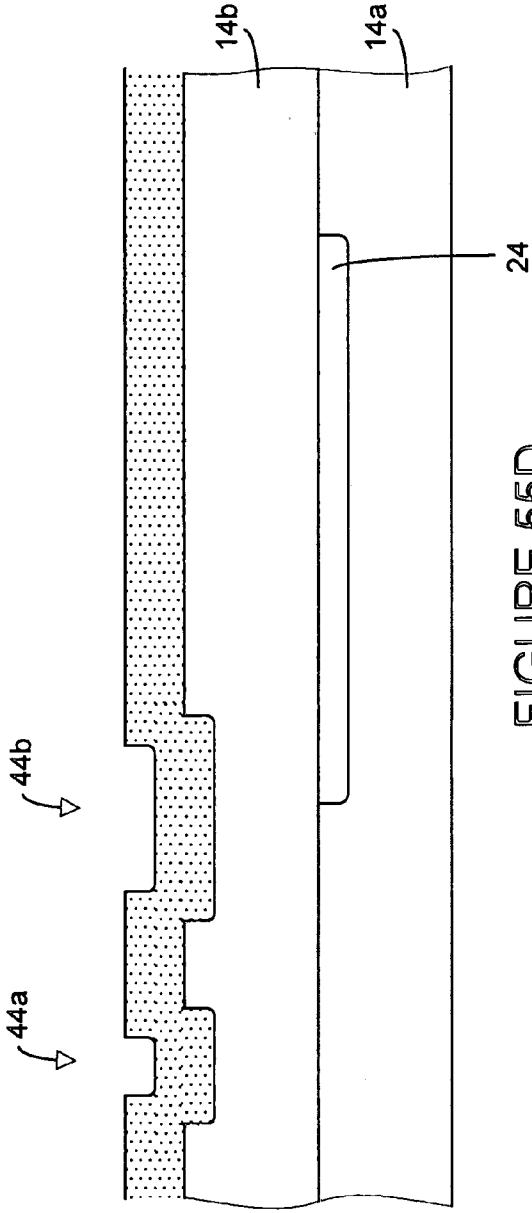

FIGURE 55D

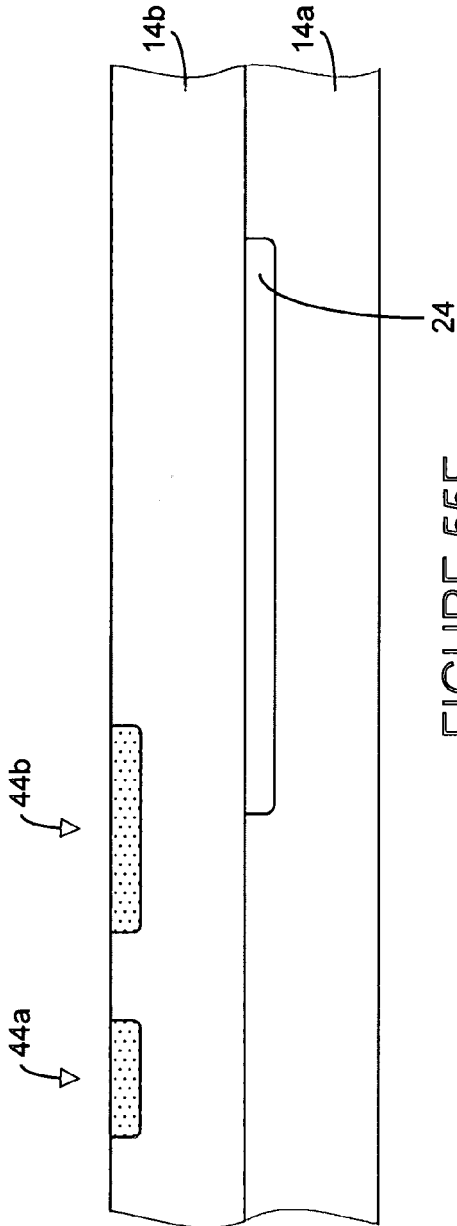

FIGURE 55E

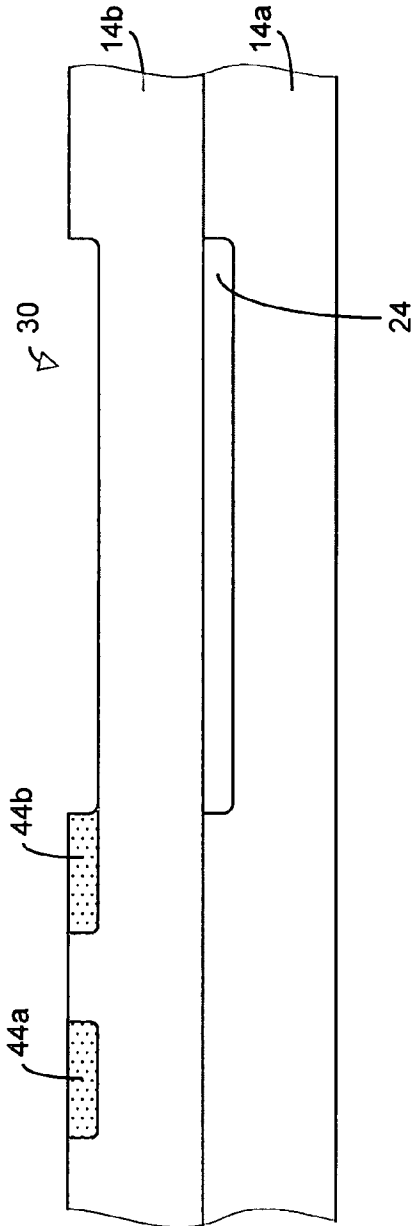

FIGURE 55F

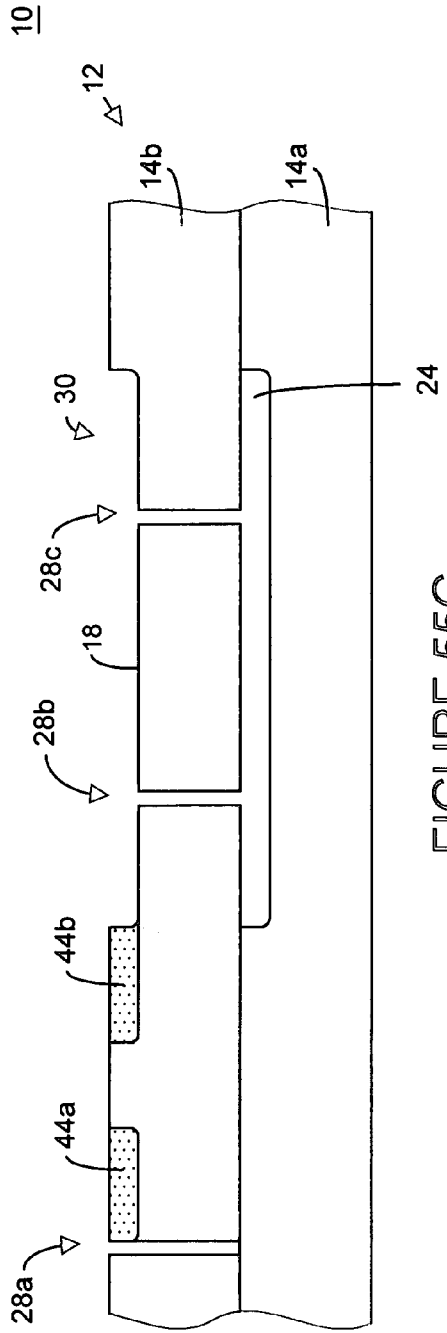

FIGURE 55G

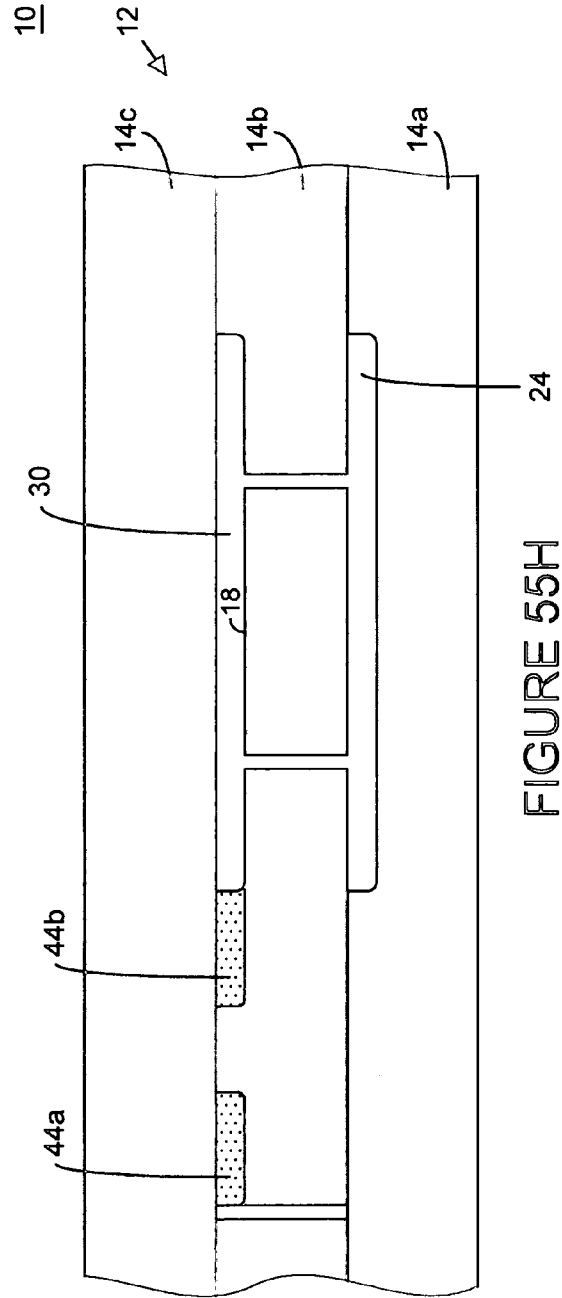

FIGURE 55H

10

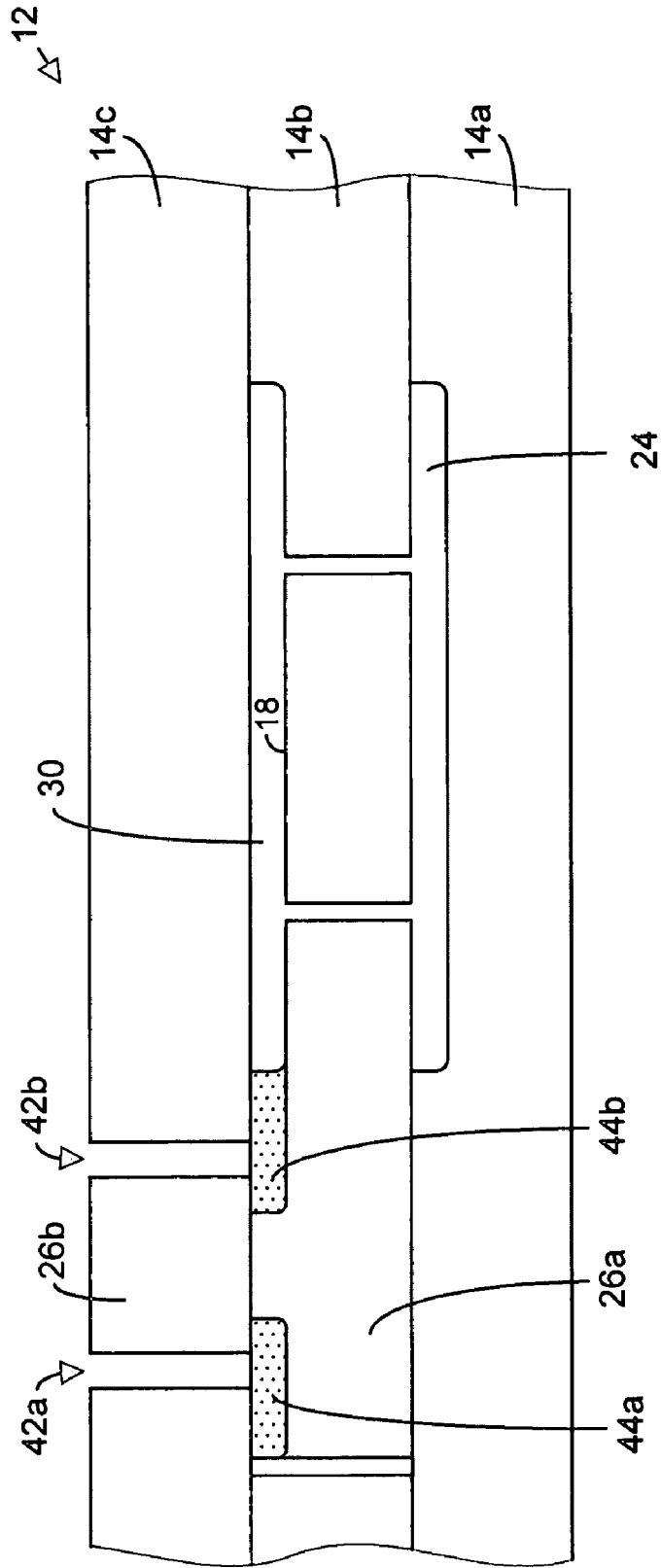

FIGURE 55I

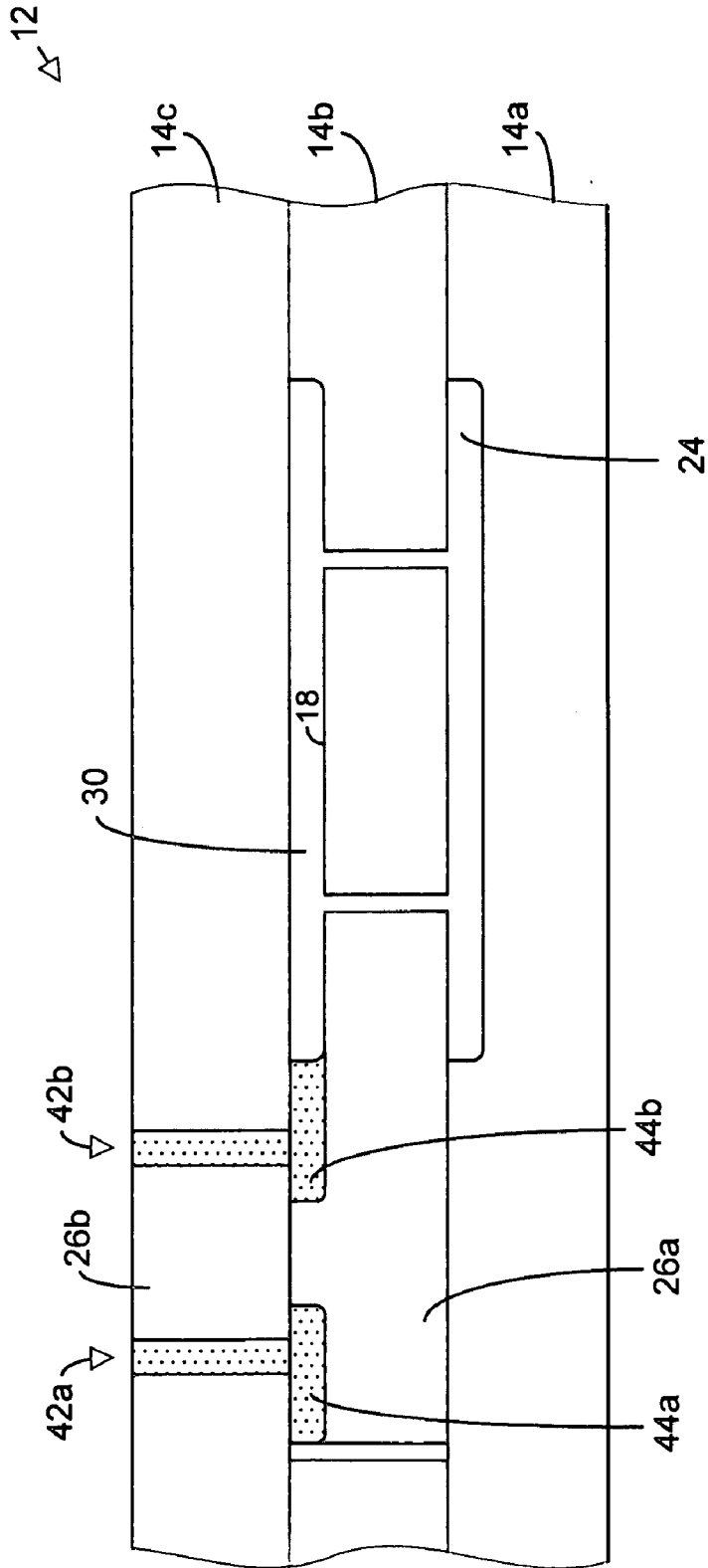

FIGURE 55J

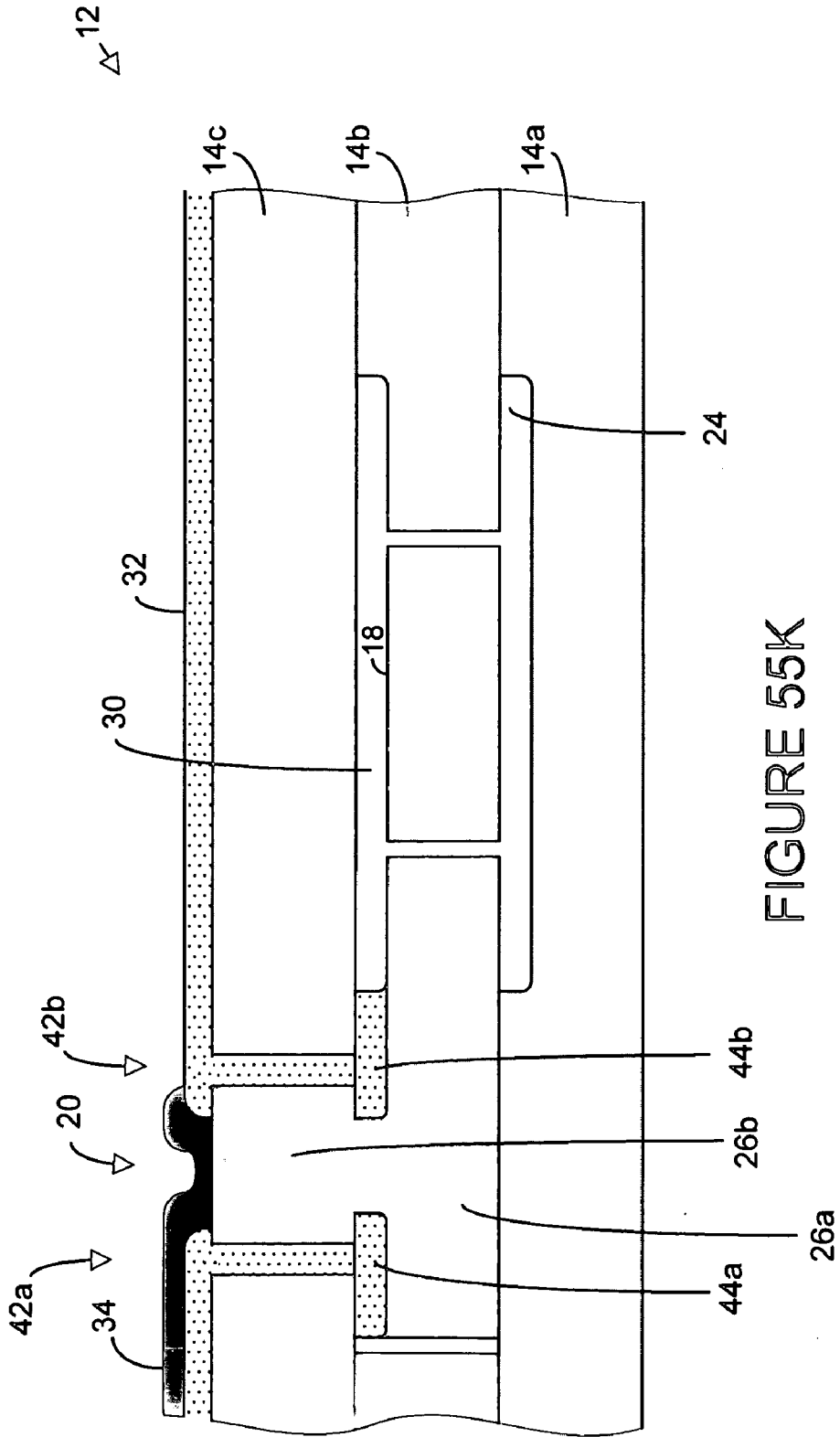

FIGURE 55K

10

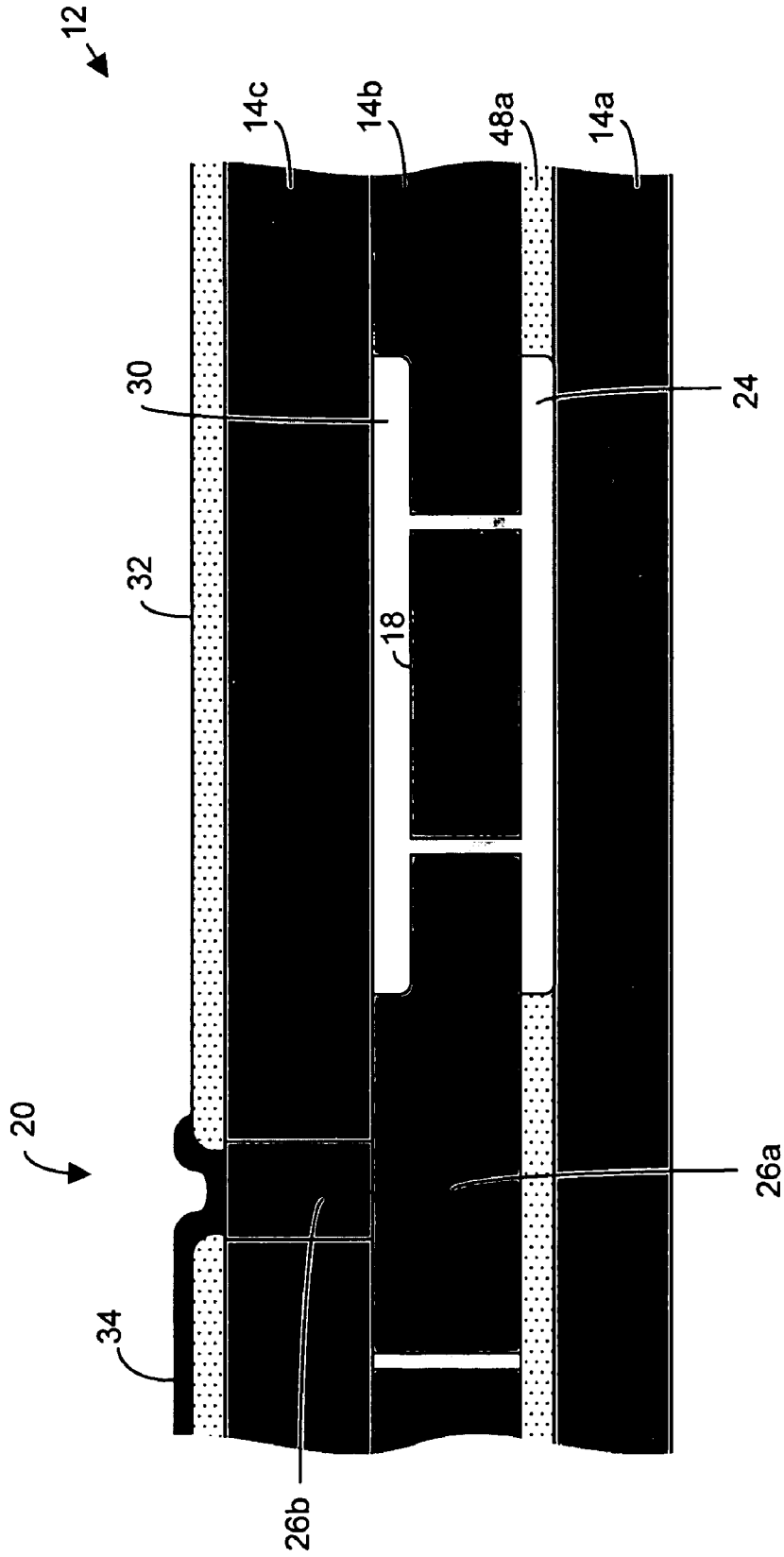

FIGURE 56

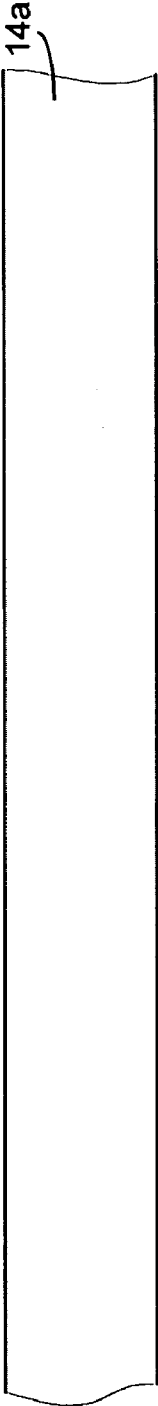

FIGURE 57A

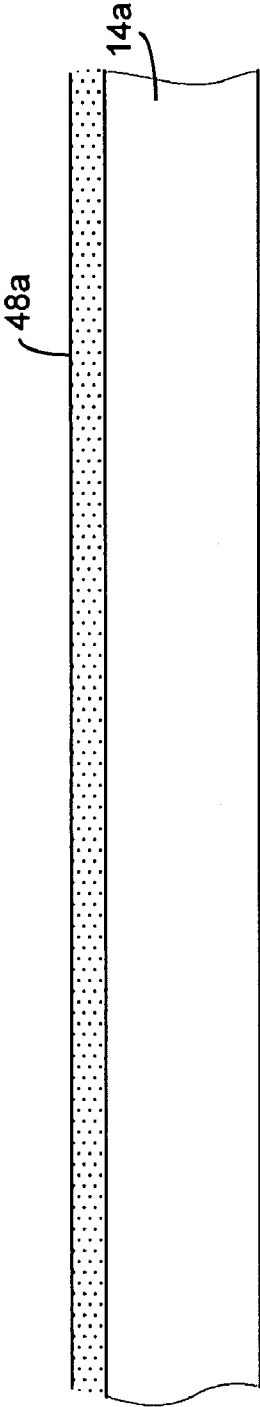

FIGURE 57B

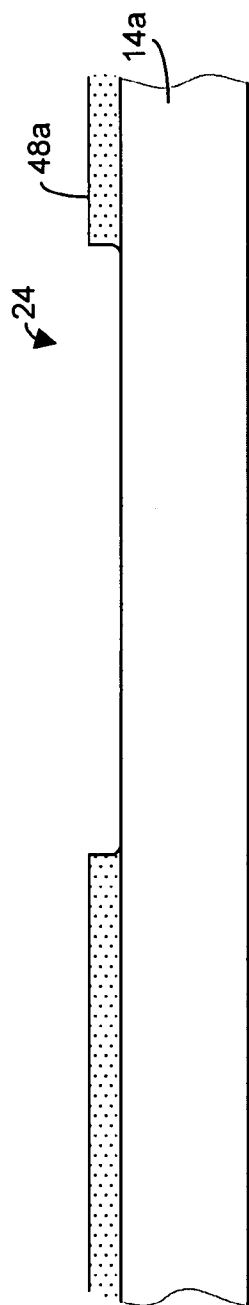

FIGURE 57C

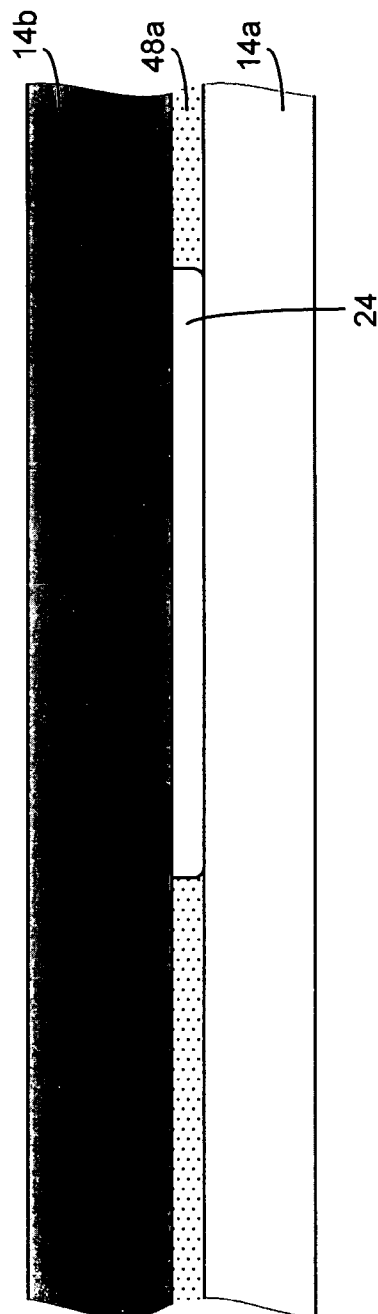

FIGURE 57D

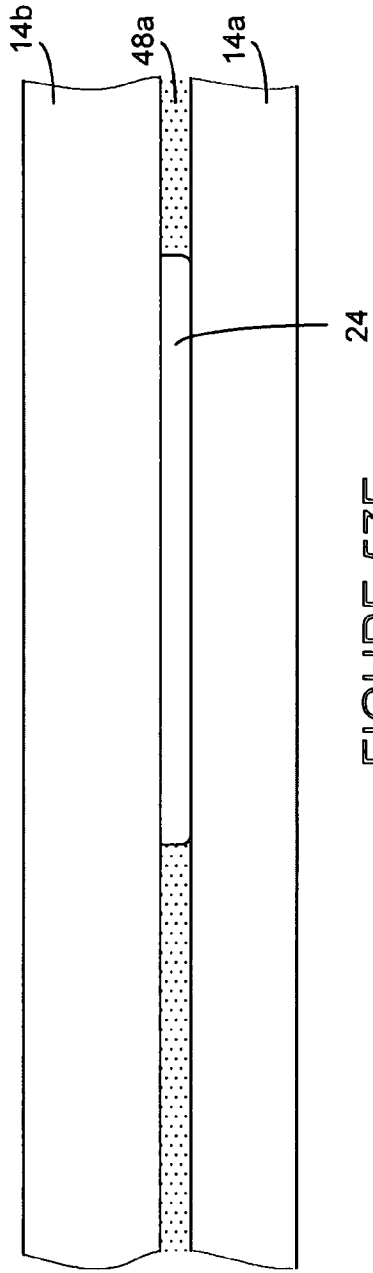

FIGURE 57E

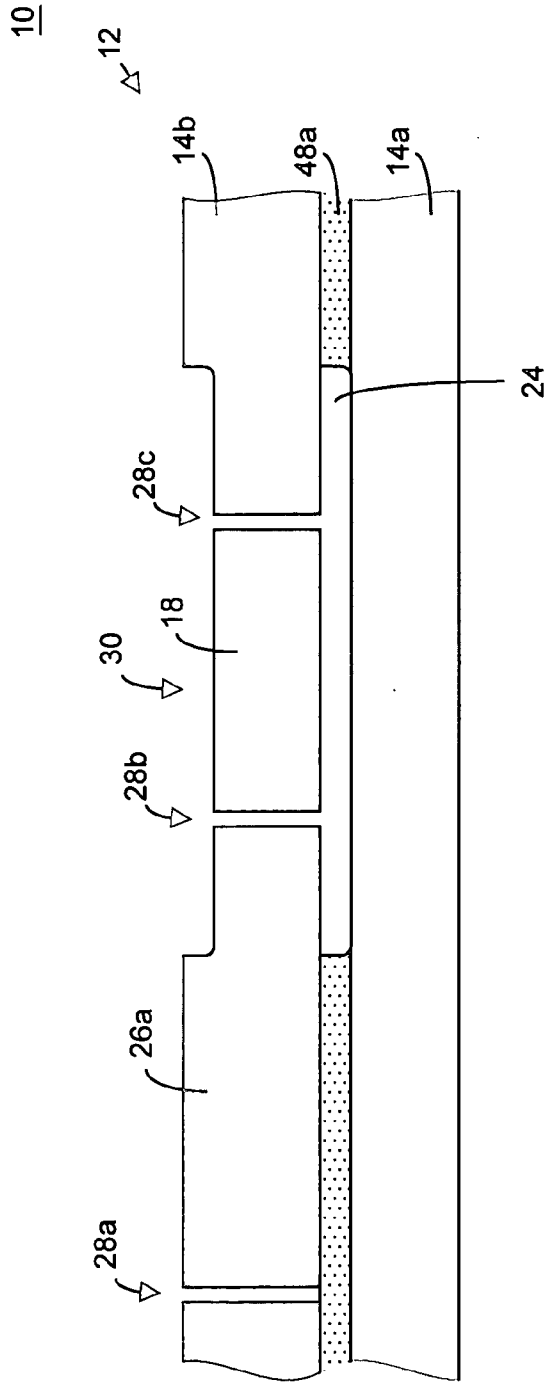

FIGURE 57F

10

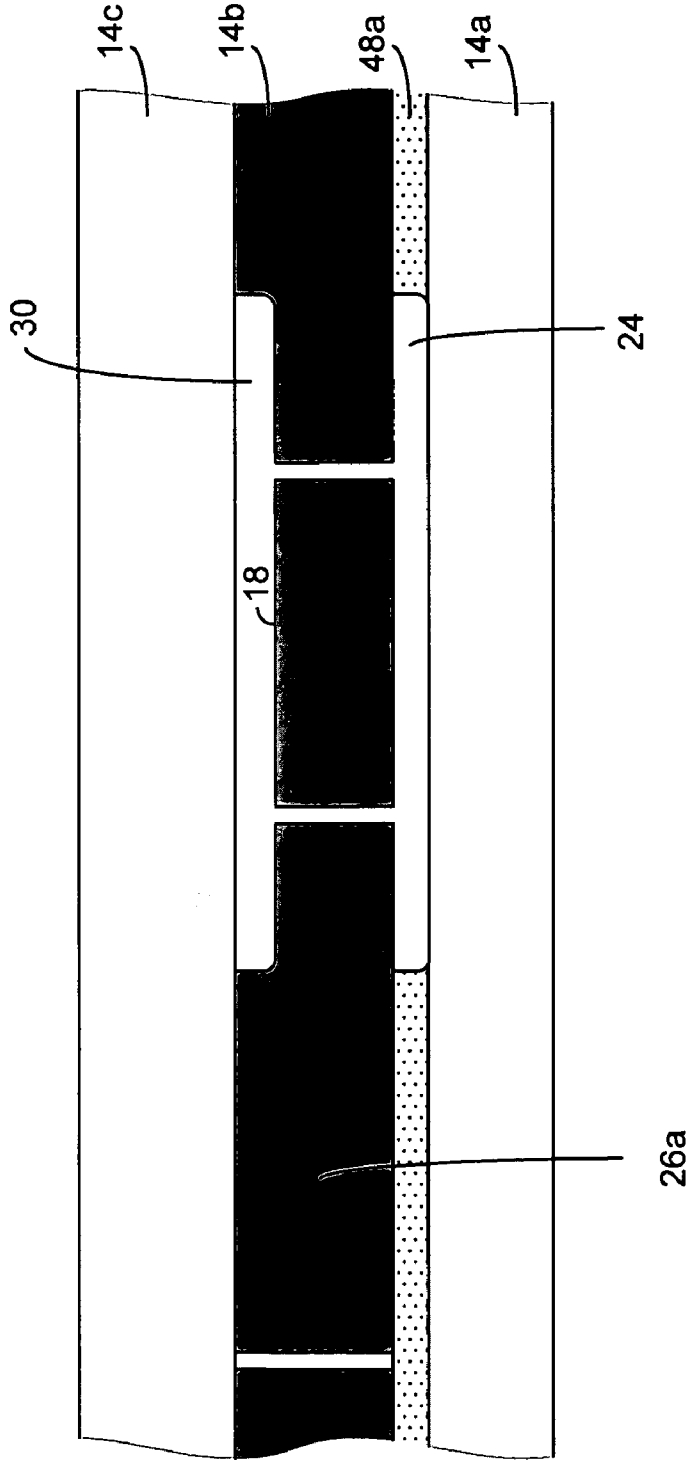

FIGURE 57G

10

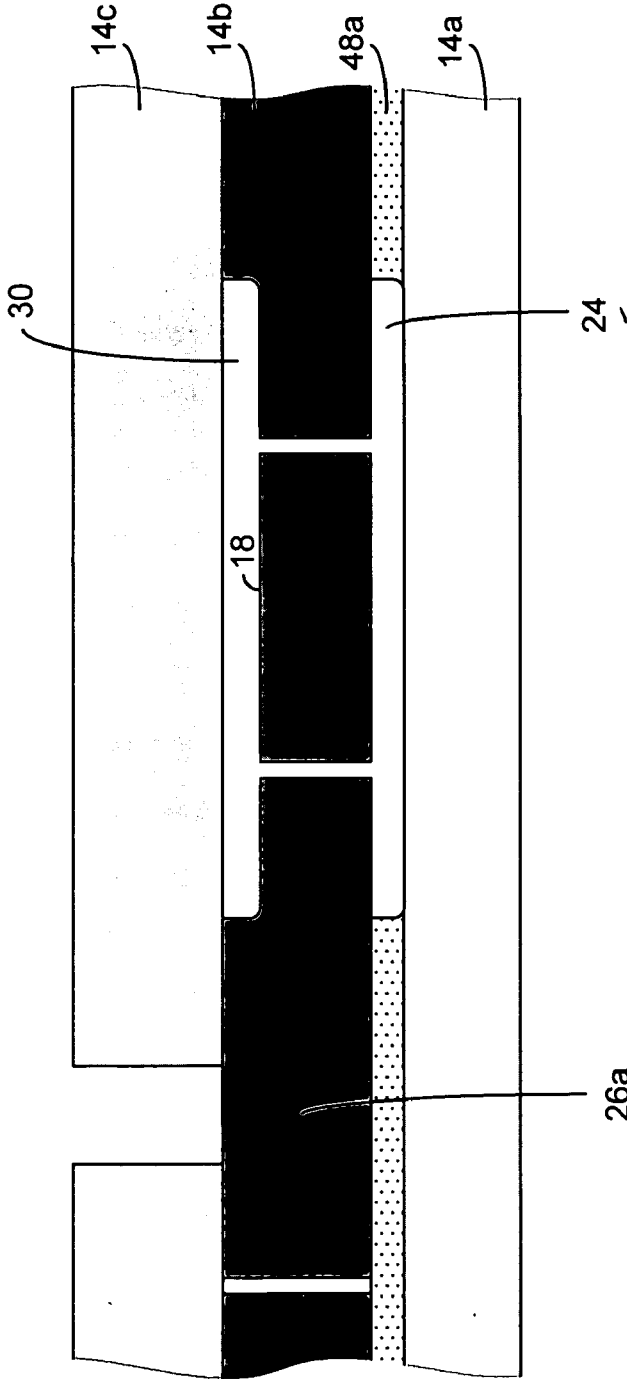

FIGURE 57H

10

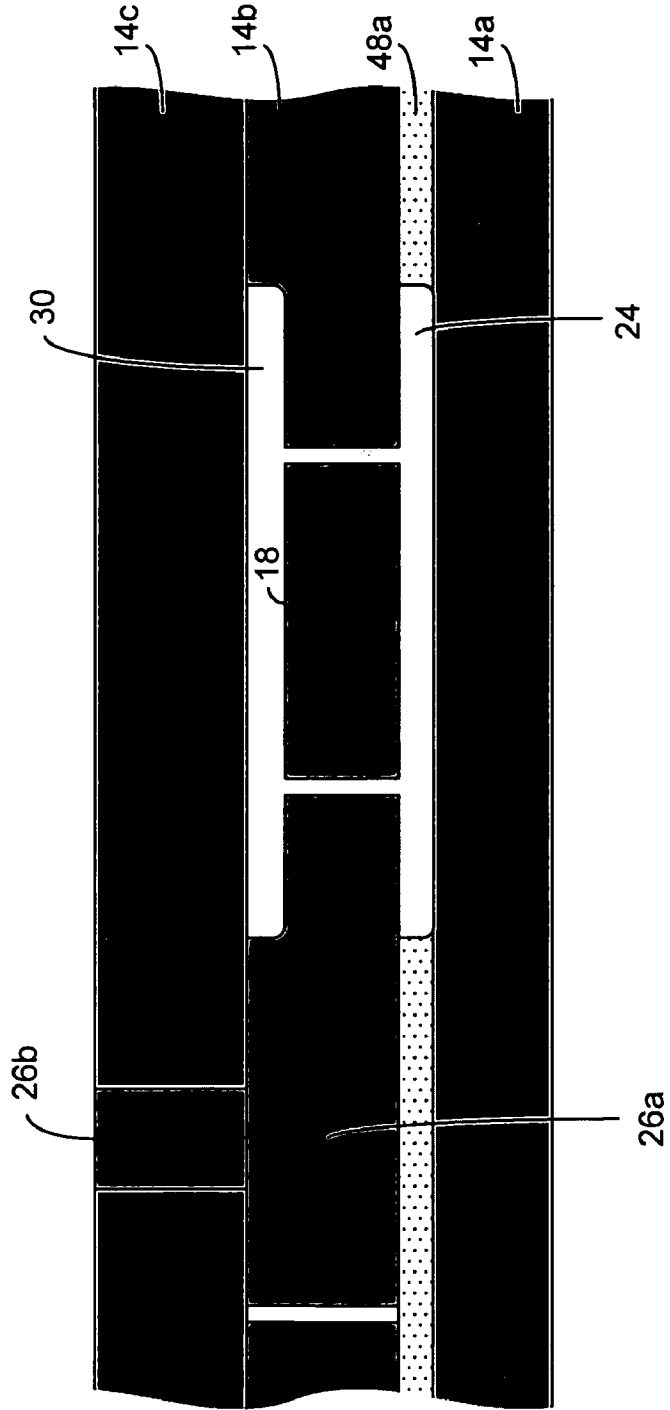

FIGURE 57I

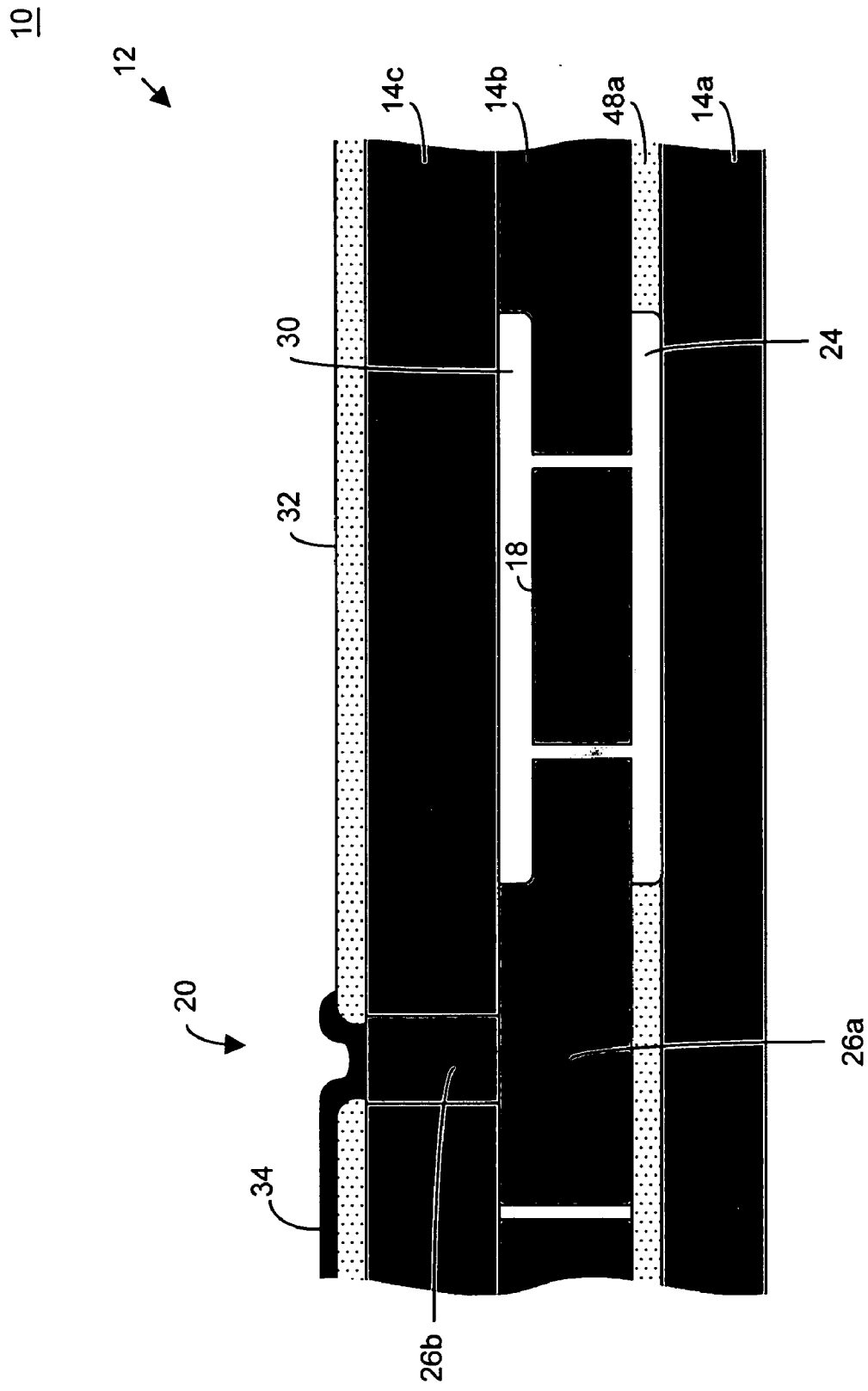

FIGURE 57J

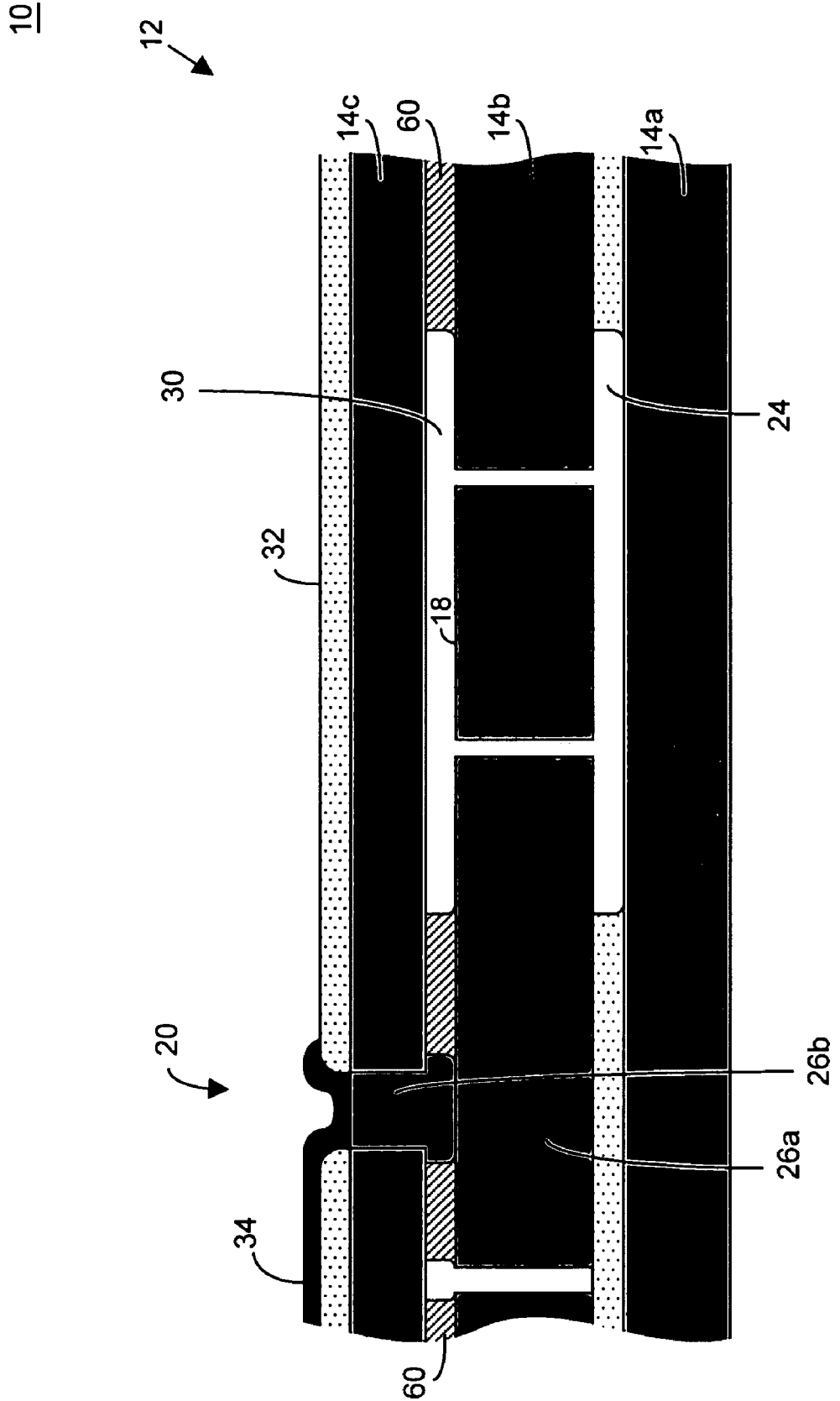

FIGURE 58



FIGURE 59A

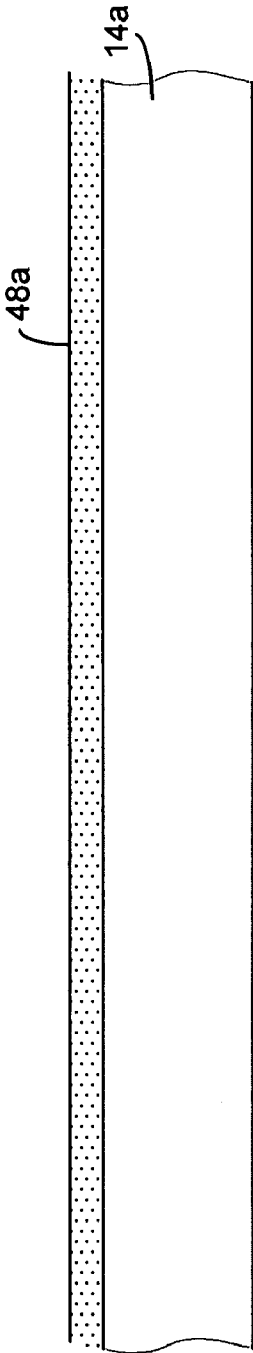

FIGURE 59B

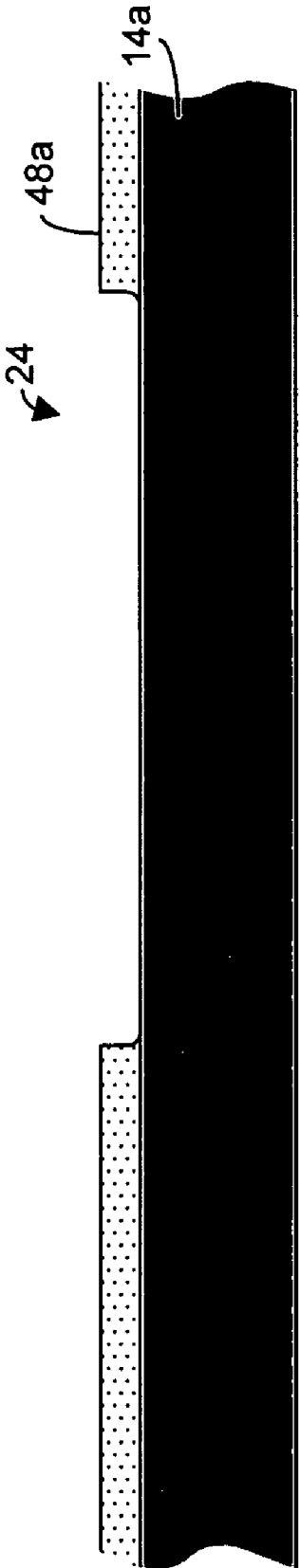

FIGURE 59C

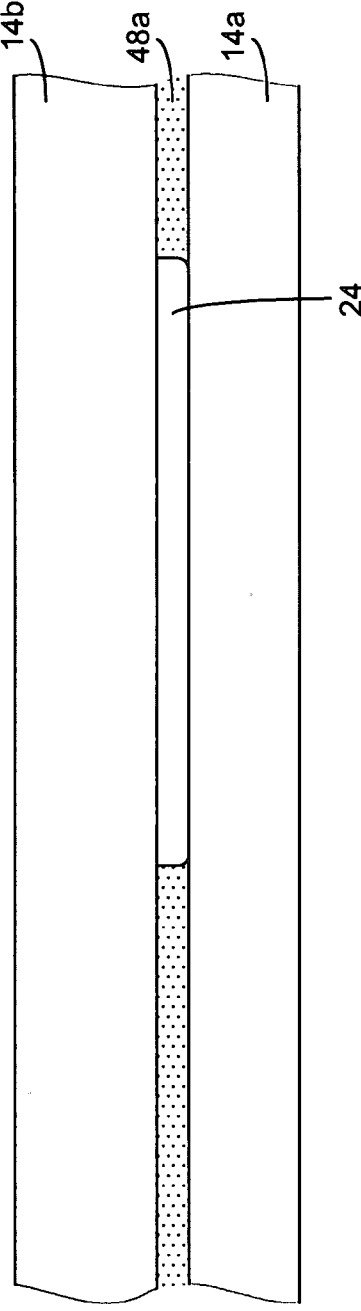

FIGURE 59D

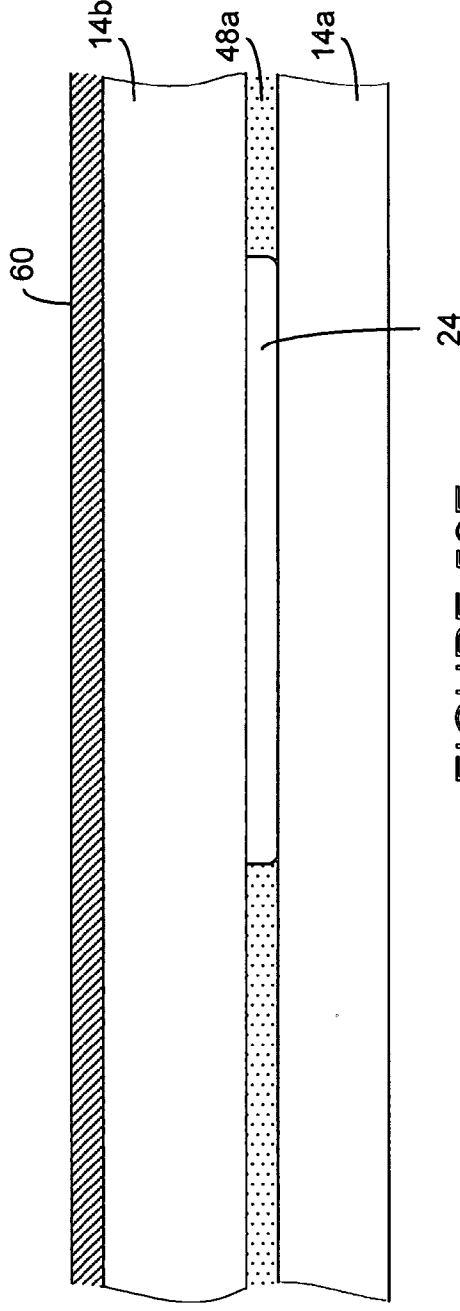

FIGURE 59E

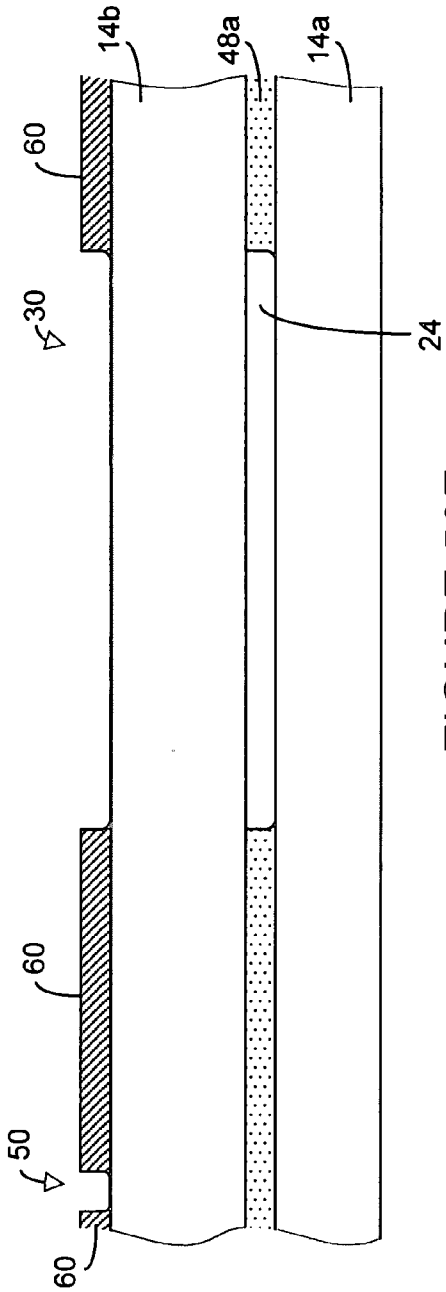

FIGURE 59F

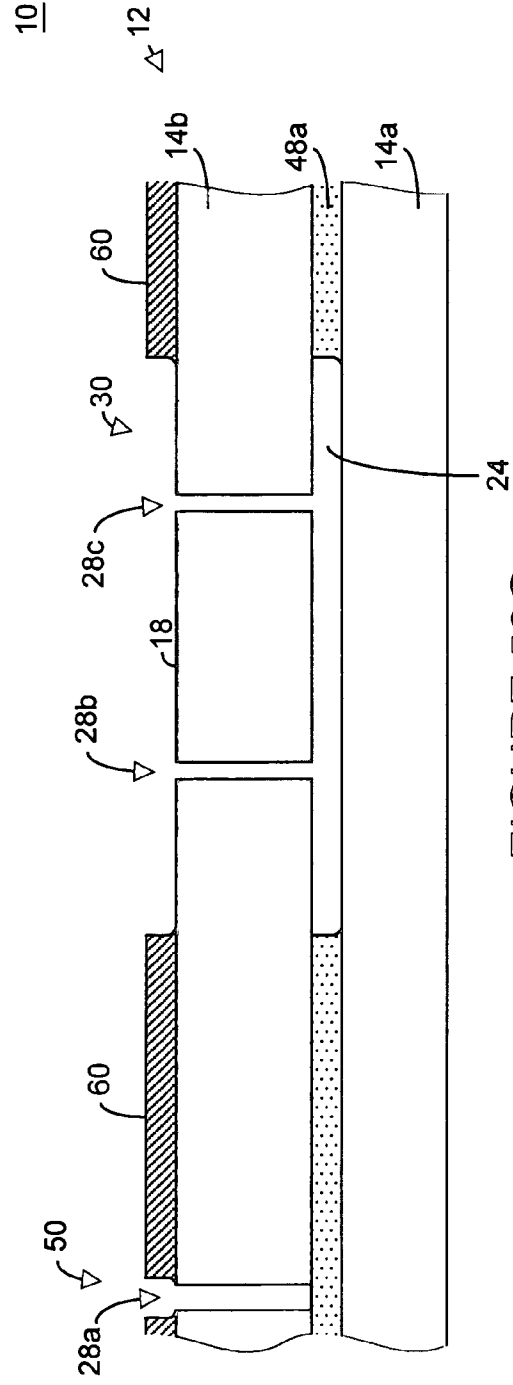

FIGURE 59G

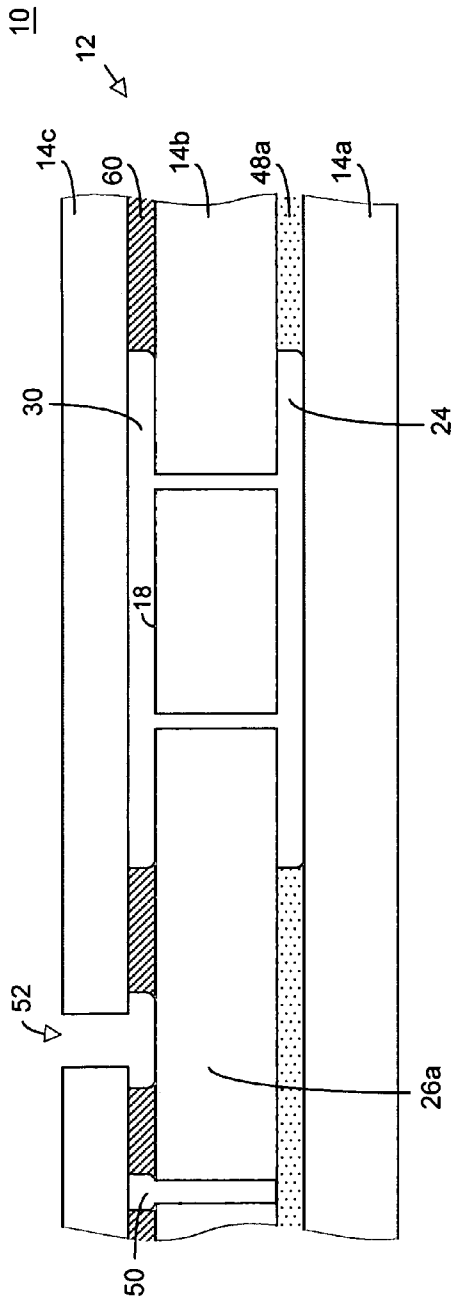

FIGURE 59J

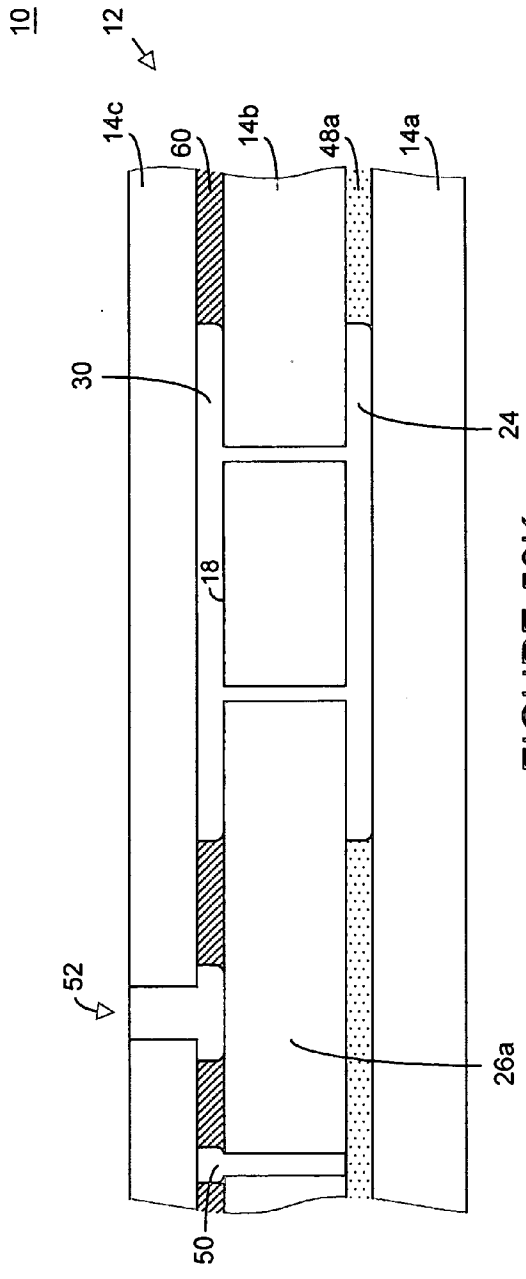

FIGURE 59K

10

12

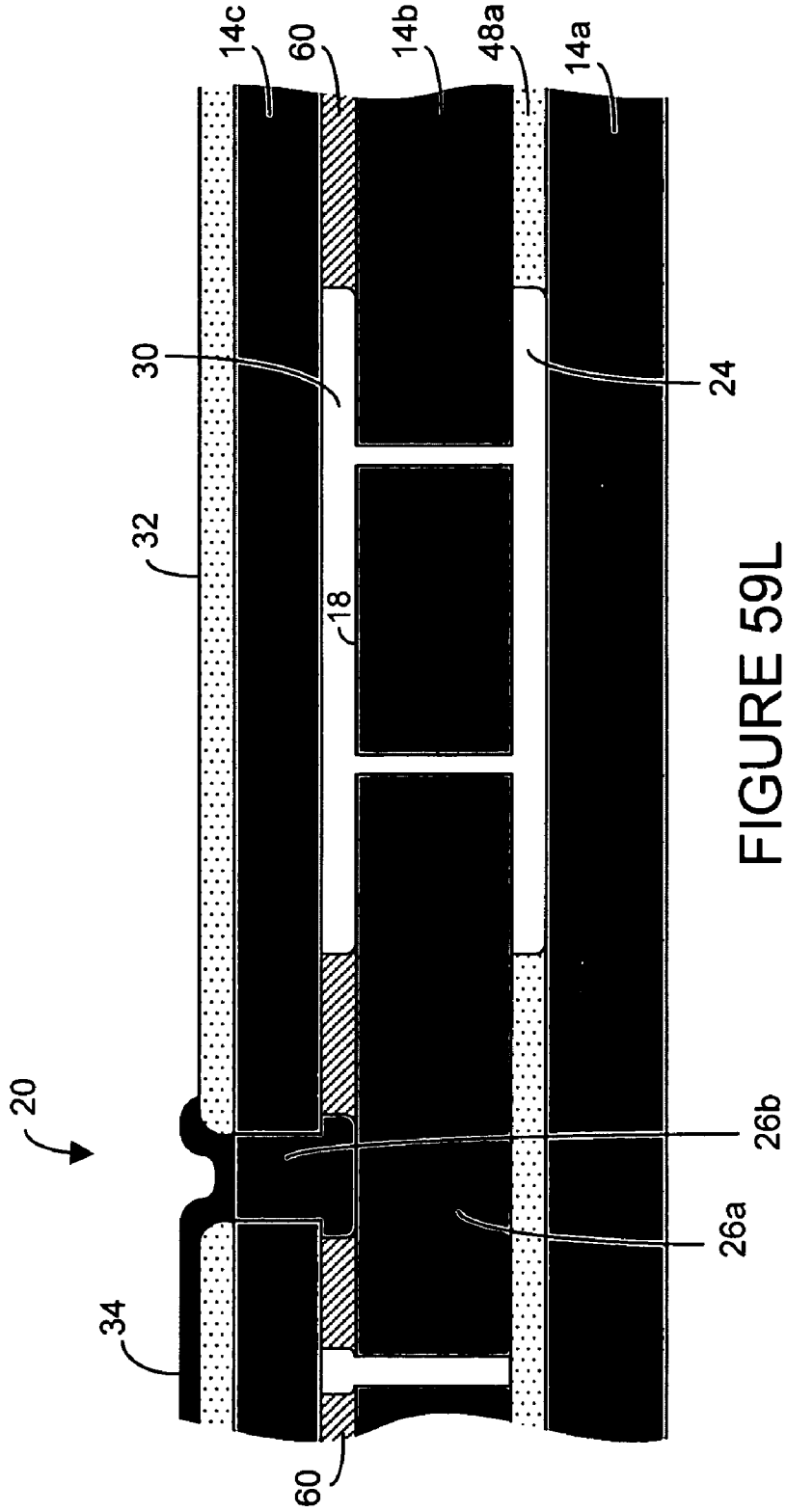

FIGURE 59L

10

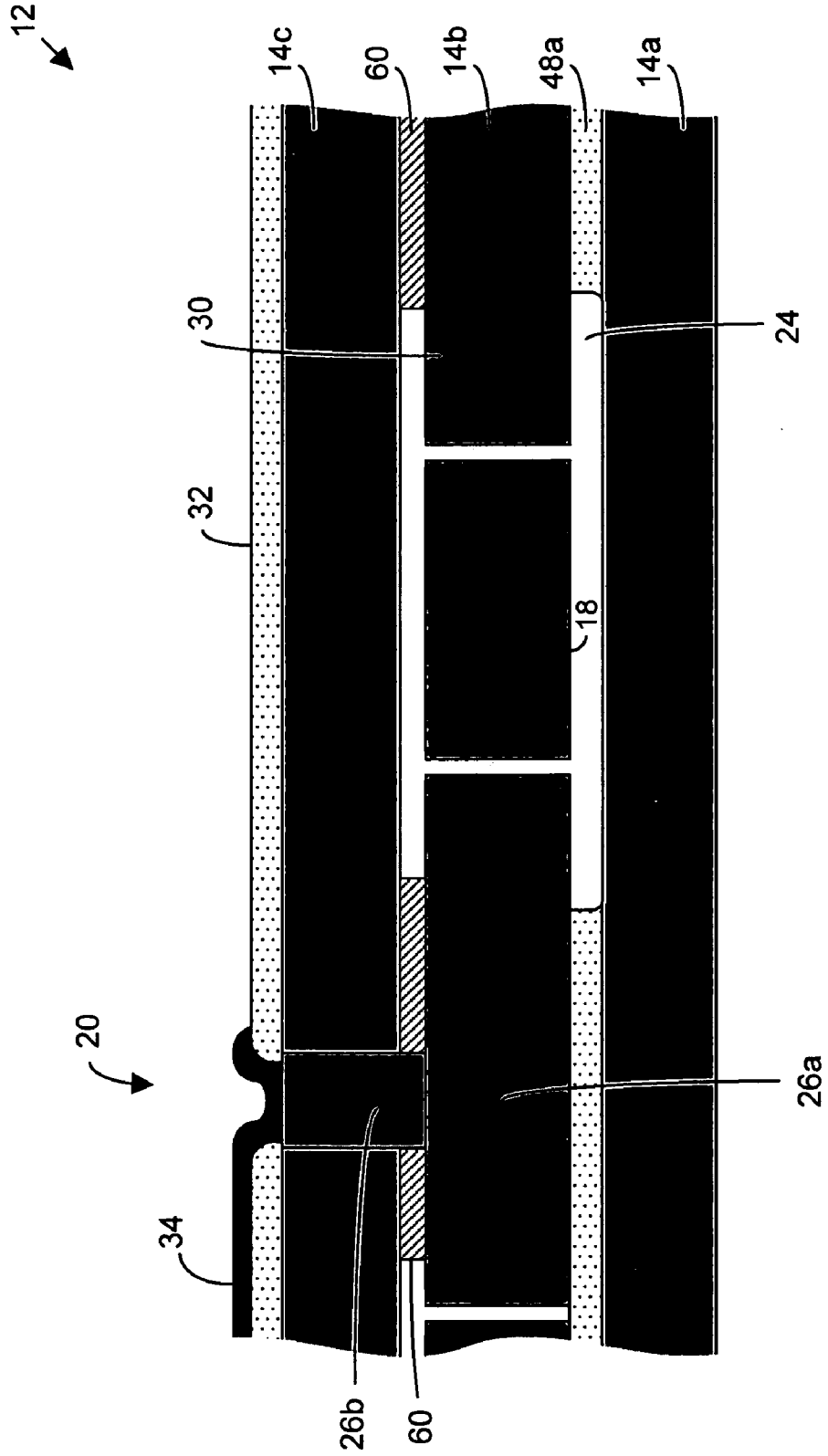

FIGURE 60



FIGURE 61A

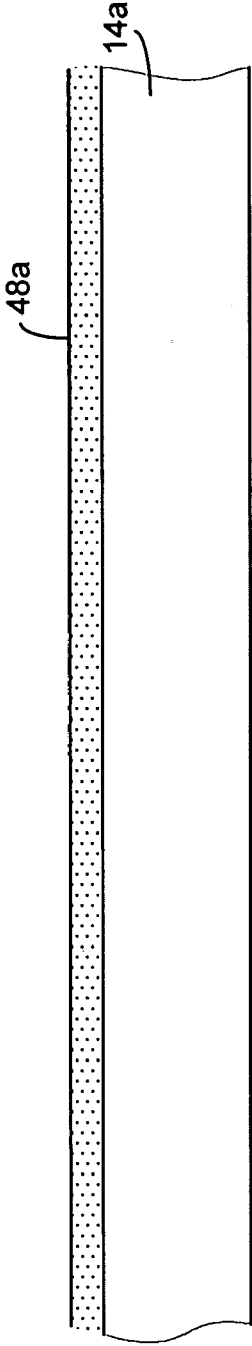

FIGURE 61B

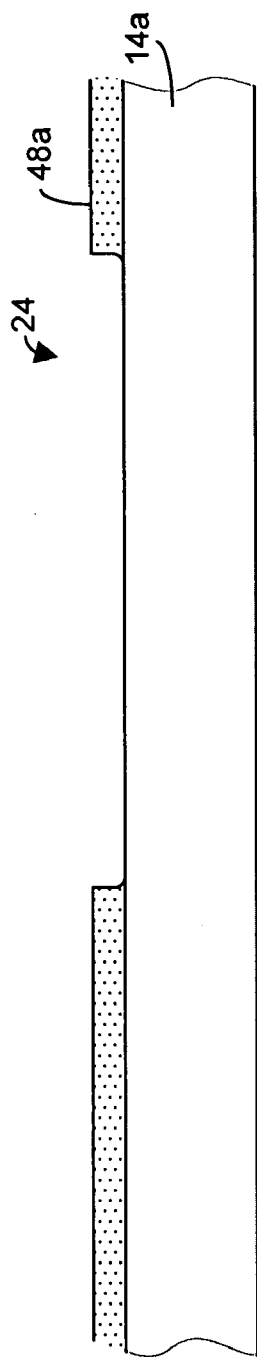

FIGURE 61C

10

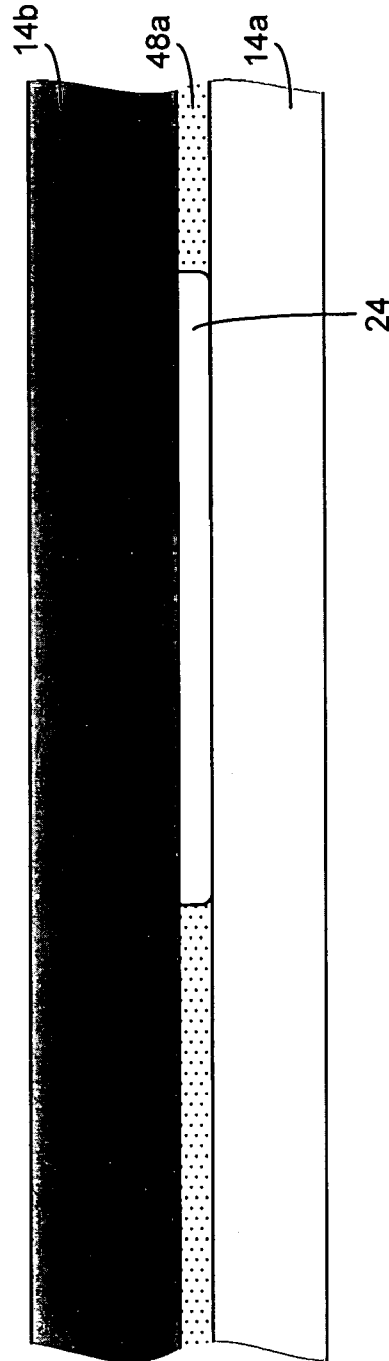

FIGURE 61D

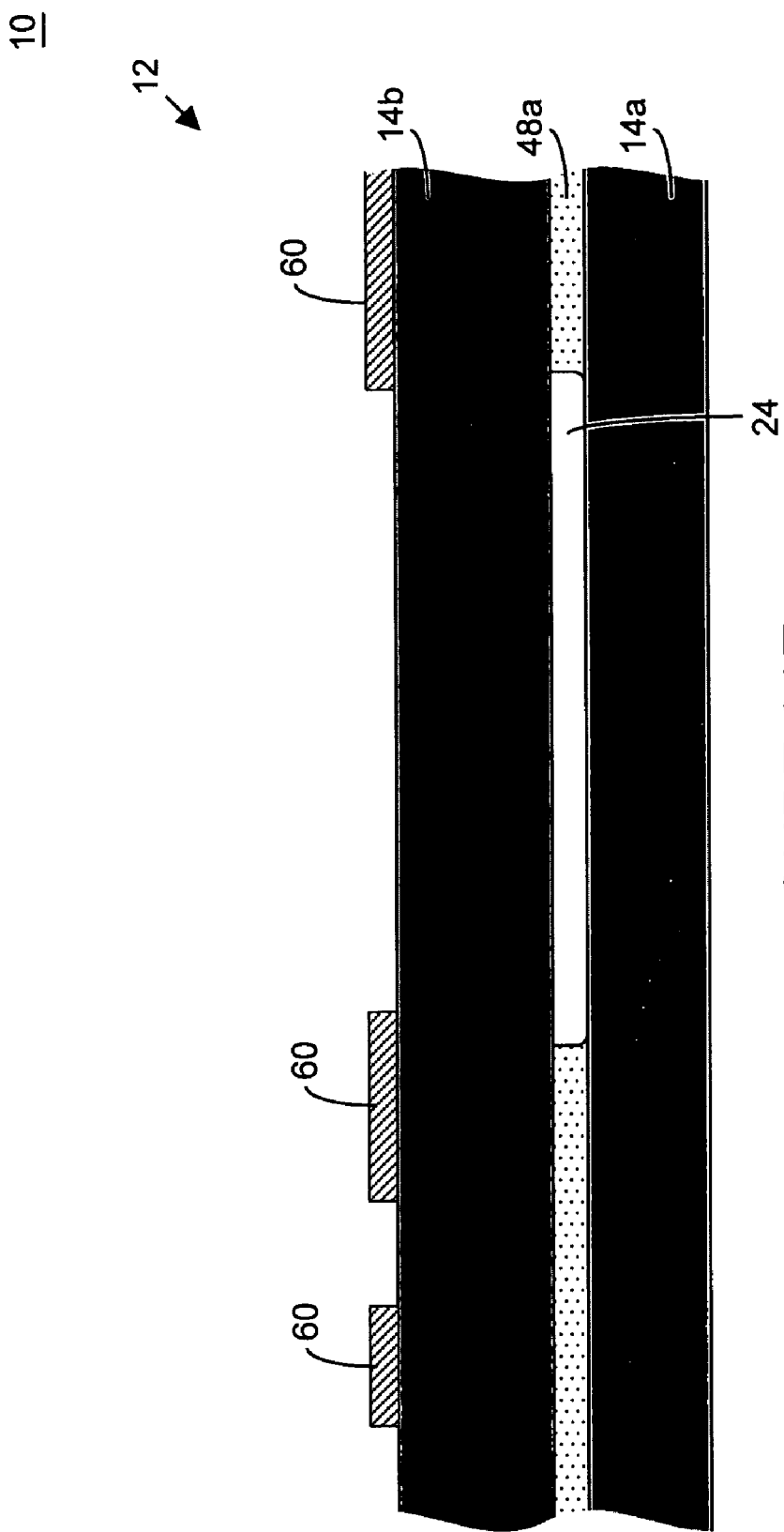

FIGURE 61E

10

12

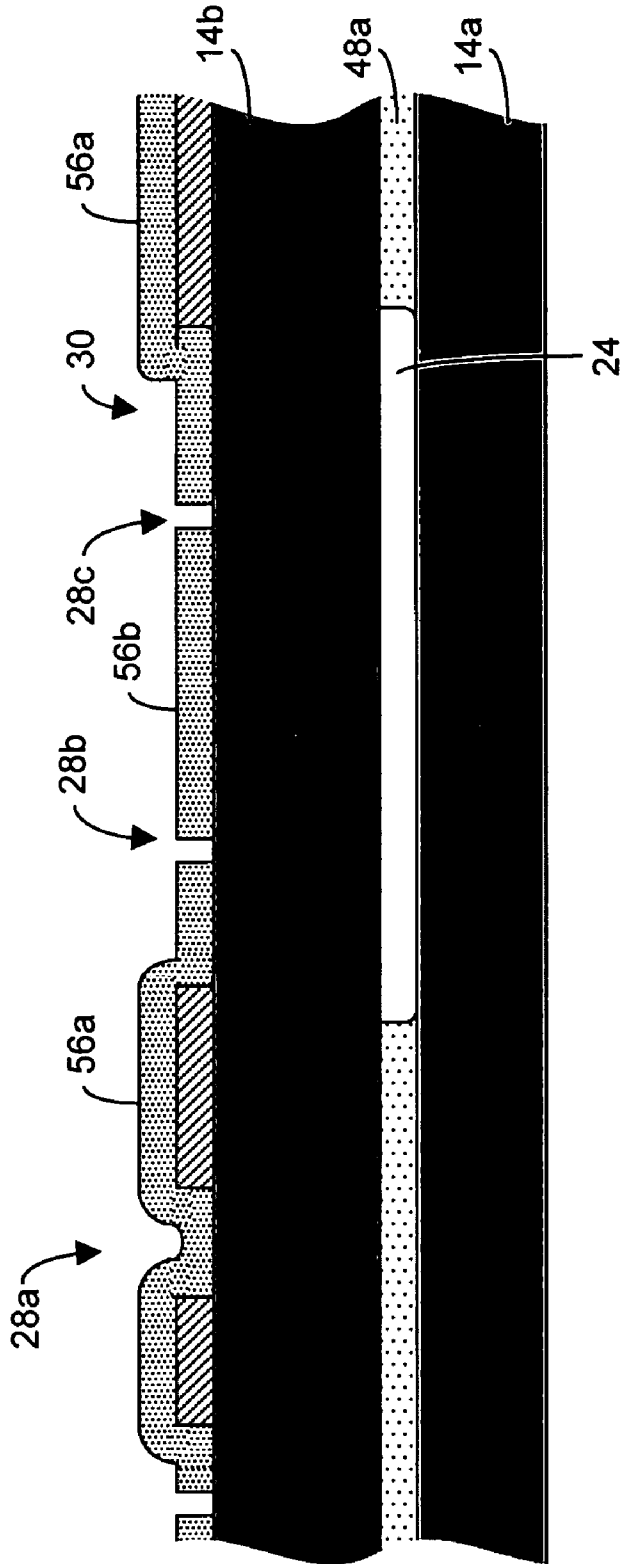

FIGURE 61F

10

12

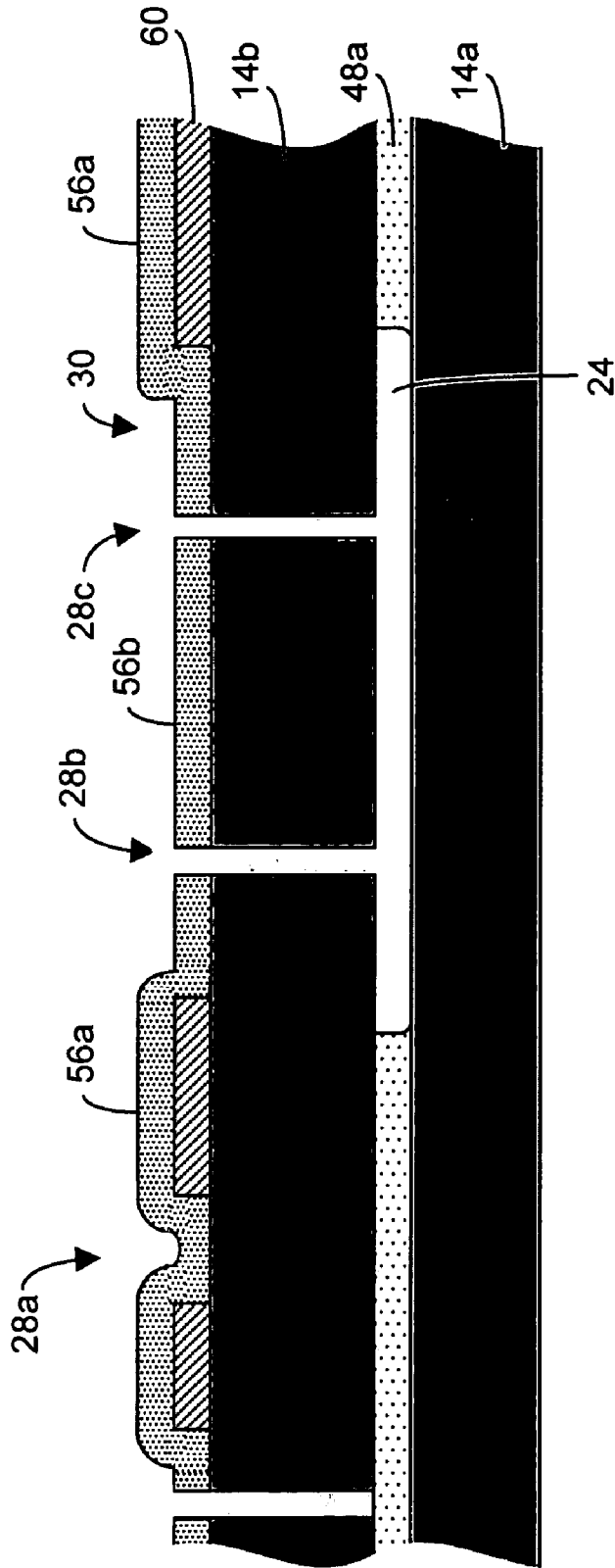

FIGURE 61G

10

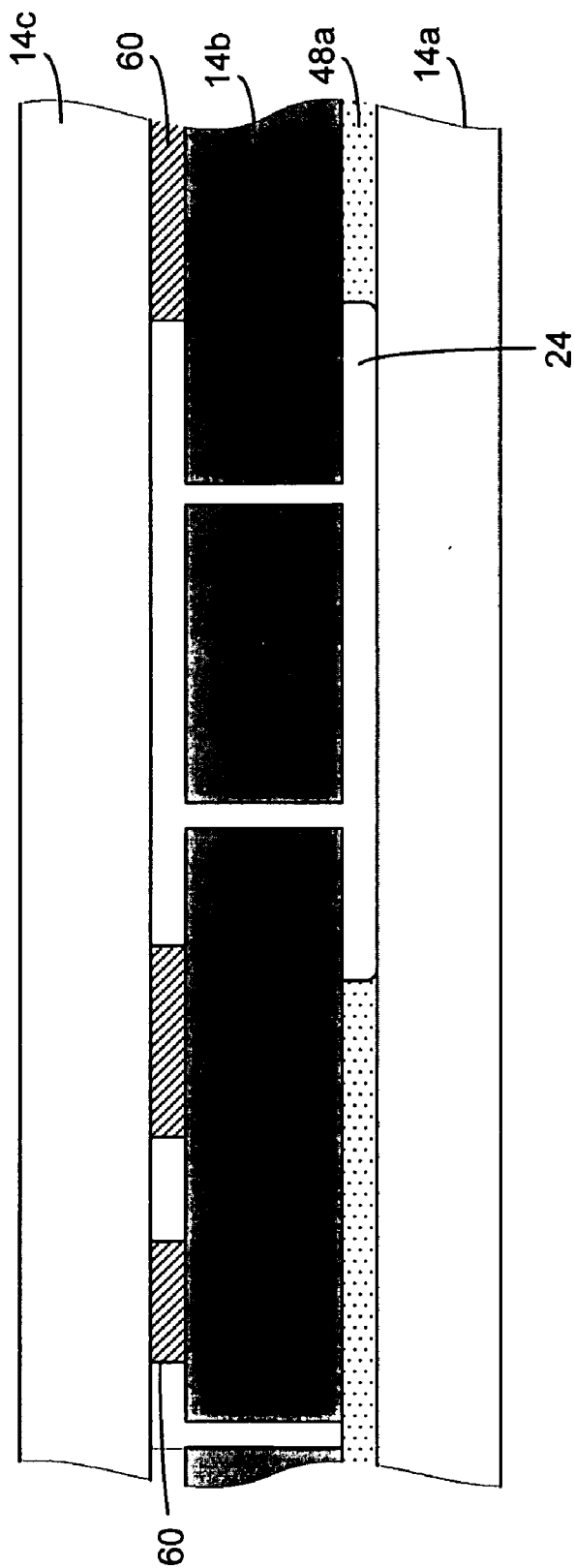

FIGURE 61H

10

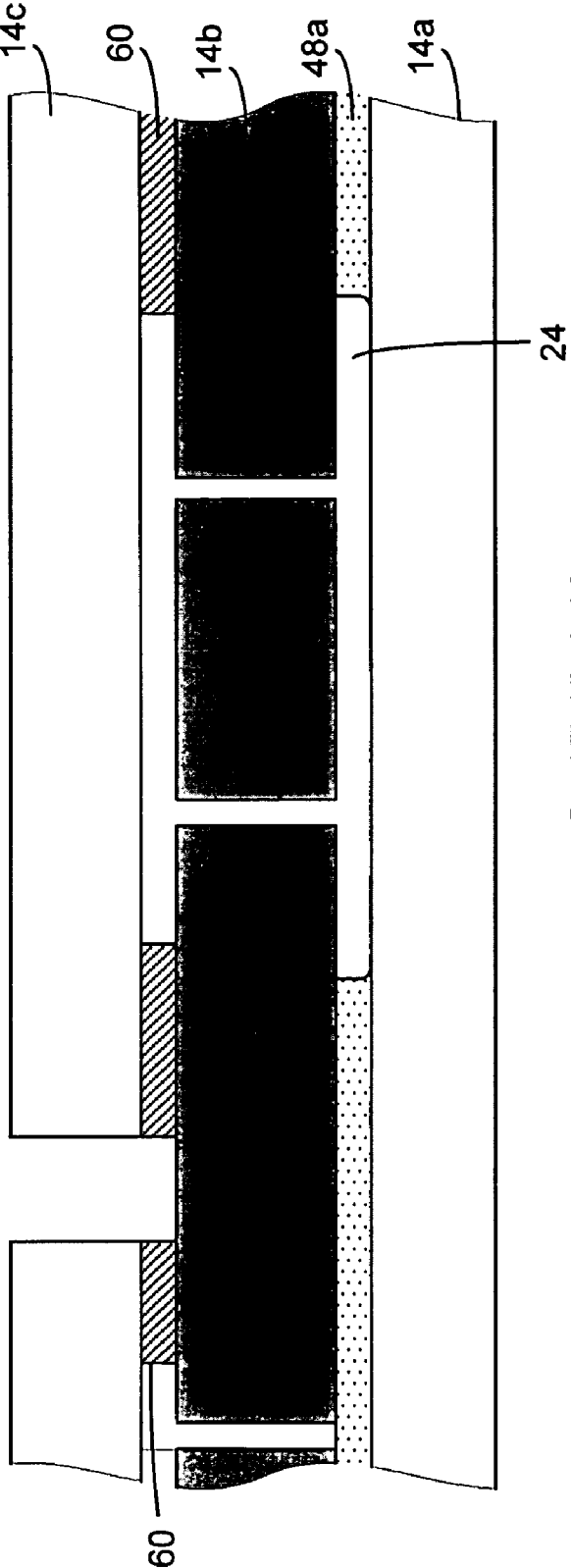

FIGURE 61I

10

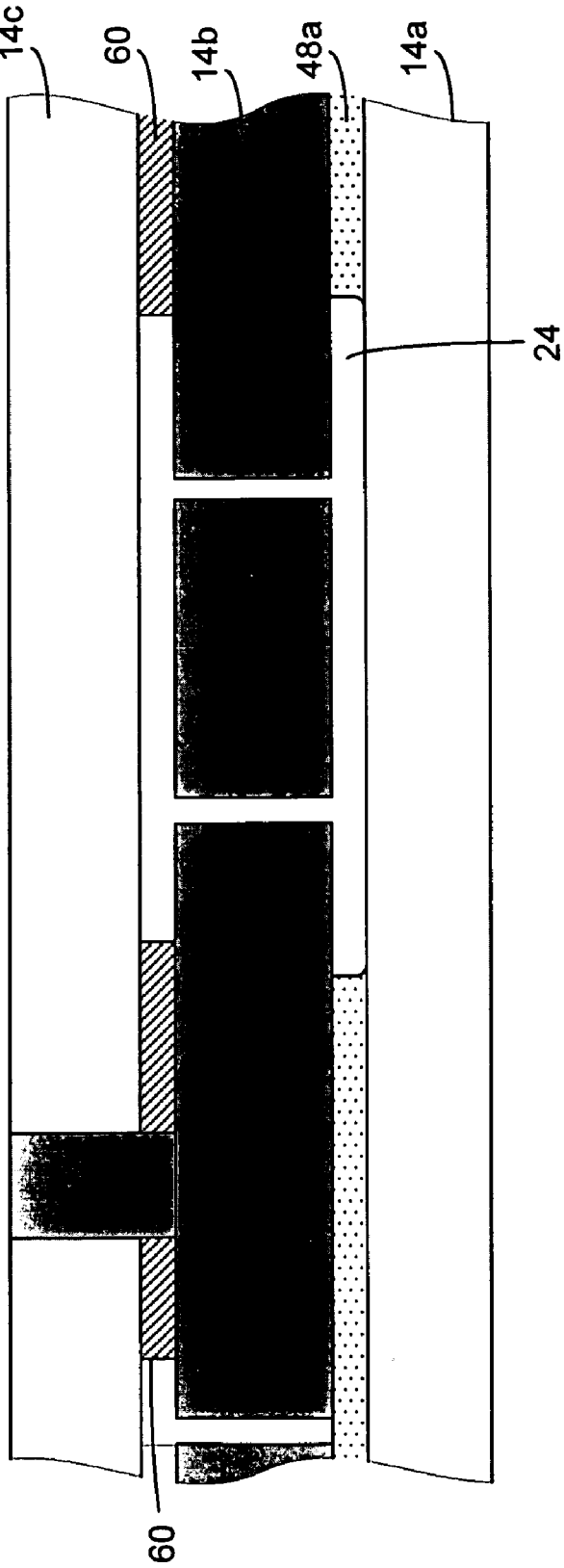

FIGURE 61J

10

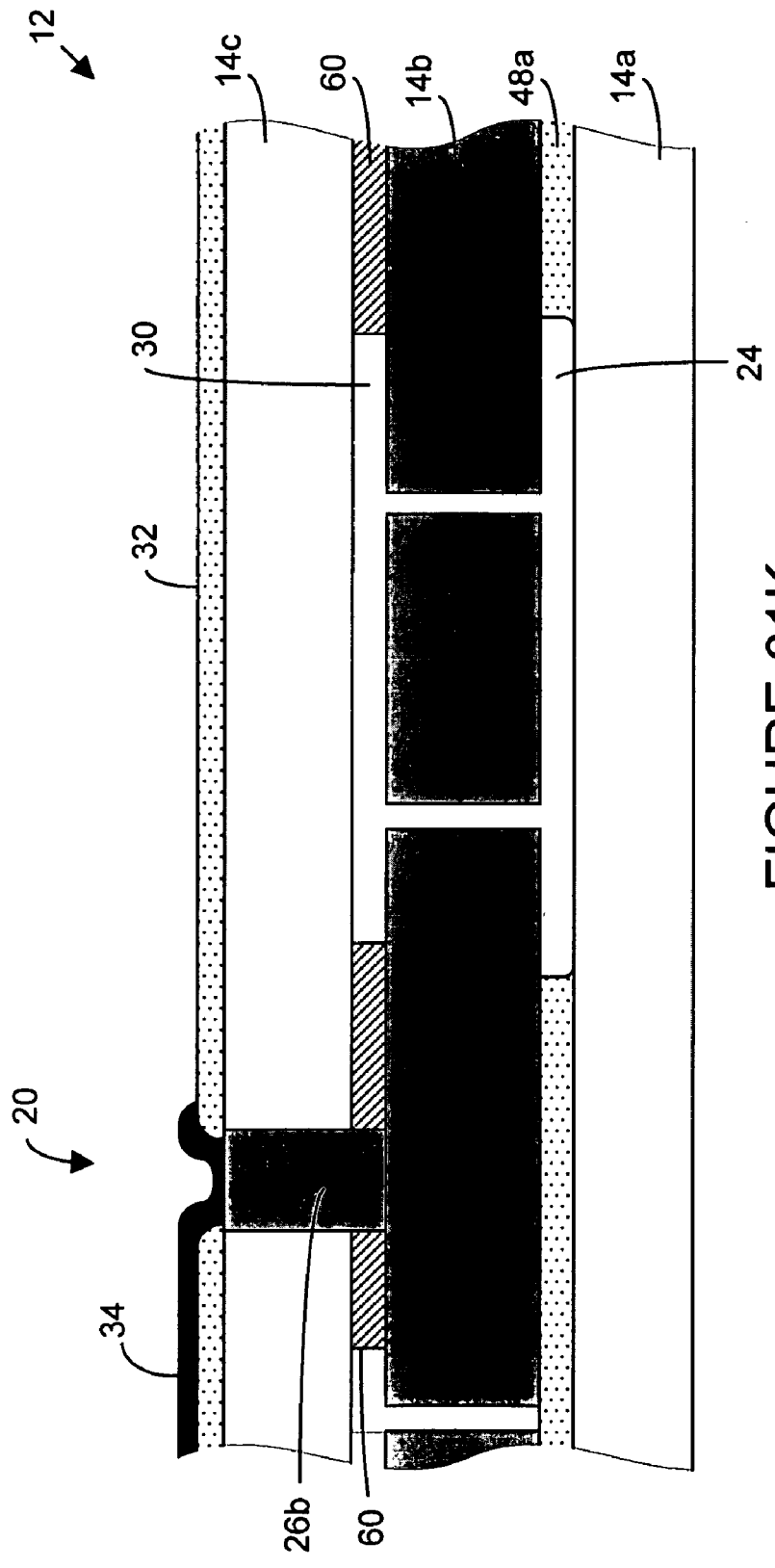

FIGURE 61K

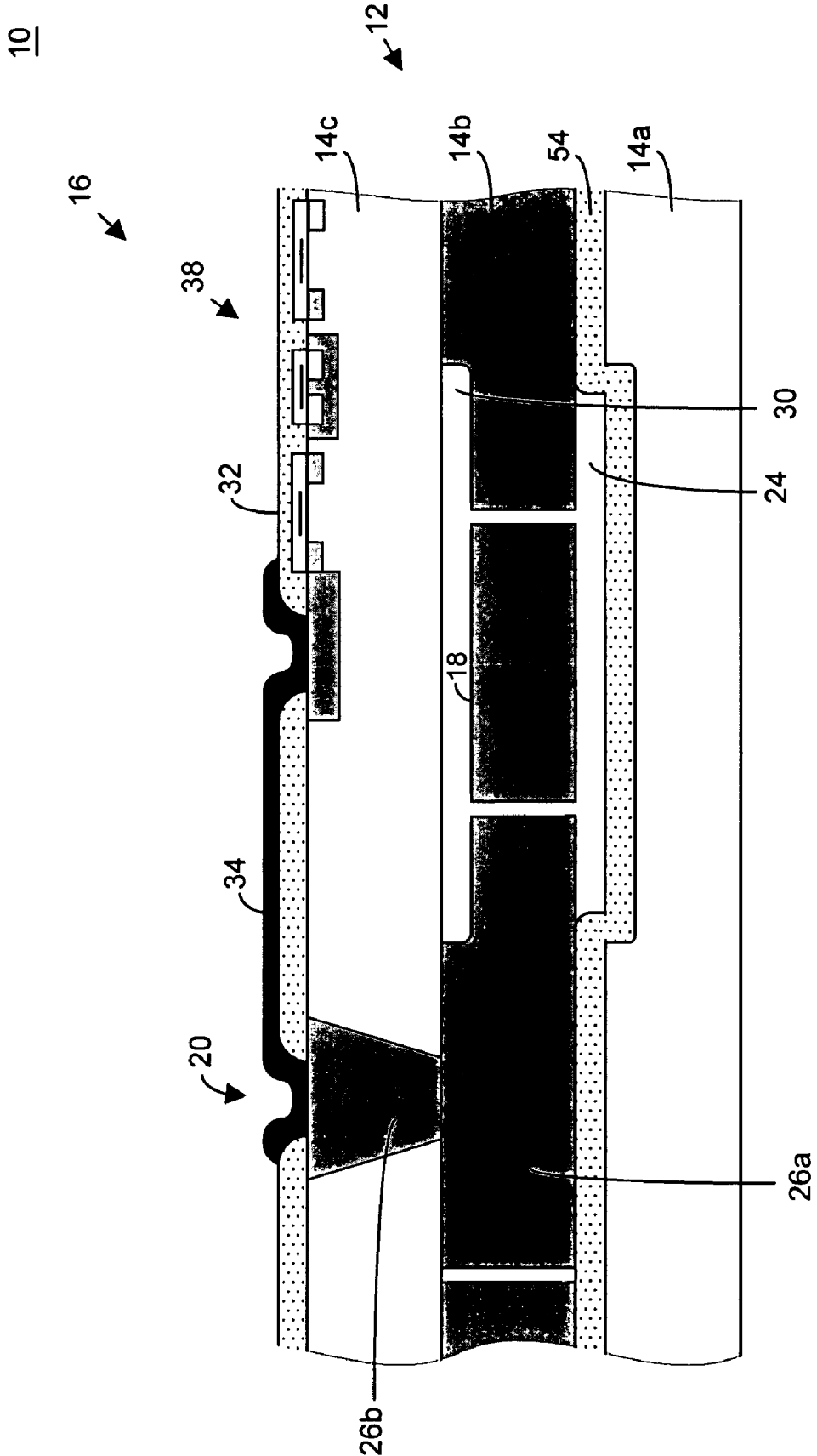

FIGURE 62

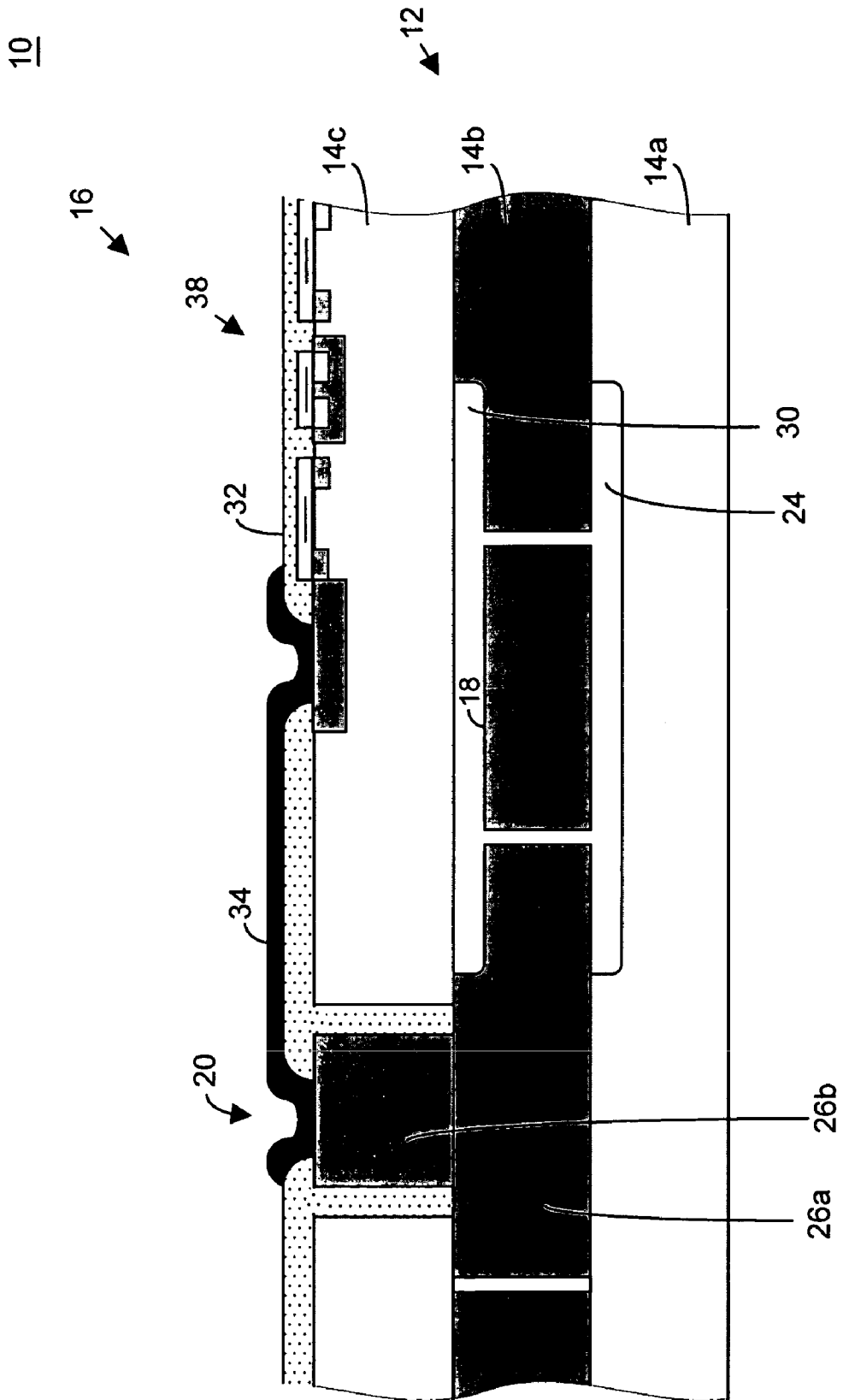

FIGURE 63

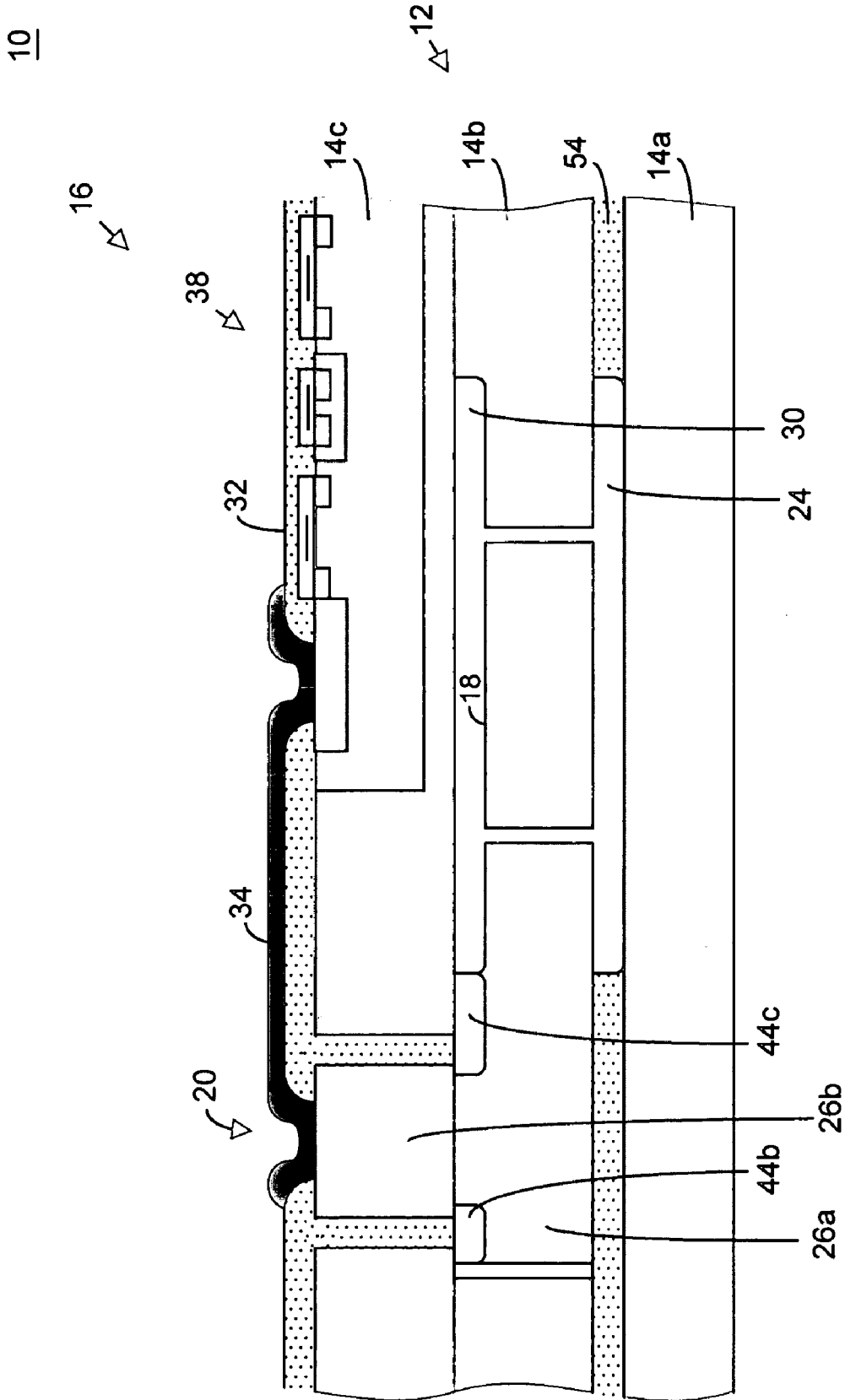

FIGURE 64

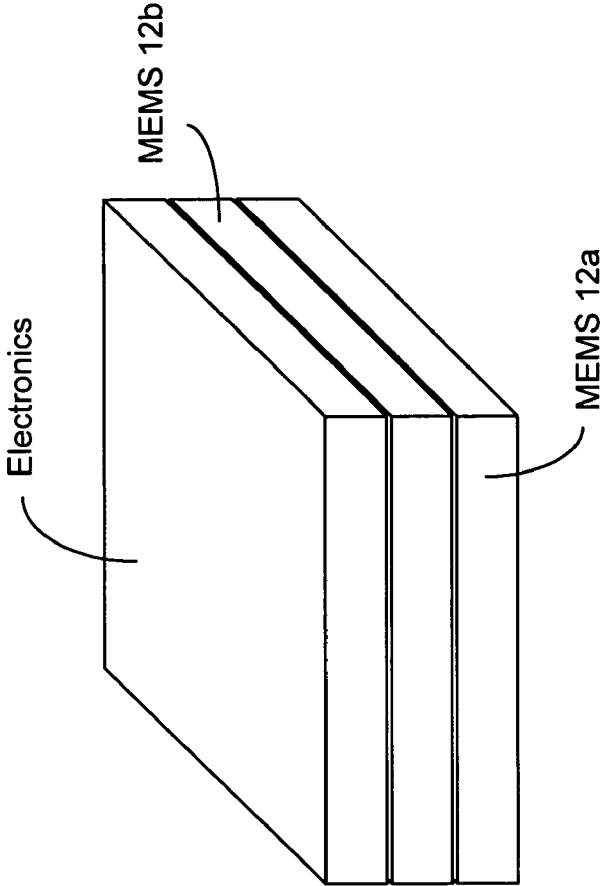

FIGURE 66A

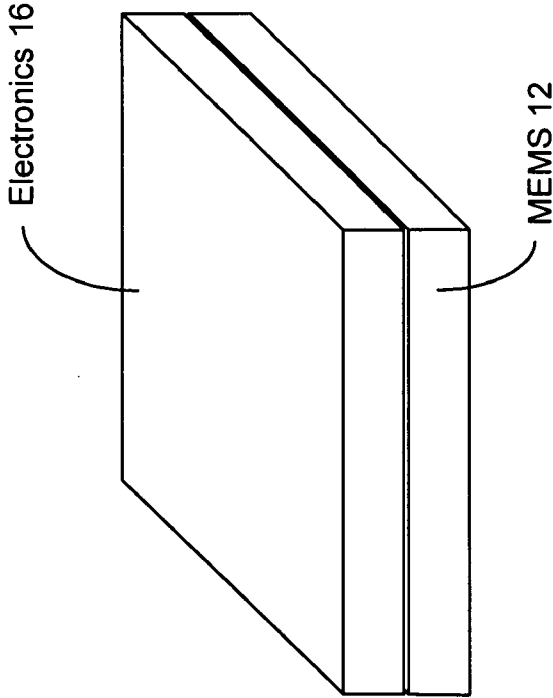

FIGURE 65

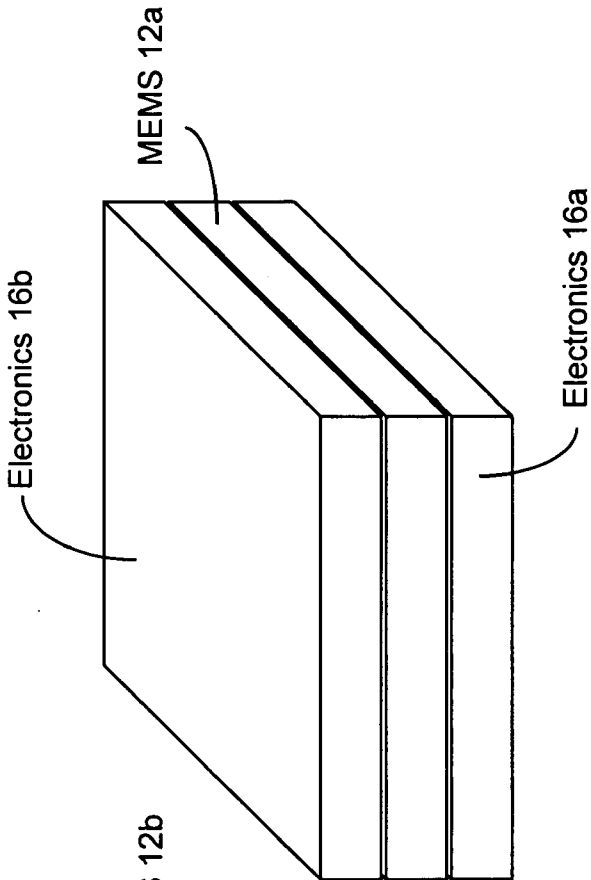

FIGURE 66C

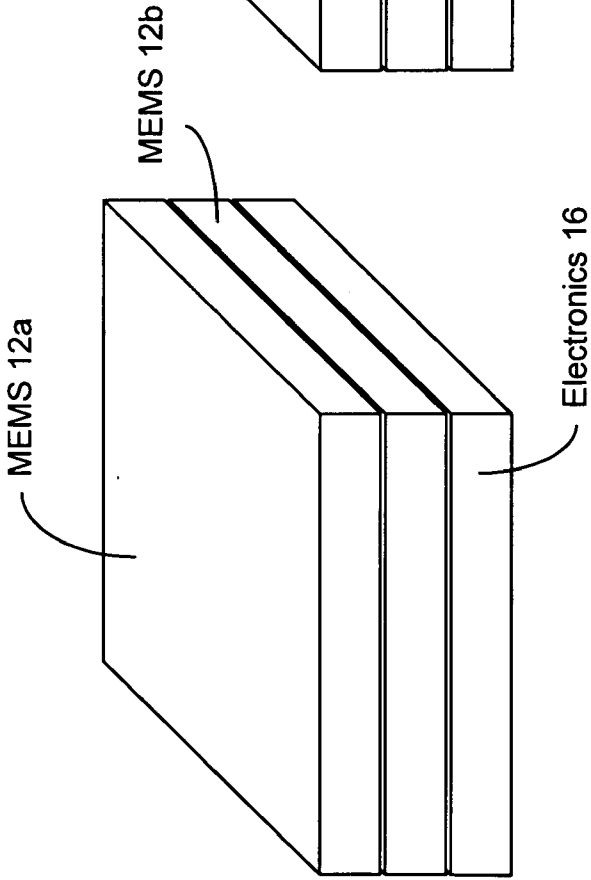

FIGURE 66B

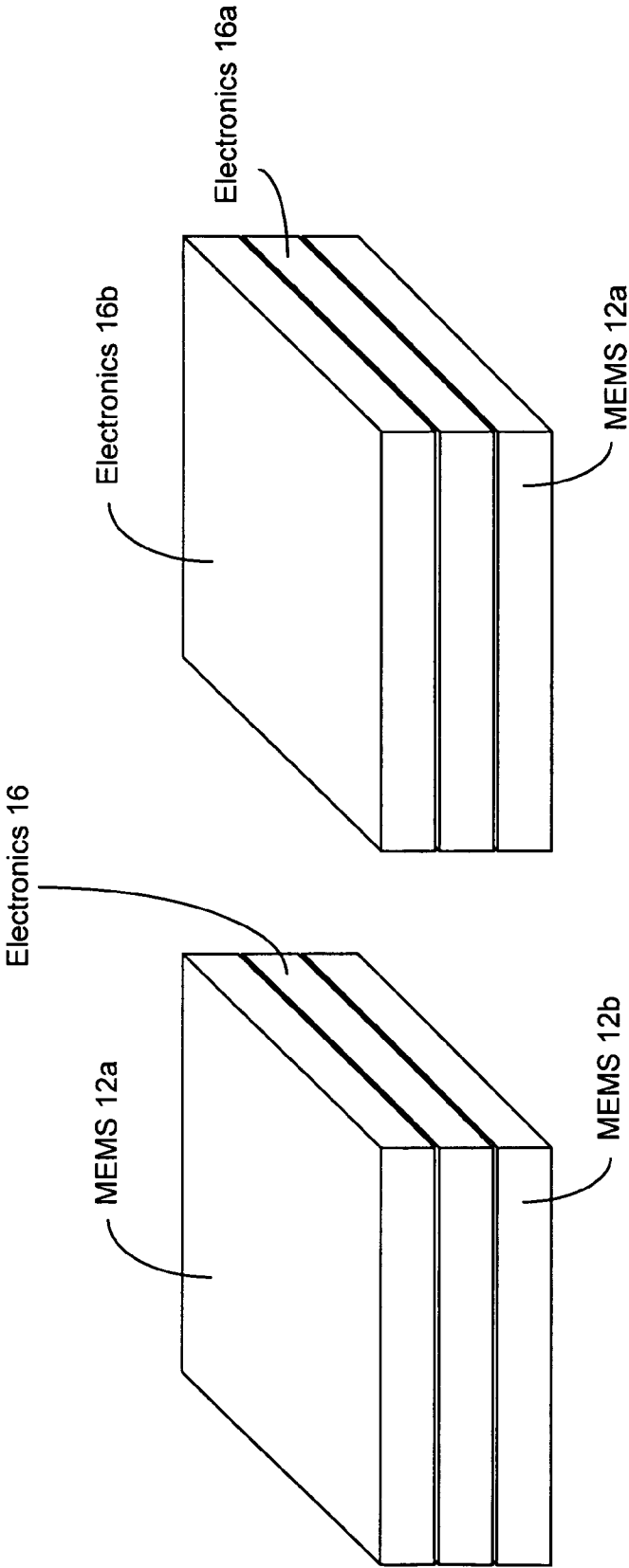

FIGURE 66E

FIGURE 66D

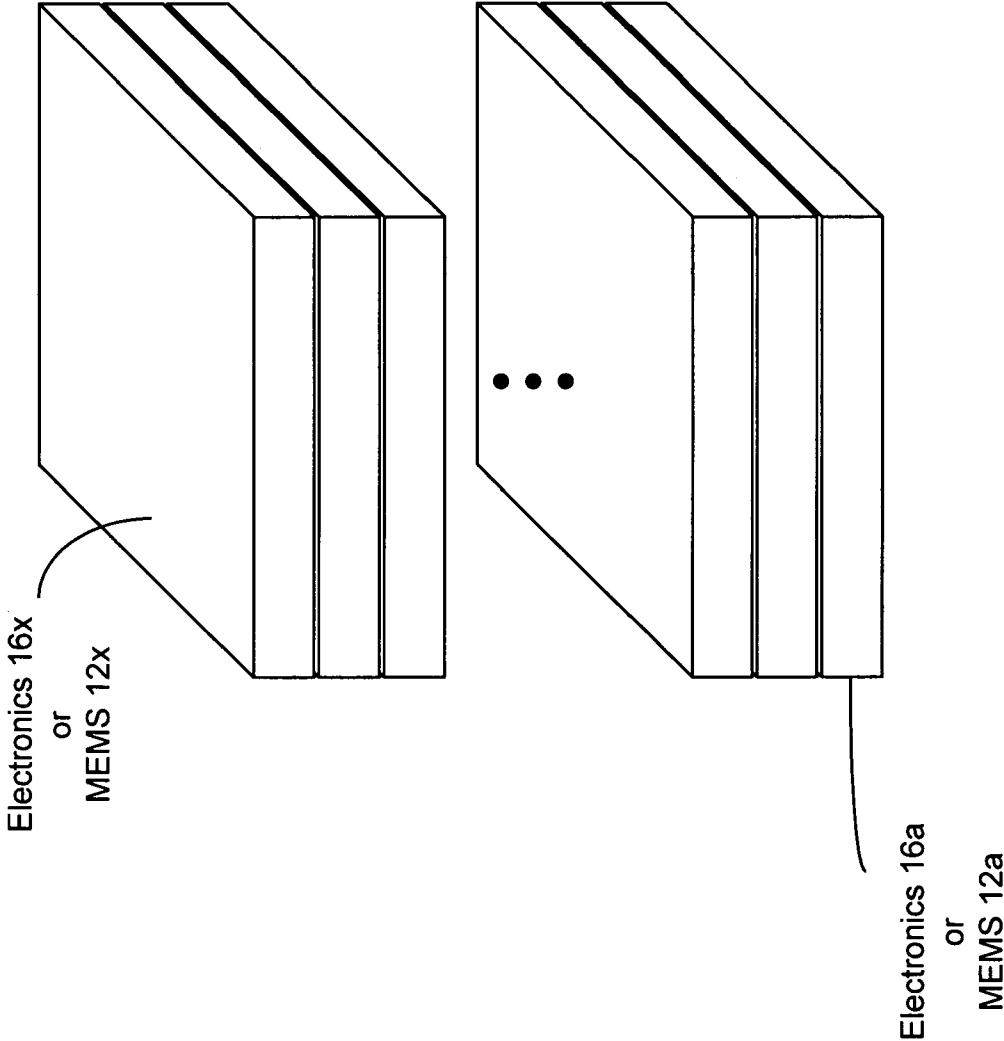

FIGURE 66F

**WAFER ENCAPSULATED
MICROELECTROMECHANICAL
STRUCTURE AND METHOD OF
MANUFACTURING SAME**

BACKGROUND

[0001] There are many inventions described and illustrated herein. The inventions relate to encapsulation electromechanical structures, for example, microelectromechanical and/or nanoelectromechanical structure (collectively hereinafter “microelectromechanical structures”) and devices/systems including same; and more particularly, in one aspect, for fabricating or manufacturing microelectromechanical systems having mechanical structures that are encapsulated using wafer level encapsulation techniques, and devices/systems incorporated same.

[0002] Microelectromechanical systems, for example, gyroscopes, resonators and accelerometers, utilize micromachining techniques (i.e., lithographic and other precision fabrication techniques) to reduce mechanical components to a scale that is generally comparable to microelectronics. Microelectromechanical systems typically include a mechanical structure fabricated from or on, for example, a silicon substrate using micromachining techniques.

[0003] The mechanical structures are typically sealed in a chamber. The delicate mechanical structure may be sealed in, for example, a hermetically sealed metal or ceramic container or bonded to a semiconductor or glass-like substrate having a chamber to house, accommodate or cover the mechanical structure. In the context of the hermetically sealed metal or ceramic container, the substrate on, or in which, the mechanical structure resides may be disposed in and affixed to the metal or ceramic container. The hermetically sealed metal or ceramic container often also serves as a primary package as well.

[0004] In the context of the semiconductor or glass-like substrate packaging technique, the substrate of the mechanical structure may be bonded to another substrate (i.e., a “cover” wafer) whereby the bonded substrates form a chamber within which the mechanical structure resides. In this way, the operating environment of the mechanical structure may be controlled and the structure itself protected from, for example, inadvertent contact.

SUMMARY OF THE INVENTIONS

[0005] There are many inventions described and illustrated herein. The present inventions are neither limited to any single aspect nor embodiment thereof, nor to any combinations and/or permutations of such aspects and/or embodiments. Moreover, each of the aspects of the present inventions, and/or embodiments thereof, may be employed alone or in combination with one or more of the other aspects of the present inventions and/or embodiments thereof. For the sake of brevity, many of those permutations and combinations will not be discussed separately herein.

[0006] In one aspect, the present inventions are directed to a microelectromechanical device comprising a first substrate, a chamber, and a microelectromechanical structure, wherein the microelectromechanical structure is (i) formed from a portion of the first substrate and (ii) at least partially disposed in the chamber. In addition, in this aspect, the microelectromechanical device further includes a second substrate, bonded to the first substrate, wherein a surface of

the second substrate forms a wall of the chamber, as well as a contact. The contact includes (1) a first portion of the contact is (i) formed from a portion of the first substrate and (ii) at least a portion thereof is disposed outside the chamber, and (2) a second portion of the contact is formed from a portion of the second substrate.

[0007] In one embodiment, the second substrate includes polycrystalline silicon, porous polycrystalline silicon, amorphous silicon, silicon carbide, silicon/germanium, germanium, or gallium arsenide. The first substrate may include polycrystalline silicon, porous polycrystalline silicon, amorphous silicon, silicon carbide, silicon/germanium, germanium, or gallium arsenide.

[0008] In addition, in one embodiment, the first portion of the contact is a semiconductor material having a first conductivity, the second substrate is a semiconductor material having a second conductivity, and the second portion of the contact is a semiconductor material having the first conductivity. Notably, the second portion of the contact may be a polycrystalline or monocrystalline silicon that is counterdoped to include the first conductivity.

[0009] The microelectromechanical device may further include a trench, disposed in the second substrate and around at least a portion of the second portion of the contact. The trench may include a first material (for example, an insulation material) disposed therein to electrically isolate the second portion of the contact from the second substrate.

[0010] Notably, the first substrate is a semiconductor on insulator substrate.

[0011] In another principle aspect, the present inventions are directed to a microelectromechanical device comprising a first substrate, a second substrate, wherein the second substrate is bonded to the first substrate, a chamber, and a microelectromechanical structure, wherein the microelectromechanical structure is (i) formed from a portion of the second substrate and (ii) at least partially disposed in the chamber. The microelectromechanical device may further include a third substrate, bonded to the second substrate, wherein a surface of the third substrate forms a wall of the chamber. The microelectromechanical device may also include a contact having (1) a first portion of the contact is (i) formed from a portion of the second substrate and (ii) at least a portion thereof is disposed outside the chamber, and (2) a second portion of the contact is formed from a portion of the third substrate.

[0012] The second substrate may include polycrystalline silicon, porous polycrystalline silicon, amorphous silicon, silicon carbide, silicon/germanium, germanium, or gallium arsenide. The third substrate may include polycrystalline silicon, porous polycrystalline silicon, amorphous silicon, silicon carbide, silicon/germanium, germanium, or gallium arsenide.

[0013] In one embodiment, the first portion of the contact is a semiconductor material having a first conductivity, the third substrate is a semiconductor material having a second conductivity, and the second portion of the contact is a semiconductor material having the first conductivity. Notably, in one embodiment, the second portion of the contact may be a polycrystalline or monocrystalline silicon that is counterdoped to include the first conductivity.

[0014] The microelectromechanical device may further include a trench, disposed in the third substrate and around at least a portion of the second portion of the contact. The trench may include a first material (for example, an insula-

tion material) disposed therein to electrically isolate the second portion of the contact from the third substrate.

[0015] The microelectromechanical device may also include an isolation region disposed in the second substrate such that the trench is aligned with and juxtaposed to the isolation region. In this embodiment, the first portion of the contact may be a semiconductor material having a first conductivity, the isolation region may be a semiconductor material having a second conductivity, and the second portion of the contact may be a semiconductor material having the first conductivity. A trench may be included to electrically isolate the second portion of the contact from the second substrate. The trench may include a semiconductor material, disposed therein, having the second conductivity.

[0016] In another embodiment, the microelectromechanical device may include an isolation region disposed in the first substrate such that the first portion of the contact is aligned with and juxtaposed to the isolation region.

[0017] In yet another embodiment, the microelectromechanical device may include a first isolation region and a second isolation region. The first isolation region may be disposed in the first substrate such that the first portion of the contact is aligned with and juxtaposed to the first isolation region. The second isolation region may be disposed in the second substrate such that the second portion of the contact is aligned with and juxtaposed to the second isolation region. In this embodiment, the first and second portions of the contact may be semiconductor materials having a first conductivity, and the first and second isolation regions may be semiconductor materials having the second conductivity.

[0018] The microelectromechanical device of this embodiment may also include a trench, disposed in the third substrate and around at least a portion of the second portion of the contact. The trench may include a first material (for example, an insulator material) disposed therein to electrically isolate the second portion of the contact from the third substrate. The trench may be aligned with and juxtaposed to the second isolation region.

[0019] Notably, all forms of bonding, whether now known or later developed, are intended to fall within the scope of the present invention. For example, bonding techniques such as fusion bonding, anodic-like bonding, silicon direct bonding, soldering (for example, eutectic soldering), thermo compression, thermo-sonic bonding, laser bonding and/or glass reflow bonding, and/or combinations thereof.

[0020] Moreover, any of the embodiments described and illustrated herein may employ a bonding material and/or a bonding facilitator material (disposed between substrates, for example, the second and third substrates) to, for example, enhance the attachment of or the "seal" between the substrates (for example, the first and second, and/or the second and third), address/compensate for planarity considerations between substrates to be bonded (for example, compensate for differences in planarity between bonded substrates), and/or to reduce and/or minimize differences in thermal expansion (that is materials having different coefficients of thermal expansion) of the substrates and materials therebetween (if any). Such materials may be, for example, solder, metals, frit, adhesives, BPSG, PSG, or SOG, or combinations thereof.

[0021] Again, there are many inventions, and aspects of the inventions, described and illustrated herein. This Summary of the Inventions is not exhaustive of the scope of the present inventions. Moreover, this Summary of the Inven-

tions is not intended to be limiting of the inventions and should not be interpreted in that manner. While certain embodiments have been described and/or outlined in this Summary of the Inventions, it should be understood that the present inventions are not limited to such embodiments, description and/or outline, nor are the claims limited in such a manner. Indeed, many others embodiments, which may be different from and/or similar to, the embodiments presented in this Summary, will be apparent from the description, illustrations and claims, which follow. In addition, although various features, attributes and advantages have been described in this Summary of the Inventions and/or are apparent in light thereof, it should be understood that such features, attributes and advantages are not required whether in one, some or all of the embodiments of the present inventions and, indeed, need not be present in any of the embodiments of the present inventions.

BRIEF DESCRIPTION OF THE DRAWINGS

[0022] In the course of the detailed description to follow, reference will be made to the attached drawings. These drawings show different aspects of the present inventions and, where appropriate, reference numerals illustrating like structures, components, materials and/or elements in different figures are labeled similarly. It is understood that various combinations of the structures, components, materials and/or elements, other than those specifically shown, are contemplated and are within the scope of the present inventions.

[0023] FIG. 1A is a block diagram representation of a mechanical structure disposed on a substrate and encapsulated via at least a second substrate;

[0024] FIG. 1B is a block diagram representation of a mechanical structure and circuitry, each disposed on one or more substrates and encapsulated via a substrate;

[0025] FIG. 2 illustrates a top view of a portion of a mechanical structure of a conventional resonator, including moveable electrode, fixed electrode, and a contact;

[0026] FIG. 3 is a cross-sectional view (sectioned along dotted line A-A' of FIG. 2) of a portion of the moveable electrode, fixed electrode, and the contact of FIG. 2 of an exemplary embodiment of the present inventions wherein the first substrate employs an SOI wafer;

[0027] FIGS. 4A-4G illustrate cross-sectional views (sectioned along dotted line A-A' of FIG. 2) of the fabrication of the mechanical structure of FIGS. 2 and 3 at various stages of an exemplary process that employs an encapsulation technique according to certain aspects of the present inventions;

[0028] FIG. 5 illustrates a cross-sectional view (sectioned along dotted line A-A' of FIG. 2) of a portion of the moveable electrode, fixed electrode, and the contact of FIG. 2, wherein microelectromechanical system includes electronic or electrical circuitry in conjunction with micromachined mechanical structure of FIG. 2, in accordance with an exemplary embodiment of the present inventions;

[0029] FIGS. 6A-6D illustrate cross-sectional views of the fabrication of the portion of the microelectromechanical system of FIG. 5 at various stages of an exemplary process that employs an encapsulation technique according to certain aspects of the present inventions;

[0030] FIGS. 7A-7C, and 8A and 8B illustrate cross-sectional views of two exemplary embodiments of the fabrication of the portion of the microelectromechanical system of FIG. 5 using processing techniques wherein

electronic or electrical circuitry (at various stages of completeness) is formed in the second substrate prior to encapsulating the mechanical structure via securing the second substrate to the first substrate;

[0031] FIG. 9 illustrates a cross-sectional view (sectioned along dotted line A-A' of FIG. 2) of a portion of the moveable electrode, fixed electrode, and the contact of FIG. 2, wherein micromachined mechanical structure of FIG. 2 includes an isolation trench to electrically isolate the contact, in accordance with an exemplary embodiment of the present inventions;

[0032] FIGS. 10A-10I illustrate cross-sectional views of the fabrication of the portion of the microelectromechanical system of FIG. 9 at various stages of an exemplary process that employs an encapsulation technique according to certain aspects of the present inventions;

[0033] FIG. 11 illustrates a cross-sectional view (sectioned along dotted line A-A' of FIG. 2) of a portion of the moveable electrode, fixed electrode, and the contact of FIG. 2, wherein micromachined mechanical structure of FIG. 2 includes isolation regions and an isolation trench (aligned therewith) to electrically isolate the contact, in accordance with an exemplary embodiment of the present inventions;

[0034] FIGS. 12A-12J illustrate cross-sectional views of the fabrication of the portion of the microelectromechanical system of FIG. 11 at various stages of an exemplary process that employs an encapsulation technique according to certain aspects of the present inventions;

[0035] FIG. 13A illustrates a cross-sectional view (sectioned along dotted line A-A' of FIG. 2) of a portion of the moveable electrode, fixed electrode, and the contact of FIG. 2, wherein micromachined mechanical structure of FIG. 2 includes isolation regions and an isolation trench (aligned therewith), including an oppositely doped semiconductor (relative to the conductivity of second substrate 14b), to electrically isolate the contact, in accordance with an exemplary embodiment of the present inventions;

[0036] FIGS. 13B and 13C illustrate cross-sectional views of the fabrication of the portion of the microelectromechanical system of FIG. 13A at various stages of an exemplary process that employs an encapsulation technique according to certain aspects of the present inventions;

[0037] FIG. 14 is a cross-sectional view (sectioned along dotted line A-A' of FIG. 2) of a portion of the moveable electrode, fixed electrode, and the contact of FIG. 2 of an embodiment of the present inventions wherein the microelectromechanical system employs three substrates;

[0038] FIGS. 15A-15H illustrate cross-sectional views (sectioned along dotted line A-A' of FIG. 2) of the fabrication of the mechanical structure of FIGS. 2 and 14 at various stages of a process that employs an encapsulation technique according to certain aspects of the present inventions;

[0039] FIG. 16 illustrates a cross-sectional view of an embodiment of the fabrication of the microelectromechanical system of FIG. 14 wherein electronic or electrical circuitry (after fabrication) is formed in the third substrate according to certain aspects of the present inventions;

[0040] FIG. 17 illustrates a cross-sectional view of an exemplary embodiment of the present inventions of the microelectromechanical system including a plurality of micromachined mechanical structures wherein a first micromachined mechanical structure is formed in the second substrate and a second micromachined mechanical structure is formed in the third substrate wherein a fourth substrate

encapsulates one or more of the micromachined mechanical structures according to certain aspects of the present inventions;

[0041] FIG. 18 illustrates a cross-sectional view of an exemplary embodiment of the present inventions of the microelectromechanical system including a plurality of micromachined mechanical structures wherein a first micromachined mechanical structure is formed in the second substrate and a second micromachined mechanical structure is formed in the third substrate wherein a fourth substrate encapsulates one or more of the micromachined mechanical structures and includes electronic or electrical circuitry according to certain aspects of the present inventions;

[0042] FIG. 19 is a cross-sectional view (sectioned along dotted line A-A' of FIG. 2) of a portion of the moveable electrode, fixed electrode, and the contact of FIG. 2 of an exemplary embodiment of the present inventions wherein the microelectromechanical system employs three substrates and cavities are formed in the first and third substrates;

[0043] FIGS. 20A-20H illustrate cross-sectional views (sectioned along dotted line A-A' of FIG. 2) of the fabrication of the mechanical structure of FIGS. 2 and 19 at various stages of an exemplary process that employs an encapsulation technique according to certain aspects of the present inventions;

[0044] FIG. 21 illustrates a cross-sectional view (sectioned along dotted line A-A' of FIG. 2) of a portion of the moveable electrode, fixed electrode, and the contact of FIG. 2, wherein the first cavity is formed in the second substrate and a second cavity is formed in a third substrate according to certain aspects of the present inventions;

[0045] FIG. 22 illustrates a cross-sectional view (sectioned along dotted line A-A' of FIG. 2) of a portion of the moveable electrode, fixed electrode, and the contact of FIG. 2, wherein the first and second cavities are formed in the second substrate, according to certain aspects of the present inventions;

[0046] FIG. 23 is a cross-sectional view (sectioned along dotted line A-A' of FIG. 2) of a portion of the moveable electrode, fixed electrode, and the contact of FIG. 2 of an exemplary embodiment of the present inventions wherein the microelectromechanical system employs three substrates and the second and third substrates include the same conductivity types;

[0047] FIGS. 24A-24I illustrate cross-sectional views of the fabrication of the portion of the microelectromechanical system of FIG. 23 at various stages of an exemplary process that employs an encapsulation technique according to certain aspects of the present inventions;

[0048] FIG. 25 is a cross-sectional view (sectioned along dotted line A-A' of FIG. 2) of a portion of the moveable electrode, fixed electrode, and the contact of FIG. 2 of an exemplary embodiment of the present inventions wherein the microelectromechanical system employs three substrates and the first and second substrates include the same conductivity types;

[0049] FIGS. 26A-26H illustrate cross-sectional views of the fabrication of the portion of the microelectromechanical system of FIG. 25 at various stages of an exemplary process that employs an encapsulation technique according to certain aspects of the present inventions;

[0050] FIG. 27 is a cross-sectional view (sectioned along dotted line A-A' of FIG. 2) of a portion of the moveable electrode, fixed electrode, and the contact of FIG. 2 of an

exemplary embodiment of the present inventions wherein the microelectromechanical system employs three substrates which include the same conductivity types;

[0051] FIGS. 28A-28I illustrate cross-sectional views of the fabrication of the portion of the microelectromechanical system of FIG. 27 at various stages of an exemplary process that employs an encapsulation technique according to certain aspects of the present inventions;

[0052] FIG. 29 is a cross-sectional view (sectioned along dotted line A-A' of FIG. 2) of a portion of the moveable electrode, fixed electrode, and the contact of FIG. 2 of an exemplary embodiment of the present inventions wherein the microelectromechanical system employs three substrates which include the same conductivity types;

[0053] FIGS. 30A-30I illustrate cross-sectional views of the fabrication of the portion of the microelectromechanical system of FIG. 29 at various stages of an exemplary process that employs an encapsulation technique according to certain aspects of the present inventions;

[0054] FIGS. 31A-31D illustrate cross-sectional views of the fabrication of the portion of the microelectromechanical system of FIG. 27 at various stages of an exemplary process that employs grinding and/or polishing to provide a desired surface, according to certain aspects of the present inventions;

[0055] FIG. 32 is a cross-sectional view (sectioned along dotted line A-A' of FIG. 2) of a portion of the moveable electrode, fixed electrode, and the contact of FIG. 2 of an exemplary embodiment of the present inventions wherein the microelectromechanical system employs three substrates;

[0056] FIGS. 33A-33I illustrate cross-sectional views of the fabrication of the portion of the microelectromechanical system of FIG. 32 at various stages of an exemplary process that employs an encapsulation technique according to certain aspects of the present inventions;

[0057] FIG. 34 is a cross-sectional view (sectioned along dotted line A-A' of FIG. 2) of a portion of the moveable electrode, fixed electrode, and the contact of FIG. 2 of an exemplary embodiment of the present inventions wherein the microelectromechanical system employs three substrates wherein an insulative layer is disposed between each of the substrates;

[0058] FIGS. 35A-35L illustrate cross-sectional views of the fabrication of the portion of the microelectromechanical system of FIG. 34 at various stages of an exemplary process that employs an encapsulation technique according to certain aspects of the present inventions;

[0059] FIG. 36 is a cross-sectional view (sectioned along dotted line A-A' of FIG. 2) of a portion of the moveable electrode, fixed electrode, and the contact of FIG. 2 of an exemplary embodiment of the present inventions wherein the microelectromechanical system employs three substrates wherein an insulative layer is disposed between two of the substrates;

[0060] FIGS. 37A-37I illustrate cross-sectional views of the fabrication of the portion of the microelectromechanical system of FIG. 36 at various stages of an exemplary process that employs an encapsulation technique according to certain aspects of the present inventions;

[0061] FIG. 38 is a cross-sectional view (sectioned along dotted line A-A' of FIG. 2) of a portion of the moveable electrode, fixed electrode, and the contact of FIG. 2 of an exemplary embodiment of the present inventions wherein

the microelectromechanical system employs three substrates wherein an insulative layer is disposed between two of the substrates and isolation trenches and regions electrically isolate the contact;

[0062] FIGS. 39A-39K illustrate cross-sectional views of the fabrication of the portion of the microelectromechanical system of FIG. 38 at various stages of an exemplary process that employs an encapsulation technique according to certain aspects of the present inventions;

[0063] FIG. 40 is a cross-sectional view (sectioned along dotted line A-A' of FIG. 2) of a portion of the moveable electrode, fixed electrode, and the contact of FIG. 2 of an exemplary embodiment of the present inventions wherein the microelectromechanical system employs three substrates wherein an intermediate layer (for example, a native oxide layer) is disposed between two of the substrates;

[0064] FIGS. 41A-41H illustrate cross-sectional views of the fabrication of the portion of the microelectromechanical system of FIG. 40 at various stages of an exemplary process that employs an encapsulation technique according to certain aspects of the present inventions;

[0065] FIGS. 42A and 42B are cross-sectional views (sectioned along dotted line A-A' of FIG. 2) of a portion of the moveable electrode, fixed electrode, and the contact of FIG. 2 of exemplary embodiments of the present inventions wherein the microelectromechanical system employs three substrates wherein an intermediate layer (for example, a native oxide layer) is disposed (for example, deposited or grown) between two of the substrates;

[0066] FIGS. 43A-43K illustrate cross-sectional views of the fabrication of the portion of the microelectromechanical systems of FIGS. 42A and 42B at various stages of an exemplary process that employs an encapsulation technique according to certain aspects of the present inventions;

[0067] FIG. 44 is a cross-sectional view (sectioned along dotted line A-A' of FIG. 2) of a portion of the moveable electrode, fixed electrode, and the contact of FIG. 2 of an exemplary embodiment of the present inventions wherein the microelectromechanical system employs three substrates and the processing techniques include alternative processing margins;

[0068] FIGS. 45A-45I illustrate cross-sectional views of the fabrication of the portion of the microelectromechanical system of FIG. 44 at various stages of an exemplary process that employs an encapsulation technique according to certain aspects of the present inventions;

[0069] FIG. 46A is a cross-sectional view (sectioned along dotted line A-A' of FIG. 2) of a portion of the moveable electrode, fixed electrode, and the contact of FIG. 2 of an exemplary embodiment of the present inventions wherein the microelectromechanical system employs three substrates and the processing techniques include alternative processing margins wherein the isolation trenches include an over etch;

[0070] FIG. 46B is a cross-sectional view (sectioned along dotted line A-A' of FIG. 2) of a portion of the moveable electrode, fixed electrode, and the contact of FIG. 2 of an exemplary embodiment of the present inventions wherein the microelectromechanical system employs three substrates and a selected trench includes alternative processing margins;

[0071] FIGS. 47A-47D and 48A-48C are cross-sectional views (sectioned along dotted line A-A' of FIG. 2) of a portion of the moveable electrode, fixed electrode, and the

contact of FIG. 2 of an embodiment of the present inventions having alternative exemplary processing techniques, flows and orders thereof;

[0072] FIGS. 49A-49G, 50A-50G and 51A-51J are cross-sectional views (sectioned along dotted line A-A' of FIG. 2) of a portion of the moveable electrode, fixed electrode, and the contact of FIG. 2 of exemplary embodiments of the present inventions having alternative processing techniques, flows and orders thereof relative to one or more of substrates;

[0073] FIG. 52 is a cross-sectional view (sectioned along dotted line A-A' of FIG. 2) of a portion of the moveable electrode, fixed electrode, and the contact of FIG. 2 of an exemplary embodiment of the present inventions wherein the microelectromechanical system employs three substrates wherein isolation regions are implanted in a cover substrate to electrically isolate the contact;

[0074] FIGS. 53A-53H illustrate cross-sectional views of the fabrication of the portion of the microelectromechanical system of FIG. 52 at various stages of an exemplary process that employs an encapsulation technique according to certain aspects of the present inventions;

[0075] FIG. 54 is a cross-sectional view (sectioned along dotted line A-A' of FIG. 2) of a portion of the moveable electrode, fixed electrode, and the contact of FIG. 2 of an exemplary embodiment of the present inventions wherein the microelectromechanical system employs three substrates wherein isolation regions include an insulation material (for example, a silicon nitride or silicon dioxide);

[0076] FIGS. 55A-55K illustrate cross-sectional views of the fabrication of the portion of the microelectromechanical system of FIG. 54 at various stages of an exemplary process that employs an encapsulation technique according to certain aspects of the present inventions;

[0077] FIG. 56 is a cross-sectional view (sectioned along dotted line A-A' of FIG. 2) of a portion of the moveable electrode, fixed electrode, and the contact of FIG. 2 of an exemplary embodiment of the present inventions wherein a contact area is etched and formed in one of the "cover" substrate to provide for electrical conductivity with the an underlying contact area;

[0078] FIGS. 57A-57J illustrate cross-sectional views of an exemplary flow of the fabrication of the portion of the microelectromechanical system of FIG. 56 at various stages of an exemplary process that employs an encapsulation technique according to certain aspects of the present inventions;

[0079] FIG. 58 is a cross-sectional view (sectioned along dotted line A-A' of FIG. 2) of a portion of the moveable electrode, fixed electrode, and the contact of FIG. 2 of an exemplary embodiment of the present inventions wherein bonding material and/or a bonding facilitator material is employed between substrates;

[0080] FIGS. 59A-59G and 59J-59L illustrate cross-sectional views of the fabrication of the portion of the microelectromechanical system of FIG. 58 at various stages of an exemplary process that employs an encapsulation technique according to certain aspects of the present inventions;

[0081] FIG. 60 is a cross-sectional view (sectioned along dotted line A-A' of FIG. 2) of a portion of the moveable electrode, fixed electrode, and the contact of FIG. 2 of another exemplary embodiment of the present inventions wherein bonding material and/or a bonding facilitator material is employed between substrates;

[0082] FIGS. 61A-61K illustrate cross-sectional views of the fabrication of the portion of the microelectromechanical system of FIG. 58 at various stages of an exemplary process that employs an encapsulation technique according to certain aspects of the present inventions;

[0083] FIGS. 62-64 illustrates cross-sectional views of several embodiments of the fabrication of microelectromechanical systems of the present inventions wherein the microelectromechanical systems include electronic or electrical circuitry formed in a substrate, according to certain aspects of the present inventions; and

[0084] FIGS. 65 and 66A-66F are block diagram illustrations of various embodiments of the microelectromechanical systems of the present inventions wherein the microelectromechanical systems includes at least three substrates wherein one or more substrates include one or more micro-machined mechanical structures and/or electronic or electrical circuitry, according to certain aspects of the present inventions.

DESCRIPTION OF THE INVENTIONS

[0085] There are many inventions described and illustrated herein. In one aspect, the present inventions relate to devices, systems and/or methods of encapsulating and fabricating electromechanical structures or elements, for example, accelerometer, gyroscope or other transducer (for example, pressure sensor, strain sensor, tactile sensor, magnetic sensor and/or temperature sensor), filter or resonator. The fabricating or manufacturing microelectromechanical systems of the present invention, and the systems manufactured thereby, employ wafer bonding encapsulation techniques.

[0086] With reference to FIGS. 1A, 1B and 2, in one exemplary embodiment, microelectromechanical device 10 includes micromachined mechanical structure 12 that is disposed on substrate 14, for example, a semiconductor, a glass, or an insulator material. The microelectromechanical device 10 may include electronics or electrical circuitry 16 (hereinafter collectively "circuitry 16") to, for example, drive mechanical structure 12, sense information from mechanical structure 12, process or analyze information generated by, and/or control or monitor the operation of micromachined mechanical structure 12. In addition, circuitry 16 (for example, CMOS circuitry) may generate clock signals using, for example, an output signal of micromachined mechanical structure 12, which may be a resonator type electromechanical structure. Under these circumstances, circuitry 16 may include frequency and/or phase compensation circuitry (hereinafter "compensation circuitry 18"), which receives the output of the resonator and adjusts, compensates, corrects and/or controls the frequency and/or phase of the output of resonator. In this regard, compensation circuitry uses the output of resonator to provide an adjusted, corrected, compensated and/or controlled output having, for example, a desired, selected and/or predetermined frequency and/or phase.

[0087] Notably, circuitry 16 may include interface circuitry to provide information (from, for example, micromachined mechanical structure 12) to an external device (not illustrated), for example, a computer, indicator/display and/or sensor.

[0088] With continued reference to FIGS. 1A, 1B and 2, micromachined mechanical structure 12 may include and/or be fabricated from, for example, materials in column IV of

the periodic table, for example silicon, germanium, carbon; also combinations of these, for example silicon germanium, or silicon carbide; also of III-V compounds for example gallium phosphide, aluminum gallium phosphide, or other III-V combinations; also combinations of III, IV, V, or VI materials, for example silicon nitride, silicon oxide, aluminum carbide, or aluminum oxide; also metallic silicides, germanides, and carbides, for example nickel silicide, cobalt silicide, tungsten carbide, or platinum germanium silicide; also doped variations including phosphorus, arsenic, antimony, boron, or aluminum doped silicon or germanium, carbon, or combinations like silicon germanium; also these materials with various crystal structures, including single crystalline, polycrystalline, nanocrystalline, or amorphous; also with combinations of crystal structures, for instance with regions of single crystalline and polycrystalline structure (whether doped or undoped).

[0089] As mentioned above, micromachined mechanical structure 12 illustrated in FIG. 2 may be a portion of an accelerometer, gyroscope or other transducer (for example, pressure sensor, strain sensor, tactile sensor, magnetic sensor and/or temperature sensor), filter or resonator. The micromachined mechanical structure 12 may also include mechanical structures of a plurality of transducers or sensors including one or more accelerometers, gyroscopes, pressure sensors, tactile sensors and temperature sensors. In the illustrated embodiment, micromachined mechanical structure 12 include moveable electrode 18.

[0090] With continued reference to FIG. 2, micromachined mechanical structure 12 may also include contact 20 disposed on or in substrate 14a. The contact 20 may provide an electrical path between micromachined mechanical structure 12 and circuitry 16 and/or an external device (not illustrated). The contact 20 may include and/or be fabricated from, for example, a semiconductor or conductive material, including, for example, silicon, (whether doped or undoped), germanium, silicon/germanium, silicon carbide, and gallium arsenide, and combinations and/or permutations thereof. Notably, micromachined mechanical structure 12 and circuitry 16 may include multiple contacts 20.

[0091] In one embodiment, the present inventions employ two or more substrates to form and encapsulate micromachined mechanical structure 12. For example, with reference to FIG. 3, in one embodiment, microelectromechanical system 10 includes semiconductor on insulator ("SOI") substrate 14a and cover substrate 14b. Briefly, by way of overview, in this embodiment, micromachined mechanical structure 12 (including moveable electrode 18 and contact 20) is formed in or on SOI substrate 14a and encapsulated via cover substrate 14b. In this regard, micromachined mechanical structure 12 is formed in the semiconductor portion of SOI substrate 14a that resides on the insulator portion of SOI substrate 14a. Thereafter, substrate 14b is secured (for example, bonded) to the exposed surface of the semiconductor portion of SOI substrate 14a to encapsulate micromachined mechanical structure 12.

[0092] In particular, with reference to FIG. 4A, microelectromechanical system 10 is formed in or on SOI substrate 14a. The SOI substrate 14a may include first substrate layer 22a (for example, a semiconductor (such as silicon), glass or sapphire), insulation layer 22b (for example, a silicon dioxide or silicon nitride layer) and first semiconductor layer 22c (for example, a materials in column IV of the periodic table, for example silicon, germanium, carbon, as well as combi-

nations of such materials, for example silicon germanium, or silicon carbide). In one embodiment, SOI substrate 14a is a SIMOX wafer. Where SOI substrate 36 is a SIMOX wafer, such wafer may be fabricated using well-known techniques including those disclosed, mentioned or referenced in U.S. Pat. Nos. 5,053,627; 5,080,730; 5,196,355; 5,288,650; 6,248,642; 6,417,078; 6,423,975; and 6,433,342 and U.S. Published Patent Applications 2002/0081824 and 2002/0123211, the contents of which are hereby incorporated by reference.

[0093] In another embodiment, SOI substrate 14a may be a conventional SOI wafer having a relatively thin semiconductor layer 22c. In this regard, SOI substrate 36 having a relatively thin semiconductor layer 22c may be fabricated using a bulk silicon wafer which is implanted and oxidized by oxygen to thereby form a relatively thin silicon dioxide layer 22b on a monocrystalline wafer surface 22a. Thereafter, another wafer (illustrated as layer 22c) is bonded to layer 22b. In this exemplary embodiment, semiconductor layer 22c (i.e., monocrystalline silicon) is disposed on insulation layer 22b (i.e. silicon dioxide), having a thickness of approximately 350 nm, which is disposed on a first substrate layer 22a (for example, monocrystalline silicon), having a thickness of approximately 190 nm.

[0094] Notably, all techniques for providing or fabricating SOI substrate 14a, whether now known or later developed, are intended to be within the scope of the present inventions.

[0095] With reference to FIGS. 4A and 4B, an exemplary method of fabricating or forming micromachined mechanical structure 12 according to this embodiment of the present inventions may begin with forming first cavity 24 in semiconductor layer 22c using well-known lithographic and etching techniques. In this way, a selected portion of semiconductor layer 22c (for example, 1 μm) is removed to form first cavity 24 (which forms a portion of the chamber in which the mechanical structure, for example, moveable electrode 18, resides).

[0096] With reference to FIGS. 4C and 4D, thereafter, moveable electrode 18 and contact area 26 are formed in semiconductor layer 22c and moveable electrode 18 is "released" from insulation layer 22b. In this regard, trenches 28a-c are formed in semiconductor layer 22c to define moveable electrode 18 and contact area 26 therefrom. (See, FIG. 4C). The trenches 28a-c may be formed using well-known deposition and lithographic techniques. Notably, all techniques for forming or fabricating trenches 28a-c, whether now known or later developed, are intended to be within the scope of the present inventions.

[0097] After moveable electrode 18 is defined via trenches 28b and 28c, moveable electrode 18 may be "released" by etching portions of insulation layer 22b that are disposed under moveable electrode 18. For example, in one embodiment, where insulation layer 22b is comprised of silicon dioxide, selected portions may be removed/etched using well-known wet etching techniques and buffered HF mixtures (i.e., a buffered oxide etch) or well-known vapor etching techniques using vapor HF. The trenches 28b and 28c, in addition to defining the features of moveable electrode 18, may also permit etching and/or removal of at least selected portions of insulation layer 22b thereby providing a void or cavity 30 beneath moveable electrode 18. (See, FIG. 4D). Proper design of mechanical structures 12 (and in particular moveable electrode 18) and control of the HF etching process parameters may permit insulation layer 22b

to be sufficiently removed or etched to release moveable electrode **18** and permit proper operation of micromachined mechanical structure **12** and microelectromechanical system **10**. Notably, cavities **24** and **30** form the chamber in which the mechanical structure, for example, moveable electrode **18**, resides.

[0098] With reference to FIG. 4E, second substrate **14b** may be fixed to the exposed portion(s) of semiconductor layer **22c**. The second substrate **14b** may be secured to the exposed portion(s) of semiconductor layer **22c** using, for example, well-known bonding techniques such as fusion bonding, anodic-like bonding and/or silicon direct bonding. Other bonding technologies are suitable including soldering (for example, eutectic soldering), thermo compression bonding, thermo-sonic bonding, laser bonding and/or glass reflow, and/or combinations thereof. Indeed, all forms of bonding, whether now known or later developed, are intended to fall within the scope of the present invention.

[0099] In conjunction with securing second substrate **14b** to the exposed portion(s) of semiconductor layer **22c**, the atmosphere (including its characteristics) in which moveable electrode **18** operates may also be defined. In this regard, the chamber in which the moveable electrode **18** reside may be defined when second substrate **14b** is secured and/or fixed to the exposed portion(s) of semiconductor layer **22c** or after further processing (for example, an annealing step may be employed to adjust the pressure). Notably, all techniques of defining the atmosphere, including the pressure thereof, during the process of securing second substrate **14b** to semiconductor layer **22c**, whether now known or later developed, are intended to be within the scope of the present inventions.

[0100] For example, second substrate **14b** may be secured to the exposed portion(s) of semiconductor layer **22c** in a nitrogen, oxygen and/or inert gas environment (for example, helium). The pressure of the fluid (gas or vapor) may be selected, defined and/or controlled to provide a suitable and/or predetermined pressure of the fluid in the chamber immediately after fixing substrate **14b** to the exposed portion (s) of semiconductor layer **22c** (in order to avoid damaging portions of micromachined mechanical structure **12**), after one or more subsequent processing steps (for example, an annealing step) and/or after completion of micromachined mechanical structure **12** and/or microelectromechanical system **10**.

[0101] Notably, the gas(es) employed during these processes may provide predetermined reactions (for example, oxygen molecules may react with silicon to provide a silicon oxide). All such techniques are intended to fall within the scope of the present inventions.

[0102] The second substrate **14b** may be formed from any material now known or later developed. In a preferred embodiment, second substrate **14b** includes or is formed from, for example, materials in column IV of the periodic table, for example silicon, germanium, carbon; also combinations of these, for example silicon germanium, or silicon carbide; also of III-V compounds for example gallium phosphide, aluminum gallium phosphide, or other III-V combinations; also combinations of III, IV, V, or VI materials, for example silicon nitride, silicon oxide, aluminum carbide, or aluminum oxide; also metallic silicides, germanides, and carbides, for example nickel silicide, cobalt silicide, tungsten carbide, or platinum germanium silicide; also doped variations including phosphorus, arsenic, anti-

mony, boron, or aluminum doped silicon or germanium, carbon, or combinations like silicon germanium; also these materials with various crystal structures, including single crystalline, polycrystalline, nanocrystalline, or amorphous; also with combinations of crystal structures, for instance with regions of single crystalline and polycrystalline structure (whether doped or undoped).

[0103] Before or after second substrate **14b** is secured to the exposed portion(s) of semiconductor layer **22c**, contact area **26b** may be formed in a portion of second substrate **14b** to be aligned with, connect to or overlie contact area **26a** in order to provide suitable, desired and/or predetermined electrical conductivity (for example, N-type or P-type) with contact area **26a** when second substrate **14b** is secured to first substrate **14a**. (See, FIG. 4F). The contact area **26b** may be formed in second substrate **14b** using well-known lithographic and doping techniques. In this way, contact area **26b** may be a highly doped region of second substrate **14b** which provides enhanced electrical conductivity with contact area **26a**.

[0104] Notably, contact area **26b** may be a counter-doped region or heavily counter-doped region of second substrate **14b** which includes a conductivity that is different from the conductivity of the other portions of second substrate **14b**. In this way, contact areas **26a** and **26b** are electrically isolated from the other portions of second substrate **14b**. Thus, in this embodiment, semiconductor layer **22c** may be a first conductivity type (for example, an N-type conductivity which may be provided, for example, via introduction of phosphorous and/or arsenic dopant(s), among others) and second substrate **14b** may be a second conductivity type (for example, a P-type conductivity which may be provided, for example, via introduction of boron dopant(s), among others). As such, contact area **26b** may be a counter-doped region or heavily counter-doped N-type region which provides suitable, desired and/or predetermined electrical conductivity characteristics when second substrate **14b** is secured to first substrate **14a** and contact areas **26a** and **26b** are in physical and electrical contact.

[0105] With reference to FIG. 4G, microelectromechanical system **10** may be completed by depositing, forming and/or growing insulation layer **32** and a contact opening may be etched to facilitate electrical contact/connection to contact area **26b**, via conductive layer **34** (for example, a heavily doped polysilicon, metal (such as aluminum, chromium, gold, silver, molybdenum, platinum, palladium, tungsten, titanium, and/or copper), metal stacks, complex metals and/or complex metal stacks) may then be deposited (and/or formed) to provide the appropriate electrical connection to contact areas **26** (which includes, in this example, contact areas **26a** and **26b**).

[0106] Notably, insulation layer **32** and/or conductive layer **34** may be formed, grown and/or deposited before or after second substrate **14b** is secured to the exposed portion (s) of semiconductor layer **22c**. Under these circumstances, when second substrate **14b** is secured to first substrate **14a**, the microelectromechanical system **10** may be completed.

[0107] The insulating layer **32** may be, for example, silicon dioxide, silicon nitride, BPSG, PSG, or SOG, or combinations thereof. It may be advantageous to employ silicon nitride because silicon nitride may be deposited in a more conformal manner than silicon oxide. Moreover, sili-

con nitride is compatible with CMOS processing, in the event that microelectromechanical system 10 includes CMOS integrated circuits.

[0108] Notably, prior to formation, deposition and/or growth of insulation layer 32 and/or conductive layer 34, additional micromachined mechanical structures 12 and/or transistors of circuitry 16 may be formed and/or provided in second substrate 14b or in other substrates that may be fixed to first substrate 14a and/or second substrate 14b. In this regard, the exposed surface of second substrate 14b may be a suitable base upon which integrated circuits (for example, CMOS transistors) and/or micromachined mechanical structures 12 may be fabricated on or in. Such integrated circuits may be fabricated using well-known techniques and equipment. For example, with reference to FIG. 5, in one embodiment, transistor regions 36, which may be integrated circuits (for example, CMOS transistors) of circuitry 16, may be provided in second substrate 14b. The transistor regions 36 may be formed before or after second substrate 14b is secured (for example, bonded) to first substrate 14a. In this regard, with reference to FIG. 6A, transistor implants 38 may be formed using well-known lithographic and implant processes, after second substrate 14b is secured to first substrate 14a and concurrently with the formation of contact area 26b.

[0109] Thereafter, conventional transistor processing (for example, formation of gate and gate insulator 40) may be employed to complete the transistors of circuitry 16. (See, FIG. 6B). The “back-end” processing of microelectromechanical system 10 (for example, formation, growth and/or deposition of insulation layer 32 and conductive layer 34) may be performed using the same processing techniques as described above. (See, for example, FIGS. 6C and 6D). In this regard, insulation layer 32 may be deposited, formed and/or grown and patterned and, thereafter, conductive layer 34 (for example, a heavily doped polysilicon, metal (such as aluminum, chromium, gold, silver, molybdenum, platinum, palladium, tungsten, titanium, and/or copper), metal stacks, complex metals and/or complex metal stacks) is deposited and/or formed. In the illustrative embodiments, contact 20 is accessed directly by the transistors of circuitry 16 via conductive layer 34. Here, conductive layer 34 may be a low resistance electrical path that is deposited and patterned to facilitate connection of micromachined mechanical structure 12 and circuitry 16.

[0110] As noted above, the transistors of transistor region 36 may be formed prior to securing second substrate 14b to first substrate 14a. (See, for example, FIGS. 7A and 7B). Indeed, all of the “back-end” processing, in addition to formation of the transistors of transistor region 36, may be completed prior to securing second substrate 14b to first substrate 14a. (See, for example, FIGS. 8A and 8B).

[0111] With reference to FIGS. 9, 10A-10I, 11 and 12A-12J, in another embodiment of the present inventions, semiconductor layer 22c of SOI substrate 14a is the same conductivity as second substrate 14b. In these embodiments, micromachined mechanical structure 12 may include additional features to electrically isolate contact 20. For example, with reference to FIG. 9, in one embodiment, micromachined mechanical structure 12 includes isolation trenches 42a and 42b that isolates contact 20 (and contact areas 26a and 26b) from portions of second substrate 14b. The isolation trenches 42a and 42b may include an insulator material, for example, silicon dioxide or silicon nitride.

Indeed, as illustrated, material that forms insulation layer 32 may also be deposited in isolation trenches 42a and 42b. Notably, FIGS. 10A-10I illustrate an exemplary process flow for fabricating microelectromechanical system 10 of FIG. 9.

[0112] With reference to FIG. 11, in another exemplary embodiment, isolation regions 44a and 44b are deposited and/or implanted into portions of semiconductor layer 22c of SOI substrate 14a in order to facilitate electrical isolation of contact 20 after second substrate 14b is secured or fixed (via, for example, bonding). The isolation regions 44a and 44b may be any material or structure that insulates contact 20, for example, an insulator material and/or an oppositely doped semiconductor region. FIGS. 12A-12J illustrate an exemplary process flow for fabricating microelectromechanical system 10 of FIG. 11 wherein isolation regions 44a and 44b are oppositely doped semiconductor regions and an insulation material is disposed in isolation trenches 42a and 42b.

[0113] FIG. 13A illustrates an exemplary microelectromechanical system 10 wherein the isolation regions 44a and 44b are oppositely doped semiconductor regions (relative to the conductivity of second substrate 14b) and a semiconductor, having a conductivity different from the conductivity of the semiconductor of second substrate 14b, is disposed (for example using epitaxial deposition techniques) in isolation trenches 42a and 42b. FIGS. 13B and 13C illustrate selected portions of an exemplary process flow for fabricating microelectromechanical system 10 of FIG. 13A.

[0114] Notably, the embodiments of FIGS. 9, 11 and 13A may also include circuitry 16 disposed in second substrate 14b. The fabrication techniques described above and illustrated in FIGS. 5-8B may be employed in the embodiments of FIGS. 9 and 11. Indeed, prior to or after formation, deposition and/or growth of insulation layer 32 and/or conductive layer 34, additional micromachined mechanical structures 12 and/or transistors of circuitry 16 may be formed and/or provided in second substrate 14b or in other substrates that may be fixed to first substrate 14a and/or second substrate 14b. For the sake of brevity, those discussions, in connection with the embodiments of FIGS. 9, 11 and 13A, will not be repeated.

[0115] The present inventions may also employ more than two substrates to form and encapsulate micromachined mechanical structure 12. For example, with reference to FIG. 14, in one embodiment, microelectromechanical system 10 includes first substrate 14a, second substrate 14b and third substrate 14c. Briefly, by way of overview, in this embodiment, micromachined mechanical structure 12 (including moveable electrode 18 and contact 20) is formed in second substrate 14b and encapsulated via third substrate 14c. In this regard, micromachined mechanical structure 12 is formed in a portion of substrate 14b. Thereafter, substrate 14c is secured (for example, bonded) to exposed surface of substrate 14b to encapsulate micromachined mechanical structure 12. In this embodiment, the portion of substrate 14b in which micromachined mechanical structure 12 is formed includes a conductivity that is different from the conductivity of the semiconductor of first substrate 14a and third substrate 14c.

[0116] With reference to FIGS. 15A and 15B, an exemplary method of fabricating or forming micromachined mechanical structure 12 according to this embodiment of the present inventions may begin with forming first cavity 24 in

first substrate **14a** using well-known lithographic and etching techniques. In one exemplary embodiment, first cavity **24** includes a depth of about 1 μm .

[0117] With reference to FIGS. **15C** and **15D**, second substrate **14b** may be fixed to first substrate **14a**. The second substrate **14b** may be secured to the exposed portion(s) of first substrate **14a** using, for example, well-known bonding techniques such as fusion bonding, anodic-like bonding and/or silicon direct bonding. As mentioned above, other bonding technologies are suitable including soldering (for example, eutectic soldering), thermo compression bonding, thermo-sonic bonding, laser bonding and/or glass reflow, and/or combinations thereof. Indeed, all forms of bonding, whether now known or later developed, are intended to fall within the scope of the present invention.

[0118] Before or after securing second substrate **14b** to first substrate **14a**, second cavity **30** may be formed in second substrate **14b**—again using well-known lithographic and etching techniques. In one exemplary embodiment, second cavity **30** also includes a depth of about 1 μm . Thereafter, the thickness of second substrate **14b** may be adjusted to accommodate further processing. For example, second substrate **14b** may be grinded and polished (using, for example, well known chemical mechanical polishing (“CMP”) techniques) to a thickness of between 10 μm -30 μm . Notably, cavities **24** and **30** form the chamber in which the mechanical structure, for example, moveable electrode **18**, resides.

[0119] The second substrate **14b** may be formed from any material now known or later developed. In a preferred embodiment, second substrate **14b** includes or is formed from, for example, materials in column IV of the periodic table, for example silicon, germanium, carbon; also combinations of these, for example silicon germanium, or silicon carbide; also of III-V compounds for example gallium phosphide, aluminum gallium phosphide, or other III-V combinations; also combinations of III, IV, V, or VI materials, for example silicon nitride, silicon oxide, aluminum carbide, or aluminum oxide; also metallic silicides, germanides, and carbides, for example nickel silicide, cobalt silicide, tungsten carbide, or platinum germanium silicide; also doped variations including phosphorus, arsenic, antimony, boron, or aluminum doped silicon or germanium, carbon, or combinations like silicon germanium; also these materials with various crystal structures, including single crystalline, polycrystalline, nanocrystalline, or amorphous; also with combinations of crystal structures, for instance with regions of single crystalline and polycrystalline structure (whether doped or undoped).

[0120] With reference to FIG. **15E**, moveable electrode **18** and contact area **26** are defined and formed in second substrate **14b**. In this regard, trenches **28a-c** are formed in second substrate **14b** to define moveable electrode **18** and contact area **26** therefrom. (See, FIG. **15E**). The trenches **28a-c** may be formed using well-known deposition and lithographic techniques. Notably, all techniques for forming or fabricating trenches **28a-c**, whether now known or later developed, are intended to be within the scope of the present inventions.

[0121] Thereafter, third substrate **14c** may be fixed to the exposed portion(s) of second substrate **14b**. (See, FIG. **15F**). The third substrate **14c** may also be secured to the exposed portion(s) of second substrate **14b** using, for example, well-known bonding techniques such as fusion bonding,

anodic-like bonding and/or silicon direct bonding. In conjunction with securing third substrate **14c** to second substrate **14b**, the atmosphere (including its characteristics) in which moveable electrode **18** operates may also be defined—for example, as described above. Notably, all techniques of defining the atmosphere, including the pressure thereof, during the process of securing third substrate **14c** to second substrate **14b**, whether now known or later developed, are intended to be within the scope of the present inventions.

[0122] The third substrate **14c** may be formed from any material discussed above relative to second substrate **14b**. For the sake of brevity, such discussions will not be repeated.

[0123] Before or after third substrate **14c** is secured to second substrate **14b**, contact area **26b** may be formed in a portion of third substrate **14c** to be aligned with, connect to or overlie contact area **26a**. The contact area **26b** may be a semiconductor region that includes a doping that provides the same conductivity as contact area **26a**. In this way, a suitable, desired and/or predetermined electrical conductivity is provided with contact area **26a** when third substrate **14c** is secured to second substrate **14b**. (See, FIG. **15G**). Thus, contact area **26b** may be a highly doped region of third substrate **14c** which provides enhanced electrical conductivity with contact area **26a**. The contact area **26b** may be formed in third substrate **14c** using well-known lithographic and doping techniques.

[0124] Notably, contact area **26b** may be a counter-doped region or heavily counter-doped region of third substrate **14c** which includes a conductivity that is different from the conductivity of the other portions of third substrate **14c**. In this way, contact areas **26a** and **26b** are electrically isolated from the other portions of third substrate **14c**. Thus, in this embodiment, second substrate **14b** may be a first conductivity type (for example, an N-type conductivity) and third substrate **14c** may be a second conductivity type (for example, a P-type conductivity). As such, contact area **26b** may be a counter-doped region or heavily counter-doped N-type region which provides suitable, desired and/or predetermined electrical conductivity characteristics when third substrate **14c** is secured to second substrate **14b** and contact areas **26a** and **26b** are in physical contact.

[0125] With reference to FIG. **15H**, microelectromechanical system **10** may be completed by depositing, forming and/or growing insulation layer **32** and a contact opening may be etched to facilitate electrical contact/connection to contact area **26b**. The conductive layer **34** (for example, a heavily doped polysilicon, metal (such as aluminum, chromium, gold, silver, molybdenum, platinum, palladium, tungsten, titanium, and/or copper), metal stacks, complex metals and/or complex metal stacks) may then be deposited to provide the appropriate electrical connection to contact **26a** and **26b**.

[0126] Notably, insulation layer **32** and/or conductive layer **34** may be formed, grown and/or deposited before or after third substrate **14c** is secured to second substrate **14b**. Under these circumstances, when third substrate **14c** is secured to second substrate **14b**, the microelectromechanical system **10** may be completed.

[0127] The insulating layer **32** may be, for example, silicon dioxide, silicon nitride, BPSG, PSG, or SOG, or combinations thereof. It may be advantageous to employ silicon nitride because silicon nitride may be deposited in a

more conformal manner than silicon oxide. Moreover, silicon nitride is compatible with CMOS processing, in the event that microelectromechanical system 10 includes CMOS integrated circuits.

[0128] As mentioned above with respect to other embodiments of the present inventions, prior to formation, deposition and/or growth of insulation layer 32 and/or conductive layer 34, additional micromachined mechanical structures 12 and/or transistors of circuitry 16 may be formed and/or provided in third substrate 14c or in other substrates that may be fixed to first substrate 14a and/or second substrate 14b. (See, for example, FIGS. 16, 17 and 18). In this regard, the exposed surface of third substrate 14c or another substrate disposed thereon may be a suitable base upon which integrated circuits (for example, CMOS transistors) (see, FIG. 16) and/or micromachined mechanical structures 12 (see, FIGS. 17 and 18). Such integrated circuits and micromachined mechanical structures 12 may be fabricated using the inventive techniques described herein and/or well-known fabrication techniques and equipment.

[0129] For example, with reference to FIG. 16, in one embodiment, transistor regions 36 (which may be integrated circuits (for example, CMOS transistors) of circuitry 16) may be provided in second substrate 14b. The transistor regions 36 may be formed before or after third substrate 14c is secured (for example, bonded) to second substrate 14b. The fabrication techniques described above and illustrated in FIGS. 5-8B may be employed in the embodiments of FIG. 14. Indeed, prior to or after formation, deposition and/or growth of insulation layer 32 and/or conductive layer 34, additional micromachined mechanical structures 12 and/or transistors of circuitry 16 may be formed and/or provided in second substrate 14b or in other substrates that may be fixed to first substrate 14a and/or second substrate 14b. For the sake of brevity, those discussions, in connection with the embodiments of FIG. 15, will not be repeated.

[0130] Notably, although second cavity 30 is described and illustrated in the previous embodiment as being formed in second substrate 14b, second cavity 30 may be formed in third substrate 14c, as illustrated in FIGS. 19 and 20A-20H. Indeed, a portion of second cavity 30 may be formed in second substrate 14b and a portion of second cavity 30 may be formed in third substrate 14c.

[0131] Similarly, first cavity 24 may be formed in second substrate 14b, as illustrated in FIG. 21. Indeed, first cavity 24 and second cavity 30 may both be formed in second substrate 14b. (See, for example, FIG. 22). Moreover, a portion of first cavity 24 may be formed in first substrate 14a and a portion of first cavity 24 may be formed in second substrate 14b. Indeed, all permutations of formation of first cavity 24 and second cavity 30 are intended to fall within the scope of the present inventions.

[0132] With reference to FIGS. 23-30I, in another embodiment of the present inventions, first substrate 14a and/or third substrate 14c are/is the same conductivity as second substrate 14b. In these embodiments, micromachined mechanical structure 12 may include additional features to electrically isolate contact 20. For example, with reference to FIG. 23, in one embodiment, second substrate 14b is a semiconductor having the same conductivity as the conductivity of third substrate 14c. In this embodiment, micromachined mechanical structure 12 includes isolation trenches 42a and 42b that isolates contact 20 (and contact areas 26a and 26b) from portions of third substrate 14c. In this

exemplary embodiment, the isolation trenches are aligned with isolation regions 44a and 44b which are disposed in or on second substrate 14b.

[0133] The isolation trenches 42a and 42b may include a material that insulates contact 20 (and contact areas 26a and 26b) from portions of third substrate 14c. In the exemplary embodiment of FIG. 23, an insulating material, for example, silicon dioxide or silicon nitride, is deposited and/or grown in isolation trenches 42a and 42b. Indeed, as illustrated, material that forms insulation layer 32 may also be deposited in isolation trenches 42a and 42b. Notably, FIGS. 24A-24I illustrate an exemplary process flow for fabricating microelectromechanical system 10 of FIG. 23.

[0134] As mentioned above, isolation regions 44a and 44b which are disposed in or on second substrate 14b. The isolation regions 44a and 44b may be any material or structure that insulates contact 20, for example, an insulator material and/or an oppositely doped semiconductor region. In the exemplary embodiment of FIG. 23, isolation regions 44a and 44b includes oppositely doped semiconductor material.

[0135] With reference to FIG. 25, in another exemplary embodiment, first substrate 14a is a semiconductor having the same conductivity as the conductivity of second substrate 14b. In this embodiment, micromachined mechanical structure 12 includes an isolation region 44 that isolates contact 20 (and, in particular, contact area 26a) from portions of first substrate 14a. In this exemplary embodiment, the isolation region 44 is aligned with cavity 24 and trench 28a in order to provide suitable contact isolation. The isolation region 44 may include any material or structure that insulates contact 20, for example, an insulator material and/or an oppositely doped semiconductor region. In the exemplary embodiment of FIG. 25, isolation regions 44a and 44b includes oppositely doped semiconductor material. Notably, FIGS. 26A-26H illustrate an exemplary process flow for fabricating microelectromechanical system 10 of FIG. 25.

[0136] In another exemplary embodiment, first, second and third substrates 14a, 14b and 14c include semiconductor regions having the same conductivity. With reference to FIG. 27, in this embodiment, micromachined mechanical structure 12 includes an isolation trenches 42a and 42b as well as isolation regions 44a, 44b, and 44c. The isolation trenches 42a and 42b, and isolation regions 44a, 44b, and 44c, in combination, electrically isolate contact 20 (and, in particular, contact areas 26a and 26b) from contiguous portions of first substrate 14a and third substrates 14c. In this exemplary embodiment, the isolation region 44a is aligned with cavity 24 and trench 28a, and isolation trenches 42a and 42b are aligned with isolation regions 44b and 44c. In this way, contact 20 includes suitable contact isolation.

[0137] The isolation trenches 42a and 42b may include any material that insulates contact 20 (and contact areas 26a and 26b) from portions of third substrate 14c. In the exemplary embodiment of FIG. 27, an oppositely doped semiconductor is deposited and/or grown in isolation trenches 42a and 42b.

[0138] The isolation regions 44a, 44b and 44c may be disposed in or on first substrate 14a and/or second substrate 14b. In the exemplary embodiment of FIG. 27, isolation regions 44a and 44b includes oppositely doped semicon-

ductor material. Notably, FIGS. 28A-28I illustrate an exemplary process flow for fabricating microelectromechanical system 10 of FIG. 23.

[0139] As mentioned above, isolation trenches 42a and 42b may include any material or structure that insulates contact 20, for example, an insulator material and/or an oppositely doped semiconductor region. With reference to FIGS. 29 and 30A-30I, isolation trenches 42a and 42b may include an insulating material (for example, silicon dioxide or silicon nitride) which is deposited and/or grown in isolation trenches 42a and 42b. As illustrated, material that forms insulation layer 32 may also be deposited in isolation trenches 42a and 42b. In this regard, FIGS. 30A-30I illustrate an exemplary process flow for fabricating microelectromechanical system 10 of FIG. 29.

[0140] Although not previously illustrated, the present inventions may employ grinding and polishing (using, for example, well known chemical mechanical polishing ("CMP") techniques at various stages in order to, for example, provide a desired surface and/or thickness. For example, with reference to FIGS. 31A-31D, where material 46 is deposited and/or grown in isolation trenches 42a and 42b, the exposed surface may be subjected to grinding and polishing in order to remove a portion of the deposited and/or grown material from the upper surface of substrate 14c. With reference to FIG. 31C, after grinding and polishing, the surface is prepared for further processing, for example, "back-end" processing (see, for example, FIG. 31D) or incorporation of additional micromachined mechanical structures 12 and/or transistors of circuitry 16.

[0141] Notably, it may be advantageous to employ isolation trenches 42 and isolation regions 44 in the embodiments where substrates 14a and 14c include a conductivity that is different from the conductivity of substrate 14b. (See, for example, FIG. 32 and FIGS. 33A-33I). In this embodiment, isolation trenches 42 and isolation regions 44 provide additional electrical isolation for contact 20. All permutations and/or combinations of such features are intended to fall within the scope of the present inventions.

[0142] The embodiments of FIGS. 23, 25, 27, 29 and 32 may also include circuitry 16 disposed in third substrate 14c. The fabrication techniques described above and illustrated in FIGS. 5-8B may be employed in the embodiments of FIGS. 23, 25, 27, 29 and 32. Indeed, prior to or after formation, deposition and/or growth of insulation layer 32 and/or conductive layer 34, additional micromachined mechanical structures 12 and/or transistors of circuitry 16 may be formed and/or provided in third substrate 14c or in other substrates that may be fixed to first substrate 14a and/or second substrate 14b. For the sake of brevity, those discussions, in connection with the embodiments of FIGS. 23, 25, 27, 29 and 32, will not be repeated.

[0143] In another aspect, the present inventions may employ an insulative layer between the substrate in which the micromachined mechanical structures 12 resides and one or more opposing or juxtaposed substrates. Such a configuration may provide certain processing advantages as well as enhance the electrical isolation of the micromachined mechanical structures 12 from one or more opposing or juxtaposed substrates. For example, with reference to FIG. 34, in this exemplary embodiment, micromachined mechanical structure 12 (including moveable electrode 18 and contact 20) is formed in second substrate 14b and encapsulated via third substrate 14c. In this regard, micro-

machined mechanical structure 12 is formed in a portion of substrate 14b. Thereafter, substrate 14c is secured (for example, bonded) to exposed surface of substrate 14b to encapsulate micromachined mechanical structure 12. In this embodiment, insulative layers 48a (having a thickness of about 1 μm) is disposed and patterned on first substrate 14a to provide cavity 24 when second substrate 14b is disposed thereon. Similarly, insulative layer 48b (having a thickness of about 1 μm) is disposed and patterned on second substrate 14b to provide cavity 30 when third substrate 14c is disposed thereon. Notably, substrate 14a, 14b and 14c may include the same or different conductivities.

[0144] The insulative layers 48a and 48b may include, for example, an insulation material (for example, a silicon dioxide, nitride, BPSG, PSG, or SOG, or combinations thereof). It may be advantageous to employ silicon nitride because silicon nitride may be deposited, formed and/or grown in a more conformal manner than silicon oxide. Moreover, silicon nitride is compatible with CMOS processing, in the event that microelectromechanical system 10 includes CMOS integrated circuits in one or more of substrates 14 thereof.

[0145] With reference to FIGS. 35A-35C, an exemplary method of fabricating or forming micromachined mechanical structure 12 according to this embodiment of the present inventions may begin with depositing, forming and/or growing insulative layer 48a on first substrate 14a. Thereafter, first cavity 24 is formed in insulative layer 48a using well-known lithographic and etching techniques. The thickness and characteristics of insulative layer 48a may be adjusted to accommodate further processing. For example, insulative layer 48a may be polished (using, for example, well known CMP techniques) to provide a smooth planar surface for receipt of second substrate 14b and provide a desired depth of first cavity 24. In one exemplary embodiment, first cavity 24 includes a depth of about 1 μm .

[0146] With reference to FIGS. 35D-35G, second substrate 14b may be fixed to insulative layer 48a using, for example, well-known bonding techniques such as fusion bonding and/or anodic-like bonding. The insulative layer 48b may then be deposited, formed and/or grown on first substrate 14b. The second cavity 30 may then be formed in insulative layer 48b—again using well-known lithographic and etching techniques. Thereafter, the thickness and characteristics of insulative layer 48b may be adjusted to accommodate further processing. For example, insulative layer 48b may be polished (using, for example, well known CMP techniques) to provide a smooth planar surface for receipt of second substrate 14c and provide a desired depth of second cavity 30. In one exemplary embodiment, second cavity 24 includes a depth of about 1 μm .

[0147] In addition to forming second cavity 24 in insulative layer 48b, contact trench window 50 is also formed therein. (See, FIG. 35G). In this way, trench 28a may be formed concurrently with providing trenches 28b and 28c which permits definition of contact are 26a and moveable electrode 18 simultaneously. The trenches 28a-c may be formed using well-known deposition and lithographic techniques. Notably, all techniques for forming or fabricating trenches 28a-c, whether now known or later developed, are intended to be within the scope of the present inventions.

[0148] Notably, the first and second substrates 14b may be formed from any material now known or later developed. In a preferred embodiment, second substrate 14b includes or is

formed from, for example, materials in column IV of the periodic table, for example silicon, germanium, carbon; also combinations of these, for example silicon germanium, or silicon carbide; also of III-V compounds for example gallium phosphide, aluminum gallium phosphide, or other III-V combinations; also combinations of III, IV, V, or VI materials, for example silicon nitride, silicon oxide, aluminum carbide, or aluminum oxide; also metallic silicides, germanides, and carbides, for example nickel silicide, cobalt silicide, tungsten carbide, or platinum germanium silicide; also doped variations including phosphorus, arsenic, antimony, boron, or aluminum doped silicon or germanium, carbon, or combinations like silicon germanium; also these materials with various crystal structures, including single crystalline, polycrystalline, nanocrystalline, or amorphous; also with combinations of crystal structures, for instance with regions of single crystalline and polycrystalline structure (whether doped or undoped).

[0149] Thereafter, third substrate **14c** may be secured to the exposed portion(s) of insulative layer **48b**. (See, FIG. 35H). The third substrate **14b** may be secured using, for example, well-known bonding techniques such as fusion bonding and/or anodic-like bonding. In conjunction with securing third substrate **14c** to second substrate **14b**, the atmosphere (including its characteristics) in which moveable electrode **18** operates may also be defined. Notably, all techniques of defining the atmosphere, including the pressure thereof, during the process of securing third substrate **14c** to insulative layer **48b**, whether now known or later developed, are intended to be within the scope of the present inventions.

[0150] The third substrate **14c** may be formed from any material discussed above relative to first substrate **14a** and/or second substrate **14b**. For the sake of brevity, such discussions will not be repeated.

[0151] With reference to FIGS. 35I and 35J, after third substrate **14c** is secured to insulative layer **48b**, contact area **26b** may be formed. In this regard, contact area window **52** is formed in third substrate **14c** and insulative layer **48b** to expose a portion of contact area **26a**. Such processing may be performed using well-known lithographic and etching techniques. For example, in one embodiment, where third substrate **14c** is a semiconductor material (for example silicon), a portion of may be removed using reactive ion etching. Thereafter, a portion of insulative layer **48b** may be removed to expose contact area **26b**. In this regard, where insulative layer **48b** is comprised of silicon dioxide, selected portions may be removed/etched using well-known wet etching techniques and buffered HF mixtures (i.e., a buffered oxide etch) or well-known vapor etching techniques using vapor HF.

[0152] The contact area **26b** may be deposited, formed and/or grown in contact area window **52**. The contact area **26b** may be an epitaxially deposited semiconductor that includes a doping that provides the same conductivity as contact area **26a**. In this way, a suitable, desired and/or predetermined electrical conductivity is provided with contact area **26a** when third substrate **14c** is secured to second substrate **14b**. (See, FIG. 35K). Thus, contact area **26b** may be a highly doped polysilicon region which provides enhanced electrical conductivity with contact area **26a**.

[0153] As mentioned above, although not illustrated, the present inventions may employ grinding and polishing (using, for example, well known chemical mechanical polish-

ing ("CMP") techniques at various stages in order to, for example, provide a desired surface and/or thickness. (See, for example, FIGS. 31A-31D). The formation of contact area **26b** will likely employ such processing in order to provide the cross-sectional view of FIG. 35K.

[0154] With reference to FIG. 35L, microelectromechanical system **10** may be completed by depositing, forming and/or growing insulation layer **32** and a contact opening may be etched to facilitate electrical contact/connection to contact area **26b**. The conductive layer **34** (for example, a heavily doped polysilicon, metal (such as aluminum, chromium, gold, silver, molybdenum, platinum, palladium, tungsten, titanium, and/or copper), metal stacks, complex metals and/or complex metal stacks) may then be deposited to provide appropriate electrical connection to contact **26a** and **26b**.

[0155] Notably, insulation layer **32** and/or conductive layer **34** may be formed, grown and/or deposited before or after third substrate **14c** is secured to second substrate **14b**. Under these circumstances, when third substrate **14c** is secured to second substrate **14b**, the microelectromechanical system **10** may be completed.

[0156] The insulating layer **32** may be, for example, silicon dioxide, silicon nitride, BPSG, PSG, or SOG, or combinations thereof. It may be advantageous to employ silicon nitride because silicon nitride may be deposited in a more conformal manner than silicon oxide. Moreover, silicon nitride is compatible with CMOS processing, in the event that microelectromechanical system **10** includes CMOS integrated circuits.

[0157] As mentioned above with respect to other embodiments of the present inventions, prior to formation, deposition and/or growth of insulation layer **32** and/or conductive layer **34**, additional micromachined mechanical structures **12** and/or transistors of circuitry **16** may be formed and/or provided in third substrate **14c** or in other substrates that may be fixed to first substrate **14a** and/or second substrate **14b**. In this regard, the exposed surface of third substrate **14c** or another substrate disposed thereon may be a suitable base upon which integrated circuits (for example, CMOS transistors) and/or micromachined mechanical structures **12**. Such integrated circuits and micromachined mechanical structures **12** may be fabricated using the inventive techniques described herein and/or well-known fabrication techniques and equipment. For the sake of brevity, those discussions, in connection with the embodiments of FIGS. 34 and 35A-L, will not be repeated.

[0158] With reference to FIGS. 36 and 37A-37I, in another exemplary embodiment, microelectromechanical system **10** may be formed using at least three substrates **14a-c** and insulative layer **48a** disposed between substrates **14a** and **14b**. In this embodiment, the portion of substrate **14b** in which micromachined mechanical structure **12** is formed includes a cavity (like that of previous embodiments) as well as a conductivity that is different from the conductivity of the semiconductor of third substrate **14c**.

[0159] Briefly, with reference to FIGS. 35A-35C, an exemplary method of fabricating or forming micromachined mechanical structure **12** according to this embodiment of the present inventions may begin with depositing, forming and/or growing insulative layer **48a** on first substrate **14a**. As mentioned above, insulative layer **48a** may include, for

example, an insulation material (for example, a silicon dioxide, nitride, BPSG, PSG, or SOG, or combinations thereof).

[0160] Thereafter, first cavity 24 is formed in insulative layer 48a using well-known lithographic and etching techniques. (See, FIG. 37C). The thickness and characteristics of insulative layer 48a may be adjusted to accommodate further processing. For example, insulative layer 48a may be polished (using, for example, well known CMP techniques) to provide a smooth planar surface for receipt of second substrate 14b and provide a desired depth of first cavity 24. In one exemplary embodiment, first cavity 24 includes a depth of about 1 μm .

[0161] With reference to FIGS. 37D and 37E, second substrate 14b may be fixed to insulative layer 48a using, for example, well-known bonding techniques such as fusion bonding and/or anodic-like bonding. Before or after securing second substrate 14b to first substrate 14a, second cavity 30 may be formed in second substrate 14b using well-known lithographic and etching techniques. In one exemplary embodiment, second cavity 30 also includes a depth of about 1 μm . Thereafter, the thickness of second substrate 14b may be adjusted to accommodate further processing. For example, second substrate 14b may be grinded and polished (using, for example, well known chemical mechanical polishing ("CMP") techniques) to a thickness of between 10 μm -30 μm .

[0162] With reference to FIG. 37F, trenches 28a-c may be formed to define moveable electrode 18 and contact area 26a. The trenches may be formed using well-known deposition and lithographic techniques. Notably, all techniques for forming or fabricating trenches 28a-c, whether now known or later developed, are intended to be within the scope of the present inventions.

[0163] The first and second substrates 14a and 14b may be formed from any material discussed above relative to first substrate 14a and/or second substrate 14b of other embodiments. For the sake of brevity, such discussions will not be repeated.

[0164] Thereafter, third substrate 14c may be secured to the exposed portion(s) of second substrate 14b. (See, FIG. 35G). The third substrate 14b may be secured using, for example, well-known bonding techniques such as fusion bonding, anodic-like bonding and/or silicon direct bonding. In conjunction with securing third substrate 14c to second substrate 14b, the atmosphere (including its characteristics) in which moveable electrode 18 operates may also be defined. Notably, all techniques of defining the atmosphere, including the pressure thereof, during the process of securing third substrate 14c to second substrate 14b, whether now known or later developed, are intended to be within the scope of the present inventions.

[0165] Like first and second substrates 14a and 14b, third substrate 14c may be formed from any material discussed above relative to first, second and/or third substrates of other embodiments. For the sake of brevity, such discussions will not be repeated.

[0166] Before or after third substrate 14c is secured to second substrate 14b, contact area 26b may be formed in a portion of third substrate 14c to be aligned with, connect to or overlie contact area 26a. The contact area 26b may be a semiconductor region that includes a doping that provides the same conductivity as contact area 26a. In this way, a suitable, desired and/or predetermined electrical conductiv-

ity is provided with contact area 26a when third substrate 14c is secured to second substrate 14b. (See, FIG. 37H). Thus, contact area 26b may be a highly doped region of third substrate 14c which provides enhanced electrical conductivity with contact area 26a. The contact area 26b may be formed in third substrate 14c using well-known lithographic and doping techniques.

[0167] Notably, contact area 26b may be a heavily counter-doped region of third substrate 14c which includes a conductivity that is different from the conductivity of the other portions of third substrate 14c. In this way, contact areas 26a and 26b are electrically isolated from the other portions of third substrate 14c. Thus, in this embodiment, second substrate 14b may be a first conductivity type (for example, an N-type conductivity) and third substrate 14c may be a second conductivity type (for example, a P-type conductivity). As such, contact area 26b may be a heavily counter-doped N-type region which provides suitable, desired and/or predetermined electrical conductivity characteristics when third substrate 14c is secured to second substrate 14b and contact areas 26a and 26b are in physical contact.

[0168] With reference to FIG. 37I, microelectromechanical system 10 may be completed by depositing, forming and/or growing insulation layer 32 and a contact opening may be etched to facilitate electrical contact/connection to contact area 26b. The conductive layer 34 (for example, a heavily doped polysilicon, metal (such as aluminum, chromium, gold, silver, molybdenum, platinum, palladium, tungsten, titanium, and/or copper), metal stacks, complex metals and/or complex metal stacks) may then be deposited to provide appropriate electrical connection to contact 26a and 26b.

[0169] Notably, insulation layer 32 and/or conductive layer 34 may be formed, grown and/or deposited before or after third substrate 14c is secured to second substrate 14b. Under these circumstances, when third substrate 14c is secured to second substrate 14b, the microelectromechanical system 10 may be completed.

[0170] The insulating layer 32 may be, for example, silicon dioxide, silicon nitride, BPSG, PSG, or SOG, or combinations thereof. It may be advantageous to employ silicon nitride because silicon nitride may be deposited in a more conformal manner than silicon oxide. Moreover, silicon nitride is compatible with CMOS processing, in the event that microelectromechanical system 10 includes CMOS integrated circuits.

[0171] As mentioned above with respect to other embodiments of the present inventions, prior to formation, deposition and/or growth of insulation layer 32 and/or conductive layer 34, additional micromachined mechanical structures 12 and/or transistors of circuitry 16 may be formed and/or provided in third substrate 14c or in other substrates that may be fixed to first substrate 14a and/or second substrate 14b. In this regard, the exposed surface of third substrate 14c or another substrate disposed thereon may be a suitable base upon which integrated circuits (for example, CMOS transistors) and/or micromachined mechanical structures 12. Such integrated circuits and micromachined mechanical structures 12 may be fabricated using the inventive techniques described herein and/or well-known fabrication techniques and equipment. For the sake of brevity, those discussions, in connection with the embodiments of FIGS. 36 and 37A-I, will not be repeated.

[0172] In this embodiment, the portion of substrate **14b** in which micromachined mechanical structure **12** is formed includes a conductivity that is the same as the conductivity of the semiconductor of third substrate **14c**. In this embodiment, micromachined mechanical structure **12** includes an isolation trenches **42a** and **42b** as well as isolation regions **44a** and **44b**. The isolation trenches **42a** and **42b**, and isolation regions **44a** and **44b**, in combination, electrically isolate contact **20** (and, in particular, contact areas **26a** and **26b**) from contiguous portions of third substrate **14c**. In this exemplary embodiment, isolation region **44a** is aligned with cavity **24** and trench **28a**, and isolation trenches **42a** and **42b** are aligned with isolation regions **44b** and **44c**. In this way, contact **20** includes suitable contact isolation.

[0173] Briefly, with reference to FIGS. **39A-39D** and **39F**, an exemplary method of fabricating or forming micromachined mechanical structure **12** according to this embodiment of the present inventions may be substantially the same as with the previous embodiment. For the sake of brevity those discussions will not be repeated.

[0174] With reference to FIG. **39E**, in this embodiment, isolation regions **44a** and **44b** are deposited and/or implanted into portions of substrate **14b** in order to facilitate electrical isolation of contact **20** after second substrate **14b** is secured or fixed (via, for example, bonding). The isolation regions **44a** and **44b** may be any material or structure that insulates contact **20**, for example, an insulator material and/or an oppositely doped semiconductor region. In the illustrative example, isolation regions **44a** and **44b** are oppositely doped semiconductor region (relative to the conductivity of substrate **14c**).

[0175] With reference to FIG. **39F**, trenches **28a-c** may be formed to define moveable electrode **18** and contact area **26a**. The trenches may be formed using well-known deposition and lithographic techniques. Notably, all techniques for forming or fabricating trenches **28a-c**, whether now known or later developed, are intended to be within the scope of the present inventions.

[0176] Thereafter, third substrate **14c** may be secured to the exposed portion(s) of second substrate **14b**. (See, FIG. **39G**). The third substrate **14b** may be secured using, for example, well-known bonding techniques such as fusion bonding, anodic-like bonding and/or silicon direct bonding. In conjunction with securing third substrate **14c** to second substrate **14b**, the atmosphere (including its characteristics) in which moveable electrode **18** operates may also be defined. Notably, all techniques of defining the atmosphere, including the pressure thereof, during the process of securing third substrate **14c** to second substrate **14b**, whether now known or later developed, are intended to be within the scope of the present inventions.

[0177] Thereafter, isolation trenches **42a** and **42b** are formed in portions of third substrate **14c**. (See, FIG. **39H**). The isolation trenches **42a** and **42b** may be formed using well-known lithographic and etching techniques. In this exemplary embodiment, the isolation trenches are aligned with isolation regions **44a** and **44b** which are disposed in or on second substrate **14b**.

[0178] With reference to FIG. **39I**, isolation trenches **42a** and **42b** may include a material that insulates contact **20** (and contact areas **26a** and **26b**) from portions of third substrate **14c**. In the exemplary embodiment, an insulating material, for example, silicon dioxide or silicon nitride, is deposited and/or grown in isolation trenches **42a** and **42b**. Indeed, as

illustrated, material that forms insulation layer **32** may also be deposited in isolation trenches **42a** and **42b**. Notably, isolation trenches **42a** and **42b** may include any material that insulates contact **20** (and contact areas **26a** and **26b**) from portions of third substrate **14c**.

[0179] With reference to FIG. **39I-39K**, microelectromechanical system **10** may be completed by depositing, forming and/or growing insulation layer **32** and a contact opening may be etched to facilitate electrical contact/connection to contact area **26b**. The processing may be the same or similar to that described herein with any of the other embodiments. For the sake of brevity, those discussions will not be repeated.

[0180] Moreover, as mentioned above with respect to other embodiments of the present inventions, prior to formation, deposition and/or growth of insulation layer **32** and/or conductive layer **34**, additional micromachined mechanical structures **12** and/or transistors of circuitry **16** may be formed and/or provided in third substrate **14c** or in other substrates that may be fixed to first substrate **14a** and/or second substrate **14b**. In this regard, the exposed surface of third substrate **14c** or another substrate disposed thereon may be a suitable base upon which integrated circuits (for example, CMOS transistors) and/or micromachined mechanical structures **12**. Such integrated circuits and micromachined mechanical structures **12** may be fabricated using the inventive techniques described herein and/or well-known fabrication techniques and equipment. For the sake of brevity, those discussions, in connection with the embodiments of FIGS. **38** and **39A-K**, will not be repeated.

[0181] In another embodiment, with reference to FIG. **40**, after formation of cavity **18** in first substrate **14a**, intermediate layer **54** is deposited or grown before second substrate **14b** is secured to first substrate **14a**. In one embodiment, intermediate layer **54** may be a native oxide. In another embodiment, a thin insulating layer is deposited. In this way, first substrate **14a** is electrically isolated from second substrate **14b**. Thereafter, second substrate **14b** may be fixed to intermediate layer **54** using, for example, well-known bonding techniques such as fusion bonding and/or anodic-like bonding. Before or after securing second substrate **14b** to first substrate **14a**, second cavity **30** may be formed in second substrate **14b** using well-known lithographic and etching techniques. In one exemplary embodiment, second cavity **30** also includes a depth of about 1 μm . Thereafter, the thickness of second substrate **14b** may be adjusted to accommodate further processing. For example, second substrate **14b** may be grinded and polished (using, for example, well known chemical mechanical polishing ("CMP") techniques) to a thickness of between 10 μm -30 μm .

[0182] FIGS. **41A-41H** illustrate an exemplary process flow for fabricating microelectromechanical system **10** of FIG. **23**. For the sake of brevity, the exemplary process flow will not be discussed in detail; reference however, is made to the discussions above.

[0183] The embodiment including intermediate layer **54** may be employed in conjunction with any of the embodiments described herein. (See, for example, FIGS. **42A** and **42B**, **43A-43K**). For the sake of brevity, the exemplary process flow will not be discussed in detail; reference however, is made to the discussions above.

[0184] There are many inventions described and illustrated herein. While certain embodiments, features, materi-

als, configurations, attributes and advantages of the inventions have been described and illustrated, it should be understood that many other, as well as different and/or similar embodiments, features, materials, configurations, attributes, structures and advantages of the present inventions that are apparent from the description, illustration and claims (are possible by one skilled in the art after consideration and/or review of this disclosure). As such, the embodiments, features, materials, configurations, attributes, structures and advantages of the inventions described and illustrated herein are not exhaustive and it should be understood that such other, similar, as well as different, embodiments, features, materials, configurations, attributes, structures and advantages of the present inventions are within the scope of the present inventions.

[0185] Each of the aspects of the present inventions, and/or embodiments thereof, may be employed alone or in combination with one or more of such aspects and/or embodiments. (See, for example, FIGS. 42A and 42B, 43A-43K). For the sake of brevity, those permutations and combinations will not be discussed separately herein. As such, the present inventions are not limited to any single aspect or embodiment thereof nor to any combinations and/or permutations of such aspects and/or embodiments.

[0186] Notably, it may be advantageous to adjust the alignment and etch processes to enhance electrical isolation of portions of micromachined mechanical structure 12, for example, contact 20 (including contact areas 26a and 26b). For example, with reference to FIG. 44, trench 28a may be aligned to provide suitable or predetermined overlap of isolation region 44a and 44b as well as include suitable or predetermined over etch into isolation region 44a. Further, isolation region 44c may include dimensions such that when cavity 30 is formed, a portion of isolation region 44c is removed. (See, FIGS. 45C and 45D). Moreover, with reference to FIG. 46A, isolation trenches 42a and 42b may include suitable or predetermined over etch into isolation regions 44a and 44b. Indeed, isolation trench 28a may be substantially larger and/or have considerably different tolerances than trenches 28b and 28c given that the dimensions of the trench are insignificant relative to trenches 28b and 28c which may largely define the mechanical structure of the system 10. (See, FIG. 46B). Such processing techniques may be applied to any of the embodiments described and/or illustrated herein.

[0187] Further, the processing flows described and illustrated herein are exemplary. These flows, and the order thereof, may be modified. All process flows, and orders thereof, to provide microelectromechanical system 10 and/or micromachined mechanical structure 12, whether now known or later developed, are intended to fall within the scope of the present inventions. For example, there are many techniques to form moveable electrode 18 and contact 20 (and in particular contact area 26a). With reference to FIG. 47A-47D, in one embodiment, mask 56a may be deposited and patterned. Thereafter, cavity 30 may be formed (See, FIGS. 47A and 47B). Thereafter, mask 56b may be deposited and patterned in order to form and define moveable electrode 18 and contact area 26 (See, FIGS. 47C and 47D).

[0188] Alternatively, with reference to FIGS. 48A-48C, masks 56a and 56b may be deposited and patterned. After trenches 28a-28c are formed, mask 56b may be removed and cavity 30 may be formed.

[0189] Further, substrates 14 may be processed to a predetermined and/or suitable thickness before and/or after other processing during the fabrication of microelectromechanical system 10 and/or micromachined mechanical structure 12. For example, with reference to FIGS. 49A-49G, in one embodiment, first substrate 14a may be a relatively thick wafer which is grinded (and polished) after substrates 14b and 14c are secured to a corresponding substrate (for example, bonded) and processed to form, for example, micromachined mechanical structure 12. (Compare, for example, FIGS. 49A-G and 49H).

[0190] The processing flows described and illustrated with respect to substrate 14c may also be modified. For example, with reference to FIGS. 50A-50G, in one embodiment, substrate 14c may be a relatively thick wafer which is grinded (and polished) after secured to a corresponding substrate (for example, bonded). In this exemplary embodiment, substrate 14c is grinded and polished after being bonded to substrate 14b. (Compare, for example, FIGS. 50C and 50D) Thereafter, contact 20 may be formed. (See, for example, FIGS. 50E-50G).

[0191] Indeed, substrate 14a and 14c may be processed (for example, grinded and polished) after other processing. (See, for example, FIGS. 51A-51J). Notably, all processing flows with respect to substrates 14 are intended to fall within the scope of the present invention.

[0192] Further, as mentioned above, each of the aspects of the present inventions, and/or embodiments thereof, may be employed alone or in combination with one or more of such aspects and/or embodiments. For example, with reference to FIG. 52, microelectromechanical system 10 may include implant regions 58a and 58b in substrate 14c to facilitate electrical isolation of contact area 26b from other portions of substrate 14c. In this embodiment implant regions 58a and 58b may be any material or structure that insulates contact 20, for example, an oppositely doped semiconductor region. FIGS. 53A-53H illustrate an exemplary process flow for fabricating microelectromechanical system 10 of FIG. 52 wherein implant regions 58a and 58b are oppositely doped semiconductor regions.

[0193] Notably, implant regions 58a and 58b may be employed in any of the embodiments described and illustrated herein. For example, the implant regions 58a and 58b may be employed in conjunction with or in lieu of isolation trenches 42a and 42b.

[0194] In addition, as mentioned above, isolation regions 44a and 44b may be deposited and/or implanted into portions of substrate 14b in order to facilitate electrical isolation of contact 20 after third substrate 14c (or second substrate 14b where an SOI substrate 14a is employed (see, FIG. 11)) is secured or fixed (via, for example, bonding). The isolation regions 44a and 44b may be any material or structure that insulates contact 20, for example, an insulation material and/or an oppositely doped semiconductor region. FIGS. 55A-55K illustrate an exemplary process flow for fabricating microelectromechanical system 10 of FIG. 54 wherein isolation regions 44a and 44b are insulation material (for example, a silicon nitride or silicon dioxide) and an insulation material is disposed in isolation trenches 42a and 42b.

[0195] Further, as an alternative to counter-doping a region in substrate 14c to form contact area 26b, with reference to FIG. 56 and FIGS. 57A-57J, contact area 26b may be formed by providing a "window" in substrate 14c (for example, etching a portion of substrate 14c as illustrated

in FIG. 57H) and thereafter depositing a suitable material to provide electrical conductivity with the underlying contact area 26a. Notably, the material (for example, a doped polysilicon) which forms contact area 26b may be deposited by epitaxial deposition and thereafter planarized to provide a suitable surface for contact 20 formation. (See, for example, FIGS. 57H and 57I).

[0196] As mentioned above, all forms of bonding, whether now known or later developed, are intended to fall within the scope of the present invention. For example, bonding techniques such as fusion bonding, anodic-like bonding, silicon direct bonding, soldering (for example, eutectic soldering), thermo compression, thermo-sonic bonding, laser bonding and/or glass reflow bonding, and/or combinations thereof.

[0197] Notably, any of the embodiments described and illustrated herein may employ a bonding material and/or a bonding facilitator material (disposed between substrates, for example, the second and third substrates) to, for example, enhance the attachment of or the “seal” between the substrates (for example, between the first and second substrates 14a and 14b, and/or the second and third substrates 14b and 14c), address/compensate for planarity considerations between substrates to be bonded (for example, compensate for differences in planarity between bonded substrates), and/or to reduce and/or minimize differences in thermal expansion (that is materials having different coefficients of thermal expansion) of the substrates and materials therebetween (if any). Such materials may be, for example, solder, metals, frit, adhesives, BPSG, PSG, or SOG, or combinations thereof.

[0198] With reference to FIG. 58, in one exemplary embodiment, bonding material or bonding facilitator material 60 may be disposed between substrates 14b and 14c. Such a configuration may provide certain advantages. For example, in this exemplary embodiment, micromachined mechanical structure 12 (including moveable electrode 18 and contact 20) is formed in second substrate 14b and encapsulated via third substrate 14c. In this regard, micromachined mechanical structure 12 is formed in a portion of substrate 14b. Thereafter, substrate 14c is secured (for example, bonded) to exposed surface of substrate 14b to encapsulate micromachined mechanical structure 12. In this embodiment, bonding material or bonding facilitator material 60 (for example, having a thickness of about 1 μm) is disposed and patterned on second substrate 14b to provide cavity 30 when third substrate 14c is disposed thereon and bonded thereto. Notably, substrates 14a, 14b and 14c may include the same or different conductivities.

[0199] As mentioned above, bonding material or bonding facilitator material 60 may include, for example, solder, metals, frit, adhesives, BPSG, PSG, or SOG, or combinations thereof. It may be advantageous to employ BPSG, PSG, or SOG in order to electrically isolate contact 20 from portions of substrates 14b and/or 14c. Moreover, BPSG, PSG, or SOG is compatible with CMOS processing, in the event that microelectromechanical system 10 includes CMOS integrated circuits in one or more of substrates 14 thereof.

[0200] Notably, FIGS. 59A-59G and 59J-59L illustrate an exemplary process flow for fabricating microelectromechanical system 10 of FIG. 58. The process flow may employ a flow which is substantially similar to the process of FIGS. 35A-35L—with the exception that bonding material or bonding facilitator material 60 is employed (deposited

and patterned) in addition to or in lieu of insulative layer 48b of FIGS. 35E-35L. For the sake of brevity, the discussion will not be repeated here.

[0201] An alternative embodiment employing bonding material or bonding facilitator material 60, and technique for fabricating such embodiment, is illustrated in FIGS. 60 and 61A-61K, respectively. In this embodiment, bonding material and/or a bonding facilitator material 60 is provided prior to formation of resonator 18 and contact area 26a (via contact area trench 28a and moveable electrode trenches 28b and 28c). As mentioned above, all process flows, and orders thereof, to provide microelectromechanical system 10 and/or micromachined mechanical structure 12, whether now known or later developed, are intended to fall within the scope of the present inventions.

[0202] The embodiments employing bonding material or bonding facilitator material 60 may be implemented in any of the embodiments described herein. For example, transistors of a transistor region may be formed prior to securing third substrate 14c to second substrate 14b. (See, for example, FIGS. 7A and 7B). Indeed, all of the “back-end” processing, in addition to formation of the transistors of transistor region, may be completed prior to securing third substrate 14c to second substrate 14b. (See, for example, FIGS. 8A and 8B).

[0203] Moreover, any of the bonding material or bonding facilitator materials 60 (may include, for example, solder, metals, frit, adhesives, BPSG, PSG, or SOG, or combinations thereof) may be implemented between the first and second substrates 14a and 14b, and/or the second and third substrates 14b and 14c, and/or any other substrates that are bonded. All such permutations are intended to fall within the scope of the present inventions.

[0204] Further, with respect to any of the embodiments described herein, circuitry 16 may be integrated in or on substrate 14, disposed in a separate substrate, and/or in one or more substrates that are connected to substrate 14 (for example, in one or more of the encapsulation wafer(s)). (See, for example, FIGS. 62-64). In this regard, microelectromechanical device 10 may include micromachined mechanical structure 12 and circuitry 16 as a monolithic-like structure including mechanical structure 12 and circuitry 16 in one substrate.

[0205] The micromachined mechanical structure 12 and/or circuitry 16 may also reside on separate, discrete substrates. (See, for example, FIGS. 65 and 66A-66F). In this regard, in one embodiment, such separate discrete substrate may be bonded to or on substrate 14, before, during and/or after fabrication of micromachined mechanical structure 12 and/or circuitry 16. (See, for example FIGS. 5, 6A-6D, 7A-7C and 8A).

[0206] For example, as mentioned above, the electronics or electrical circuitry may be clock alignment circuitry, for example, one or more phase locked loops (PLLs), delay locked loops (DLLs), digital/frequency synthesizer (for example, a direct digital synthesizer (“DDS”), frequency synthesizer, fractional synthesizer and/or numerically controlled oscillator) and/or frequency locked loops (FLLs). In this regard, the output of mechanical structure 12 (for example, an microelectromechanical oscillator or microelectromechanical resonator) is employed as a reference input signal (i.e., the reference clock). The PLL, DLL, digital/frequency synthesizer and/or FLL may provide frequency multiplication (i.e., increase the frequency of the

output signal of the microelectromechanical oscillator). The PLL, DLL, digital/frequency synthesizer and/or FLL may also provide frequency division (i.e., decrease the frequency of the output signal of the microelectromechanical oscillator). Moreover, the PLL, DLL, digital/frequency synthesizer and/or FLL may also compensate using multiplication and/or division to adjust, correct, compensate and/or control the characteristics (for example, the frequency, phase and/or jitter) of the output signal of the microelectromechanical resonator.

[0207] The multiplication or division (and/or phase adjustments) by compensation circuitry **18** may be in fine or coarse increments. For example, compensation circuitry **18** may include an integer PLL, a fractional PLL and/or a fine-fractional-N PLL to precisely select, control and/or set the output signal of compensated microelectromechanical oscillator. In this regard, the output of microelectromechanical resonator may be provided to the input of the fractional-N PLL and/or the fine-fractional-N PLL (hereinafter collectively “fractional-N PLL”), which may be pre-set, pre-programmed and/or programmable to provide an output signal having a desired, selected and/or predetermined frequency and/or phase.

[0208] Notably, in one embodiment, the parameters, references (for example, frequency and/or phase), values and/or coefficients employed by the compensation circuitry in order to generate and/or provide an adjusted, corrected and/or controlled output having, for example, a desired, selected and/or predetermined frequency and/or phase (i.e., the function of the compensation circuitry), may be externally provided to the compensation circuitry either before or during operation of compensated microelectromechanical oscillator. In this regard, a user or external circuitry/devices/systems may provide information representative of the parameters, references, values and/or coefficients to set, change, enhance and/or optimize the performance of the compensation circuitry and/or compensated microelectromechanical oscillator.

[0209] Finally, it should be further noted that while the present inventions will be described in the context of microelectromechanical systems including micromechanical structures or elements, the present inventions are not limited in this regard. Rather, the inventions described herein are applicable to other electromechanical systems including, for example, nanoelectromechanical systems. Thus, the present inventions are pertinent, as mentioned above, to electromechanical systems, for example, gyroscopes, resonators, temperatures sensors, accelerometers and/or other transducers.

[0210] The term “depositing” and other forms (i.e., deposit, deposition and deposited) in the claims, means, among other things, depositing, creating, forming and/or growing a layer of material using, for example, a reactor (for example, an epitaxial, a sputtering or a CVD-based reactor (for example, APCVD, LPCVD, or PECVD)).

[0211] Further, in the claims, the term “contact” means a conductive region, partially or wholly disposed outside the chamber, for example, the contact area and/or contact via.

[0212] It should be further noted that the term “circuit” may mean, among other things, a single component or a multiplicity of components (whether in integrated circuit form or otherwise), which are active and/or passive, and which are coupled together to provide or perform a desired function. The term “circuitry” may mean, among other things, a circuit (whether integrated or otherwise), a group of

such circuits, one or more processors, one or more state machines, one or more processors implementing software, or a combination of one or more circuits (whether integrated or otherwise), one or more state machines, one or more processors, and/or one or more processors implementing software. The term “data” may mean, among other things, a current or voltage signal(s) whether in an analog or a digital form.

[0213] The embodiments of the inventions described herein may include one or more of the following advantages, among others:

[0214] embodiments presenting mechanically robust encapsulation;

[0215] embodiments presenting clean environment for micromachined mechanical structure **12** (and the electrodes thereof);

[0216] embodiments presenting relatively less expensive fabrication in comparison to conventional techniques;

[0217] embodiments presenting relatively smaller footprint in comparison to conventional techniques;

[0218] embodiments presenting one or more surfaces compatible with/for CMOS circuitry/integration;

[0219] embodiments presenting single crystal surfaces (where one or more substrates are single crystal);

[0220] embodiments presenting diffused contacts;

[0221] embodiments eliminating epitaxial depositions;

[0222] embodiments eliminating SOI substrates;

[0223] embodiments presenting improved CMOS compatibility;

[0224] embodiments providing enhanced atmosphere/environment control and characteristics (for example, improved vacuum and lower/no chlorine);

[0225] improved gap control for definition of micromachined mechanical structure;

[0226] embodiments eliminating timed release of moveable electrodes (for example, timed HF (vapor) etch);

[0227] embodiments eliminating oxide stress in substrates;

[0228] embodiments providing enhanced stiction characteristics (for example, less vertical stiction); and

[0229] embodiments eliminating vents in the resonator and the attendant shortcomings of thin film encapsulation.

[0230] The above embodiments of the present inventions are merely exemplary embodiments. They are not intended to be exhaustive or to limit the inventions to the precise forms, techniques, materials and/or configurations disclosed. Many modifications and variations are possible in light of the above teaching. It is to be understood that other embodiments may be utilized and operational changes may be made without departing from the scope of the present inventions. As such, the foregoing description of the exemplary embodiments of the inventions has been presented for the purposes of illustration and description. It is intended that the scope of the inventions not be limited to the description above.

What is claimed is:

1. A microelectromechanical device comprising:
 - a first substrate;
 - a chamber;

- a microelectromechanical structure, wherein the microelectromechanical structure is (i) formed from a portion of the first substrate and (ii) at least partially disposed in the chamber;
- a second substrate, bonded to the first substrate, wherein a surface of the second substrate forms a wall of the chamber; and
- a contact, wherein:
- a first portion of the contact is (i) formed from a portion of the first substrate and (ii) at least a portion thereof is disposed outside the chamber; and
 - a second portion of the contact is formed from a portion of the second substrate.
- 2.** The microelectromechanical device of claim **1** wherein the second substrate includes polycrystalline silicon, porous polycrystalline silicon, amorphous silicon, silicon carbide, silicon/germanium, germanium, or gallium arsenide.
- 3.** The microelectromechanical device of claim **2** wherein the first substrate includes polycrystalline silicon, porous polycrystalline silicon, amorphous silicon, silicon carbide, silicon/germanium, germanium, or gallium arsenide.
- 4.** The microelectromechanical device of claim **2** wherein:
- the first portion of the contact is a semiconductor material having a first conductivity;
 - the second substrate is a semiconductor material having a second conductivity; and
 - the second portion of the contact is a semiconductor material having the first conductivity.
- 5.** The microelectromechanical device of claim **4** wherein the second portion of the contact is a polycrystalline or monocrystalline silicon that is counterdoped to include the first conductivity.
- 6.** The microelectromechanical device of claim **1** further including a trench, disposed in the second substrate and around at least a portion of the second portion of the contact.
- 7.** The microelectromechanical device of claim **6** wherein the trench includes a first material disposed therein to electrically isolate the second portion of the contact from the second substrate.
- 8.** The microelectromechanical device of claim **6** wherein the first material is an insulation material.
- 9.** The microelectromechanical device of claim **1** wherein the first substrate is an semiconductor on insulator substrate.
- 10.** The microelectromechanical device of claim **1** wherein the first and second substrates are bonded using fusion bonding, anodic-like bonding, silicon direct bonding, soldering, thermo compression, thermo-sonic, laser bonding and/or glass reflow.
- 11.** A microelectromechanical device comprising:
- a first substrate;
 - a second substrate, wherein the second substrate is bonded to the first substrate;
 - a chamber;
 - a microelectromechanical structure, wherein the microelectromechanical structure is (i) formed from a portion of the second substrate and (ii) at least partially disposed in the chamber;
 - a third substrate, bonded to the second substrate, wherein a surface of the third substrate forms a wall of the chamber; and
 - a contact, wherein:
 - a first portion of the contact is (i) formed from a portion of the second substrate and (ii) at least a portion thereof is disposed outside the chamber; and
 - a second portion of the contact is formed from a portion of the third substrate.
- 12.** The microelectromechanical device of claim **11** wherein the second substrate includes polycrystalline silicon, porous polycrystalline silicon, amorphous silicon, silicon carbide, silicon/germanium, germanium, or gallium arsenide.
- 13.** The microelectromechanical device of claim **12** wherein the third substrate includes polycrystalline silicon, porous polycrystalline silicon, amorphous silicon, silicon carbide, silicon/germanium, germanium, or gallium arsenide.
- 14.** The microelectromechanical device of claim **12** wherein:
- the first portion of the contact is a semiconductor material having a first conductivity;
 - the third substrate is a semiconductor material having a second conductivity; and
 - the second portion of the contact is a semiconductor material having the first conductivity.
- 15.** The microelectromechanical device of claim **14** wherein the second portion of the contact is a polycrystalline or monocrystalline silicon that is counterdoped to include the first conductivity.
- 16.** The microelectromechanical device of claim **17** further including a trench, disposed in the third substrate and around at least a portion of the second portion of the contact.
- 17.** The microelectromechanical device of claim **16** wherein the trench includes a first material disposed therein to electrically isolate the second portion of the contact from the third substrate.
- 18.** The microelectromechanical device of claim **16** wherein the first material is an insulator material.
- 19.** The microelectromechanical device of claim **16** further including an isolation region disposed in the second substrate such that the trench is aligned with and juxtaposed to the isolation region.
- 20.** The microelectromechanical device of claim **19** wherein:
- the first portion of the contact is a semiconductor material having a first conductivity;
 - the isolation region is a semiconductor material having a second conductivity; and
 - the second portion of the contact is a semiconductor material having the first conductivity.
- 21.** The microelectromechanical device of claim **20** wherein the trench includes a first material disposed therein to electrically isolate the second portion of the contact from the second substrate.
- 22.** The microelectromechanical device of claim **16** wherein the first material is a semiconductor material having the second conductivity.
- 23.** The microelectromechanical device of claim **11** further including an isolation region, disposed in the first substrate such that the first portion of the contact is aligned with and juxtaposed to the isolation region.
- 24.** The microelectromechanical device of claim **11** further including:
- a first isolation region, disposed in the first substrate such that the first portion of the contact is aligned with and juxtaposed to the first isolation region; and
 - a second isolation region, disposed in the second substrate such that the second portion of the contact is aligned with and juxtaposed to the second isolation region.

25. The microelectromechanical device of claim **24** wherein:

the first and second portions of the contact are semiconductor materials having a first conductivity; and
the first and second isolation regions are semiconductor materials having the second conductivity.

26. The microelectromechanical device of claim **25** further including a trench, disposed in the third substrate and around at least a portion of the second portion of the contact.

27. The microelectromechanical device of claim **26** wherein the trench includes a first material disposed therein to electrically isolate the second portion of the contact from the third substrate.

28. The microelectromechanical device of claim **27** wherein the trench is aligned with and juxtaposed to the second isolation region.

29. The microelectromechanical device of claim **28** wherein the first material is an insulator material.

30. The microelectromechanical device of claim **11** wherein the second and third substrates are bonded using fusion bonding, anodic-like bonding, silicon direct bonding, soldering, thermo compression, thermo-sonic, laser bonding and/or glass reflow.

* * * * *