

(19) World Intellectual Property Organization
International Bureau



(43) International Publication Date
8 May 2003 (08.05.2003)

PCT

(10) International Publication Number
WO 03/037162 A2

- (51) International Patent Classification⁷: A61B
- (21) International Application Number: PCT/US02/34003
- (22) International Filing Date: 24 October 2002 (24.10.2002)
- (25) Filing Language: English
- (26) Publication Language: English
- (30) Priority Data:
10/032,378 26 October 2001 (26.10.2001) US
- (71) Applicant: ATRICURE INC. [US/US]; 6033 Schumacher Park Drive, West Chester, OH 45069 (US).

(81) Designated States (*national*): AE, AG, AL, AM, AT, AU, AZ, BA, BB, BG, BR, BY, BZ, CA, CH, CN, CO, CR, CU, CZ, DE, DK, DM, DZ, EC, EE, ES, FI, GB, GD, GE, GH, GM, HR, HU, ID, IL, IN, IS, JP, KE, KG, KP, KR, KZ, LC, LK, LR, LS, LT, LU, LV, MA, MD, MG, MK, MN, MW, MX, MZ, NO, NZ, OM, PH, PL, PT, RO, RU, SD, SE, SG, SI, SK, SL, TJ, TM, TN, TR, TT, TZ, UA, UG, UZ, VC, VN, YU, ZA, ZM, ZW.

(84) Designated States (*regional*): ARIPO patent (GH, GM, KE, LS, MW, MZ, SD, SL, SZ, TZ, UG, ZM, ZW), Eurasian patent (AM, AZ, BY, KG, KZ, MD, RU, TJ, TM), European patent (AT, BE, BG, CH, CY, CZ, DE, DK, EE, ES, FI, FR, GB, GR, IE, IT, LU, MC, NL, PT, SE, SK, TR), OAPI patent (BF, BJ, CF, CG, CI, CM, GA, GN, GQ, GW, ML, MR, NE, SN, TD, TG).

- (72) Inventors: HOOVEN, Michael, D.; 7778 Bennington Drive, Cincinnati, OH 44241 (US). GODINHO DE QUEIROZ E MELO, Joao; Av. Miguel Torga 21 4A, P-1070-183 Lisboa (PT).
- (74) Agents: MC FARRON, Gary, W. et al.; Cook, Alex, McFarron, Manzo, Cummings & Mehler, Lt, d., 200 West Adams Street, Suite 2850, Chicago, IL 60606 (US).

Published:
— without international search report and to be republished upon receipt of that report

For two-letter codes and other abbreviations, refer to the "Guidance Notes on Codes and Abbreviations" appearing at the beginning of each regular issue of the PCT Gazette.

(54) Title: TRANSMURAL ABLATION DEVICE WITH INTEGRAL EKG SENSOR

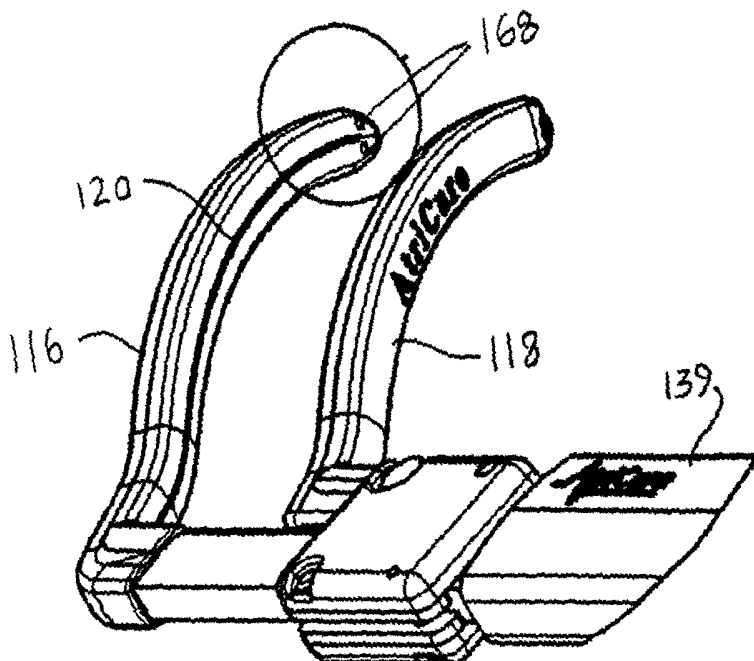

(57) Abstract: A method and apparatus for transmural ablation using an instrument containing two electrodes or cryogenic probes. A clamping force is exerted on the two electrodes or probes such that the tissue of the hollow organ is clamped therebetween. Bipolar RF energy is then applied between the two electrodes, or the probes are cryogenically cooled, thus ablating the tissue therebetween. A monitoring device measures a suitable parameter, such as impedance or temperature, and indicates when the tissue between the electrodes has been fully ablated.



WO 03/037162 A2

TRANSMURAL ABLATION DEVICE WITH INTEGRAL EKG SENSOR

CROSS REFERENCE TO RELATED APPLICATION

[0001] This application is a continuation-in-part of application Serial No. 09/844,225 filed April 27, 2001, which is a continuation in part of application Serial No. 09/747,609 December 22, 2000, which claims the benefit of provisional application Serial No. 60/200,072, filed April 27, 2000.

BACKGROUND OF THE INVENTION

[0002] Atrial fibrillation is the most common heart arrhythmia in the world, affecting over 2.5 million people in the United States alone. Ablation of cardiac tissue, in order to create scar tissue that poses an interruption in the path of the errant electrical impulses in the heart tissue, is a commonly performed procedure to treat cardiac arrhythmias. Such ablation may range from the ablation of a small area of heart tissue to a series of ablations forming a strategic placement of incisions in both atria to stop the conduction and formation of errant impulses.

[0003] Ablation has been achieved or suggested using a variety of techniques, such as freezing via cryogenic probe, heating via RF energy, surgical cutting and other techniques. As used here, "ablation" means the removal or destruction of the function of a body part, such as cardiac tissue, regardless of the apparatus or process used to carry out the ablation. Also, as used herein; "transmural" means through the wall or thickness, such as through the wall or thickness of a hollow organ or vessel.

[0004] Ablation of cardiac tissue may be carried out in an open surgical procedure, where the breastbone is divided and the surgeon has direct access to the heart, or through a minimally invasive route, such as between the ribs or via catheter that is introduced through a vein, and into the heart.

-2-

[0005] Prior to any ablation, the heart typically is electronically mapped to locate the point or points of tissue which are causing the arrhythmia. With minimally invasive procedures such as via a catheter, the catheter is directed to the aberrant tissue, and an electrode or cryogenic probe is placed in contact with the endocardial tissue. RF energy is delivered from the electrode to the tissue to heat and ablate the tissue (or the tissue may be frozen by the cryogenic probe), thus eliminating the source of the arrhythmia.

[0006] Common problems encountered in this procedure are difficulty in precisely locating the aberrant tissue, and complications related to the ablation of the tissue. Locating the area of tissue causing the arrhythmia often involves several hours of electrically "mapping" the inner surface of the heart using a variety of mapping catheters, and once the aberrant tissue is located, it is often difficult to position the catheter and the associated electrode or probe so that it is in contact with the desired tissue.

[0007] The application of either RF energy or ultra-low temperature freezing to the inside of the heart chamber also carries several risks and difficulties. It is very difficult to determine how much of the catheter electrode or cryogenic probe surface is in contact with the tissue since catheter electrodes and probes are cylindrical and the heart tissue cannot be visualized clearly with existing fluoroscopic technology. Further, because of the cylindrical shape, some of the exposed electrode or probe area will almost always be in contact with blood circulating in the heart, giving rise to a risk of clot formation.

[0008] Clot formation is almost always associated with RF energy or cryogenic delivery inside the heart because it is difficult to prevent the blood from being exposed to the electrode or probe surface. Some of the RF current flows through the blood between the electrode and the heart tissue

and this blood is coagulated, or frozen when a cryogenic probe is used, possibly resulting in clot formation. When RF energy is applied, the temperature of the electrode is typically monitored so as to not exceed a preset level, but temperatures necessary to achieve tissue ablation almost always result in blood coagulum forming on the electrode.

[0009] Overheating or overcooling of tissue is also a major complication, because the temperature monitoring only gives the temperature of the electrode or probe, which is, respectively, being cooled or warmed on the outside by blood flow. The actual temperature of the tissue being ablated by the electrode or probe is usually considerably higher or lower than the electrode or probe temperature, and this can result in overheating, or even charring, of the tissue in the case of an RF electrode, or freezing of too much tissue by a cryogenic probe. Overheated or charred tissue can act as a locus for thrombus and clot formation, and over freezing can destroy more tissue than necessary.

[00010] It is also very difficult to achieve ablation of tissue deep within the heart wall. A recent study reported that to achieve a depth of ablation of 5mm, it was necessary to ablate an area almost 8mm wide in the endocardium. See, "Mechanism, Localization, and Cure of Atrial Arrhythmias Occurring After a New Intraoperative Endocardial Radiofrequency Ablation Procedure for Atrial Fibrillation," Thomas, et al., J. Am. Coll. Cardiology, Vol. 35, No. 2, 2000. As the depth of penetration increases, the time, power, and temperature requirements increase, thus increasing the risk of thrombus formation.

[00011] In certain applications, it is desired to obtain a continuous line of ablated tissue in the endocardium. Using a discrete or point electrode or probe, the catheter must be "dragged" from point to point to create a line, and frequently the line is not continuous. Multielectrode catheters have been developed which can be left in place, but continuity can still be difficult to achieve, and the

lesions created can be quite wide.

[00012] Because of the risks of char and thrombus formation, RF energy, or any form of endocardial ablation, is rarely used on the left side of the heart, where a clot could cause a serious problem (e.g., stroke). Because of the physiology of the heart, it is also difficult to access certain areas of the left atrium via an endocardial, catheter-based approach.

[00013] Recently, epicardial ablation devices have been developed which apply RF energy to the outer wall of the heart to ablate tissue. These devices do not have the same risks concerning thrombus formation. However, it is still difficult to create long, continuous lesions, and it is difficult to achieve good depth of penetration without creating a large area of ablated tissue.

[00014] As noted above, other forms of energy have been used in ablation procedures, including ultrasound, cryogenic ablation, and microwave technology. When used from an endocardial approach, the limitations of all energy-based ablation technologies to date are the difficulty in achieving continuous transmural lesions, and minimizing unnecessary damage to endocardial tissue. Ultrasonic and RF energy endocardial balloon technology has been developed to create circumferential lesions around the individual pulmonary veins. See e.g., U.S. Pat. No. 6,024,740 to Lesh et al. and U.S. Pat. Nos. 5,938,660 and 5,814,028 to Swartz et al. However, this technology creates rather wide (greater than 5mm) lesions which could lead to stenosis (narrowing) of the pulmonary veins. See, "Pulmonary Vein Stenosis after Catheter Ablation of Atrial Fibrillation," Robbins, et al., Circulation, Vol. 98, pages 1769-1775, 1998. The large lesion area can also act as a locus point for thrombus formation. Additionally, there is no feedback to determine when full transmural ablation has been achieved. Cryogenic ablation has been attempted both endocardially and epicardially (see e.g., U.S. Pat. Nos.

5,733,280 to Avitall, 5,147,355 to Friedman et al., and 5,423,807 to Milder, and WO 98/17187, the latter disclosing an angled cryogenic probe, one arm of which is inserted into the interior of the heart through an opening in the heart wall that is hemostatically sealed around the arm by means of a suture or staples), but because of the time required to freeze tissue, and the delivery systems used, it is difficult to create a continuous line, and uniform transmuralty is difficult to verify.

[00015] Published PCT applications W0 99/56644 and W0 99/56648 disclose an endocardial ablation catheter with a reference plate located on the epicardium to act as an indifferent electrode or backplate that is maintained at the reference level of the generator. Current flows either between the electrodes located on the catheter, or between the electrodes and the reference plate. It is important to note that this reference plate is essentially a monopolar reference pad. Consequently, there is no energy delivered at the backplate/tissue interface intended to ablate tissue. Instead, the energy is delivered at the electrode/tissue interface within the endocardium, and travels through the heart tissue either to another endocardial electrode, or to the backplate. Tissue ablation proceeds from the electrodes in contact with the endocardium outward to the epicardium. Other references disclose epicardial multielectrode devices that deliver either monopolar or bipolar energy to the outside surface of the heart.

[00016] It is important to note that all endocardial ablation devices that attempt to ablate tissue through the full thickness of the cardiac wall have a risk associated with damaging structures within or on the outer surface of the cardiac wall. As an example, if a catheter is delivering energy from the inside of the atrium to the outside, and a coronary artery, the esophagus, or other critical structure is in contact with the atrial wall, the structure can be damaged by the transfer of energy from

within the heart to the structure. The coronary arteries, esophagus, aorta, pulmonary veins, and pulmonary artery are all structures that are in contact with the outer wall of the atrium, and could be damaged by energy transmitted through the atrial wall.

[00017] Accordingly, it is the object of the present invention to provide an improved method and device for making transmural ablations to heart tissue.

[00018] It is a related object to provide a method and device for making transmural ablation in heart tissue that minimizes unnecessary damage to the heart tissue.

[00019] It is a further object to provide a method and device for making transmural ablation in heart tissue that creates continuous lesions in a single step.

[00020] It is still a further object to provide a method and device for monitoring the electrical conductivity of the tissue in the transmural lesion simultaneously with the creation of the lesion.

[00021] It is also an object to provide a method and device for measuring the temperature of the tissue forming the lesion simultaneously with its creation.

SUMMARY OF THE INVENTION

[00022] These objects, and others which will become apparent upon reference to the following detailed description and attached drawings, are achieved by the use of a clamping and ablating device for use in treating cardiac arrhythmia having first and second handle members, with first and second mating parallel jaw members associated with the first and second handle members, respectively. The jaw members are preferably curved and are movable by the handle members between a first open position and a second clamped position, and the jaw members have insulated outer surfaces which may have convex, opposed mating surfaces. Each mating surface has a central region, with the central region of the first jaw being aligned with the central region of the second jaw. A first elongated electrode

-7-

extends along the central region of the first jaw and a second elongated electrode extends along the central region of the second jaw. The first and second electrodes are adapted to be connected to an RF energy source so that, when activated, the electrodes are of opposite polarity. In a preferred embodiment, the electrodes are made of gold-plated copper and measure between approximately 3 to 8 cm in length and approximately 0.12 to 0.6 mm in width. By the use of such a device a clamping zone is created that is approximately at least three times wider than the contact zone of the electrodes with the tissue. This permits the ablation to be performed with a minimum of contact between the electrodes and any blood cells, thus greatly reducing the likelihood of thrombus. The design also allows for a minimum distance between the electrodes, further encouraging complete, transmural ablation that creates a continuous lesion in a single step.

BRIEF DESCRIPTION OF THE DRAWINGS

[00023] Figure 1 is a schematic view showing a procedure in accordance with the present invention utilizing ablation elements operatively connected to either a source of RF energy or cryogenic fluid.

[00024] Figure 2 is a cross-section of an ablation element for use in the present invention taken along lines 2-2 of Figure 1.

[00025] Figures 3-6 show alternate configurations for the ablation elements of Figure 2.

[00026] Figure 7 shows a further step in the inventive procedure in which tissue is clamped between the ablation elements.

[00027] Figures 8-12 schematically illustrate the inventive procedure so as to make a transmural lesion that fully circumscribes a pulmonary vein, with Figure 9 showing a cross-sectional view of the clamp/ablation element in contact with the atrial tissue to express blood from the clamped area.

[00028] Figures 13-17 show a further method according to the present invention in which transmural lesions are made so as to circumscribe both pulmonary veins.

[00029] Figures 18-22 show a further procedure in which a transmural lesion is made so as to circumscribe a single pulmonary vein.

[00030] Figures 23-27 illustrate a further procedure in which a transmural lesion is made so as to circumscribe both pulmonary veins.

[00031] Figure 28 is a perspective view of a further embodiment of a grasper for use in an open chest procedure in accordance with the present invention showing the grasper in its "closed" position.

[00032] Figure 29 is a perspective view of the grasper of Figure 28 with the grasper in its "open" position.

[00033] Figure 30 is an enlarged perspective view of the working position of the grasper of Figure 28 with the grasper jaws in the "closed" position.

[00034] Figure 31 is an enlarged perspective view of the working portion of the grasper of Figure 28 with the grasper jaws in the "open" position.

[00035] Figure 32 is an enlarged cross-sectional view of the grasper jaws for the grasper of Figure 28.

[00036] Figure 33 is a perspective view of a further embodiment of a grasper, which may be used in either an open or a minimally invasive procedure, along with its associated electro-surgical generator.

[00037] Figure 34 is a side view of the grasper of Figure 33 showing the grasper in its "open" position.

[00038] Figure 35 is an exploded perspective view of the grasper of Figure 33.

[00039] Figure 36 is a side cross-sectional view of the grasper of Figure 33 with the grasper jaws in the "open" position.

[00040] Figure 37 is a side cross-sectional view of the grasper of Figure 33 with the grasper jaws in the "closed"

position.

[00041] Figure 38 is a cross-sectional view taken along line 38-38 of Figure 34 showing the grasper jaws in the "open" position.

[00042] Figure 39 is a cross-sectional view of the grasper jaws taken along the line 39-39 of Figure 37 showing the grasper jaws in the "closed" position.

[00043] Figure 40 is a cross-sectional view of the graspers taken along line 40-40 of Figure 34.

[00044] Figures 41-51 show alternate constructions for the electrodes suitable for use in the present invention, with Figures 41 and 43-51 being cross-sectional views similar to Figures 38 and 39, and Figure 42 being a cross-sectional view taken along line 42-42 of Figure 41.

[00045] Figures 52A-K illustrate eleven different ablations to the left and right atrium (as seen from behind in Figure 52A) and the methods for making the lesions (Figures 52B-K).

[00046] Figure 53A is a perspective view of a further embodiment of device for performing transmural ablation according to the present invention.

[00047] Figure 53B is a perspective view of the transmural ablation device of Figure 53A with a portion removed to show detail.

[00048] Figure 54 is an exploded perspective view of the transmural ablation device of Figure 52.

[00049] Figure 55 is a longitudinal cross-sectional view of an obturator tip electrode for use in the device of Figure 52.

[00050] Figure 56 is a piercing tip electrode for use in the device of Figure 52.

[00051] Figure 57 is an enlarged side view of the tip of the instrument shown in Figure 52.

[00052] Figures 58A-58G illustrate the use of the instrument of Figure 52 to form a transmural ablation.

[00053] Figure 59 shows a series of transmural ablations

contemplated by the MAZE procedure.

[00054] Figures 60A-60I illustrate a procedure for performing a circumferential lesion in lumen such as a pulmonary vein.

[00055] Figure 61A-61J show the use of the instrument of Figure 52 for forming a continuous transmural ablation around a pair of pulmonary veins.

[00056] Figure 62A-I show a further device for performing transmural ablations and the method for making such ablations.

[00057] Figure 63 is a perspective view of a further embodiment of a grasper adapted for use in minimally invasive procedures.

[00058] Figure 64 is an enlarged plan view of the handle position of the grasper of Figure 63, with portions removed to show detail.

[00059] Figures 65A and 65B are enlarged plan views of the jaw actuation mechanism for the grasper of Figure 63.

[00060] Figure 66 is an enlarged fragmentary perspective view of the jaws of grasper of Figures 33-40.

[00061] Figure 67 is an enlarged perspective view of the tip of the fixed jaw shown in Figure 66.

DETAILED DESCRIPTION OF THE PREFERRED EMBODIMENTS

[00062] With reference to the present invention, the compression of the atrial tissue is important because it insures that the exposed electrode surface or cryogenic probe is not in contact with any tissue or blood except the clamped tissue to be ablated. Specifically, the clamping of the tissue between the electrodes or cryogenic probes insures that the conductive or cooled area is only in contact with the clamped tissue. The compressed tissue acts to isolate the electrically active or cryogenically cooled surface, and prevents inadvertent energy delivery to other parts of the heart or blood. The outside temperature of the electrode can easily be monitored to insure that the temperature of the insulation in contact with blood remains

-11-

below a critical temperature (40°C, for example).

[00063] In one form of the invention, transmural ablation using RF energy is accomplished by providing an atrial ablation device having a lower "j" clamp/electrode element and placing it on the atrial tissue below the pulmonary veins.

[00064] Once the pulmonary veins have been isolated, an upper clamp/electrode element is introduced, and the clamp assembly "J" is worked back onto the epicardial atrial tissue. Once the jaws are positioned below the ostia of the pulmonary veins, the tissue is partially clamped, allowing continued flow from the pulmonary veins to the left atrium. Once the clamps are safely away from the pulmonary vein tissue, and onto atrial tissue, the clamps are closed together to compress the tissue. Once the tissue is compressed, bipolar RF energy is used to ablate the clamped atrial tissue. The clamps are then removed, the lesion having been created. Lesions may also be created by inserting one clamp/electrode element through an incision in the heart so as to permit contact with endocardial tissue. This incision may be created with a separate instrument. Alternatively, the tip of one of the jaws may have a piercing structure associated therewith for making the entry incision. Once the clamps are properly located, the tissue is compressed and RF energy is applied.

[00065] Turning now to the figures of the drawings, a method embodying the present invention is shown schematically in Figure 1. A clamping type device 10 is provided to group the two walls 22, 24 of the atrium 20, and delivers bipolar RF energy through both walls held between the two upper and lower clamp jaws 50, 51. Figure 1 shows the upper and lower parallel clamp jaws 50, 51 and electrodes 52, 53 positioned above and below atrial tissue 22, 24, distal to the pulmonary veins. Figure 2, Section 2-2 of Figure 1, shows a cross-section of the clamping member including the insulator 28 and electrode 53. Alternate

-12-

configurations of the clamping members are shown in Figures 3-6. Figure 3 shows a cross section of the electrode consisting of an insulating layer 11, and a conductive strip 12. The electrode of Figure 3 may be constructed of a tungsten wire as the conductive material 12, with polyamide as the insulating material 11. The conductive strip is created by exposing a part of the tungsten wire through the polyamide. Figures 4 and 5 show an alternate electrode construction consisting of a carbon fiber element 13, and an insulating material 14, such as ABS. The conductive strip 15 may be comprised of a copper/gold electrode plated onto the ABS. Figure 6 shows a cross section of yet another possible electrode design where the conductive material 16 consists of a stainless steel needle with lumen 17 and insulating material 18.

[00066] Figure 7 shows the parallel jaws 50, 51 clamping and ablating the atrial tissue 20 distal to the pulmonary veins 26. Proximal point A is clamping and ablating the atrial tissue distal to the pulmonary veins. Proximal point A is the most proximal point of ablated tissue on both the upper and lower atrial wall. Distal point B is the most distal point of ablated tissue on both the upper and lower atrial wall.

[00067] Figures 8-12 show the inventive procedure that fully circumscribes a pulmonary vein with transmural lesions. Figure 8 shows a top view of the instrument jaws positioned for a 2-step isolation of a single pulmonary vein. The lower jaw is directly beneath the upper jaw, and is not shown. Proximal point A and distal point B correspond to Figure 7.

[00068] Figure 9 shows a cross-sectional view of the jaws clamping and ablating atrial tissue. Importantly, Figure 9 shows that the electrode/clamp configuration provides a clamped zone of tissue that is wider than the zone of ablated tissue. This is achieved by using an electrode width that is narrower than the clamped tissue width, and

preferably less than one-third of the clamped tissue width. As shown in Figure 9 (and better illustrated in Figure 26), the electrode forms the apex of the triangular clamping member. Other convex shapes are also contemplated.

[00069] The wider zone of clamped tissue serves several purposes. When the clamping members are closed onto tissue, any blood in the clamped zone is squeezed or expressed out. Further, the distance between the electrodes is minimized, so that the ablation zone remains narrow. It is important to isolate the blood from the ablation zone to avoid creating thrombus. Accordingly, a clamped zone that isolates the ablation zone from the blood minimizes the temperature at the periphery of the ablation zone and will reduce the likelihood of the formation of thrombus by the blood in contact with the clamped zone.

[00070] Once tissue has been fully ablated with the clamp in the position shown in Figure 8, an ablation line of tissue on both upper and lower atrial walls is created. This is shown as ablation line 60 in Figure 10. The clamp is then repositioned to the position shown in Figure 10, so that the distal point D overlaps the ablation line 60. The tissue is clamped and ablated as shown in Figures 7 and 9, and a second ablation line 61 (Fig. 11) is formed on both the upper and lower atrial walls. Proximal point C and distal point D correspond to points A and B respectively. The full ablation line is shown in Figures 11 and 12 with points A-D as shown.

[00071] This "clamping" method and device for creating transmural lesions has a number of advantages. First, using a two step method as shown allows for clamping and ablation of atrial tissue without stopping the blood flow from the pulmonary vein. Secondly, by clamping both walls together, and delivering energy through the clamped tissue, the atrial tissue is not penetrated. Because the atrial tissue is not penetrated, a larger jaw can be used, and the clamping force can be much higher because of the increased stiffness of the

jaw. Also, there is no concern of bleeding from an atrial puncture.

[00072] Another advantage of this method and device is that ablation of tissue within the pulmonary veins is avoided, as recent articles have shown that ablation of tissue within the pulmonary veins can cause pulmonary hypertension and stenosis. Specifically referring to Figures 13-17, a longer jaw could be used to create an ablation line through atrial tissue which electrically isolates both pulmonary veins using the same method.

[00073] Figures 18-22 show the clamping device in a curved-jaw embodiment that creates a circumferential lesion around the pulmonary vein in one step. Figures 18 and 19 show the clamp jaws positioned around the pulmonary vein. Figures 20 and 21 show the device clamping and ablating atrial tissue distal to the pulmonary vein. Figure 22 shows the resulting ablation line 60.

[00074] Figures 23-27 show the same concept applied to a device and method for creating a lesion around both pulmonary veins. The advantage of this concept is that the entire lesion is created in one step. The disadvantage is that blood flow from the pulmonary vein(s) is cut off during ablation. Using a curved electrode also allows the user to ablate tissue more distal to the pulmonary vein than would be possible with a straight electrode. Note that this curved type electrode could be used with a two step procedure as described above, using "left" and "right" curved devices to create a lesion which was more distal to the pulmonary veins. Note also that this method and device are not limited to use around the pulmonary veins, but could be used anywhere in the atrium that the clamp could be applied.

[00075] Turning to Figures 28-32, there is seen a further version of a cardiac grasper 70 suitable for an open chest procedure in accordance with the present invention. The grasper 70 includes two ring handles 72, 74 joined together

for relative movement by a pivot screw or pin 76. Each handle 72, 74 has a jaw member 78, 80 respectively associated therewith, each jaw being curved so that it has a major portion that is substantially perpendicular to the handles. This gives the grasper 70 an L-shaped appearance, with a working portion of the jaws being between approximately 3-8 cm in length.

[00076] The grasper is made of a rigid material, such as stainless steel, and is substantially encased in a durable insulating material, such as ABS plastic. With reference to Figure 32, which shows the opposed jaw members in cross section, the stainless steel structural support is designated 82. The structural support 82 is completely encased by insulating members 84, 86 and 88. The tips 78a, 80a of the jaws may be made of a soft, atraumatic material in order to reduce the likelihood of unintentional injury of tissue by the jaws.

[00077] In keeping with the invention, the grasper jaws have raised or convex, opposed tissue clamping surfaces, 90, 92, respectively, with each clamping surface, 90, 92 centrally supporting an electrode 94, 96, respectively, of opposite polarity. RF energy of opposite polarity is supplied to the electrodes 94, 96 through conductors 98, 100, which are connected to an RF generator. As with the previously-described jaw members, this electrode/clamp configuration provides a clamped zone of tissue that is significantly wider than the zone of ablated tissue created by the opposed electrodes. This causes for any blood in the clamp zone to be squeezed or expressed out of the ablation zone, thus reducing the likelihood of thrombus formation, as well as minimizing the distance between the electrodes, so that the ablation zone remains narrow. The clamping also eliminates the cooling effect of circulating blood.

[00078] With reference to Figure 32, the electrodes 94, 96 have a T-shaped cross section, with the cross portion of the T resting on the insulating member 88 and the upright

portion of the T protruding through a narrow opening in the insulating member 84, thus creating an exposed electrode surface that contacts the tissue grasped between the jaws. In practice, the electrodes are preferably made of gold-plated copper and extend along substantially the entire working surface of the jaw members. The exposed portions of the electrode are generally less than 1.25mm in width, and preferably between approximately 0.12-0.6 mm in width. This insures that most of the jaw surface is insulator, and that the electrode comprises generally less than one-third of the width of the jaw.

[00079] In keeping with a further aspect of the invention, the graspers may provide feedback that permits the user to gauge the completeness (i.e., degree of transmural) of the ablation. Specifically, a transmural lesion blocks electrical signals because it is non-conductive scar tissue. Because impedance is simply the inverse of conductivity, the ability of the lesion to block electrical signals is accurately indicated by its impedance, which can be measured simultaneously with the creation of the lesion. During RF energy application to the tissue to be ablated, the current and voltage applied to the tissue are measured, and the impedance calculated and stored. Based upon a function of the impedance (e.g., its value, the change in value, or the rate of change in value)) it is determined whether ablation is complete and transmural. See e.g., U.S. Patent No. 5,403,312, which is incorporated by reference herein. Indicator lights or other types of signals (e.g., audible may be associated with the grasper to correspond to the degree of ablation determined by the impedance feedback system. For example, once the impedance reaches a certain level for a certain period of time, a red light may be activated to signal that ablation is complete.

[00080] In keeping with another aspect of the invention, a feedback system for determining the temperature of the ablated tissue is also provided. To this end, the jaws

-17-

include a series of thermocouples 102 that are supported in the insulating member 84 remote from the associated electrode 94 near the edge of the jaw 78. The thermocouples 102 protrude slightly through the surface of the insulating member 84 so as to engage any tissue clamped between the jaws 72, 74. Wires 104 are attached to the thermocouples 102 to transmit the information received to a remote location. Again, a visual or other indicator may be provided to alert the user that a certain pre-determined critical temperature (e.g., 40°C) has been reached, thus permitting the user to avoid undesired thermal spread.

[00081] Turning to Figures 33-37, there is a further version of a cardiac grasper 110 suitable for both open and minimally-invasive procedures in accordance with the present invention. As seen in Figure 33, the grasper 110 includes a cord 112 for housing the conductors (not shown) and for plugging into an electrosurgical generator 114 to provide current to the grasper 110. As discussed above, the generator 114 includes a display 115 to provide a simultaneous visual indication of the degree of conductance of the tissue being ablated. The instrument 110 includes opposed parallel, curved jaw assemblies 116, 118 with jaw assembly 116 being fixed and jaw assembly 118 being movable between an open position (as seen in Figures 34 and 36) to a closed position (shown in Figure 37). The fixed jaw assembly 116 comprises a fixed electrode 120, a fixed insulator 122 and a fixed jaw cap 124. The fixed electrode 120 provides an electrical pathway adjacent to the tissue to be ablated and is located on the inside of the fixed jaw assembly 116 (the "inside" being defined as the side that contacts the tissue to be ablated). The fixed insulator 122 surrounds the fixed electrode 120 and forms the inside of the fixed jaw assembly 116. The fixed jaw cap 124 forms the backside of the fixed jaw assembly 116 (the "backside" being defined as the surface opposite the fixed electrode 120).

[00082] The drive jaw assembly 118 comprises a drive

electrode 126, a drive insulator 128, and a drive jaw cap 130. The drive electrode 126 provides a second electrical pathway adjacent the tissue to be ablated and is located on the inside of the drive jaw assembly 118 ("inside" being defined as the side contacting the tissue to be ablated). The drive insulator 128 surrounds the drive electrode 126 and forms the inside of the drive jaw assembly 118. The drive jaw cap 130 forms the backside of the drive jaw assembly 118 ("backside" being defined as the surface opposite the drive electrode 126).

[00083] Each of the electrodes 120, 126 is attached to an electrically conductive means, such as a wire, that runs the length of the extension shaft and through the conductor cord 112 for coupling to the RF generator 114.

[00084] Each jaw assembly 116, 118 is supported by a two piece extension shaft comprising a right fixed member 132 and left fixed member 134 (for the fixed jaw) and a right drive member 136 and left drive member 138 (for the drive jaw 118). A shaft cap 139 covers the coextensive portions of the fixed members 132, 134 and the drive members 136, 138 (when the jaws are in the open position as seen in Figure 34). The right fixed member 132 and left fixed member 134 combine to form a structure that extends from a handle 140, through the shaft cap 139, and then terminating at the distal end of the instrument 110 in the fixed jaw assembly 116 on the right and left sides, respectively, of the instrument. Similarly, the right drive member 136 and left drive member 138 extend from the handle 140, through the shaft cap 139, and then terminate in the drive jaw assembly 118 on the right and left sides, respectively, of the instrument. The portions of the fixed members 132, 134 co-extensive with the fixed jaw assembly 116 are joined by a fixed bridge 142 along the length of the jaw. Similarly, the portions of the drive members 136, 138 co-extensive with the drive jaw assembly 118 are joined together by a drive bridge 144 along the length the drive jaw 118.

-19-

[00085] The handle 140 comprises two mating halves 140a, 140b for encapsulating the actuation and force control mechanisms for the grasper, as well as providing for grounding of the shaft components by means of a conductive shaft pin 141. In order to move the drive jaw assembly 118 between its open and closed positions, the handle 140 includes a lever comprising a pair of lever plates 146 and a lever shroud 148. The lever is pivotally mounted on a support member 150 extending between the two halves 140a, 140b of the handle 140, with a lever spring 151 biasing the lever to its open position (Figure 34). The lever plates 146 are coupled by a lever pin 152 to a carriage 154 that captures the proximal ends of the drive members 136, 138, so as to provide translational motion to these members.

[00086] The carriage 154 includes a lost motion assembly comprising a carriage spring 156 for controlling the minimum and maximum loads that can be applied to tissues that are to be captured between the jaw assemblies 116, 118. As can be readily appreciated, the thicker the tissue that is grasped between the jaws, the greater the compression of the spring 156, and the greater the compression force exerted by the jaws on the tissue. (The range of tissue thickness is expected to be between about 1-15mm.) Adjustment of the compression force is accomplished by pre-loading the carriage spring 156 with a load adjustment screw 158. The lost motion assembly also includes a thumb latch 160 for releasing the clamping pressure and for providing a mechanical stop for the spring-loaded carriage 154. The thumb latch 160 is pivotally mounted on a latch pin 162 to secure the thumb latch to the handle 140. Additionally, a latch spring 164 is provided for biasing the thumb latch 160 to its locked position. A latching step on the carriage 154 interfaces with the tip of the thumb latch 160 to provide for the mechanical stop.

[00087] When the lever is pivoted with respect to the handle 140, the drive jaw assembly 118 and its drive members

136, 138 slide along the longitudinal direction of the shaft to bring the two jaw assemblies 116, 118 into contact with the tissue intended to be grasped.

[00088] In order to ablate a narrow, long region of biological tissue with the instrument 110, the tissue is first placed between the open instrument jaws 116, 118. The user then grasps the actuation lever comprising the lever plates 146 and lever shroud 148 to apply the force required to drive the drive members 136, 138 and drive jaw assembly 118 distally, thus compressing the tissue and automatically engaging the thumb latch 160. The thumb latch 160 locks the position of the drive members 136, 138 and the drive jaw assembly 118 with respect to the handle 140 and the fixed jaw assembly 116. The amount of jaw force on the tissue is controlled by the lost motion assembly between the lever and the drive members 136, 138.

[00089] With the jaws closed on the tissue, the operator activates the RF generator 114. RF energy passes through the tissue between the electrodes 120, 126, thus ablating the tissue between these electrodes. After completion of the ablation cycle, the operator releases the clamping of the tissue by depressing the thumb latch 160, thus releasing the carriage 154. With the carriage 154 released, the lever spring 151 drives the drive members 136, 138 and the drive jaw assembly 118 proximally to their open positions. The actuation lever, since it is directly coupled to the carriage 154, also returns to the open position.

[00090] Turning to Figures 41-51 there is seen in schematic form various configurations for the electrodes 120, 126 for use in conjunction with the grasper 110. Each of Figures 41 and 43-51 show a cross-section through the instrument jaws as clamped on the tissue to be ablated. Each electrode is formed of a piece of electrically conductive metal that may be plated with a biocompatible material.

[00091] With reference to Figures 41 and 42, the

-21-

electrode geometry consists of a largely rectangular electrode with a window of material removed from the central region. The window area is filled with the insulator material 122, 128. At the clamping surface the electrode insulator material leads away from the electrode on a radius. The electrode material protrudes outside the clamping surface of the insulating material. However, the electrode may also be flush with the clamping surface.

[00092] With reference to Figure 43, the electrode geometry is largely rectangular and the electrode insulator material leads away from the electrode on a radius. The electrode is flush with the clamping surface of the insulator material.

[00093] With reference to Figure 44, the electrode is applied to fill a groove in the insulator material by way of a plating process. The electrode geometry is largely rectangular and the electrode insulator material leads away from the electrode on a radius. The electrode plating is largely flush with the clamping surface of the insulator material.

[00094] With reference to Figure 45, the electrode is formed into a U-shaped element. The electrode insulator material leads away from the electrode on a radius. As shown, the electrode material extends outside the clamping surface of the insulator material. However, the electrode material may also be flush with the insulator clamping surface.

[00095] With reference to Figure 46, the electrode is applied to fill a groove in the insulator material by way of a plating process, with the electrode geometry being largely rectangular. The electrode insulator material creates a small flat surface perpendicular to the closure plane that is largely flush with the surface of the plate or electrode. As shown, the electrode material is flush with the clamping surface of the insulator material. However, the electrode material may also be applied so that it extends outside the

insulator clamping surface.

[00096] With reference to Figure 47, the electrode geometry is largely rectangular and the electrode insulator material leads away from the electrode on a radius. The electrode material extends outside the clamping surface of the insulator material.

[00097] With reference to Figure 48, the electrode configuration is again largely rectangular, with the electrode insulator material creating a small flat surface perpendicular to the closure plane that is largely flush with the surface of the plate or electrode. The electrode is flush with the clamping surface of the insulator material and a temperature sensing means, such as a thermocouple 166 (see also Figures 35 and 39), is positioned in close proximity to the electrode, but electrically isolated from the RF energy.

[00098] With reference to Figure 49, the electrode is applied to fill a groove in the insulator material by way of a plating process. The electrode geometry is largely rectangular and the electrode insulator material leads away from the electrode on a radius.

[00099] With reference to Figure 50, the electrode is applied to the surface of the electrode insulator material by way of a plating process. The electrode geometry is largely rectangular with the electrode insulator material leading away from the electrode on a radius. The electrode plating is largely flush with the clamping surface of the insulator material. With reference to Figure 51, the electrode is round wire made from an electrically conductive metal that may be plated with a biocompatible material. The electrode insulator material leads away from the electrode on a radius. As shown, the electrode material extends outside the clamping surface of the insulator material. However, the electrode material may also be flush with the insulator clamping surface.

[000100] A further embodiment of a grasper according to

-23-

the present invention is shown in Figures 63-65 and is designated generally 250. The grasper 250 has jaws 252, 254 similar in structure to those described above in connection with the embodiments of Figures 28-32 and 33-40, but includes a different actuation mechanism. Specifically, the jaws 252, 254 of the grasper 250 are biased so that they are normally in the closed position, the jaws being moved to the open position by moving the two handle members 256, 258 towards each other. This action serves to withdraw a push-rod 260 (Figure 64), which is pivotally connected to the handle members 256, 258 by links 262, 264. With reference to Figure 65A and Figure 65B. The distal end of the push rod 260 includes two pins 266, 268 which are captured in slots 270, 272 in their respective jaw members 252, 254. When the pins 266, 268 are located in the distal ends of the slots 270, 272, the jaws are in the closed position. The jaws 252, 254 open as the pins 266, 268 move proximally in the slots 270, 272 through the withdrawal of the push rod 260 by the closing of the handle members 256, 258.

[000101] The jaws 252, 254 also include a lost motion connection including a spring to bias the jaws toward the closed position. With reference again to Figure 65A and Figure 65B, the jaws 252 and 254 are pivotally connected to each other by means of a pin 274. The pin 274 is secured to the jaw member 254, but is received in an elongated slot 276 in jaw member 252. The pin 274 is biased to the top of the slot 276, thus biasing the jaws 252, 254 to the closed position, by means of a leaf spring 278 having one end secured to the pin 274 and the other end captured between two studs 280, 282 carried on the jaw member 252.

[000102] Figures 52A-K illustrate a series of 11 different lesions or ablations that may be made using either an open or a minimally invasive technique with the graspers described above. Turning first to Figure 52A, there is seen a view of the heart showing the right and left atriums (as viewed from behind). The heart includes the left atrial

appendage (LAA) and the right atrial appendage (RAA). The right pulmonary veins (RPVs) and left pulmonary veins (LPVs) enter into the top of the left atrium. The superior vena cava (SVC) and inferior vena cava (IVC) are also shown. The mitral valve annulus is designated as MVA, while the tricuspid valve annulus designated TVA. In Figure 52A, 11 different lesions are indicated by the reference numerals 1-11. A method for making each of these lesions is illustrated in the following Figures 52B-K. It should be appreciated that, depending upon a particular patient's indications, the lesions 1-11 may be created in a variety of combinations.

[000103] With reference to Figure 52B, a method for making lesion 1 to circumscribe the right pulmonary veins (RPVs) is shown. This lesion is made completely epicardially in a manner similar to that illustrated in Figures 23-27. Figure 52C illustrates lesion 2, an epicardial ablation that fully circumscribes the left pulmonary veins (LPVs). Again, this lesion may be made in a manner similar to that illustrated in Figures 23-27.

[000104] Figure 52D illustrates a method for making lesion 3, which connects lesions 1 and 2. Lesion 3 is made with only one of the jaws of the graspers being located epicardially. The mating jaw is inserted into the interior of the heart through a small incision which is sealed using a purse-string suture. The incision as illustrated is made interior the lesion 1 encircling the right pulmonary veins (RPVs).

[000105] Lesion 4 connects the lesion 1, which surrounds the right pulmonary veins, to the mitral valve annulus (MVA). It may be made through the same incision and purse-string suture used for making lesion 3. With reference again to Figure 52D, the jaws of the grasper are merely rotated down so that the distal end of the jaw overlies the mitral valve annulus.

[000106] When making lesion 4, care must be exercised in

locating the grasper jaws so that the electrodes, when RF energy is applied, do not damage the mitral valve leaflets. It is known that the electrical signals generated by atrial tissue differ from the electrical signals generated by ventricular tissue. Consequently, the distal tip of one of the jaw members of the grasper includes an EKG sensor so that the EKG of the tissue contacted by the tip of the grasper can be monitored.

[000107] As best seen in Figures 66 and 67, the distal tip of the fixed jaw 116 includes a pair of laterally-opposed bipolar EKG electrodes or sensors 168 spaced slightly distally from the distal-most end of the electrode 120. The sensors 168 are connected to conductive leads 170 (Figure 33) that are adapted to be connected to an EKG monitor (not shown) to provide a display of the EKG. Thus, as the jaws of the grasper are rotated downwardly after making lesion 3, the surgeon can constantly monitor the EKG, looking for the change from an atrial EKG to a ventricular EKG, to facilitate accurate placement of the jaw tip on the mitral valve annulus, and away from the mitral valve leaflets.

[000108] It may also be desirable to make a lesion between the superior vena cava (SVC) and the inferior (IVC). This may be created in two steps, in which lesions 5 and 6 are made. With reference to Figure 52E, an incision with purse-string suture is made approximately midway between the SVC and IVC, with one of the jaws of the grasper being inserted into the incision so as to have its end adjacent the base of the SVC. The lesion 5 is formed and then the instrument is rotated 180° as shown in Figure 52F, to make lesion 6. Lesion 7 may conveniently be made through the same incision and purse-string suture as lesions 5 and 6, as shown in Figure 52G. Lesion 7 extends from between the SVC and IVC out toward the right atrial appendage (RAA).

[000109] A lesion 8 is made between the right atrial appendage and the tricuspid valve annulus (TVA) utilizing an incision and purse-string suture made in the RAA, as

-26-

illustrated in Figure 52H. Lesion 8 is made on the opposite side of the right atrium as lesion 7, and thus is shown in dotted line in Figure 52A. A lesion 9 may also be made circumscribing the right atrial appendage so as to intersect both lesions 7 and 8. As shown in Figure 52I, lesion 9 is made epicardially. A similar epicardial ablation circumscribing the left atrial appendage is designated 10 and illustrated in Figure 52J.

[000110] A final lesion 11 is illustrated that connects lesion 10 circumscribing the left atrial appendage with lesion 2 that circumscribes the left pulmonary veins. As illustrated, the lesion 11 is made utilizing an incision and purse string suture through which the grasper jaw is introduced, the incision being located in the left atrial appendage beyond the lesion 10.

[000111] In a further embodiment, the present device consists of two long, linear, wire-type electrodes, which are in parallel relationship to each other, each approximately 1mm in diameter, and 50mm long. The electrodes are insulated along their entire surface with a thin layer of high dielectric material such as polyamide, except for a thin strip of electrically conductive material that runs along the length of each electrode, in face-to-face relationship with each other. The electrodes are comprised of a high modulus material, such as tungsten or carbon fiber.

[000112] One of the electrodes is designed to be introduced into the interior of a hollow organ through a small puncture wound in the wall of the organ. The second electrode is introduced on the opposite side of the hollow organ wall. The device incorporates a mechanism for advancing each electrode individually, or both simultaneously, in parallel relation with each other. The device also includes a clamping mechanism that brings the two electrodes together so that their exposed conductive surfaces are in face-to-face relation and the electrodes

-27-

exert sufficient pressure to clamp the tissue. Once both electrodes have been advanced to their desired positions, the clamping mechanism is activated which brings the two wires together, and clamps the tissue between the two exposed electrode surfaces. RF energy is then applied between the two electrodes, and the tissue is ablated in a long, continuous, transmural line. A monitoring device measures the voltage, current, impedance, and/or temperature between the two electrodes, and an algorithm determines whether the tissue is fully ablated.

[000113] This device provides a way to achieve and verify a fully transmural and continuous line of tissue ablation by locating the atrial tissue between two bipolar wire electrodes, and clamping the tissue. The forceps consist of two electrode pads of opposite polarity designed to grasp and clamp tissue. A well-known method of determining the status of the tissue between the electrode pads is to monitor the current, voltage, and impedance of the tissue, as done using the Richard Wolf generator for bipolar forceps. It is well known in the art that the ablative status of tissue clamped between two bipolar electrodes can easily be determined by monitoring the increase in tissue impedance as the tissue dessicates.

[000114] This device is to be used with an RF generator that monitors current, voltage, and impedance to determine the state of tissue ablation of the tissue compressed between the inner and outer electrodes. The RF generator will be equipped with an indicator which informs the user of the status of the clamped tissue, and when ablation is complete (i.e., transmural along the entire length of the electrodes).

[000115] This device provides the capability of creating long, transmural lesions through atrial wall tissue of varying thickness because it employs an active bipolar electrode on each side of the atrial wall, and the ablation proceeds from both the inside and outside of the atrial

wall. The device is also unique in that the electrodes are used to compress the tissue to be ablated. This compression is critical because the inside and outside surfaces of the atrium can have irregularities, and a high clamping pressure insures that both electrodes are making good contact with tissue along the full length of each electrode. Clamping the tissue also reduces the distance between the electrodes, and makes the ablation more efficient because the electrical energy is more concentrated. Because of this higher concentration of energy, lower powers and temperatures can be used to achieve complete ablation, and the process is considerably faster.

[000116] As an example, to fully ablate a 5mm deep lesion, 30cm long can take several minutes with an endocardial catheter electrode array, and the temperatures can be as high as 80 to 90 degrees centigrade at the tissue surface with the generator power as high as 40 to 50 watts. In benchtop testing of the present invention in animal hearts, a fully transmural 30mm line through 5mm of tissue was achieved in 5 seconds at 20 watts.

[000117] With reference to Figures 53-54, a further embodiment of the device is shown. The device consists of an inner wire electrode wire electrode 201, an outer wire electrode 202, an inner slider button 203, an outer slider button 204, and a clamping slider tube 205 and button 206. The device body 207 houses the wire electrodes, slider tube and buttons, connector wires 207a and 208, and bipolar connector 209. The device may also include slit needle introducer tip 210.

[000118] The operation of the device begins by advancing the inner electrode wire 201 by advancing the slider button 203. Once the inner electrode 201 is advanced to the desired length, the outer electrode 202 is advanced by advancing slider button 204. Note that further advancement of slider button 204 also advances slider button 203, so that both electrodes 201 and 202 advance simultaneously.

Because of the bend 202a in the electrode wire 202, and the notch 205a in the slider tube assembly 205, the slider tube advances along with the outer electrode 202. Once both electrodes are advanced to the desired length, the slider tube 205 is advanced so that the end 205b of the slider tube 205 contacts the arcuate wire segment 202b of electrode wire 202. Further advancement of slider tube 205 acts to compress the electrode wires 201 and 202 together along the entire effective length L.

[000119] Figures 55 and 56 show two types of electrode wires, a piercing tip (Figure 56), and an obturator, or blunt tip (Figure 55). The electrodes may be similar in construction to those shown in Figures 2-6, which are described above. Figure 57 shows a side view of the instrument tip.

[000120] Figure 58A shows the instrument used to penetrate the wall of a hollow organ, such as the heart. The slit needle 210 penetrates tissue through the wall of the atrium 218. In Figure 58B, the inner wire electrode 201 is advanced through the puncture wound into the interior of the atrium. In Figure 58C, the outer needle 202 is initially advanced onto the external surface of the atrial wall 218. Figure 58D shows the inner 201 and outer 202 needles as they are simultaneously advanced along the inner and outer surfaces of the atrial wall 218. Figure 58E shows the pusher tube 205 advanced to compress the tissue of the atrial wall 218 at location 219. RF energy is then applied between the conductive strips 212 on each electrode to ablate the compressed tissue 219. Figure 58F shows section B-B of Figure 58E, with the inner 201 and outer 202 electrodes compressing the tissue 219. The area of ablated tissue is shown as 220. The alternate electrode configuration of Figure 5 is shown in Figure 58G. Blood cells are represented as 221.

[000121] The compression of the tissue is important because it insures that the exposed electrode surface is not

in contact with any tissue or blood except the clamped tissue to be ablated. Referring to Figures 58F and 58G one can see that the clamping of the tissue between the electrodes insures that only the conductive area is in contact with the clamped tissue. Especially important is avoiding any contact between the conductive area of the electrode and blood in the atrium. Contact between an active electrode and blood in the atrium is major cause of thrombus formation in ablation procedures. The compressed tissue acts to isolate the electrically active surface, and prevents inadvertent energy delivery to other parts of the heart or blood. The outside temperature of the electrode can easily be monitored to insure that the temperature of the insulation in contact with blood remains below a critical temperature (40°C, for example).

[000122] Figure 59 shows a potential series of continuous transmural ablation lines 222 located around the pulmonary veins 223 in the left atrium 224. A series of puncture wounds 225 are shown as one means to achieve the pattern of ablation lines (shown in dot-dash lines).

[000123] Figure 60A shows a method for achieving a circumferential lesion in a pulmonary vein 223. The inner needle 201 is a piercing tip as shown in Figure 56. The needle is advanced completely through the wall of the pulmonary vein until it exits the vein. In Figure 60B, the outer electrode 2 is advanced parallel to the inner electrode 201. In Figure 60C, the electrodes are compressed, and the compressed vein wall tissue 226 is ablated by applying RF energy between the two electrodes. In Figure 60D, the electrodes are released, and the vein wall tissue 226 returns to its original shape. Figure 60E shows the outer electrode 202 retracted back into the instrument body, and the instrument is rotated 180 degrees about the axis of electrode 201.

[000124] Figure 60F shows the outer electrode 202 advanced along the opposite side of the pulmonary vein from the

-31-

ablated tissue 220. In Figure 60G, the electrodes are compressed, and the compressed vein wall tissue 227 is ablated by applying RF energy between the electrodes. Figure 60H shows the position of the electrodes with the pusher tube retracted, and the fully circumferential lesion 220. Figure 60I shows the instrument retracted from the vein, and the circumferential lesion of ablated tissue 220.

[000125] Figures 61A-61J show the instrument used in a method to create a circumferential lesion around a pair of pulmonary veins 226 and 227. In Figure 61A the inner electrode 201 is advanced into the side of the atrial wall 218, just below the ostium of the pulmonary vein 226 by advancing slider button 203. Figure 61B shows electrode 201 and slider 203 fully advanced, and exiting the atrial tissue 218 just below the ostium of pulmonary vein 227. Figure 61C shows outer electrode 202 advanced fully in parallel and to the same length as inner electrode 201 by advancing slider 204. Note that slider tube button 205 has advanced to its intermediate position.

[000126] Figure 61D shows slider button 205 fully advanced, which clamps electrodes 201 and 202 together just below the ostia of the pulmonary veins on the side of the veins indicated by tissue surface 218a, and compresses the atrial wall tissue. RF energy is then applied between the two electrodes, and the clamped tissue 219 is ablated. In Figure 61E, electrode 202 is retracted by retracting slider button 4. The line of ablated tissue is shown as 219a. This line of ablated tissue 219a will be completely continuous and transmural, and connect inner needle entry point 229 with inner needle exit point 230 and extend along the side of the atrial wall.

[000127] Figure 61F shows the device body 207 rotated 180 degrees about the axis of the inner electrode 201 so that the atrial surface 218b on the opposite side of the pulmonary veins is exposed. Figure 61G shows slider button 204 and outer electrode 202 advanced over the opposite

-32-

surface of the atrium 218b. Figure 61H shows slider button 205 advanced, and the electrodes 201 and 202 clamping the tissue 219b just below the ostia of the pulmonary veins 226 and 227 along atrial wall 218b. RF energy is then applied between the electrodes 201 and 202 to ablate the compressed tissue 219b. In Figure 61I the slider button 205 is retracted, and the electrodes release the tissue 219b. The outer electrode is then retracted, exposing the tissue 219b that is now fully ablated as indicated by the line 219b. Figure 16J shows a top view of Figure 61I showing the continuous line of ablated tissue surrounding pulmonary veins 226 and 227, connected by entry point 229 and exit point 230 of internal electrode 201. The electrode is then retracted, leaving a continuous transmural lesion that electrically isolates the pulmonary veins from the rest of the atrial tissue.

[000128] In another embodiment of the invention, a penetrating compressive/tensile electrode is used. Once the jaws are positioned below the ostia of the pulmonary veins, the tissue is partially clamped, allowing continued flow from the pulmonary veins to the left atrium. An electrode needle is introduced which enters the left side of the atrial tissue and exits on the right side into a tip securing point on the lower jaw. This point will prevent the tip from moving axially when a needle is pushed. The lower atrial tissue can be compressed by "pushing" on the needle with a force that compresses tissue between the needle electrode and the lower jaw electrode. Bipolar RF energy is then applied between the needle and lower jaw electrodes to ablate a line of tissue from the needle entry to exit point.

[000129] Once the lower atrial tissue has been ablated, the upper jaw is moved down to contact the tip of the lower jaw. Note that this still provides an open lumen for blood flow from the pulmonary veins to the left atrium. The needle is rotated 180 degrees on its axis so that the

-33-

electrode surface faces up. The needle is then "pulled" to create tension, and exert a compressive force that compresses tissue between the needle electrode and the upper jaw. Bipolar RF energy is then applied between the needle electrode and upper jaw to ablate the tissue. Note that the partial closing of the upper jaw to contact the tip of the lower jaw could be done prior to compressing the lower atrial tissue.

[000130] With reference to Figures 62A-62I the clamping apparatus as generally described above is shown. As illustrated, the device is a "pliers type" apparatus. The device is shown clamped around the atrial tissue below the ostia of the pulmonary veins. In Figures 62B-62D, an electrode needle is advanced through the atrial tissue to contact a receiver at the tip of the device. Figure 62E shows one method of clamping the tissue to a rigid needle electrode, using a non-rigid outer clamping member that flexes either by further motion of the handle as shown or by further extension of the electrode member. Figure 62F shows both sides of the clamping member flexed, and the tissue compressed between. Figure 62G shows the position of the clamping members and electrode prior to tissue clamping. Figure 62H shows these positions during tissue clamping. Bipolar RF energy is applied between the clamping members, and the inner electrode to ablate the atrial tissue, creating a lesion, as shown in Figure 62H. Note also, that if the inner electrode had only one exposed electrode surface, the tissue ablation could be carried out first on one side, then the other, without occluding the lumen between the pulmonary veins and the atrium.

[000131] Figure 62I shows another way to achieve tissue compression by advancing a relatively flexible needle electrode which bends as shown to compress the tissue between the electrode and one of the device jaws.

[000132] Thus, it can be seen that a transmural ablation device and method have been provided that overcome the

-34-

limitations of the prior art. First, current technology involves ablation devices deliver ablation energy to either the inside (endocardium) or outside (epicardium) of the heart. Using these techniques, the tissue ablation proceeds from one wall of the heart through the tissue to the opposite wall. To date, there has been no reliable way to consistently achieve lesions that penetrate the full thickness of the atrial wall (transmural lesions), and there has been no way to determine either continuity or transmuralness of these lesions. If the lesion does not penetrate through enough of the atrial wall, conduction can still occur, and the lesion does not fully block the electrical signals that are causing the arrhythmia. Using an endocardial approach, if the lesion penetrates too far through the wall, critical structures such as coronary arteries, veins, or the esophagus can be damaged on the outside of the heart. Using an epicardial approach, if the lesion penetrates too far, blood can be coagulated, or critical structures such as valves, nodes, or connective tissue can be damaged on the inside of the heart.

[000133] There has also been no reliable and consistent way to safely achieve fully continuous, long (greater than 1cm) lesions in the atrial wall without a high risk of thrombus, damage to critical structures, or extensive damage to the atrial tissue.

[000134] The present invention overcomes these shortcomings because the conductive area of each electrode is very narrow compared to the width of the clamped area. As a result, the thermal damage to the tissue is minimal. In contrast, current technology uses catheter electrodes which are typically 1 or 2mm diameter requiring a lesion width of almost 8mm to achieve a depth of 5mm. Using the present invention, a lesion depth of 5mm with a width of less than 2mm can be achieved. This aspect of the invention allows for longer linear lesions with less power delivery because less tissue is being heated. There is, therefore,

considerably less damage to healthy atrial tissue for a lesion of a given depth and length. Recent efforts in creating linear lesions using endocardial electrodes resulted in ablation of over 20% of the atrial endocardium, and a commensurate decrease in atrial contractility.

[000135] Another advantage of this device is that ablation can be done on a beating heart. Using a high modulus material such as tungsten or carbon fiber would allow a minimum diameter, and a maximum clamping pressure for a given clamping length. Once the device is clamped onto the atrial wall, the position of the electrodes can be verified by visually inspecting the position of the outer electrode before delivery of RF energy. If the clamping pressure is higher than the atrial pressure, then clamping over a coronary artery would cut off blood flow, and the resulting change in the EKG would act as a warning to the user prior to applying RF energy. The clamping will prevent any movement of the electrodes relative to the heart wall, and RF energy can be applied with confidence that the ablated tissue will be contained completely between the two electrodes.

[000136] Another important feature of this device is that the energy transfer is limited to the tissue clamped between the two electrodes. The insulated electrodes protect structures on the outside of the heart from being exposed to RF energy. Because of this limitation of current flow, damage to critical structures can be avoided.

[000137] Another advantage of this device is that it can easily be adapted to a minimally invasive thoracoscopic approach. The device shown has been reduced to a 5mm diameter device, and can probably be reduced to 3mm or less. Using video thoracoscopy, the device could be introduced through a small intracostal incision, and used to create fully transmural linear lesions on a beating heart, possibly under local anesthesia on an anesthetized patient.

[000138] Accordingly, a device for performing transmural

ablation has been provided that meets all the objects of the present invention. While the invention has been described in terms of certain preferred embodiments, there is no intent to limit the invention to the same. Instead it is to be defined by the scope of the appended claims.

WHAT IS CLAIMED:

1. A device for clamping and ablating cardiac tissue comprising:

a first handle member;

a second handle member pivotally connected to the first handle member;

first and second mating jaw members associated with the first and second handle members, respectively, the jaw members each having a distal tip and being movable by the handle members between a first open position and a second clamped position, the jaw members having insulated outer surfaces with convex, opposed mating surfaces, each mating surface having a central peak, the central peak of the first jaw being aligned with the central peak of the second jaw;

a first elongated ablation electrode extending along the central peak of the first jaw member;

a second elongated ablation electrode extending along the central peak of the second jaw member;

the first and second ablation electrodes being adapted to be connected to an RF energy source so that, when activated, the first and second ablation electrodes are of opposite polarity; and

one of said first and second jaw members including a pair of EKG monitoring sensors on the tip spaced distally from its associated ablation electrode for contacting cardiac tissue and being adapted to be connected to an EKG monitor, so that when cardiac tissue is grasped between the first and second jaws, the EKG sensors contact the cardiac tissue and transmit the signals generated by the tissue to the EKG monitor.

2. The device of claim 1 wherein the electrodes are between approximately 3 to 8 cm in length and approximately 0.12 to 0.6 mm in width.

3. The device of claim 1 wherein the electrodes comprise gold-plated copper.

4. The device of claim 1 wherein one of the jaws is

fixed and the EKG monitoring sensors are associated with the fixed jaw.

5. A cardiac tissue grasping apparatus comprising:

first and second grasping jaws, the grasping jaws each having a distal tip and being relatively moveable between open and closed positions; each jaw including a raised electrode and a receding clamping surface in face-to-face relation with the electrode and clamping surface of the other jaw; the clamping surfaces of the jaws comprising an insulating material and the raised, face-to-face electrodes being of opposite polarity and connectible to a power source for providing an electrical current between the electrodes;

whereby when tissue is grasped between said clamping surfaces, the electrodes are substantially entirely contacted by the tissue; and

one of said first and second grasping jaws including a pair of EKG monitoring sensors on the tip spaced distally from its associated electrode for contacting cardiac tissue and being adapted to be connected to an EKG monitor, so that when cardiac tissue is grasped between the first and second grasping jaws, the EKG sensors contact the cardiac tissue and transmit the signals generated by the tissue to the EKG monitor.

6. The apparatus of claim 5 wherein the electrodes are between approximately 3 to 8 cm in length and approximately 0.12 to 0.6 mm in width.

7. The apparatus of claim 5 wherein the electrodes comprise gold-plated copper.

8. The device of claim 5 wherein one of the jaw members comprises a piercing tip adapted to puncture myocardial tissue.

9. The device of claim 5 wherein one of the jaws is fixed and the EKG monitoring sensors are associated with the fixed jaw.

10. A device for clamping and ablating cardiac tissue comprising:

- a first handle member;
- a second handle member;

first and second mating jaw members associated with the first and second handle members, respectively, the jaw members each having a distal tip and being movable by the handle members between a first open position and a second clamped position;

a first elongated ablation electrode extending along the first jaw member;

a second elongated ablation electrode extending along the second jaw member;

the first and second ablation electrodes being adapted to be connected to an RF energy source so that, when activated, the first and second ablation electrodes are of opposite polarity; and

one of said first and second jaw members including a pair of EKG monitoring sensors on the tip spaced distally from its associated ablation electrode for contacting cardiac tissue and being adapted to be connected to an EKG monitor, so that when cardiac tissue is grasped between the first and second jaws, the EKG sensors contact the cardiac tissue and transmit the signals generated by the tissue to the EKG monitor.

11. The device of claim 10 wherein the electrodes are between approximately 3 to 8 cm in length and approximately 0.12 to 0.6 mm in width.

12. The device of claim 10 wherein the electrodes comprise gold-plated copper.

13. The device of claim 10 wherein one of the jaws is fixed and the EKG monitoring sensors are associated with the fixed jaw.

14. A cardiac tissue grasping apparatus comprising:
first and second grasping jaws, the grasping jaws each having a distal tip and being relatively moveable between open and closed positions; each jaw including an elongated electrode and a clamping surface in face-to-face relation with the electrode and clamping surface of the other jaw; the clamping surfaces of the jaws comprising an insulating material and the raised, face-to-face electrodes being of opposite polarity and

connectible to a power source for providing an electrical current between the electrodes; and

one of said first and second grasping jaws including a pair of EKG monitoring sensors on the tip spaced distally from its associated electrode for contacting cardiac tissue and being adapted to be connected to an EKG monitor, so that when cardiac tissue is grasped between the first and second grasping jaws, the EKG sensors contact the cardiac tissue and transmit the signals generated by the tissue to the EKG monitor.

15. The apparatus of claim 14 wherein the electrodes are between approximately 3 to 8 cm in length and approximately 0.12 to 0.6 mm in width.

16. The apparatus of claim 14 wherein the electrodes comprise gold-plated copper.

17. The device of claim 14 wherein one of the jaw members comprises a piercing tip adapted to puncture myocardial tissue.

18. The device of claim 14 wherein one of the jaws is fixed and the EKG monitoring sensors are associated with the fixed jaw.

FIG. 1

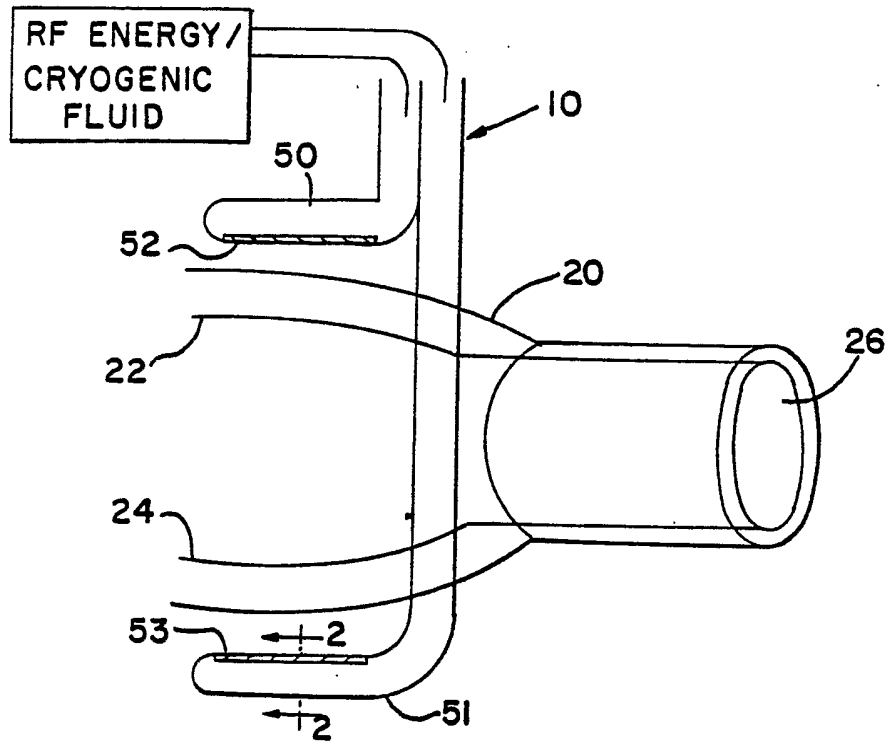

FIG. 2

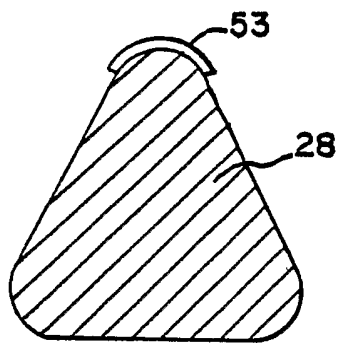

FIG. 3

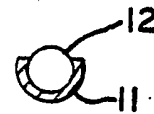

FIG. 4

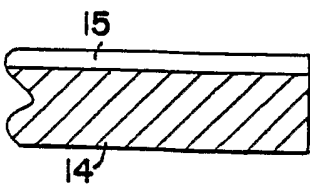

FIG. 5

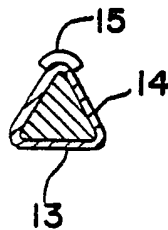

FIG. 6

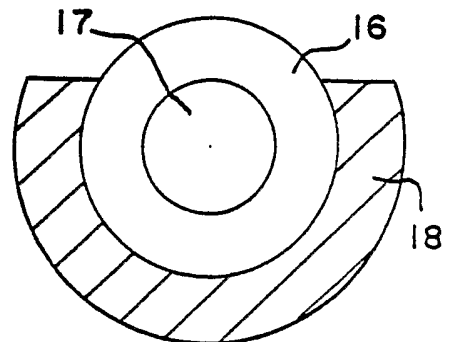

FIG. 7

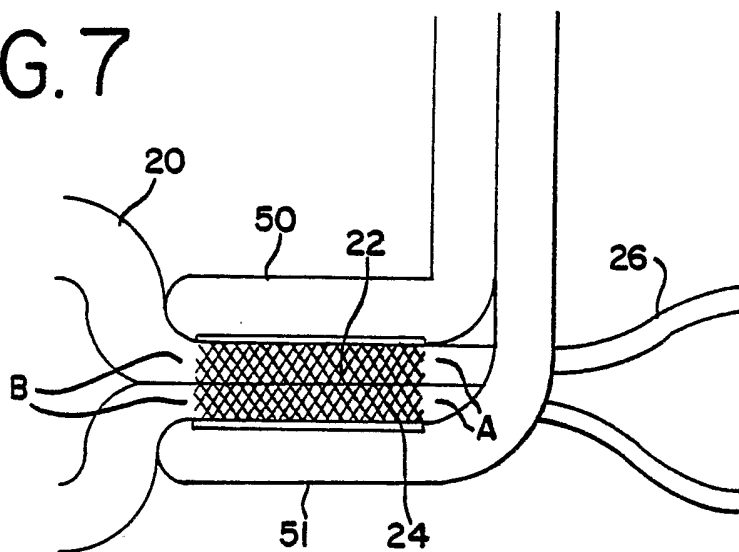

FIG. 8

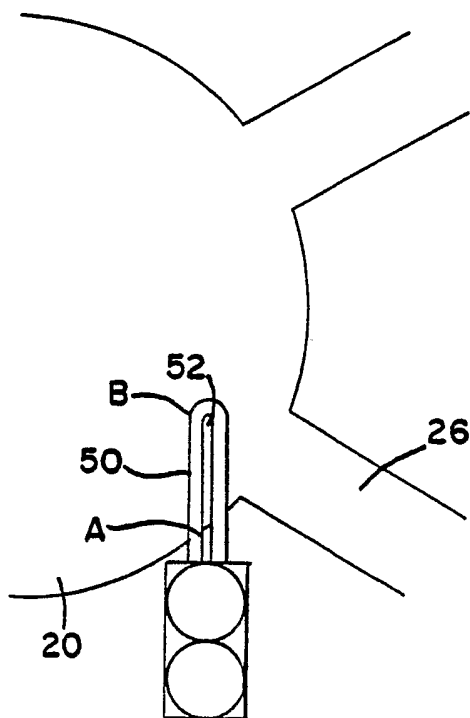

FIG. 9

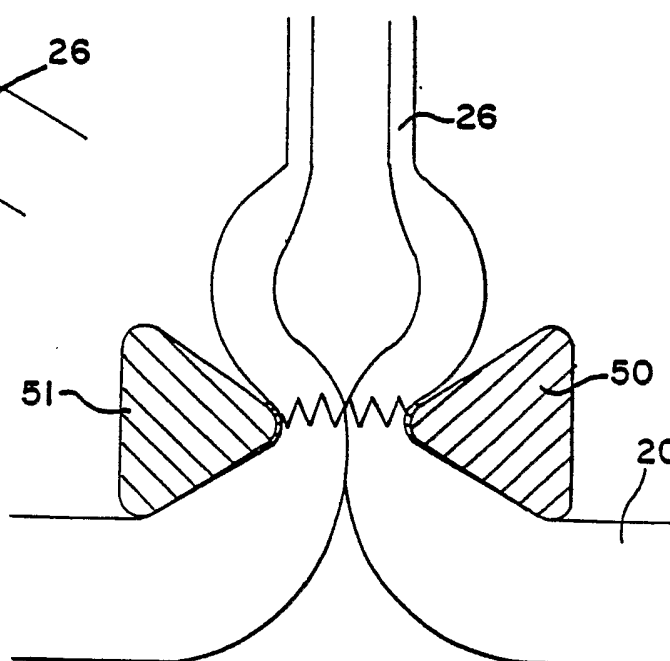

FIG.10

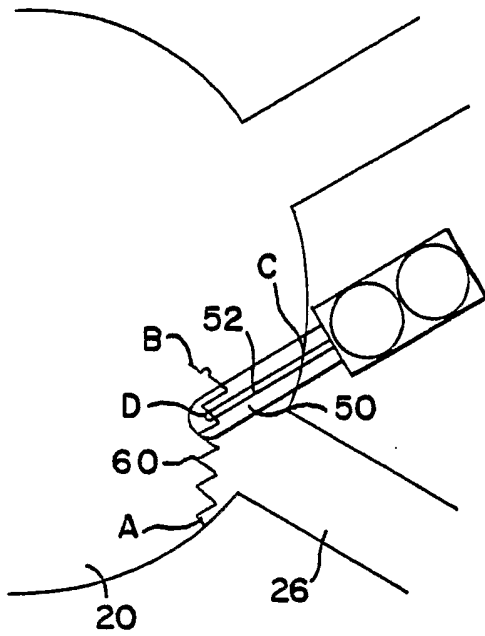

FIG.11

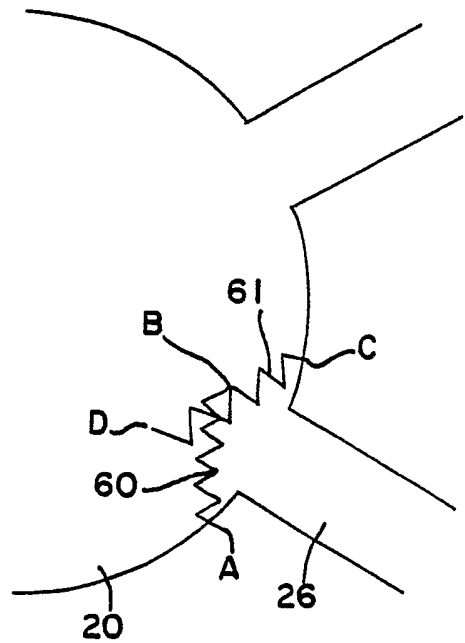

FIG.12

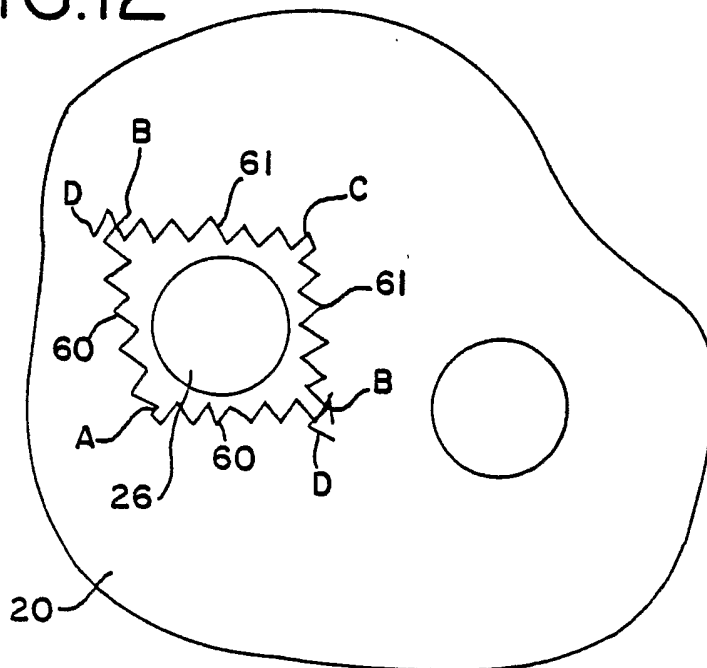

FIG. 13

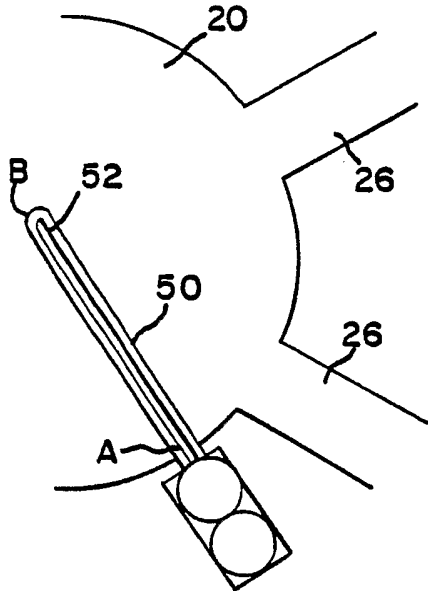

FIG. 14

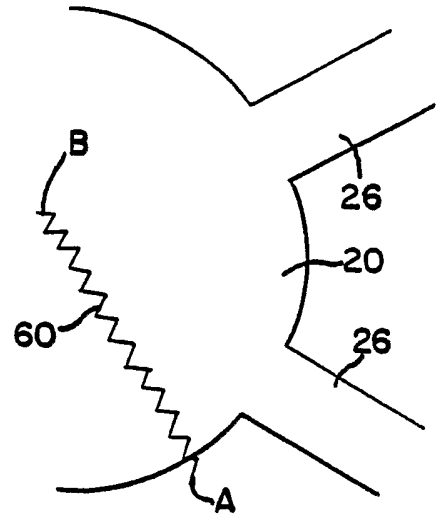

FIG. 16

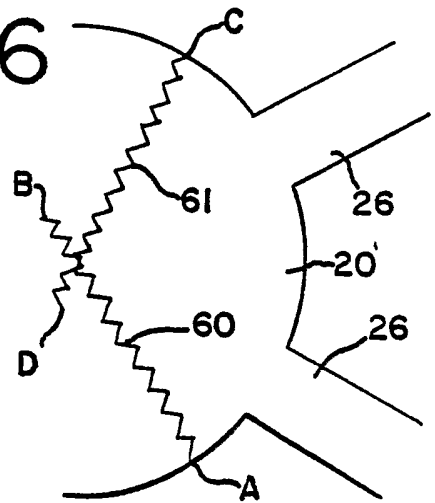

FIG. 15

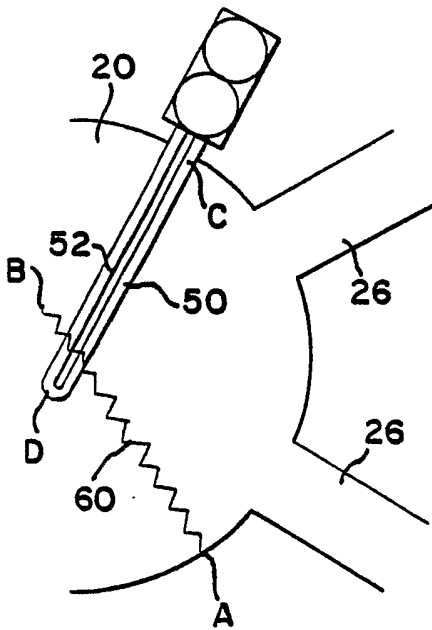

FIG. 17

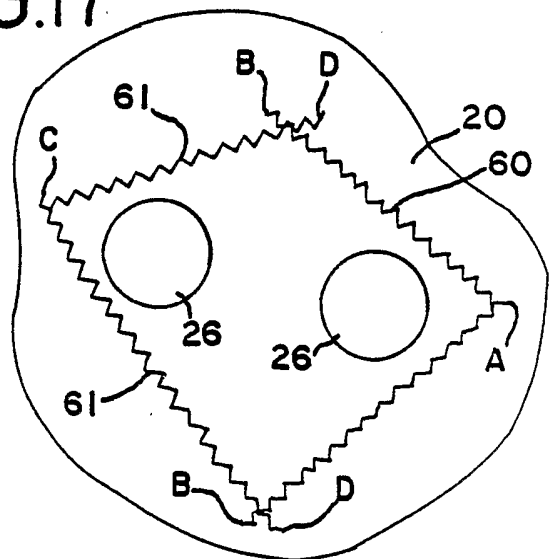

FIG. 19

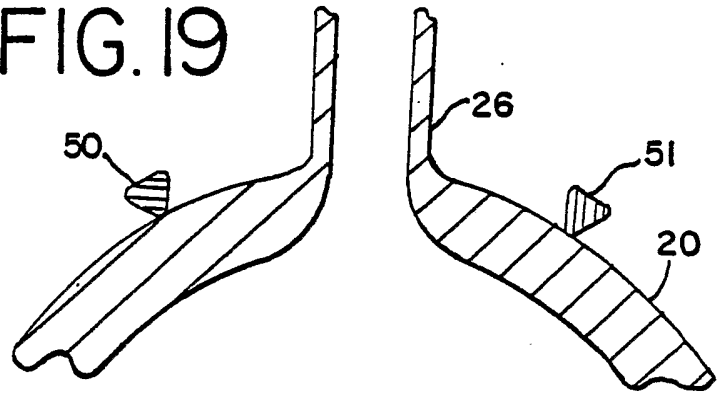

FIG. 18

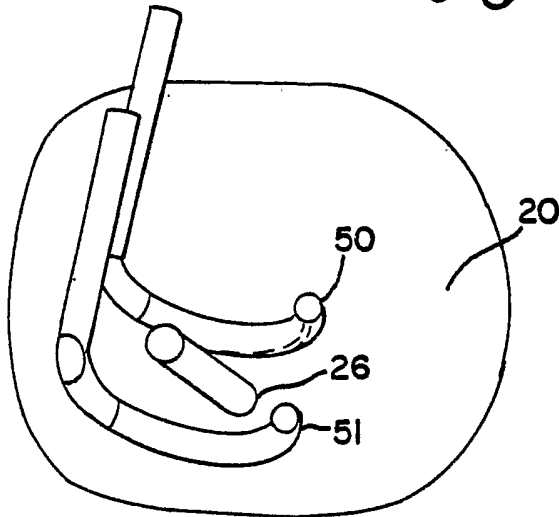

FIG. 21

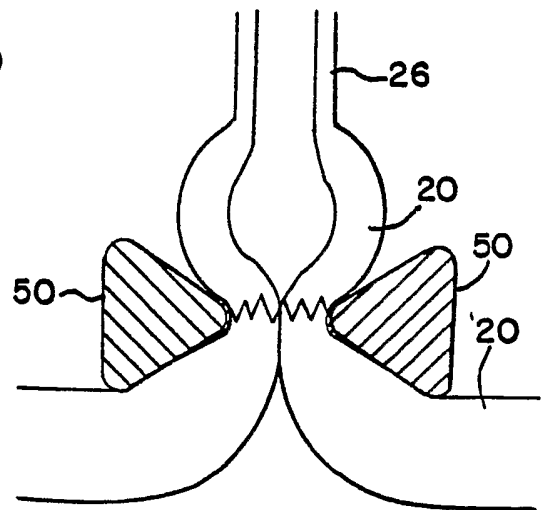

FIG. 20

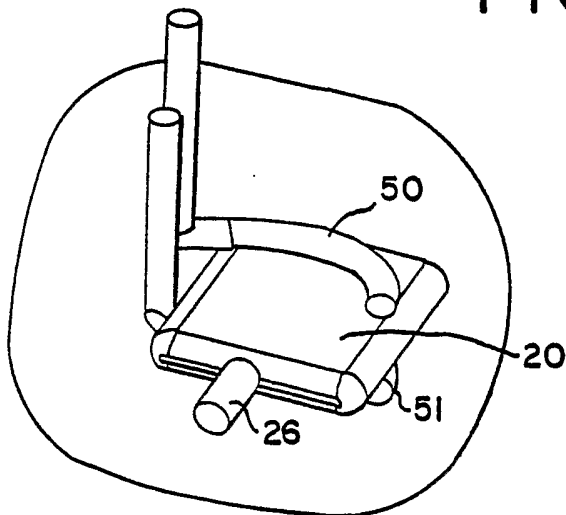

FIG. 22

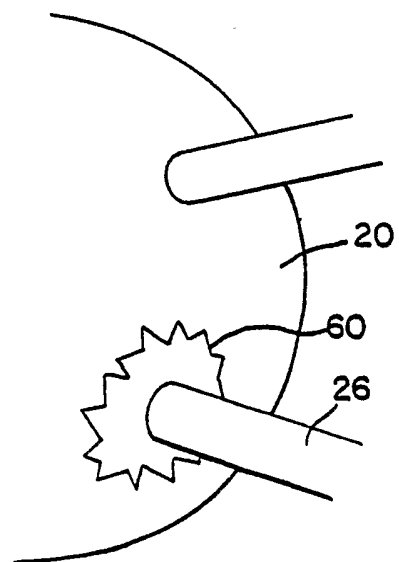

FIG.24

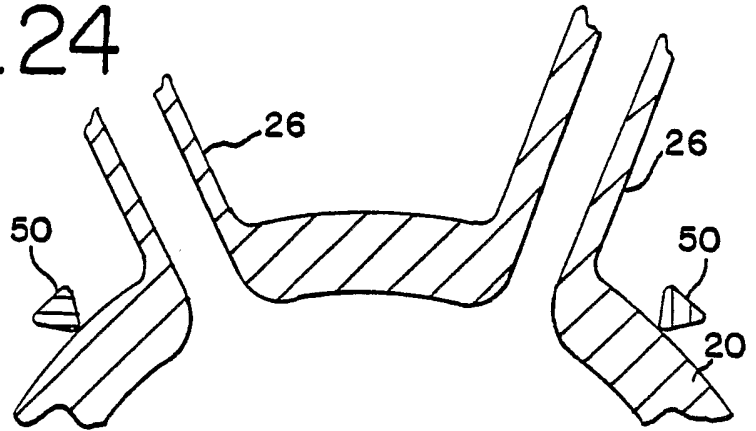

FIG.23

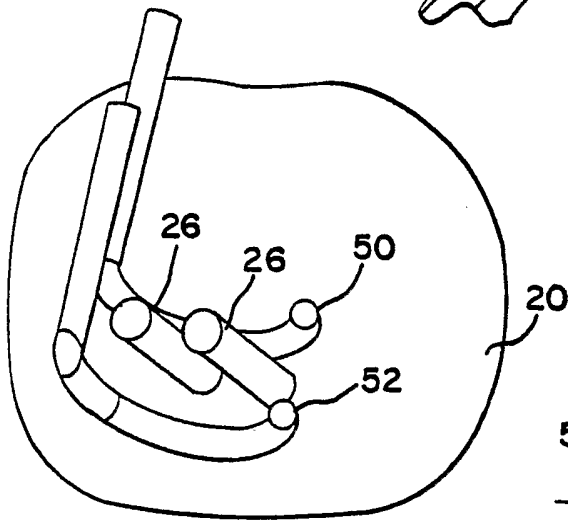

FIG.26

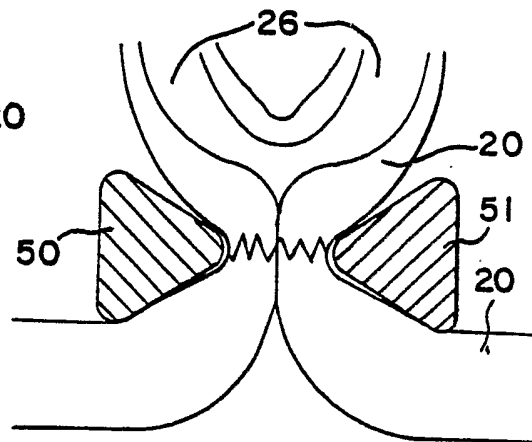

FIG.25

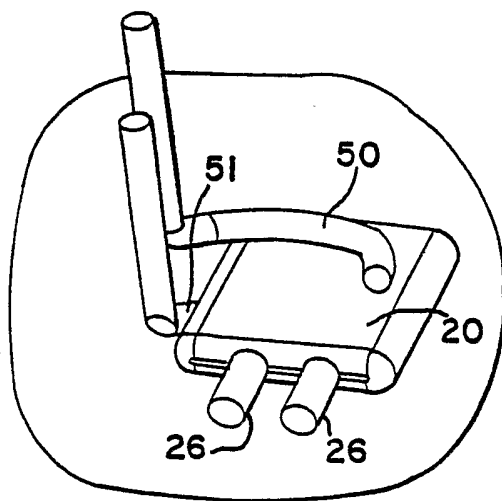
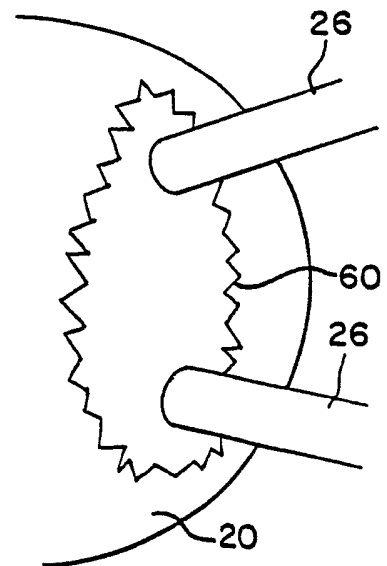
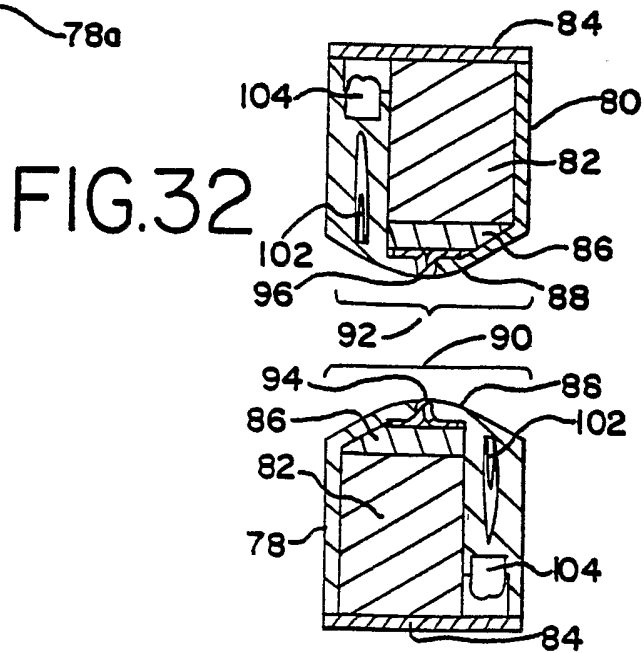
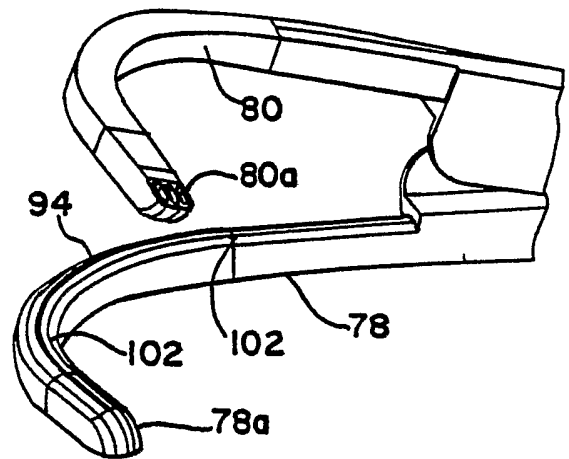
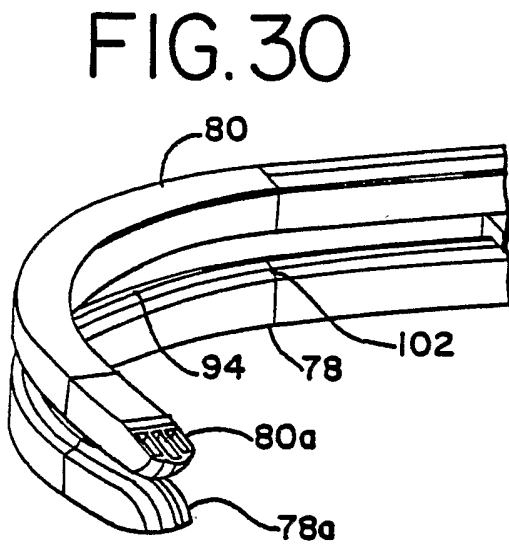
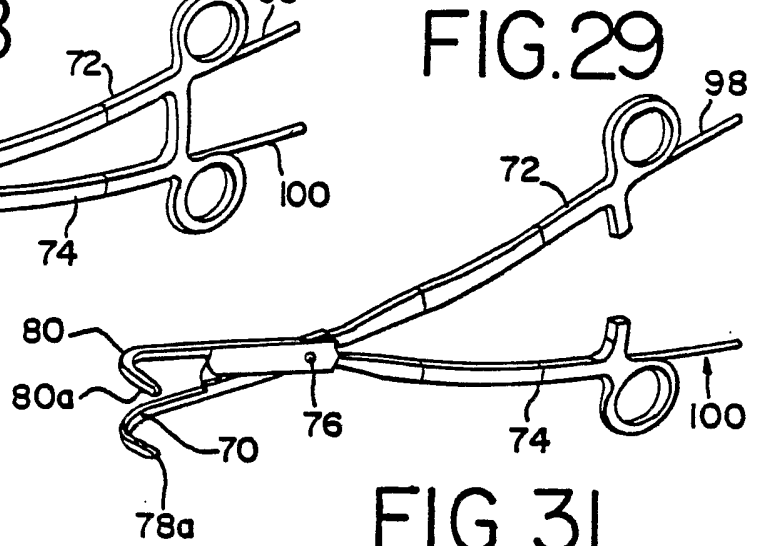
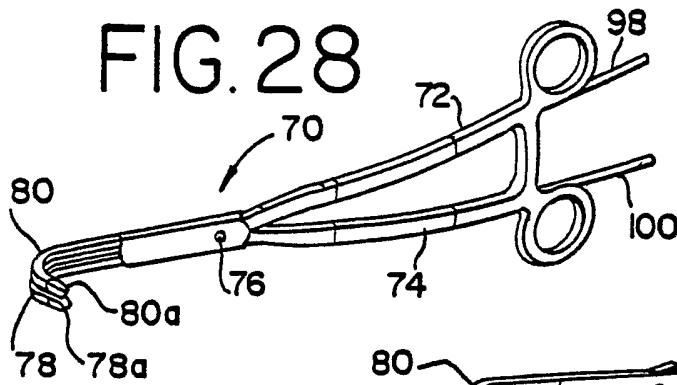

FIG.27





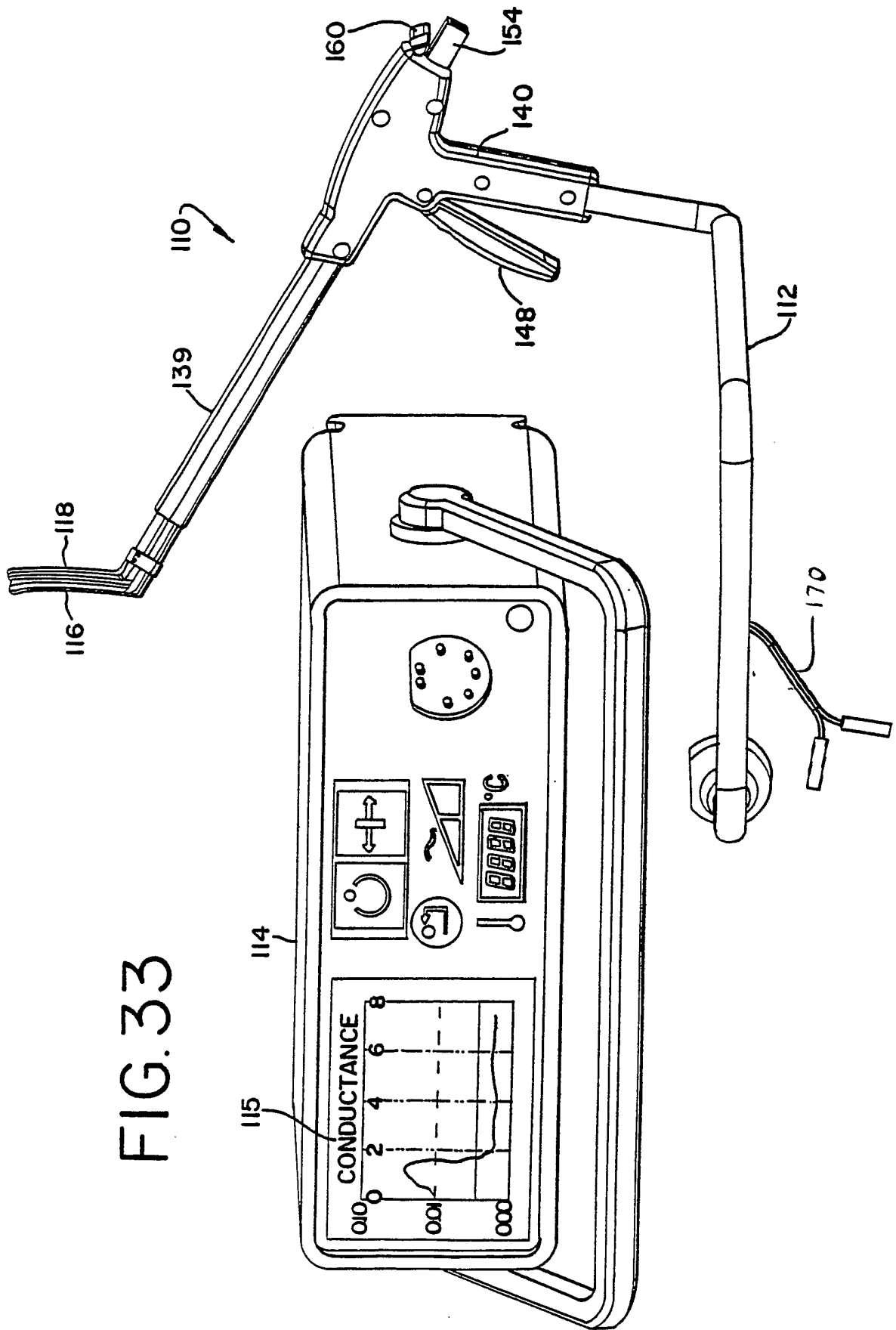
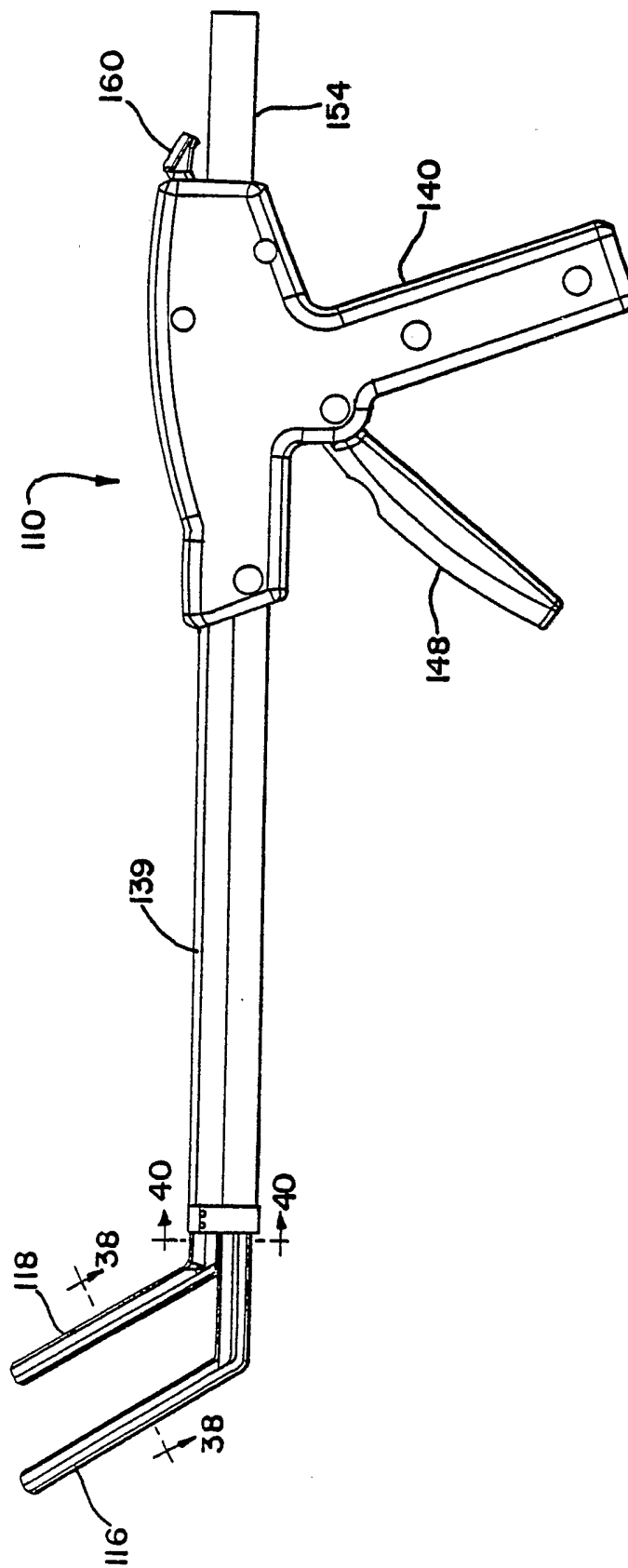

FIG. 33

FIG. 34



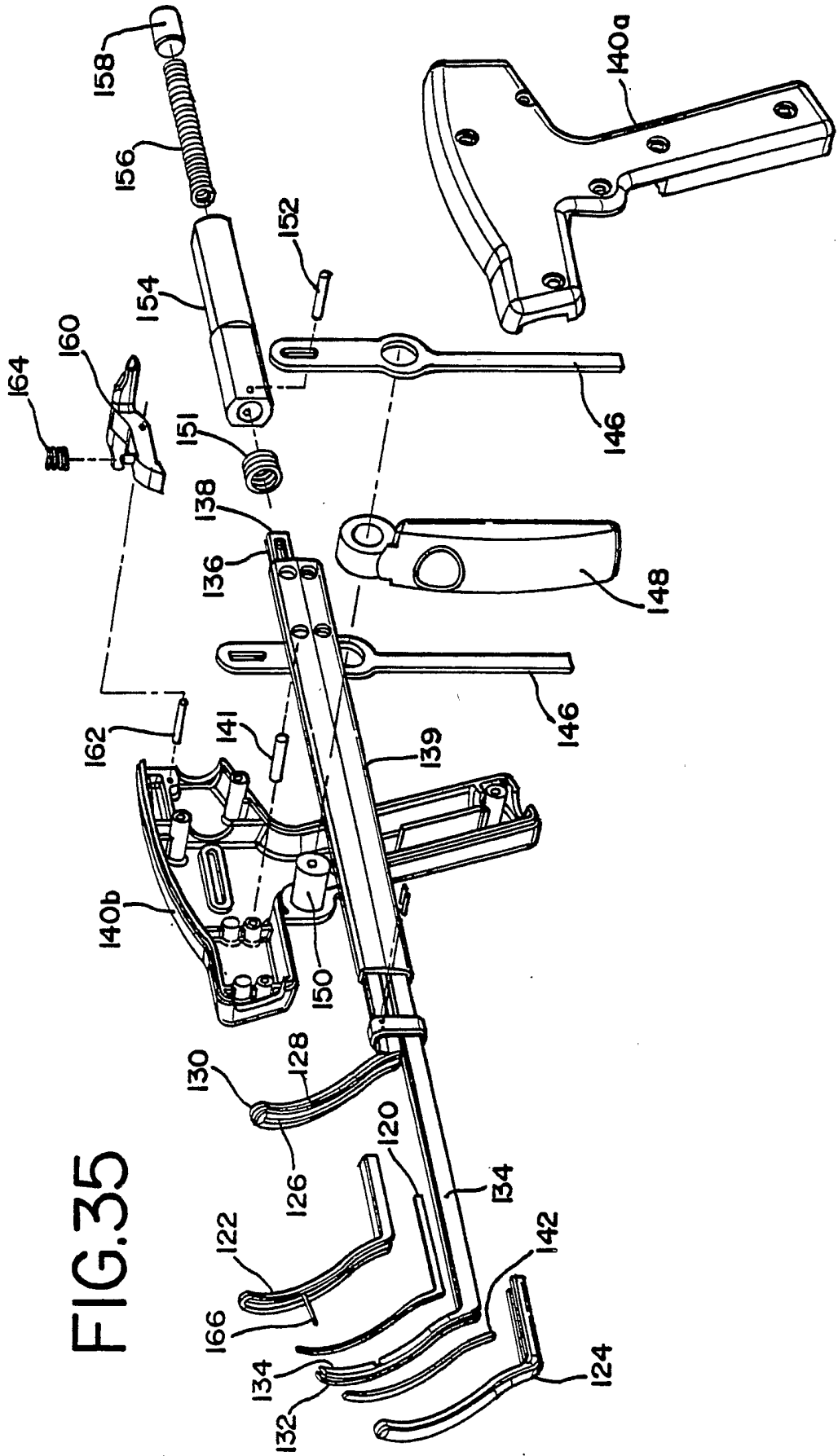

FIG.35

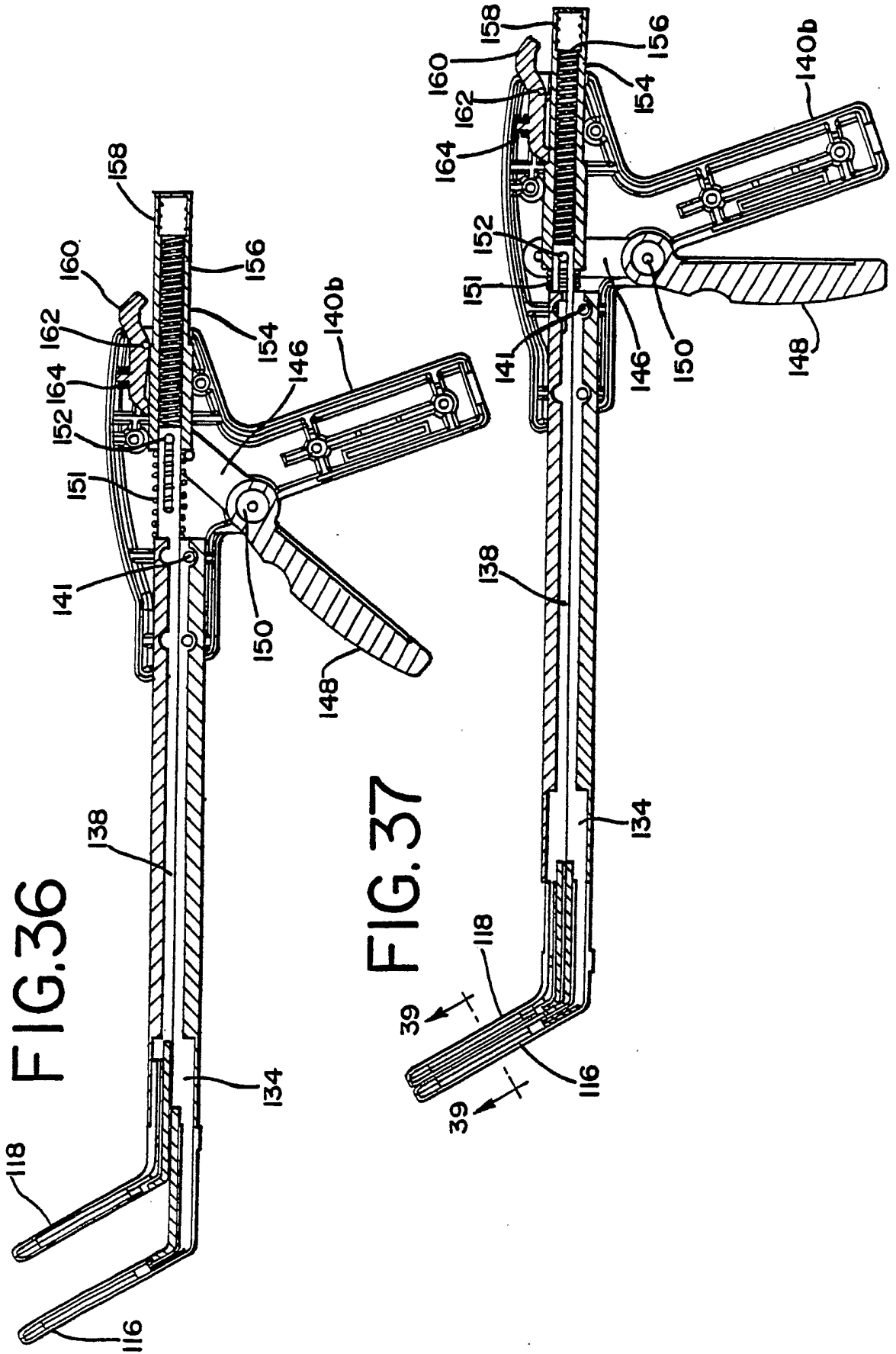

FIG.38

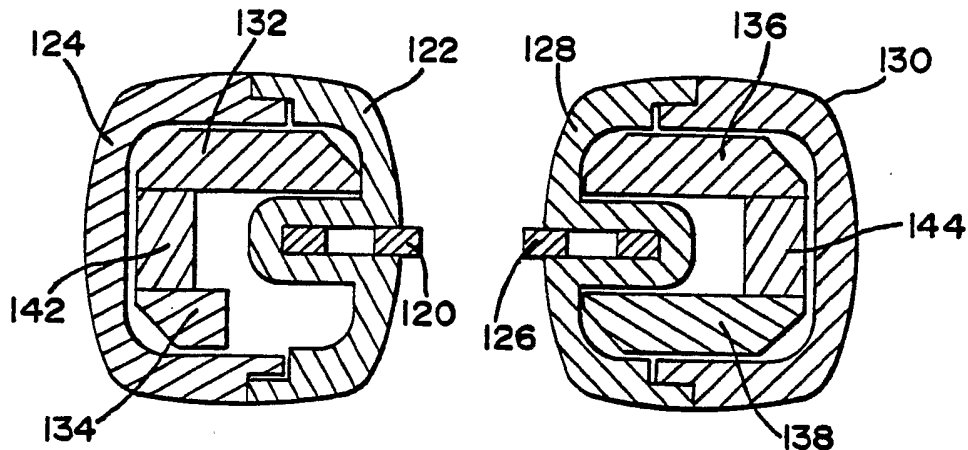

FIG.39

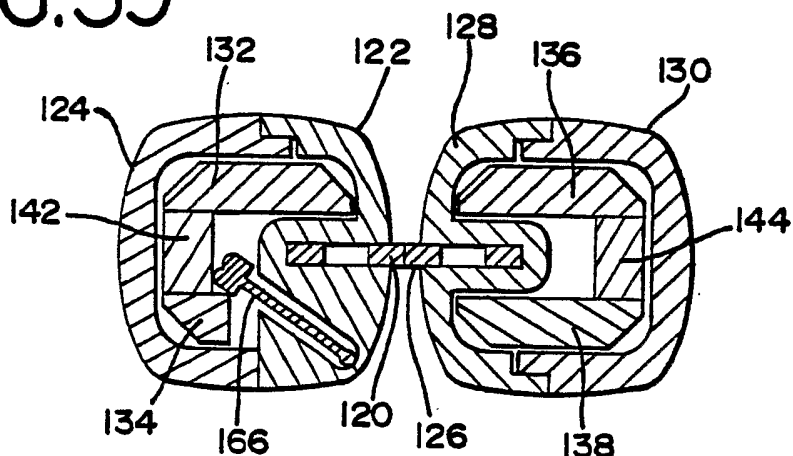

FIG.40

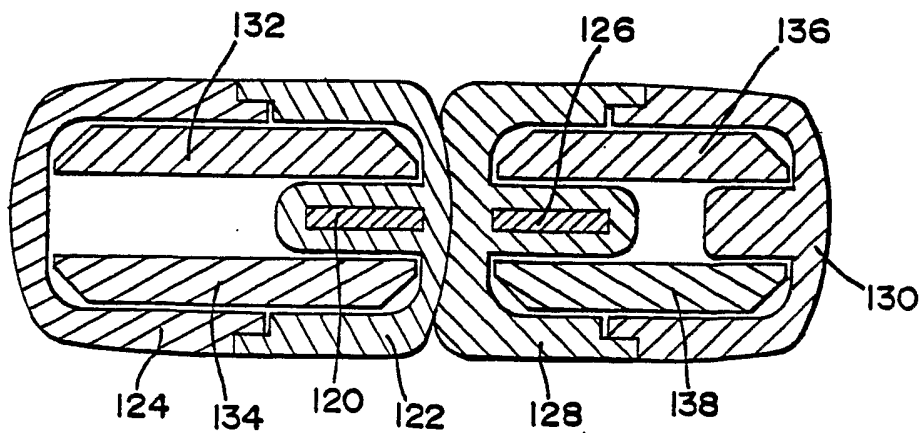

FIG.41

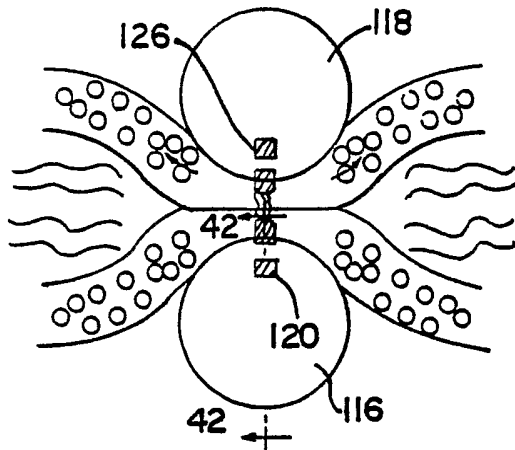

FIG.42

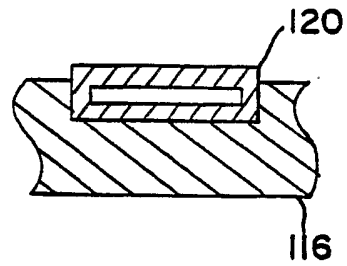

FIG.43

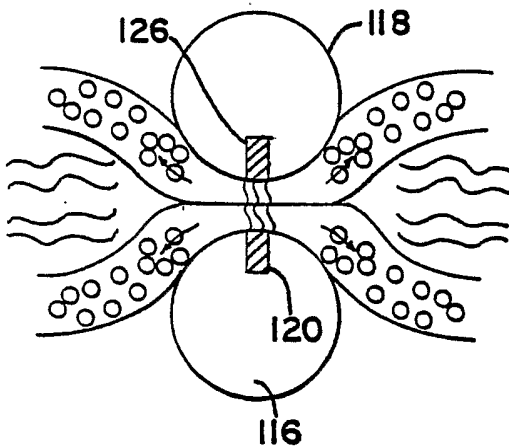

FIG.44

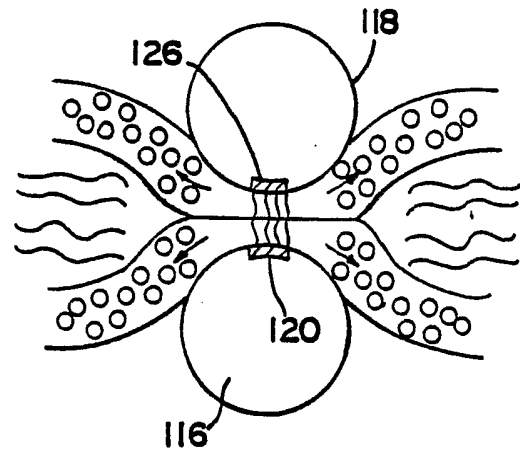

FIG.45

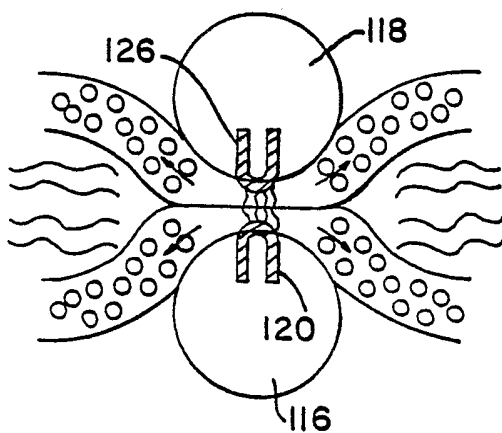

FIG.46

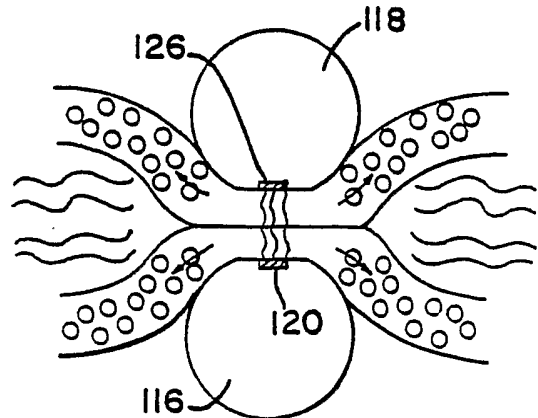

FIG.47

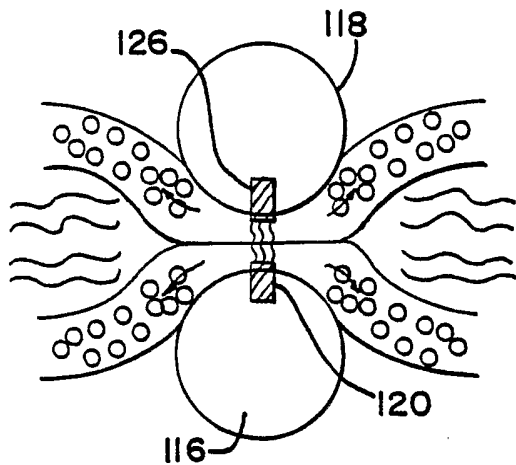

FIG.48

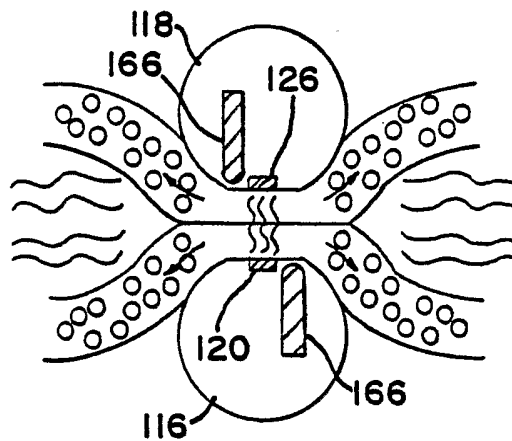

FIG.49

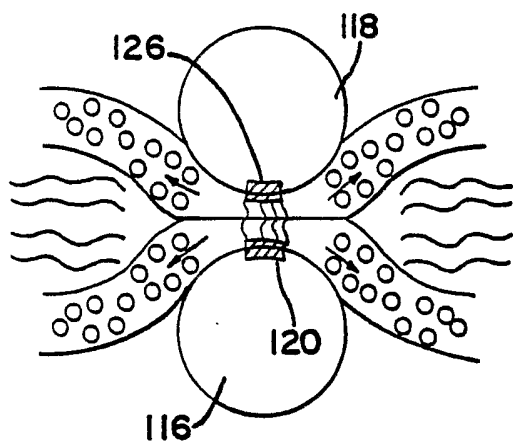

FIG.50

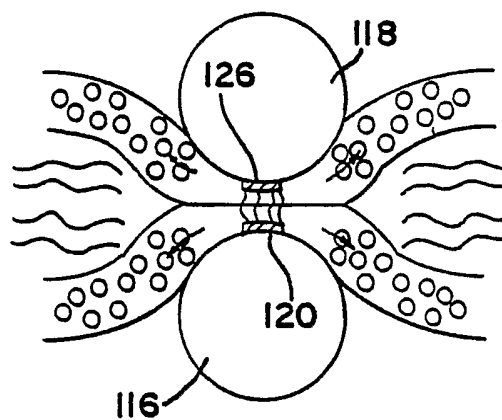

FIG.51

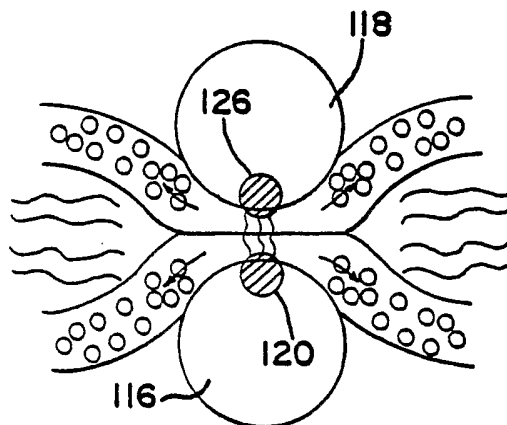

FIG.52A

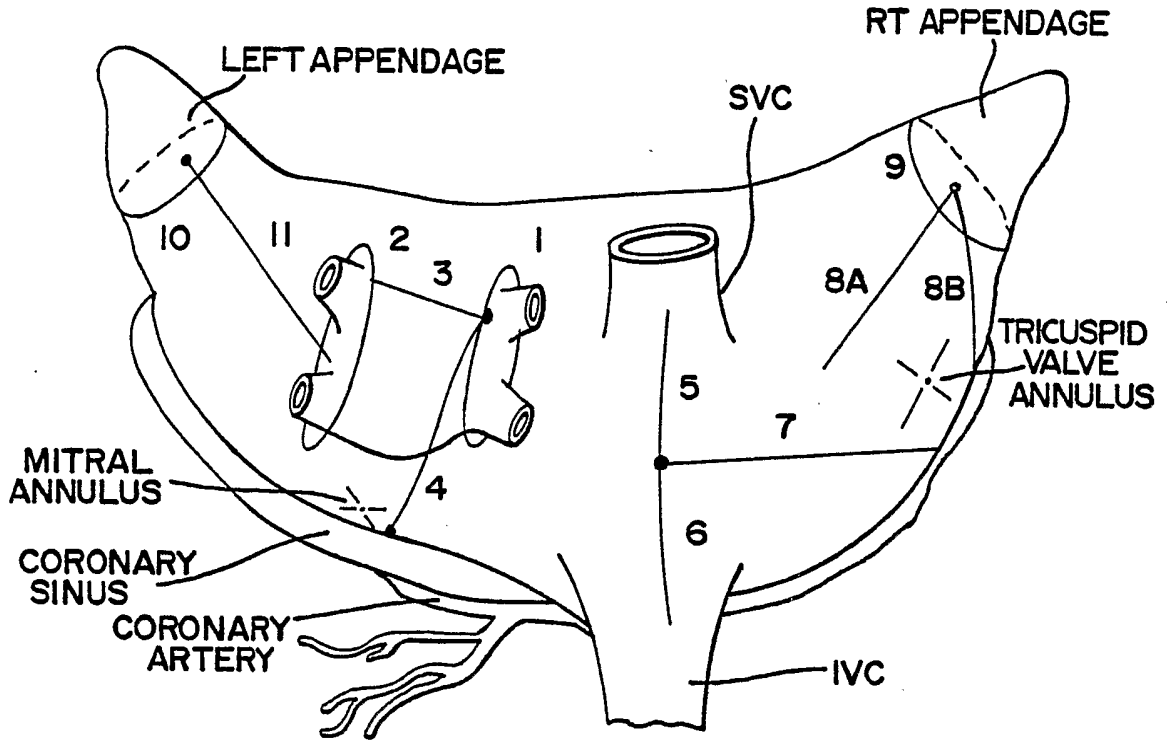

FIG.52B

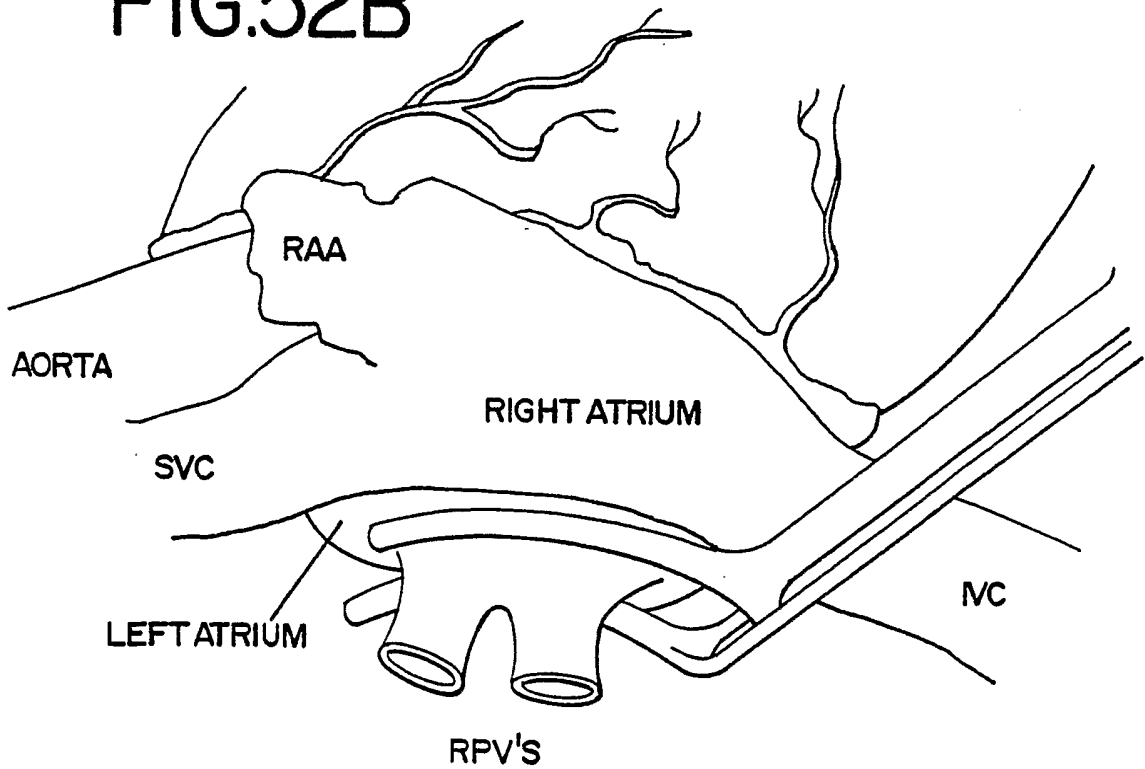

FIG.52C

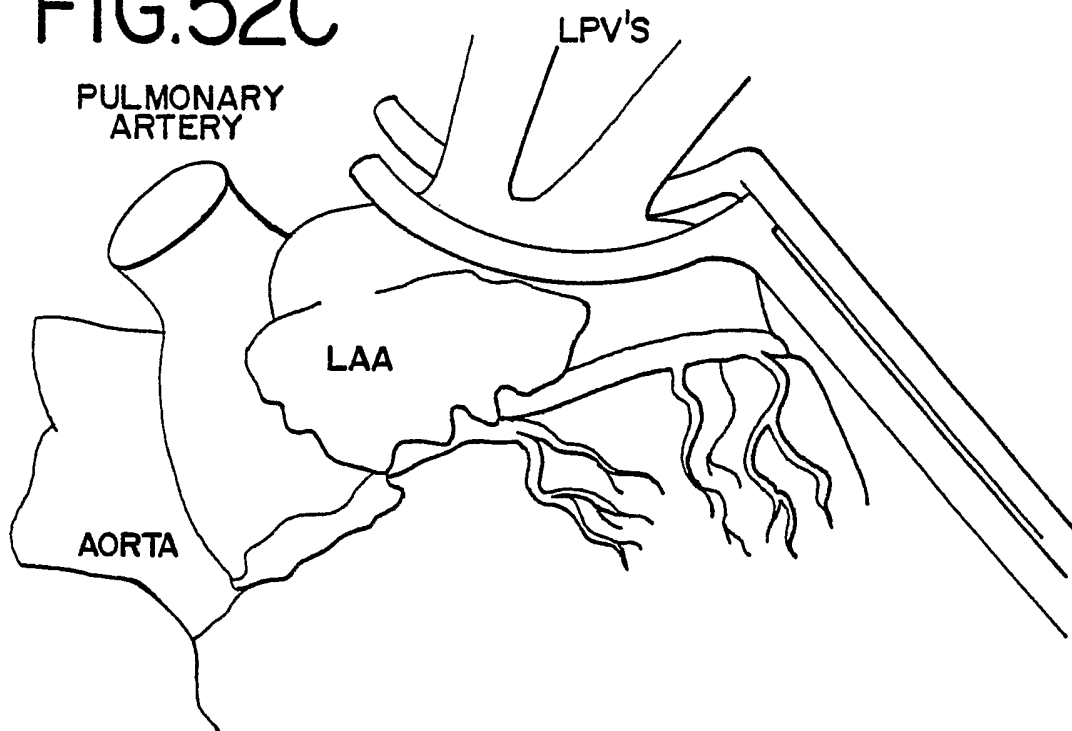

FIG.52D HEART LIFTED

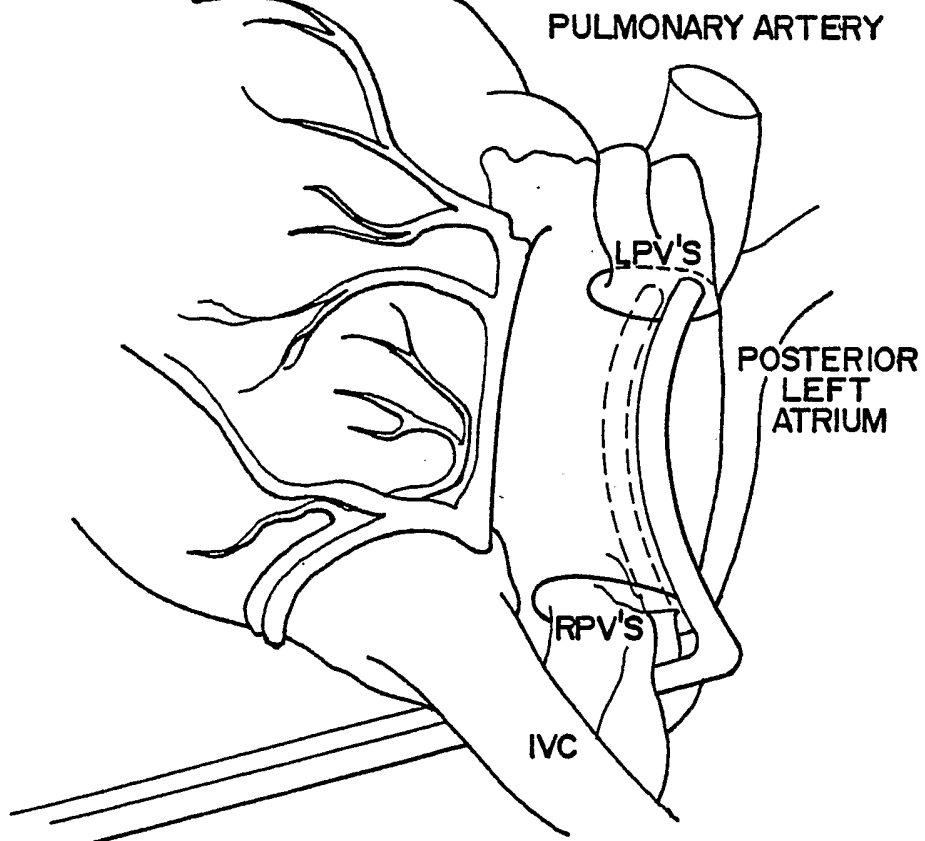

FIG.52E

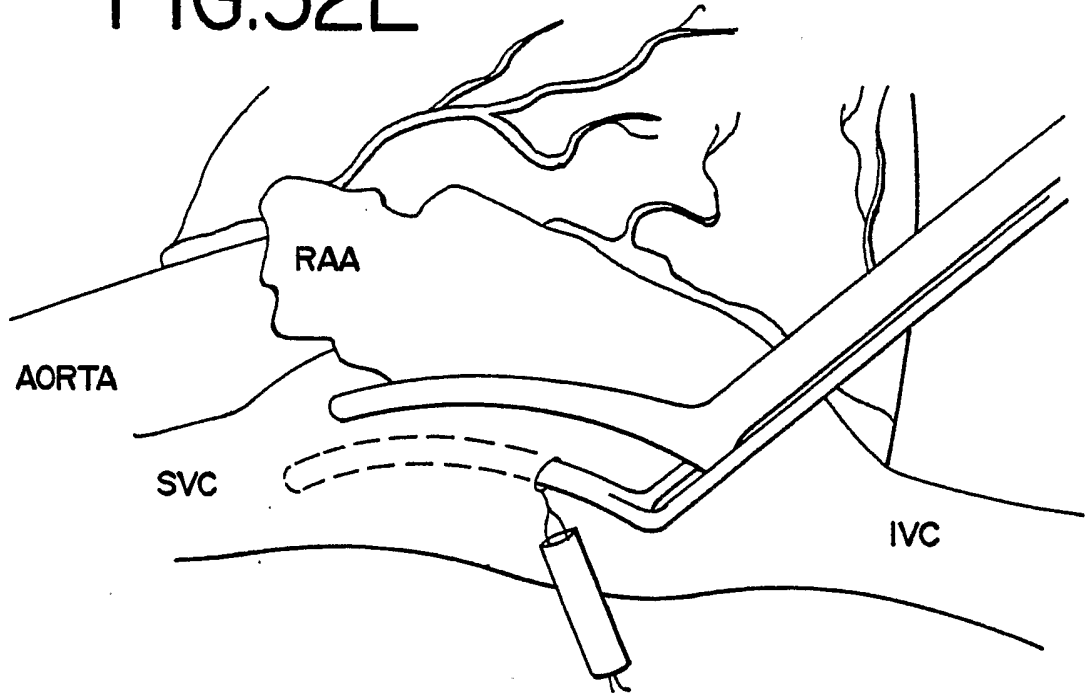

FIG.52F

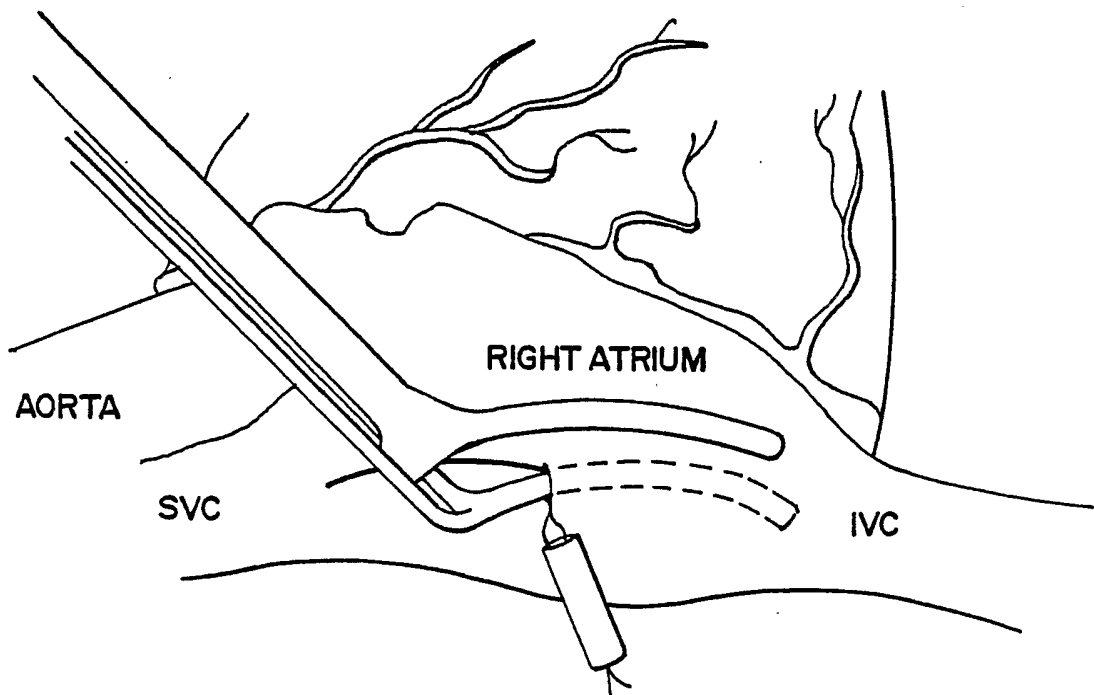

FIG.52G

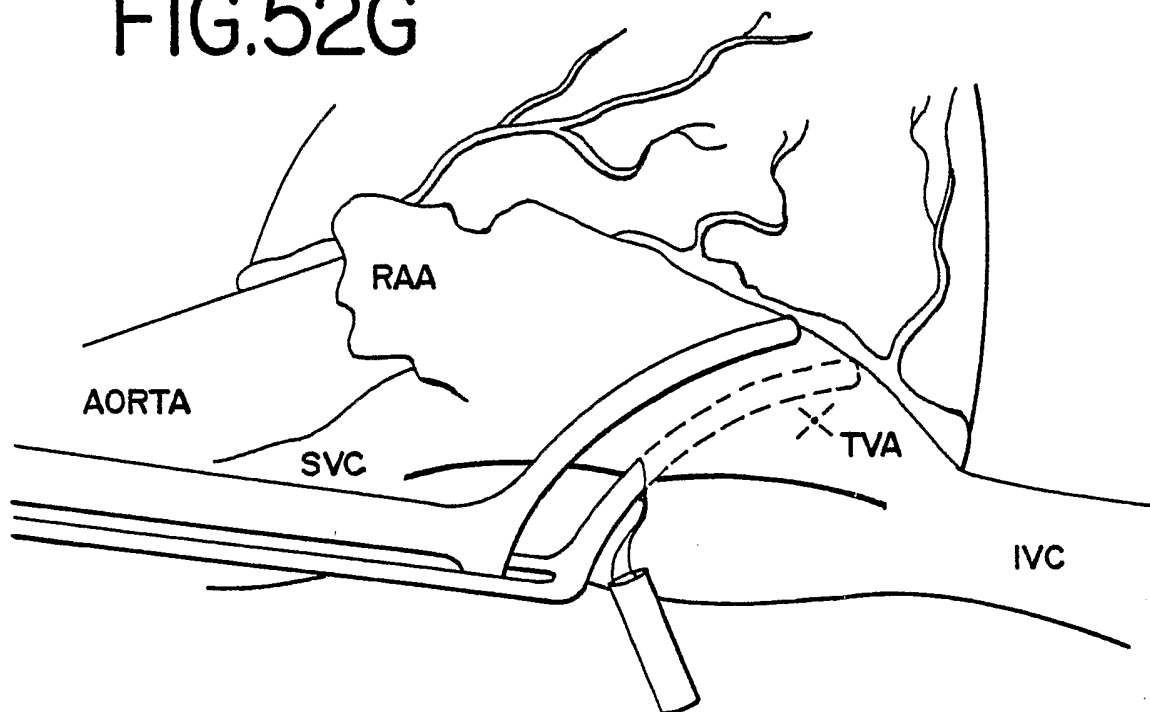

FIG.52H

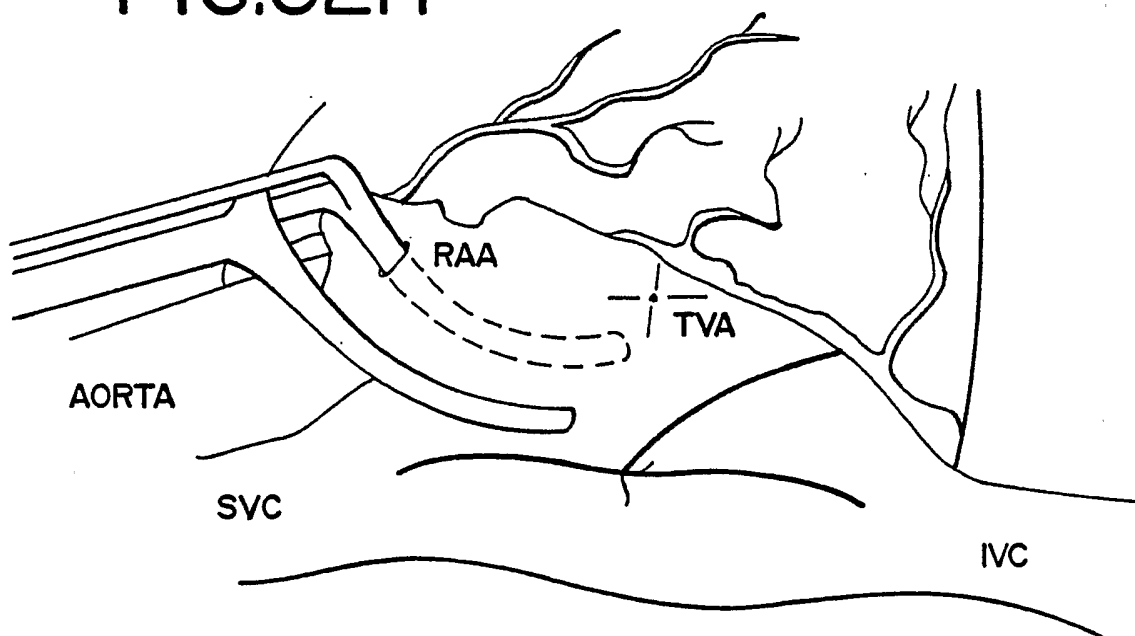

FIG.52I

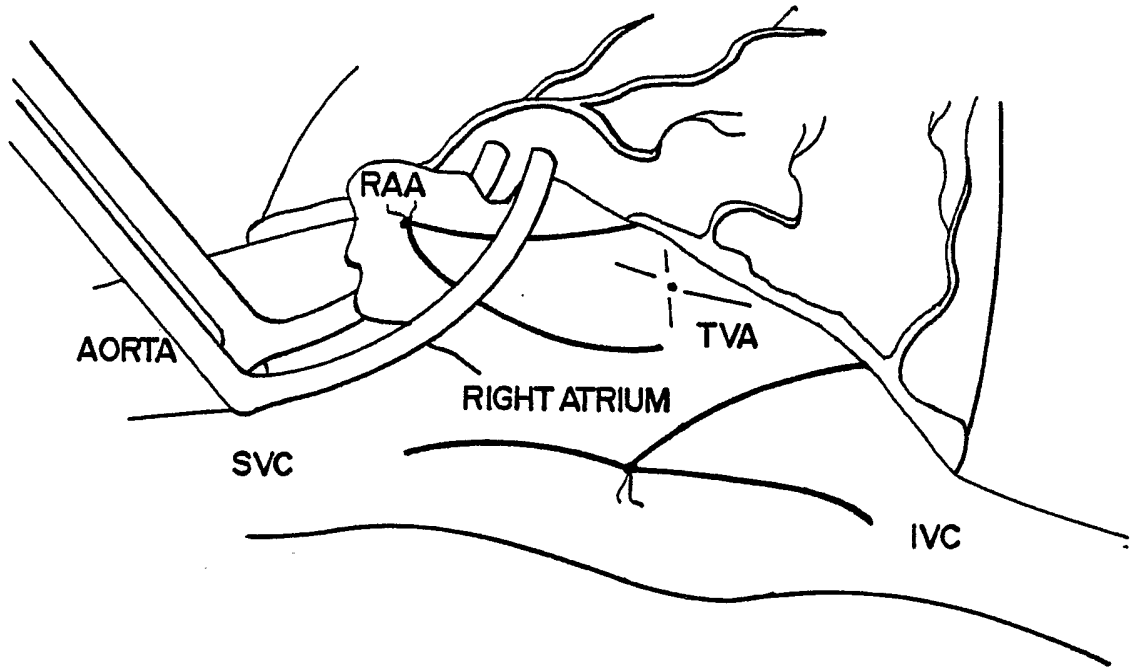

FIG.52J

PULMONARY ARTERY

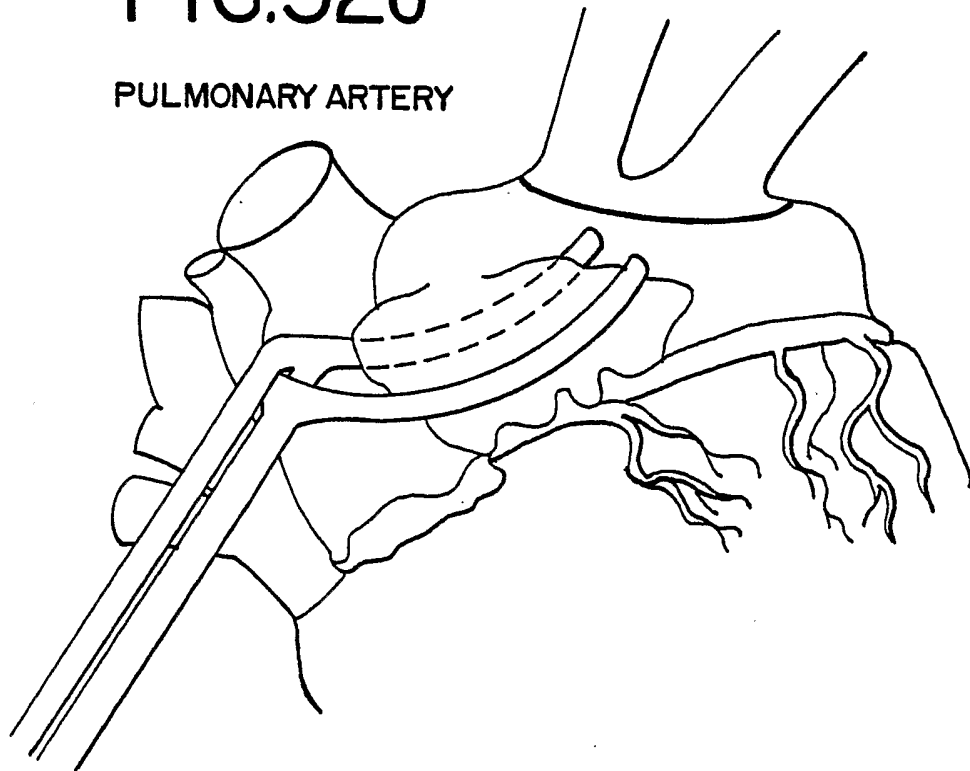
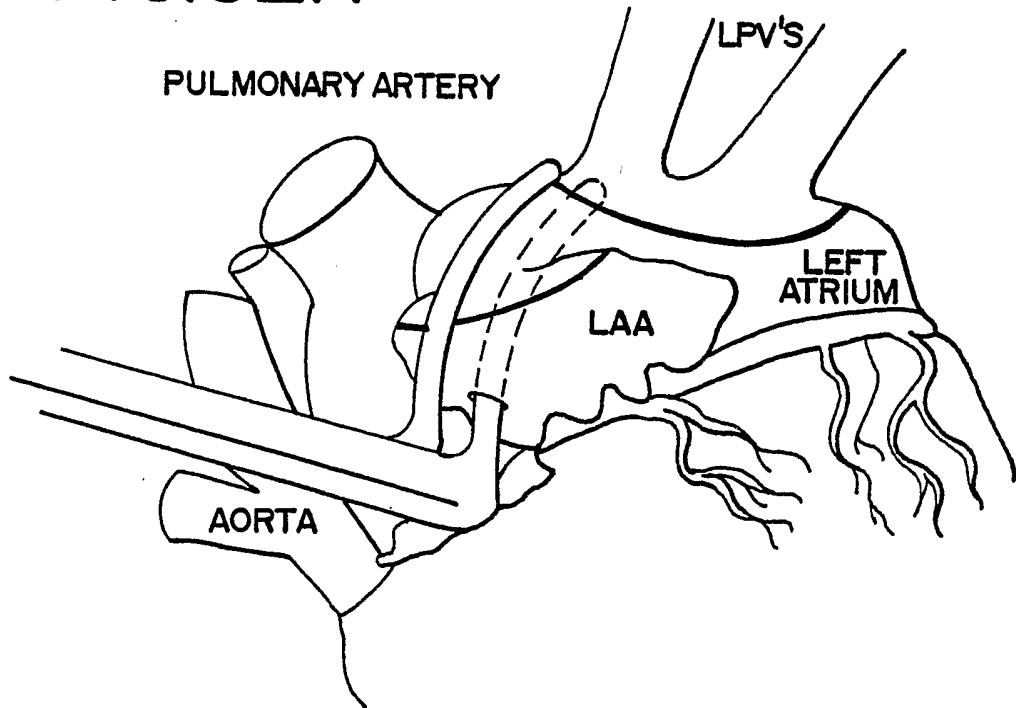

FIG.52K



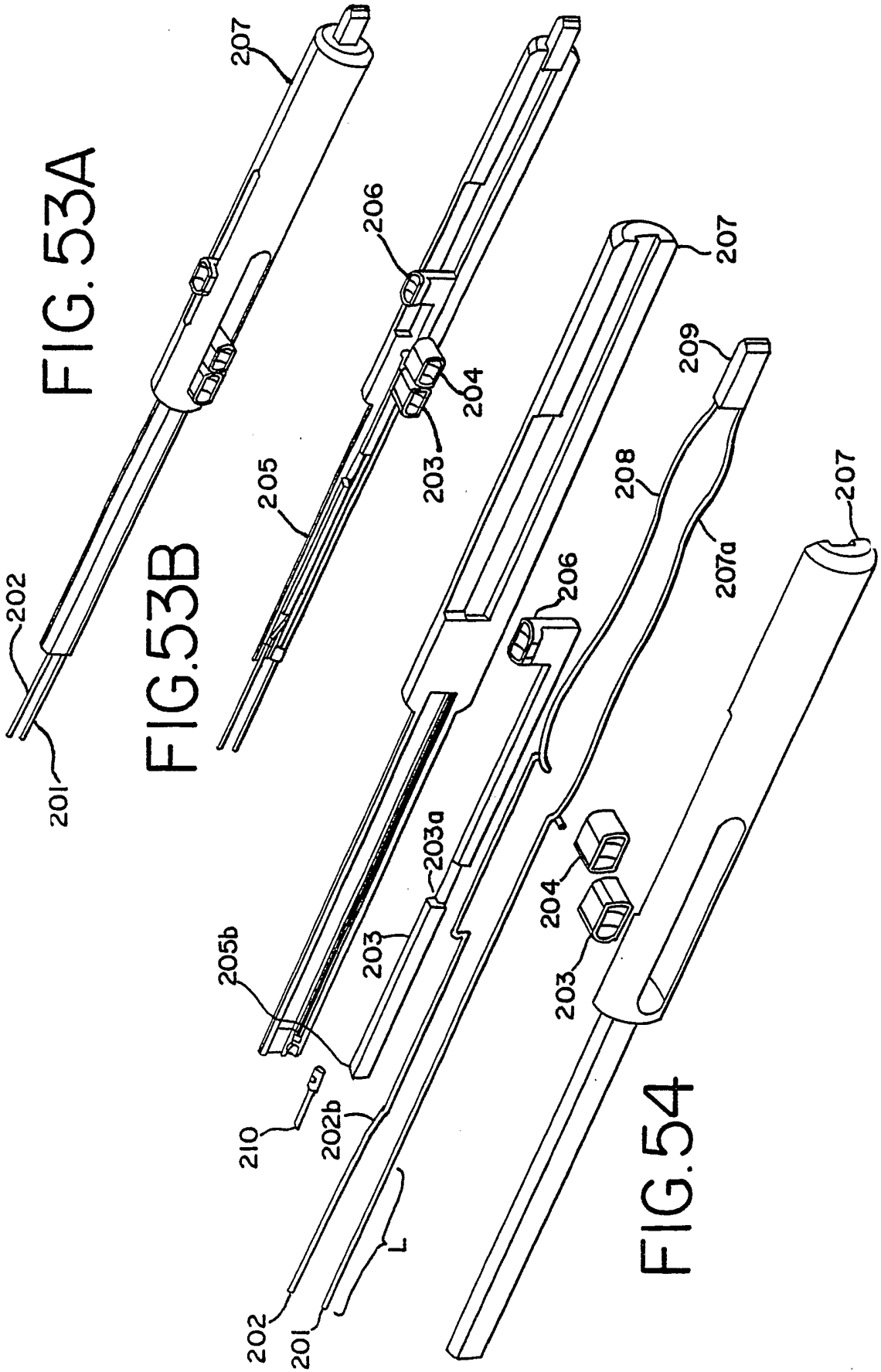

FIG. 55

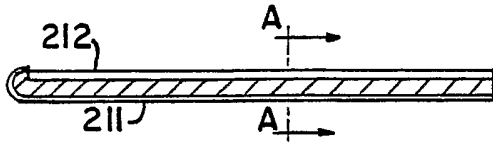

FIG. 56

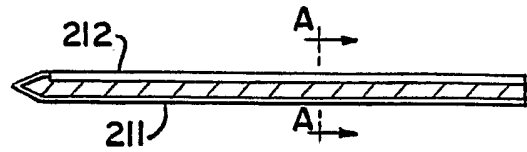

FIG. 57

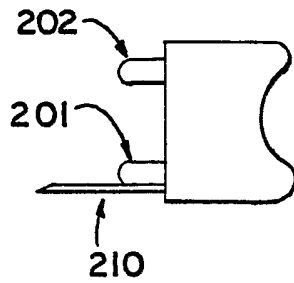

FIG. 58A

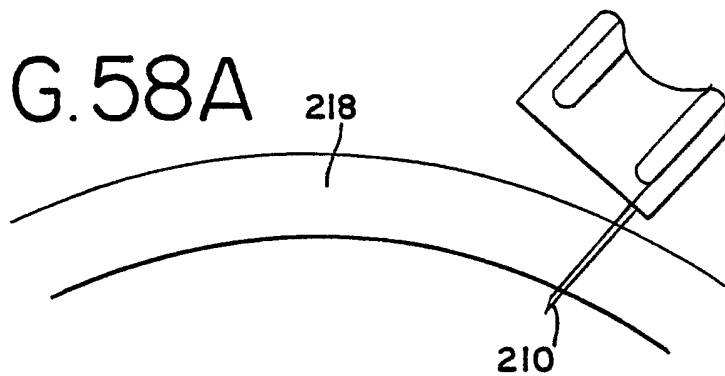

FIG. 58B

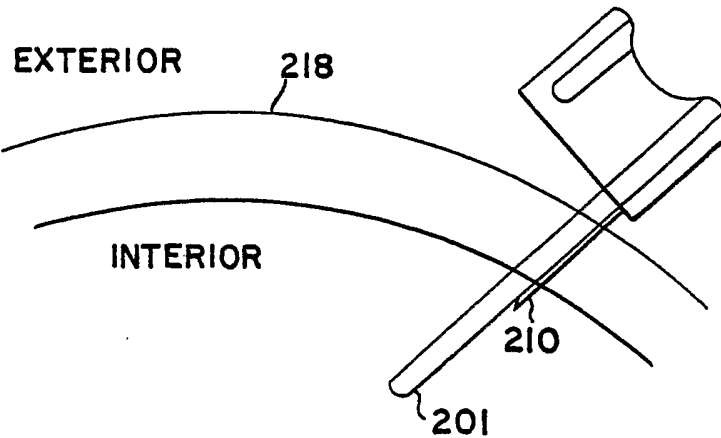

FIG. 58C

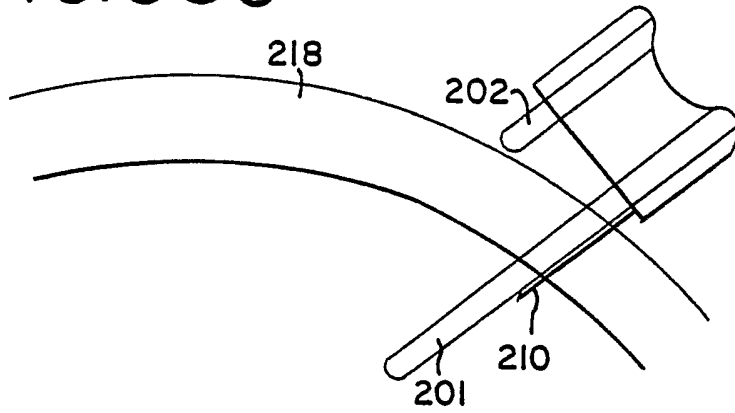

FIG. 58D

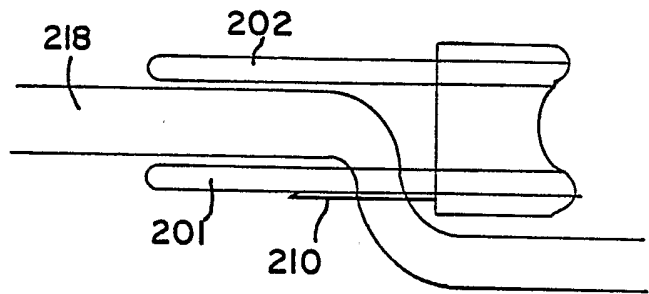

FIG. 58E

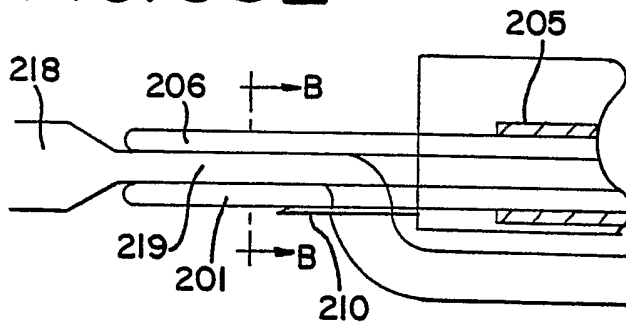

FIG. 58F

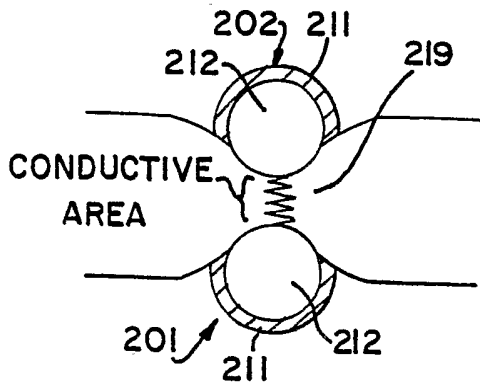

FIG. 58G

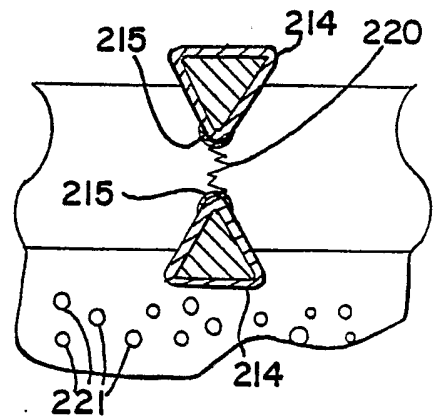

FIG. 59

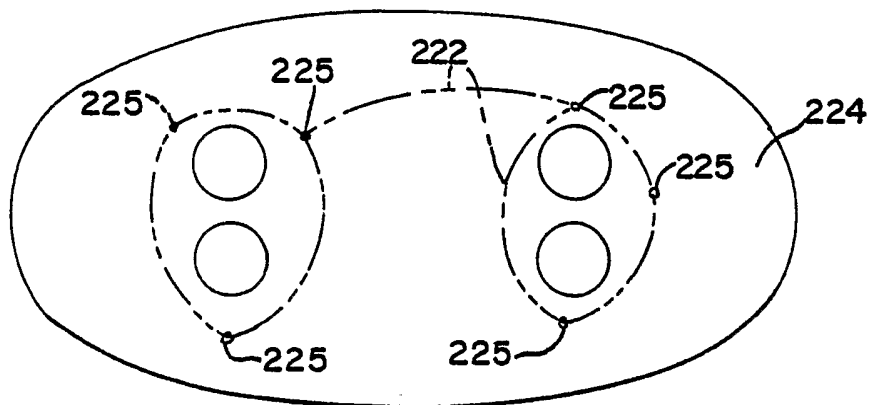

FIG. 60A

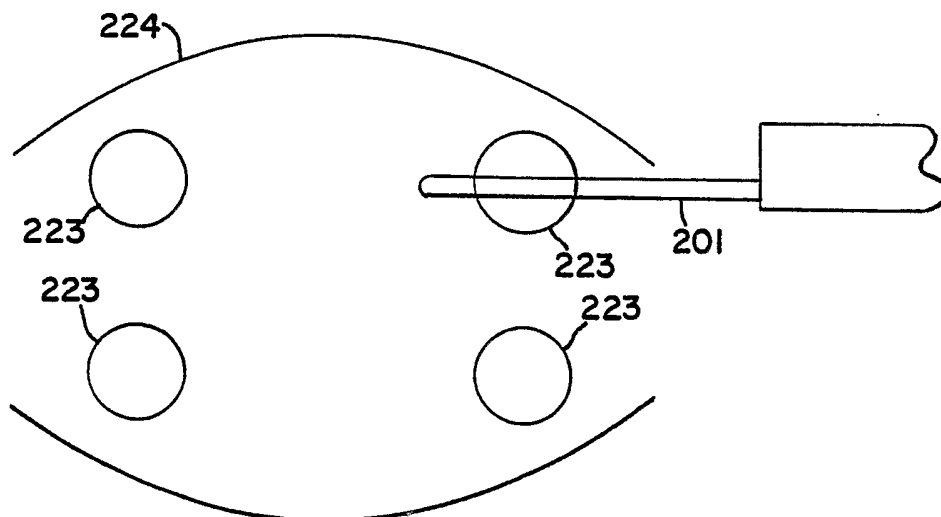

FIG. 60B

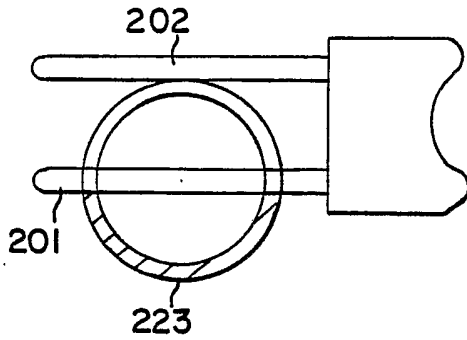

FIG. 60C

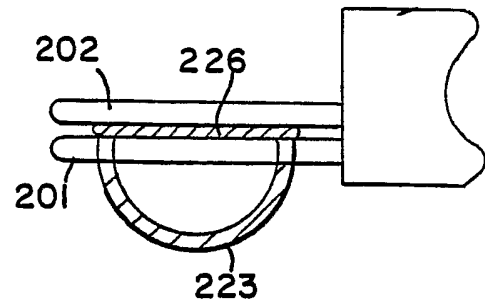

FIG. 60D

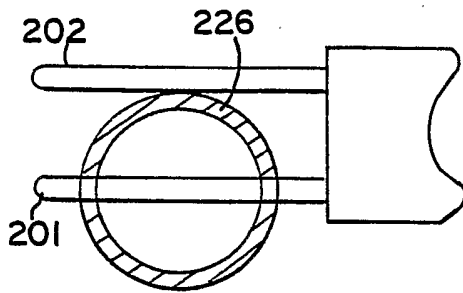

FIG. 60E

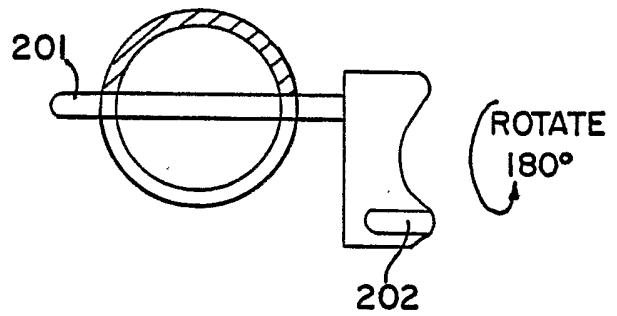

FIG. 60F

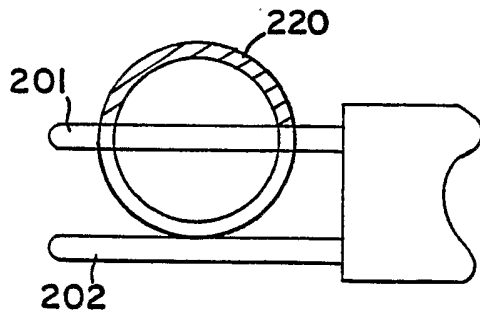

FIG. 60G

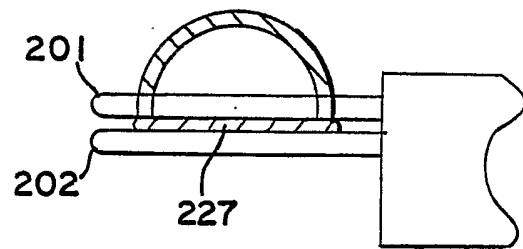

FIG. 60H

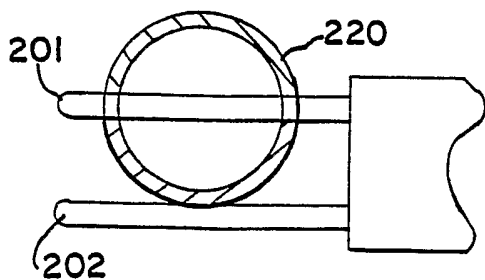
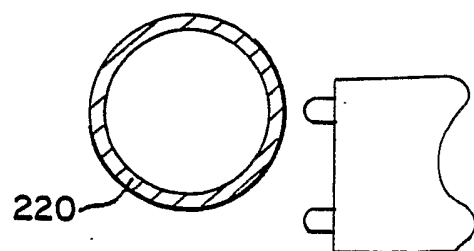

FIG. 60I



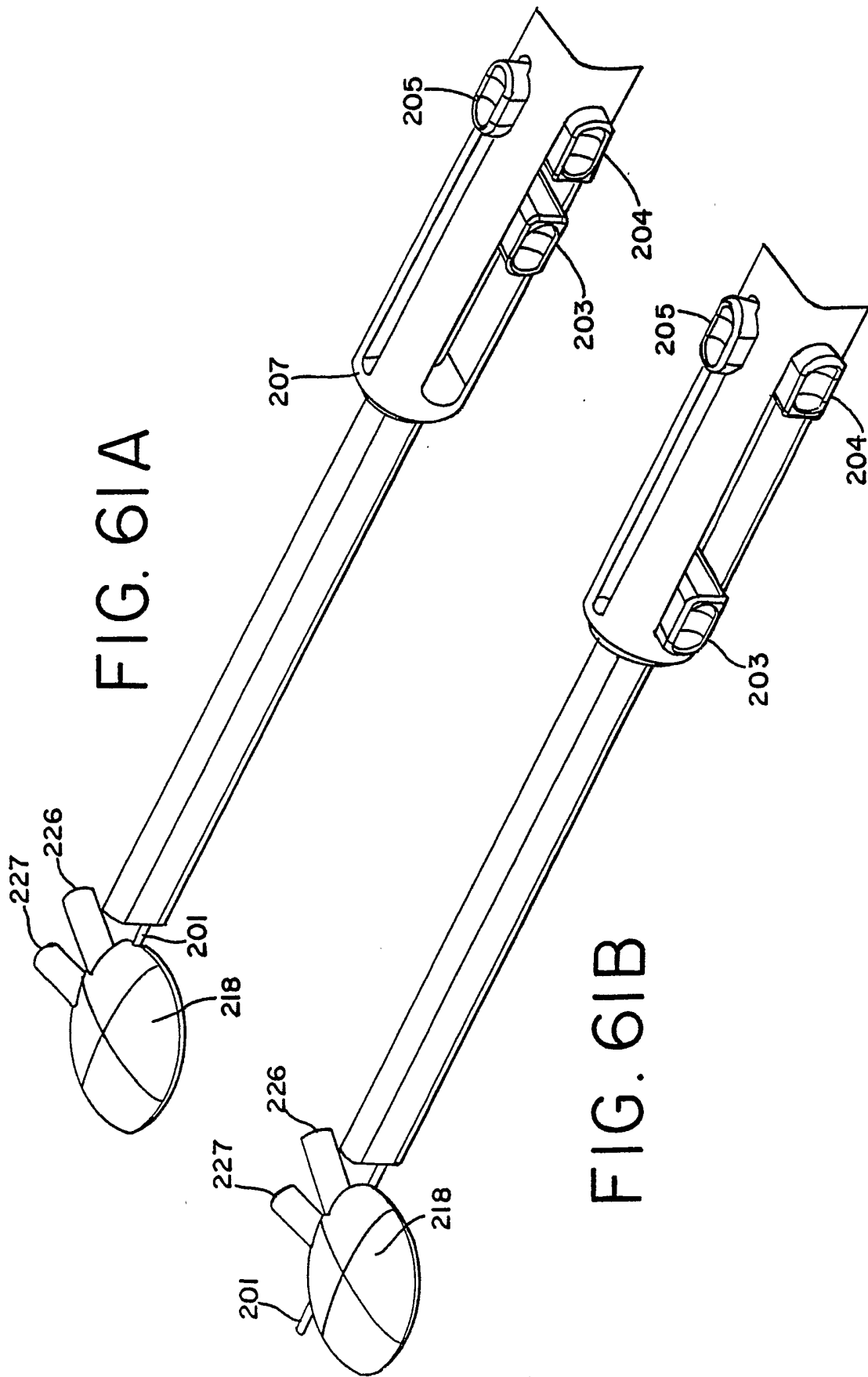
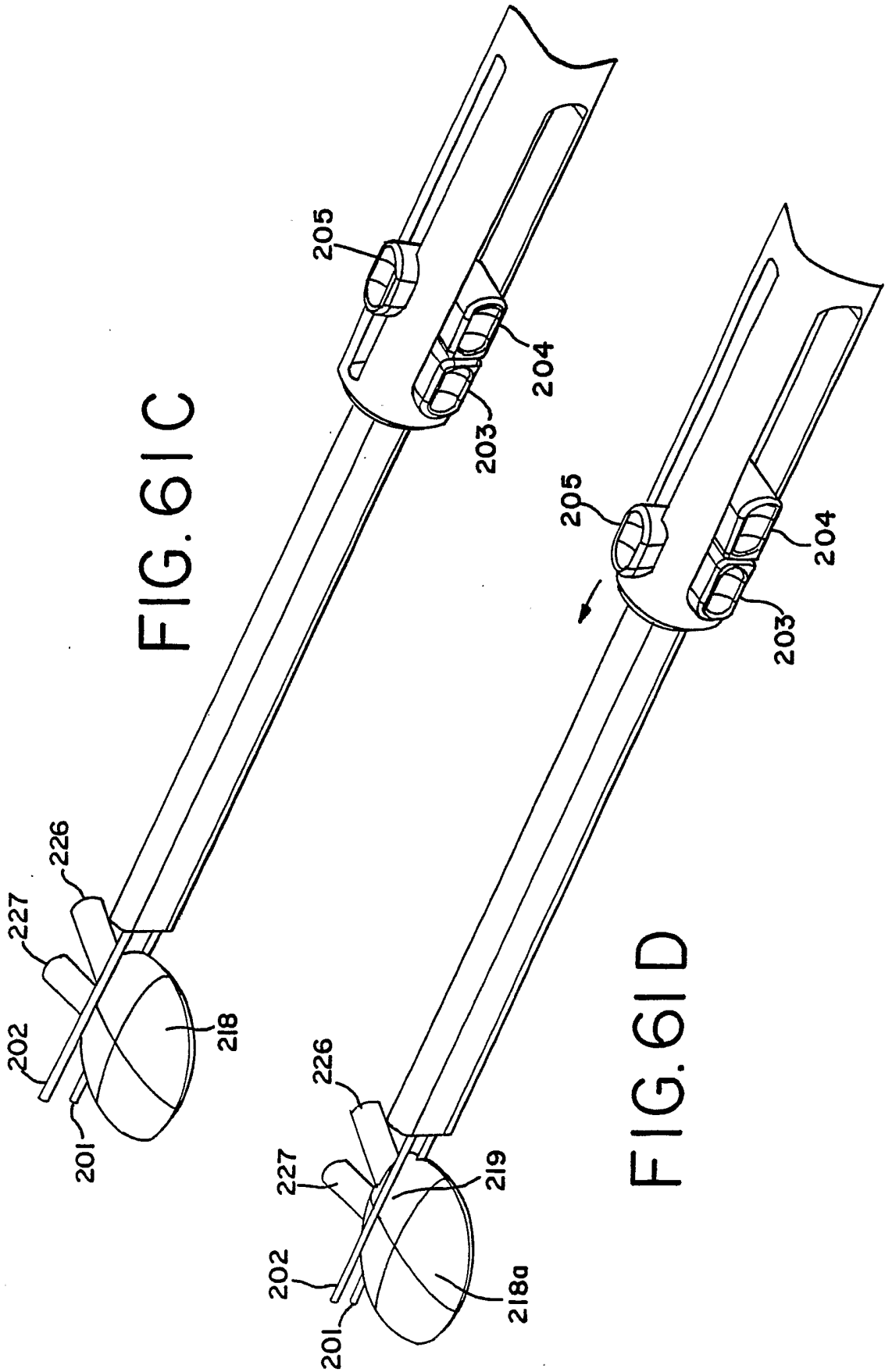

FIG. 61A

FIG. 61B



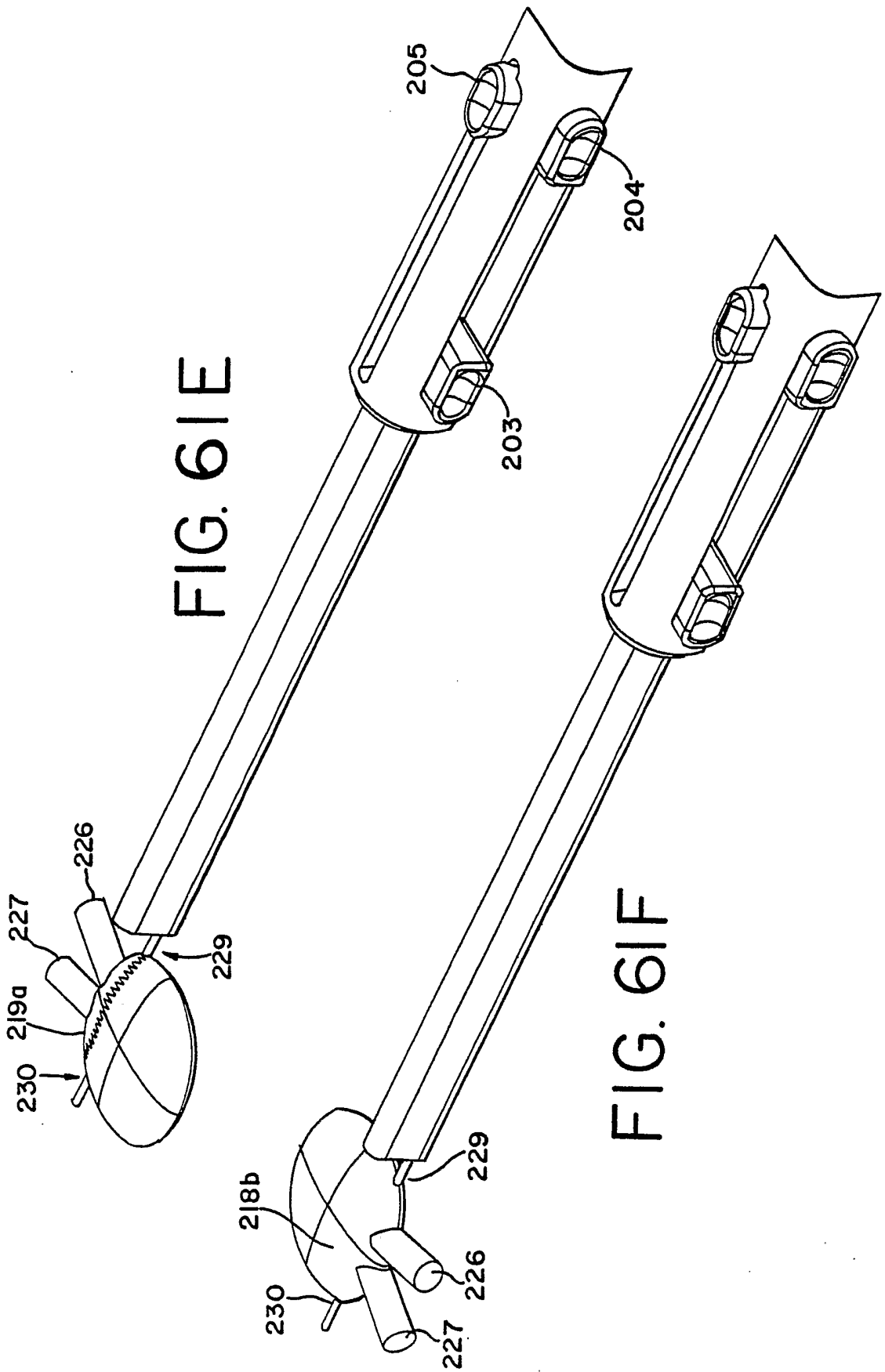

FIG. 61I

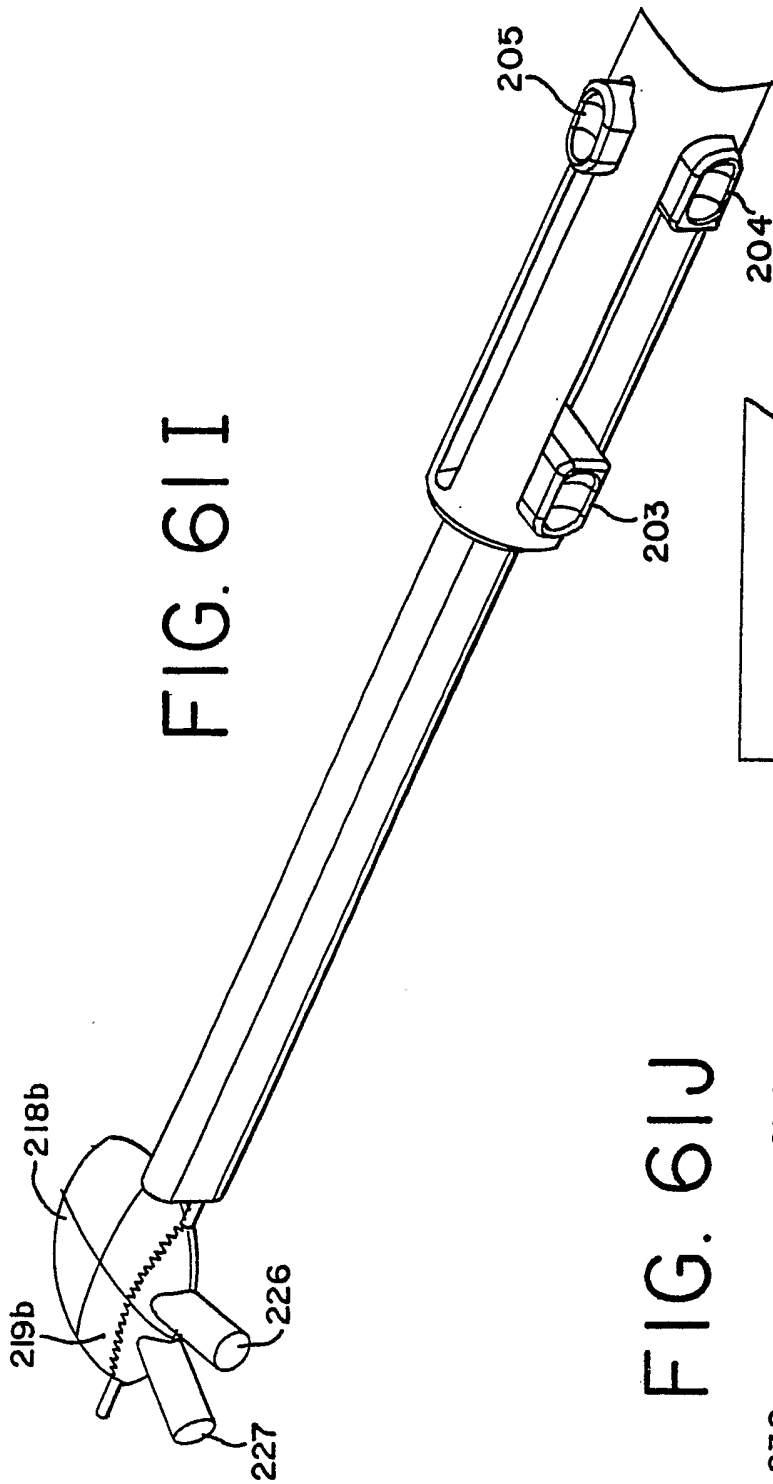

FIG. 61J

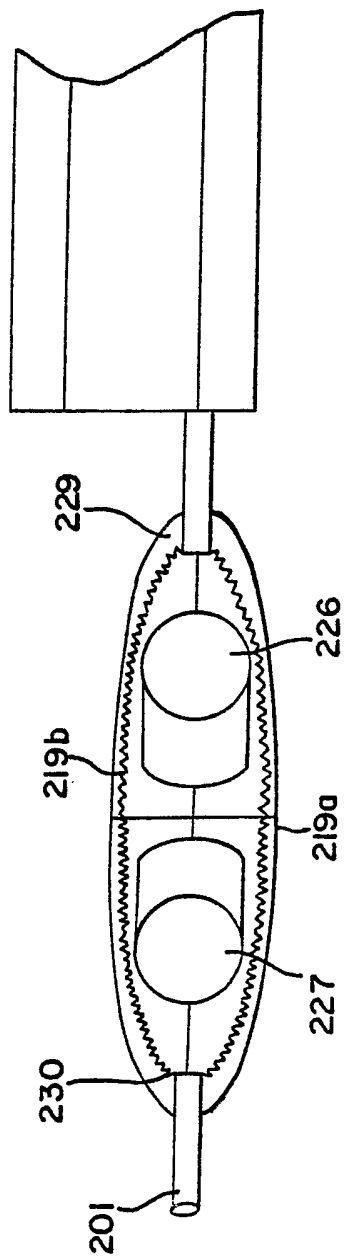

FIG.62A

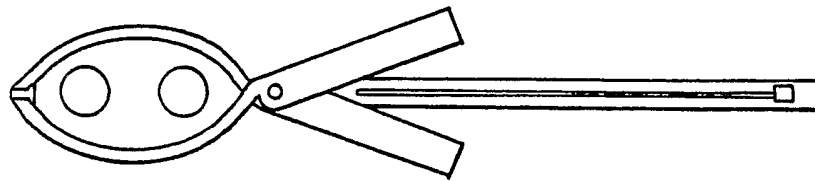

FIG.62B

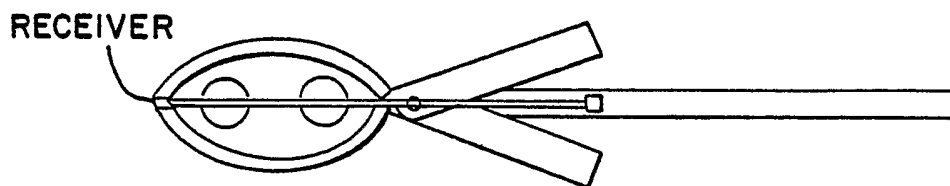

FIG.62C

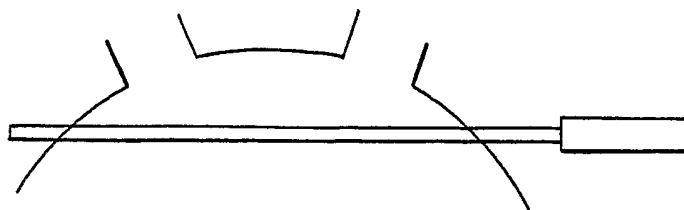

FIG. 62D

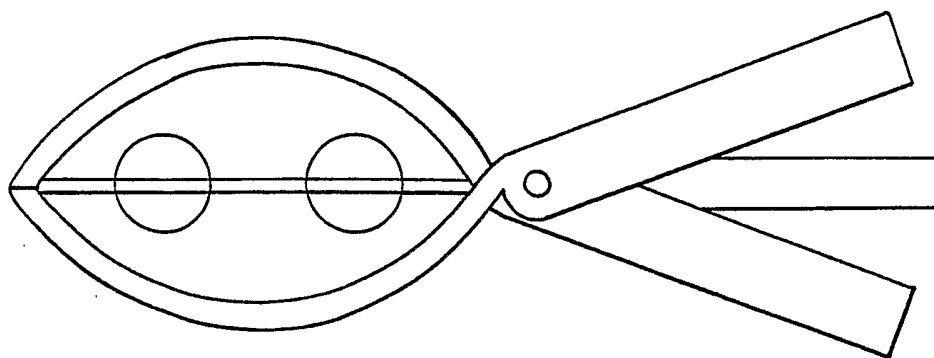

FIG. 62E

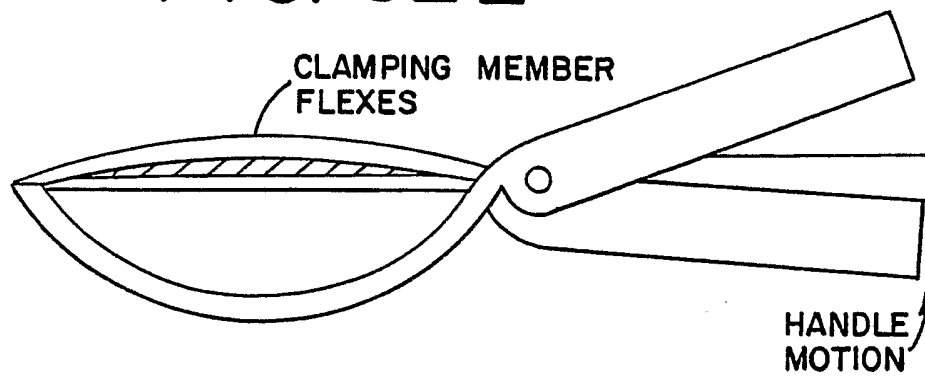

FIG. 62F

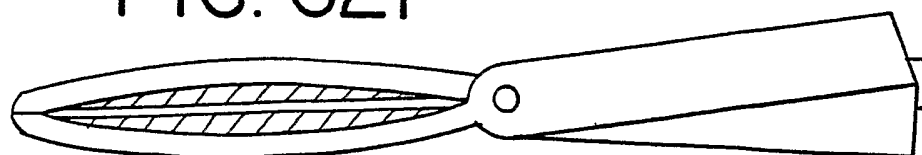

FIG. 62G

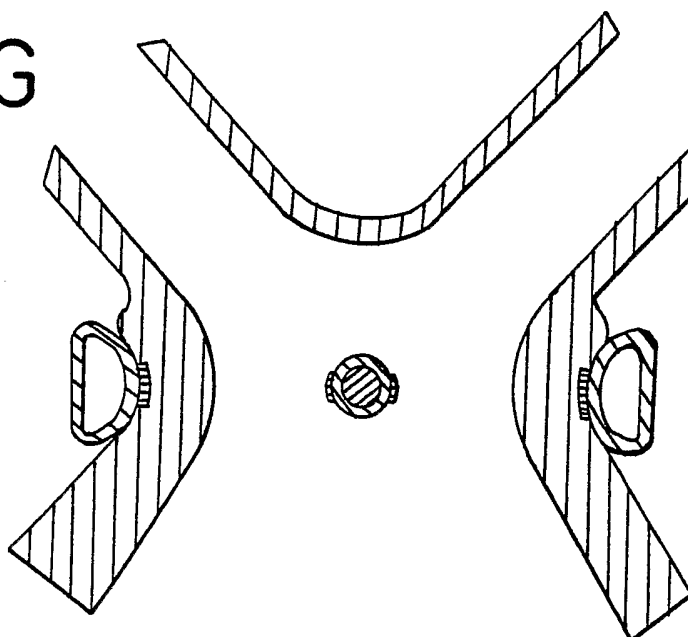

FIG. 62H

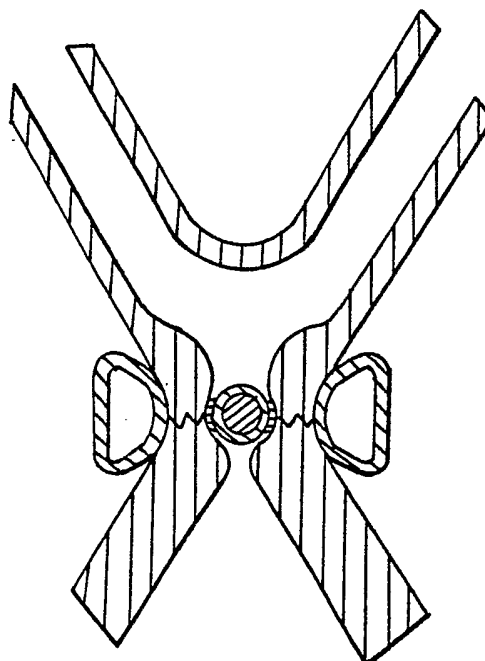
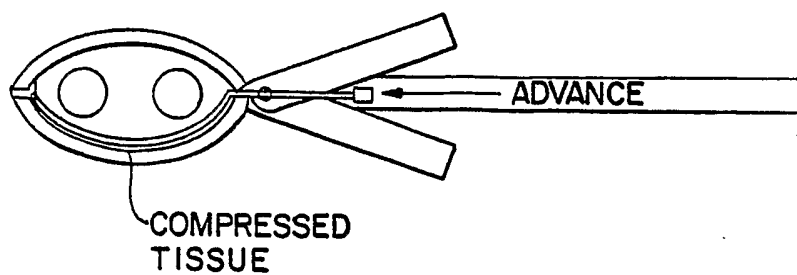

FIG. 62I



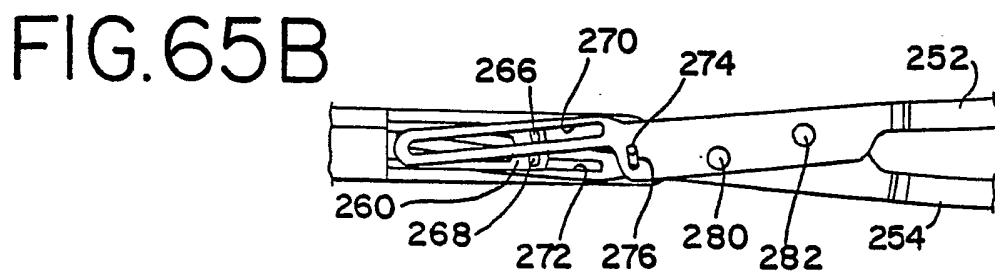
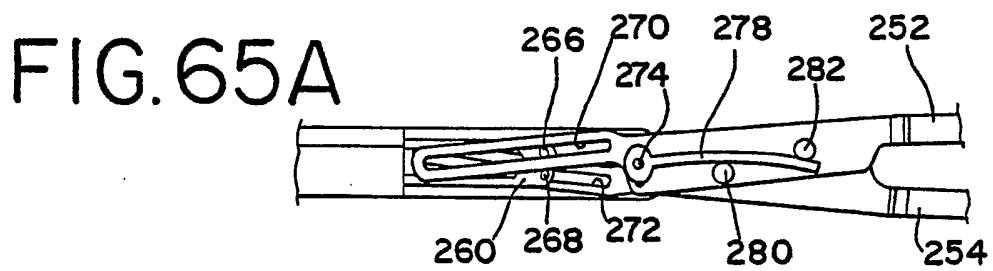
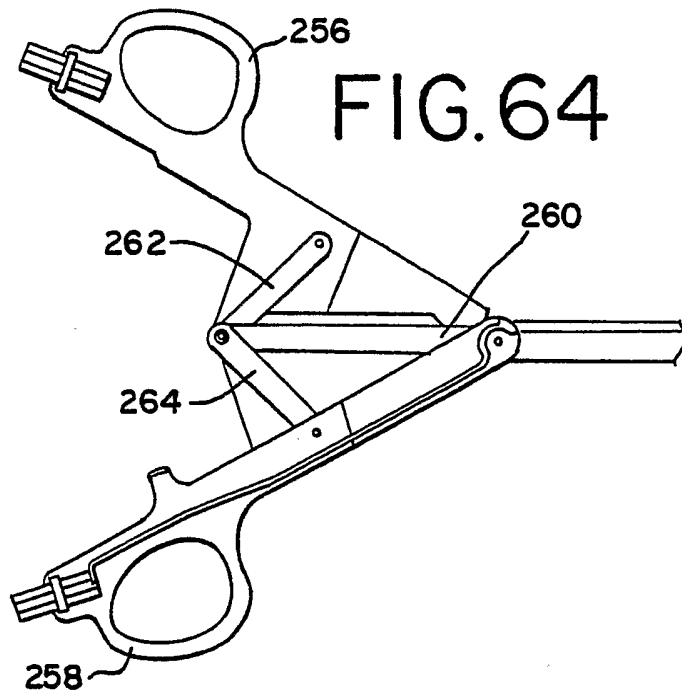
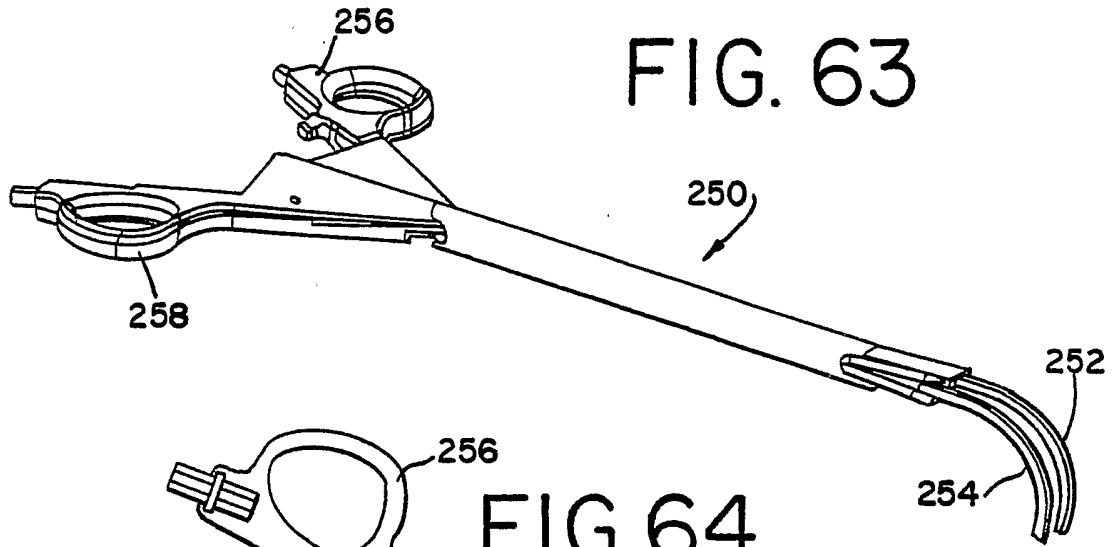

FIG. 66

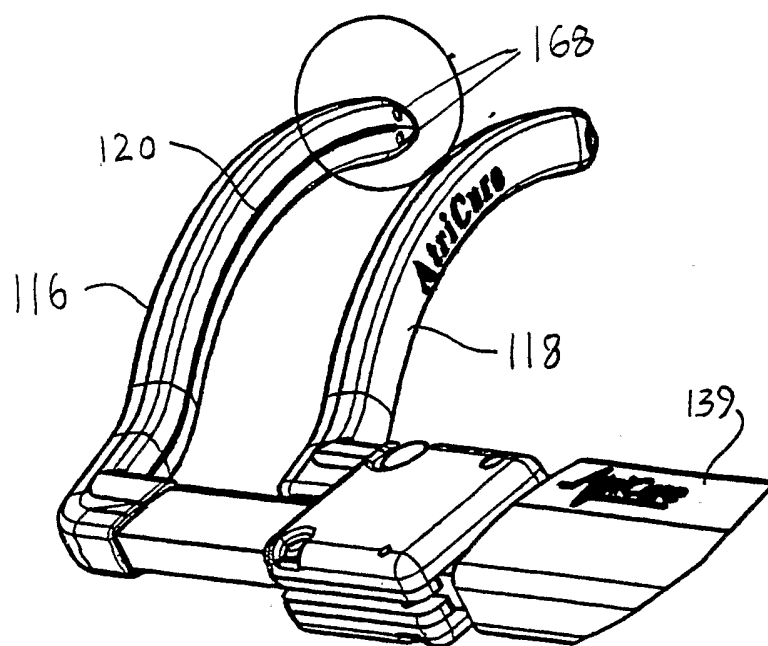

FIG. 67

