

(12) STANDARD PATENT
(19) AUSTRALIAN PATENT OFFICE

(11) Application No. **AU 2009357643 B2**

(54) Title
Toothbrush having a closed-loop arrangement of cleaning elements

(51) International Patent Classification(s)
A46B 9/04 (2006.01)

(21) Application No: **2009357643**

(22) Date of Filing: **2009.12.18**

(87) WIPO No: **WO11/084116**

(43) Publication Date: **2011.07.14**

(44) Accepted Journal Date: **2014.02.27**

(71) Applicant(s)
Colgate-Palmolive Company

(72) Inventor(s)
Jimenez, Eduardo;Rooney, Michael;Moskovich, Robert;Storz, Joachim;Klausegger, Raimund

(74) Agent / Attorney
FB Rice, L 14 90 Collins ST, Melbourne, VIC, 3000

(56) Related Art
EP 0449655 A1
US 2008/0086827 A1

(12) INTERNATIONAL APPLICATION PUBLISHED UNDER THE PATENT COOPERATION TREATY (PCT)

(19) World Intellectual Property Organization
International Bureau



(43) International Publication Date
14 July 2011 (14.07.2011)

(10) International Publication Number
WO 2011/084116 A1

(51) International Patent Classification:
A46B 9/04 (2006.01)

(74) Agent: FERNANDEZ, Amy, M.; Colgate-Palmolive Company, Patent Department, 909 River Road, Piscataway, NJ 08855 (US).

(21) International Application Number:

PCT/US2009/068647

(81) Designated States (unless otherwise indicated, for every kind of national protection available): AE, AG, AL, AM, AO, AT, AU, AZ, BA, BB, BG, BH, BR, BW, BY, BZ, CA, CH, CL, CN, CO, CR, CU, CZ, DE, DK, DM, DO, DZ, EC, EE, EG, ES, FI, GB, GD, GE, GH, GM, GT, HN, HR, HU, ID, IL, IN, IS, JP, KE, KG, KM, KN, KP, KR, KZ, LA, LC, LK, LR, LS, LT, LU, LY, MA, MD, ME, MG, MK, MN, MW, MX, MY, MZ, NA, NG, NI, NO, NZ, OM, PE, PG, PH, PL, PT, RO, RS, RU, SC, SD, SE, SG, SK, SL, SM, ST, SV, SY, TJ, TM, TN, TR, TT, TZ, UA, UG, US, UZ, VC, VN, ZA, ZM, ZW.

(22) International Filing Date:

18 December 2009 (18.12.2009)

(25) Filing Language:

English

(26) Publication Language:

English

(71) Applicant (for all designated States except US): COLGATE-PALMOLIVE COMPANY [US/US]; 300 Park Avenue, New York, NY 10022 (US).

(72) Inventors; and

(75) Inventors/Applicants (for US only): JIMENEZ, Eduardo [US/US]; 21 Manor Drive, Manalapan, NJ 07725 (US). ROONEY, Michael [US/US]; 63 Locust Avenue, Millburn, NJ 07041 (US). MOSKOVICH, Robert [US/US]; 20 Jensen Street, East Brunswick, NJ 08816 (US). STORZ, Joachim [AT/AT]; Von Gotz Weg 15-16, A-5700 Zell am See (AT). KLAUSEGGER, Raimund [AT/AT]; Museumplatz 1/5/8, A-1070 Vienna (AT).

(84) Designated States (unless otherwise indicated, for every kind of regional protection available): ARIPO (BW, GH, GM, KE, LS, MW, MZ, NA, SD, SL, SZ, TZ, UG, ZM, ZW), Eurasian (AM, AZ, BY, KG, KZ, MD, RU, TJ, TM), European (AT, BE, BG, CH, CY, CZ, DE, DK, EE, ES, FI, FR, GB, GR, HR, HU, IE, IS, IT, LT, LU, LV, MC, MK, MT, NL, NO, PL, PT, RO, SE, SI, SK, SM,

[Continued on next page]

(54) Title: TOOTHBRUSH HAVING A CLOSED-LOOP ARRANGEMENT OF CLEANING ELEMENTS

(57) Abstract: A toothbrush (100) having an arrangement of cleaning elements (130) for improved oral care and dentifrice retention. In one aspect, the invention is a toothbrush comprising a first set (140) of cleaning elements forming a loop that extends from the distal periphery of the head to the proximal periphery of the head. The loop has the shape of a racetrack and comprises a first par-elliptical wall (141) of cleaning elements at the distal periphery of the head and a second par-elliptical wall of cleaning elements located at the proximal periphery of the head. The par-elliptical walls are connected first and second arcuate rows (142, 143) of cleaning elements. In one embodiment, the first and second arcuate rows are symmetrically arranged about the longitudinal axis so that peripheral convex surfaces of the first and second arcuate rows face the longitudinal axis.



WO 2011/084116 A1

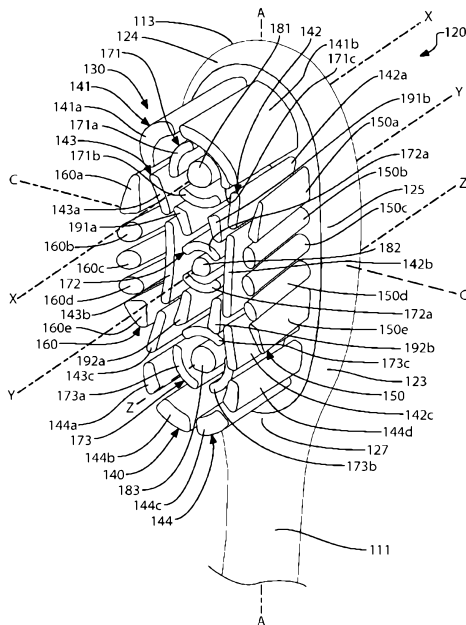

FIG. 6

WO 2011/084116 A1 

TR), OAPI (BF, BJ, CF, CG, CI, CM, GA, GN, GQ, GW, ML, MR, NE, SN, TD, TG). **Published:**

— *with international search report (Art. 21(3))*

ORAL CARE IMPLEMENT HAVING A CLOSED-LOOP ARRANGEMENT OF CLEANING ELEMENTS

5

Technical Field

[0001] The present invention relates generally to ansate oral care implements, and specifically to toothbrushes, either manual or powered, that have a handle and a head having cleaning elements for oral cleaning.

10

Background

[0002] A toothbrush is used to clean the teeth by removing plaque and debris from the tooth surfaces. Conventional toothbrushes provided with a flat bristle trim are limited in their ability to conform to the curvature of the teeth, to penetrate into the interproximal areas between the teeth, to sweep away the plaque and debris, and to
15 clean along the gum line. Additionally, such toothbrushes have a limited ability to retain dentifrice for cleaning the teeth. During the brushing process, the dentifrice typically slips through the tufts of bristles and away from the contact between the bristles and the teeth. As a result, the dentifrice is often spread around the mouth, rather than being concentrated on the contact of the bristles with the teeth. Therefore,
20 the efficiency of the cleaning process is reduced.

[0003] While substantial efforts have been made to modify the cleaning elements of toothbrushes to improve the efficiency of the oral cleaning process and to hold the dentifrice in place during brushing, the industry continues to pursue arrangements of cleaning elements that will improve upon the preceding technology.

25

[0004] In an early attempt at improving the cleaning elements, toothbrushes were developed having two or three circular brush sections which are arranged within holders that may be screwed into mating receptacles in the tooth brush handle so that they can be removed and replaced as needed. Each brush section contains stiff cleaning elements and is spaced from the other along the longitudinal axis of the handle at a
30 distance less than the thickness of a tooth so that the brush operates on both the lingual (inside) and facial (outside) surfaces of the teeth.

30

35

[0005] Another existing toothbrush includes a head containing a flexible, rubber-like prophylaxis polishing cup or "prophy cup" similar to that used by dental personnel to professionally clean teeth. This prophy cup is loaded with toothpaste by the user and applied to the teeth. The "soft rubber-like prophy cup device follows the contours of
35 teeth more effectively than bristles." A ring of cleaning elements ("bristle tufts") are

placed about the periphery of the toothbrush head which co-act with the prophy cups to clean the user's teeth and gums.

5 [0006] More recently, the strategic arrangement and combination of cleaning elements in the form of elastomeric prophy cups and bristle tufts has become more common as a way of improving cleaning efficiency and maintaining the dentifrice in place during brushing. One example of the combined use and strategic arrangement of elastomeric prophy cups and bristle tufts is a toothbrush having a head portion comprising a plurality of inner loops formed by elastomeric walls. The central inner loop is surrounded by outer loops formed of bristles. A central cleaning element, 10 formed as a bristle tuft, is located within the elastomeric inner loop.

[0007] Another example of the combined use and strategic arrangement of elastomeric prophy cups and bristle tufts can be found in a toothbrush having a head portion comprising a plurality of soft elastomer prophy cups surrounded by bristle rings. In another embodiment, a toothbrush exists wherein the centralized prophy cups 15 are formed by groups of densely packed cleaning elements that are surrounded by bristle rings. The bristle rings in this toothbrush are also disclosed as having one or more tufts at an inclination.

[0007a] Any discussion of documents, acts, materials, devices, articles or the like which has been included in the present specification is not to be taken as an admission 20 that any or all of these matters form part of the prior art base or were common general knowledge in the field relevant to the present disclosure as it existed before the priority date of each claim of this application.

[0007b] Throughout this specification the word "comprise", or variations such as "comprises" or "comprising", will be understood to imply the inclusion of a stated 25 element, integer or step, or group of elements, integers or steps, but not the exclusion of any other element, integer or step, or group of elements, integers or steps.

Summary

[0008] A toothbrush is provided comprising: a handle: a head connected to the 30 handle, the head having a proximal periphery, a distal periphery, a first surface, a longitudinal axis and a lateral axis; a first set of cleaning elements forming a loop that extends from the distal periphery of the head to the proximal periphery of the head, the first set of cleaning elements comprising: a first par-elliptical wall of cleaning elements located at the distal periphery of the head, the first par-elliptical wall terminating in a 35 first end and a second end; a second par-elliptical wall of cleaning elements located at the proximal periphery of the head, the second par-elliptical wall terminating in a first

end and a second end; a first row of cleaning elements extending from the first end of the first par-elliptical wall to the first end of the second par-elliptical wall; and a second row of cleaning elements extending from the second end of the first par-elliptical wall to the second end of the second par-elliptical wall; wherein the first and second rows are symmetrically arranged about the longitudinal axis and the lateral axis, the first and second rows separated by a first distance that increases with distance from the lateral axis; a third row of cleaning elements extending adjacent to the first row and located along a first lateral periphery of the head, the third row located outside of the loop, the third row extending upward from the first surface at an incline so as to diverge from the first row, the third row having a height that is greater than a height of the first row; and a fourth row of cleaning elements extending adjacent to the second row and located along a second lateral periphery of the head, the fourth row located outside of the loop, the fourth row extending upward from the first surface at an incline so as to diverge from the second row, the fourth row having a height that is greater than a height of the second row.

[0009] A further toothbrush is provided comprising: a handle; a head connected to the handle, the head having a proximal periphery, a distal periphery, a first surface and a longitudinal axis; a first set of cleaning elements forming a loop that extends from the distal periphery of the head to the proximal periphery of the head, the first set of cleaning elements comprising: a first par-elliptical wall of cleaning elements located at the distal periphery of the head, the first par-elliptical wall terminating in a first end and a second end; a second par-elliptical wall of cleaning elements located at the proximal periphery of the head, the second par-elliptical wall terminating in a first end and a second end; a first row of cleaning elements extending from the first end of the first par-elliptical wall to the first end of the second par-elliptical wall; and a second row of cleaning elements extending from the second end of the first par-elliptical wall to the second end of the second par-elliptical wall; a third row of cleaning elements extending adjacent to the first row and located along a first lateral periphery of the head, the third row located outside of the loop, the third row extending upward from the first surface at an incline so as to diverge from the first row, the third row having a height that is greater than a height of the first row; and a fourth row of cleaning elements extending adjacent to the second row and located along a second lateral periphery of the head, the fourth row located outside of the loop, the fourth row extending upward from the first surface at an incline so as to diverge from the second row, the fourth row having a height that is greater than a height of the second row.

[0010] A still further toothbrush is provided comprising: a handle: a head connected to the handle, the head having a proximal periphery, a distal periphery, a first surface and a longitudinal axis; a first set of cleaning elements forming a loop that extends from the distal periphery of the head to the proximal periphery of the head, the first set of cleaning elements comprising: a first par-elliptical wall of cleaning elements located at the distal periphery of the head, the first par-elliptical wall terminating in a first end and a second end; a second par-elliptical wall of cleaning elements located at the proximal periphery of the head, the second par-elliptical wall terminating in a first end and a second end; a first arcuate row of cleaning elements extending from the first end of the first par-elliptical wall to the first end of the second par-elliptical wall; and a second arcuate row of cleaning elements extending from the second end of the first par-elliptical wall to the second end of the second par-elliptical wall; and wherein the first and second arcuate rows are symmetrically arranged about the longitudinal axis so that peripheral convex surfaces of the first and second arcuate rows face the longitudinal axis.

[0011] A still yet further toothbrush is provided comprising: a handle: a head connected to the handle, the head having a proximal periphery, a distal periphery, a first surface and a longitudinal axis; a first set of cleaning elements forming a loop that extends from the distal periphery of the head to the proximal periphery of the head, the first set of cleaning elements comprising: a first par-elliptical wall of cleaning elements located at the distal periphery of the head, the first par-elliptical wall terminating in a first end and a second end; a second par-elliptical wall of cleaning elements located at the proximal periphery of the head, the second par-elliptical wall terminating in a first end and a second end; a first row of cleaning elements extending from the first end of the first par-elliptical wall to the first end of the second par-elliptical wall; and a second row of cleaning elements extending from the second end of the first par-elliptical wall to the second end of the second par-elliptical wall; wherein a top surface of the loop has a longitudinal side profile that is a stretched out S-shape; and wherein the first and second rows are first and second arcuate rows symmetrically arranged about the longitudinal axis and a lateral axis of the head, the first and second arcuate rows separated by a first distance that increases with distance from the lateral axis.

[0012] A further toothbrush is provided comprising: a handle: a head connected to the handle, the head having a proximal periphery, a distal periphery, a first surface and a longitudinal axis; a first set of cleaning elements forming a loop that extends from the distal periphery of the head to the proximal periphery of the head; and wherein a top surface of the loop has a longitudinal side profile comprising a concave section that

extends from a peak at a distal-most point of the loop to a transition point at a middle-portion of the loop, and a convex section that extends from the transition point to a proximal-most point of the second par-elliptical wall.

5

Brief Description of the Drawings

[0013] This invention is capable of use in a broad array of oral care implements and hygiene products. The drawings illustrate one use of the invention and are not to be construed as the only embodiment of the invention.

10

[0014] Figure 1 is a perspective view a toothbrush according to one embodiment of the present invention.

[0015] Figure 2 is a front view of the toothbrush of Figure 1.

[0016] Figure 3 is a left-side view the toothbrush of Figure 1.

[0017] Figure 4 is a right-side view the toothbrush of Figure 1.

[0018] Figure 5 is a top view of the toothbrush of Figure 1.

15

[0019] Figure 6 is a close-up perspective view of the head of the toothbrush of Figure 1.

[0020] Figure 7 is a close-up front view of the head of the toothbrush of Figure 1.

[0021] Figure 8 is a cross-sectional view of the head of the toothbrush of Figure 1 along view VIII-VIII of Figure 7.

20

[0022] Figure 9 is a cross-sectional view of the head of the toothbrush of Figure 1 along view IX-IX of Figure 7.

[0023] Figure 10 is a left-side view of the toothbrush of Figure 1 wherein certain cleaning elements have been removed to clearly show a lateral side profile of the substantially closed-loop formed by the first set of cleaning elements.

25

Detailed Description of the Drawings

[0024] In the following description, the invention is discussed in terms of a manual toothbrush incorporating the subject arrangement of cleaning elements. However, in other forms, the invention could be in the form of other oral care implements including a soft-tissue cleansing implement, a powered toothbrush, or other ansate implement designed for oral care.

30

[0025] Referring first to Figures 1-5 concurrently, a toothbrush 100 is illustrated according to one embodiment of the present invention. The toothbrush 100 generally comprises a handle 110 and a head 120. The handle 110 provides the user with a mechanism by which he/she can readily grip and manipulate the toothbrush 100. The handle 110 is generically illustrated and may be formed of many different shapes, sizes,

35

materials and a variety of manufacturing methods that are well-known to those skilled in the art. If desired, the handle 110 may include a suitable textured grip (not shown) made of elastomeric material or can be a multi-part construction. Stated simply, the details of the handle 110 are not limiting of the present invention and, thus, require no further discussion for purposes of the present invention.

[0026] The toothbrush 100 extends from a proximal end 112 to a distal end 113 along a longitudinal axis A-A (illustrated in FIG. 2). The head 120 is operably connected to the handle 110. The head 120 and handle 110 of the toothbrush are preferably formed as a single unitary structure using a molding, milling, machining or other suitable process. However, in other embodiments, the handle 110 and head 120 may be formed as separate components which are operably connected at a later stage of the manufacturing process by any suitable technique known in the art, including without limitation thermal welding, a tight-fit assembly, a coupling sleeve, adhesion, or fasteners. Whether the head 120 and handle 110 are of a unitary or multi-piece construction (including connection techniques) is not limiting of the present invention.

[0027] It should be noted at this time that relative terms such as distal, middle, proximal, upper, lower, top, bottom, left, right etc. are merely used to delineate relative positions of the components of the toothbrush 100 with respect to one another and are not intended to be in any further way limiting of the present invention.

[0028] The head 120 generally comprises a front surface 121 and a rear surface 122. The front surface 121 and the rear surface 122 of the head 120 can take on a wide variety of

shapes and contours, none of which are limiting of the present invention. For example, the front and rear surfaces **121**, **122** can be planar, contoured or combinations thereof. Moreover, if desired, the rear surface **122** may also comprise additional structures for oral cleaning, such as a soft tissue cleanser. An example of a suitable soft tissue cleanser is disclosed in U.S. Patent 7,143,462, issued December 5, 2006 to the assignee of the present application, the entirety of which is hereby incorporated by reference.

Furthermore, while the head **120** is normally widened relative to the neck **111** of the handle **110**, it could in some constructions simply be a continuous extension or narrowing of the handle **110**.

[0029] The head **120** also comprises a distal periphery **124**, a first lateral periphery **125**, a second later periphery **126**, and a proximal periphery **127**. The distal periphery **124**, the first lateral periphery **125** and the second later periphery **126** are bound by a peripheral side surface **123** of the head **120**. The proximal periphery **127** is defined where the head **120** transitions into the neck **111**.

[0030] A collection **130** of cleaning elements are provided on the front surface of the head **120** for cleaning contact with an oral surface, preferably teeth. While the collection **130** of cleaning elements is particularly suited for brushing teeth, the collection **130** of cleaning elements can also be used to clean oral soft tissue, such as a tongue, gums, or cheeks instead of or in addition to teeth. As used herein, the term "cleaning element" is used in a generic sense to refer to any structure that can be used to clean or massage an oral surface through relative surface contact. Common examples of "cleaning elements" include, without limitation, filament bristles, fiber bristles, nylon bristles, spiral bristles, rubber bristles, elastomeric protrusions, flexible polymer protrusions, co-extruded filaments, flag bristles, crimped bristles, anti-bacterial bristles and combinations thereof and/or structures containing such materials or combinations.

[0031] The collection **130** of cleaning elements of the present invention can be connected to the head **120** in any manner known in the art. For example, anchor free tufting (AFT) could be used to mount the cleaning elements. In AFT, a plate or membrane is secured to the brush head such as by ultrasonic welding. The bristles (or other elastomeric elements) extend through the plate or membrane. The free ends of the bristles on one side of the plate or membrane perform the cleaning function. The ends of the bristles on the

other side of the plate or membrane are melted together by heat to be anchored in place. Any suitable form of cleaning elements may be used in the broad practice of this invention. Alternatively, the bristles could be mounted to tuft blocks or sections by extending through suitable openings in the tuft blocks so that the base of the bristles is mounted within or below the tuft block.

[0032] Referring now to FIGS. 6 and 7 concurrently, the details of the head **120** and the collection **130** of cleaning elements extending therefrom will be described in accordance with an embodiment of the present invention. The head **120** of the toothbrush comprises a longitudinal axis **A-A** and a lateral axis **C-C**. Generally, the collection **130** of cleaning elements comprises a first set **140** of cleaning elements, a second set **150** of cleaning elements, a third set **160** of cleaning elements, and a plurality of prophylaxis cups **171-173**.

[0033] The first set **140** of cleaning elements generally comprises a distal par-elliptical wall **141** of cleaning elements, two arcuate rows **142-143** of cleaning elements, and a proximal par-elliptical wall **144**. The distal par-elliptical wall **141** is formed by the cleaning elements **141a-b**. The proximal par-elliptical wall **144** is formed by the cleaning elements **144a-d**. The first arcuate row **142** is formed by cleaning elements **142a-c** while the second arcuate row **143** is formed by cleaning elements **143a-c**.

[0034] The second set **150** of cleaning elements are arranged in a row along the lateral periphery **125** of the head **120**. Similarly, the third set **160** of cleaning elements are arranged in a row along the lateral periphery **126** of the head **120**. Specifically, the row formed by the first set **150** of cleaning elements comprises cleaning elements **150a-e** while the row formed by the second set **160** of cleaning elements comprises cleaning elements **160a-e**.

[0035] Preferably, all of the cleaning elements of the distal par-elliptical wall **141**, the two arcuate rows **142-143**, and the proximal par-elliptical wall **144** are formed by densely packed bristles. However, the invention is not so limited and one, a few, or all of these cleaning elements can be formed of another material, such as an elastomer, etc.

Moreover, while the distal par-elliptical wall **141**, the two arcuate rows **142-143**, and the proximal par-elliptical wall **144** are illustrated as being formed by two, three and four cleaning elements respectively, each of the distal par-elliptical wall **141**, the two arcuate

rows **142-143**, and the proximal par-elliptical wall **144** can be formed by more or less cleaning elements than the illustrated embodiment. Moreover, it is even possible that the distal par-elliptical wall **141**, the two arcuate rows **142-143**, and the proximal par-elliptical wall **144** be formed as a single cleaning element wall.

[0036] The prophylaxis cup **171** is formed by three arcuate elastomeric wall sections **171a-c**. Similarly, the prophylaxis cup **173** is formed by three arcuate elastomeric wall sections **172a-c**. The central prophylaxis cup **172** is formed by two arcuate elastomeric wall sections **172a-b**. Of course, each of the prophylaxis cups **171-173** can be constructed by more or less sections than the illustrated embodiment and can be constructed of other materials, such as densely packed bristles. Suitable elastomeric materials include any biocompatible resilient material suitable for uses in an oral hygiene apparatus. To provide optimum comfort as well as cleaning benefits, the elastomeric material preferably has a hardness property in the range of A10 to A40 Shore hardness, and preferably A25 Shore hardness. One preferred elastomeric material is styrene-ethylene/butylene-styrene block copolymer (SEBS) manufactured by GLS Corporation. Nevertheless, SEBS material from other manufacturers or other materials within and outside the noted hardness range could be used.

[0037] All of the prophylaxis cups **171-173** are arranged within a loop, which is preferably a substantially closed loop, formed by the first set of cleaning elements **140** (which will be discussed in greater detail below). The prophylaxis cups **171-173** are also arranged along the longitudinal axis **A-A** of the head. The prophylaxis cup **172** is also located on the lateral axis **C-C** of the head **120**.

[0038] In further relation to the first set of cleaning elements **140**, the prophylaxis cup **171** is located within the distal par-elliptical wall **141** and the prophylaxis cup **173** is located within the proximal par-elliptical wall **144**. The prophylaxis cup **172** is centrally located between the two arcuate rows **142-143**.

[0039] An elongated central cleaning element **181-183** is located within each of the prophylaxis cups **171-173** and extends upward from the first surface **121** of the head **120** in a substantially normal manner. Specifically, the central cleaning element **181** is located within the prophylaxis cup **171** and extends along a central axis **X-X** of the prophylaxis cup **171**. The central cleaning element **182** is located within the prophylaxis

cup **172** and extends along a central axis **Y-Y** of the prophylaxis cup **172**. The central cleaning element **183** is located within the prophylaxis cup **173** and extends along a central axis **Z-Z** of the prophylaxis cup **173**. Each of the elongated cleaning elements **181-183** is preferably taller than its respective prophylaxis cup **171-173** and extends above its top surface. Each of the elongated central cleaning elements **181-183** terminate in a cleaning end that is preferably a cone-like tip. Of course, the invention is not so limited and the cleaning ends of the central cleaning elements **181-183** can take on other shapes. The central cleaning elements **181-183** are preferably densely packed bristle tufts but can be elastomeric fingers if desired. In some embodiments of the invention, the elongated cleaning elements **181-183** may be omitted all together.

[0040] A first pair of elongated cleaning elements **191a-b** is also located within the substantially closed loop formed by the first set **140** of cleaning elements. The first pair of elongated cleaning elements **191a-b** is located between the first prophylaxis cup **171** and the second prophylaxis cup **172**. Similarly, a second pair of elongated cleaning elements **192a-b** is located within the substantially closed loop formed by the first set **140** of cleaning elements. The second pair of elongated cleaning elements **192a-b** is located between the second prophylaxis cup **172** and the second prophylaxis cup **173**.

[0041] Referring solely now to FIG. 7, the details of the front profile of the first set **140** of cleaning elements will be discussed. Collectively, the distal par-elliptical wall **141** of cleaning elements, the two arcuate rows **142-143** of cleaning elements, and the proximal par-elliptical wall **144** form a substantially closed-loop that extends from the distal periphery **124** of the head **120** to the proximal periphery **127** of the head **120**. The substantially closed-loop formed by the distal par-elliptical wall **141** of cleaning elements, the two arcuate rows **142-143** of cleaning elements, and the proximal par-elliptical wall **144** is also symmetrically located along the longitudinal axis **A-A** of the head **120**. As best visible in FIG. 7, the substantially closed-loop resembles a racetrack in shape. Of course, other shapes can be utilized in certain alternative embodiments.

[0042] The distal par-elliptical wall **141** circumferentially extends from a first end **241a** to a second end **241b**. The distal par-elliptical wall **141** circumferentially extends at least 180 degrees, and in the illustrated embodiment extends about 180 degrees. The proximal par-elliptical wall **144** circumferentially extends from a first end **244a** to a second end

244b. The proximal par-elliptical wall **144** circumferentially extends at least 180 degrees, and in the illustrated embodiment extends about 180 degrees.

[0043] The first arcuate row **142** extends from the first end **241a** of the distal par-elliptical wall **141** to the first end **244a** of the proximal par-elliptical wall **144**. Similarly, the second arcuate row **143** extends from the second end **241b** of the distal par-elliptical wall **141** to the second end **244a** of the proximal par-elliptical wall **144**. The first and second arcuate rows **142**, **143** are arranged on the head **120** so as to be symmetrically located about both the longitudinal axis **A-A** and the lateral axis **C-C** of the head. The first and second arcuate rows **142**, **143** are separated by a distance **D** that increases with distance from the lateral axis **C-C**. The arcuate rows **142**, **143** are arranged so that their convex peripheral surfaces oppose one another.

[0044] Referring now to FIGS. 7-9 concurrently, the details of the second and third sets **150**, **160** of cleaning elements will be discussed, along with their relationship to the first set **140** of cleaning elements and the head **120**. As mentioned above, the third and second sets **150**, **160** of cleaning elements are arranged in rows along the first and second lateral peripheries **125**, **126** of the head **120** respectively. The cleaning elements **160a-e** extend from the first surface **121** of the head **120** at a non-normal angle Θ so that the cleaning elements **160a-e** extend from the first surface **121** of the head **120** so as to diverge from the second row **143** of cleaning elements (which preferably extend from the first surface **121** at a substantially normal angle). Similarly, the cleaning elements **150a-e** extend from the first surface **121** of the head **120** at a non-normal angle Θ so that the cleaning elements **150a-e** extend from the first surface **121** of the head **120** so as to diverge from the first row **142** of cleaning elements (which preferably extend from the first surface **121** at a substantially normal angle). Preferably, the angle Θ is in the range of 1 to 15 degrees, and most preferably 4 degrees.

[0045] A longitudinal channel **165** is formed between the third set **160** of cleaning elements **160a-e** and the third row **143** of cleaning elements **143a-c**. Similarly, a longitudinal channel **155** is formed between the second set **150** of cleaning elements **150a-e** and the second row **142** of cleaning elements **142a-c**. The longitudinal channels **155**, **165** provides a cavity for receiving and retaining dentifrice during oral care.

[0046] The cleaning elements **160a-e** of the third set **160** terminate in cleaning ends **161a-e**. The cleaning ends **161a-e** are preferably tapered so as to form a longitudinal edge **162** along the row formed by the third set **160** of cleaning elements **160a-e**. Similarly, the cleaning elements **150a-e** of the second set **150** terminate in cleaning ends **151a-e**. The cleaning ends **151a-e** are preferably tapered so as to form a second longitudinal edge **152** along the row formed by the third set **150** of cleaning elements **150a-e**. The tapered and inclined nature of the second and third rows **150, 160** of cleaning elements **150a-e, 160a-e** not only affords increased cleaning of the teeth along the gum line during brushing but also provides a means by which to direct dentifrice into those areas.

[0047] As best visible in FIG. 9, the second and third sets **150, 160** of cleaning elements **150a-e, 160a-e** are taller than the second and third rows **142, 143** of cleaning elements **142-c, 143a-c** respectively. Stated another way, the second and third sets **150, 160** of cleaning elements **150a-e, 160a-e** have a height that is greater than the height of the second and third rows **142, 143** of cleaning elements **142-c, 143a-c** respectively. As used herein, a height is the normal distance from the first surface **121** of the head **120** to the uppermost portion of the subject element.

[0048] Referring now to FIGS. 7 and 9 concurrently, as discussed above, the prophylaxis cup **171** is located within the distal par-elliptical wall **141** and the prophylaxis cup **173** is located within the proximal par-elliptical wall **144**. As a result an annular channel **195** exists between the prophylaxis cup **171** and the distal par-elliptical wall **141**. Similarly, an annular channel **196** exists between the prophylaxis cup **173** and the proximal par-elliptical wall **144**. These annular channels **195, 196** provide cavities for receiving and further retaining dentifrice during oral care.

[0049] As can be seen in FIG. 9, the distal-most portion of the first par-elliptical wall **141** extends upward from the first surface **121** of the head **120** in an inclined manner at an angle β away from the handle **110**. Preferably, the angle β is in the range of 1 to 15 degrees, and most preferably 4 degrees. Conversely, the proximal-most portion of the second par-elliptical wall **144** extends upward from the first surface **121** of the head **120** in an inclined manner at an angle Φ toward the handle **110**. Preferably, the angle Φ is in the range of 1 to 15 degrees, and most preferably 4 degrees.

[0050] Referring now to FIGS. 7 and 10 concurrently, the contour of the substantially closed-loop formed by the first set **140** of cleaning elements will be discussed. FIG. 10 illustrates a simplified longitudinal side profile of the top surface of the substantially closed-loop formed by distal par-elliptical wall **141**, the two arcuate rows **142-143**, and the proximal par-elliptical wall **144**. As can be seen, the top surface **149** has a lateral side profile comprising a concave section **40** that extends from a peak **P** at a distal-most point of the distal par-elliptical wall **141** to a transition point **T** at a middle-portion of the two arcuate rows **142-143**. The lateral side profile also comprises a convex section **50** that extends from the transition point **T** to a proximal-most point **F** of the second par-elliptical wall **144**. The longitudinal side profile is essentially a stretched out S-shape.

[0051] Described another way, the first par-elliptical wall **141** has a first height **H1** at the first and second ends **241a,b** and a peak height **HP** at the location where the first par-elliptical wall **144** intersects (or hypothetically would intersect) the longitudinal axis **A-A**. The first par-elliptical wall **144** slopes upward from the first height **H1** to the peak height **HP** moving from the first and second ends **241a,b** to the location **P** where the first par-elliptical wall intersects the longitudinal axis **A-A**. When moving from the first par-elliptical wall **141** to the second par-elliptical wall **144**, the height of the first and second rows **142, 143** slopes downward for first a portion until a height **H2** is reached. After this, the height of the first and second rows **142, 143** then slopes upward for a second portion until a height **H3** is reached. At all points, the second par-elliptical wall **144** preferably has a height that is greater than the height **H2** and less than the peak height **HP**.

[0052] While a number of embodiments of the current invention have been described and illustrated in detail, various alternatives and modifications will become readily apparent to those skilled in the art without departing from the spirit and scope of the invention. As various changes could be made in the above methods, compositions and structures without departing from the scope of the invention, it is intended that all matter contained in this application, including all mechanisms and/or modes of interaction described above, shall be interpreted as illustrative only and not limiting in any way the scope of the appended claims.

THE CLAIMS DEFINING THE INVENTION ARE AS FOLLOWS:

1. A toothbrush comprising:

5 a handle:

a head connected to the handle, the head having a proximal periphery, a distal periphery, a first surface and a longitudinal axis;

10 a first set of cleaning elements forming a loop that extends from the distal periphery of the head to the proximal periphery of the head, the first set of cleaning elements comprising:

a first par-elliptical wall of cleaning elements located at the distal periphery of the head, the first par-elliptical wall terminating in a first end and a second end;

15 a second par-elliptical wall of cleaning elements located at the proximal periphery of the head, the second par-elliptical wall terminating in a first end and a second end;

a first row of cleaning elements extending from the first end of the first par-elliptical wall to the first end of the second par-elliptical wall; and

20 a second row of cleaning elements extending from the second end of the first par-elliptical wall to the second end of the second par-elliptical wall;

25 wherein a top surface of the loop has a longitudinal side profile that is a stretched-out S-shape, and wherein the first and second rows are first and second arcuate rows symmetrically arranged about the longitudinal axis and a lateral axis of the head, the first and second arcuate rows separated by a first distance that increases with distance from the lateral axis.

2. The toothbrush of claim 1 wherein the first and second rows are arcuate walls having peripheral convex surfaces that face the longitudinal axis.

30 3. The toothbrush of claim 1 further comprising:

a third row of cleaning elements extending adjacent to the first row and located along a first lateral periphery of the head, the third row located outside of the loop, the third row extending upward from the first surface at an incline so as to diverge from the first row, the third row having a height that is greater than a height of the first row; and

35 a fourth row of cleaning elements extending adjacent to the second row and located along a second lateral periphery of the head, the fourth row located outside of the

loop, the fourth row extending upward from the first surface at an incline so as to diverge from the second row, the fourth row having a height that is greater than a height of the second row.

- 5 4. The toothbrush of claim 3 further comprising:
a first elastomeric cup located within the first par-elliptical wall;
a second elastomeric cup located between the first and second rows; and
a third elastomeric cup located within the second par-elliptical wall.
- 10 5. The toothbrush of claim 4 further comprising a first annular gap between the first elastomeric cup and the first par-elliptical wall and a second annular gap between the third elastomeric cup and the second par-elliptical wall.
- 15 6. The toothbrush of claim 5 wherein the first, second and third elastomeric cups are located along the longitudinal axis of the head.
7. The toothbrush of claim 6 further comprising:
a first elongated cleaning element extending along a central axis of the first elastomeric cup that is taller than the first elastomeric cup;
20 a second elongated cleaning element extending along a central axis of the second elastomeric cup that is taller than the second elastomeric cup; and
a third elongated cleaning element extending along a central axis of the third elastomeric cup that is taller than the third elastomeric cup.
- 25 8. The toothbrush of claim 7 further comprising a first pair of elongated cleaning elements located between the first and second elastomeric cups within the loop and a second pair of elongated cleaning elements located between the second and third elastomeric cups within the loop.
- 30 9. The toothbrush of claim 1 wherein a distal-most portion of the first par-elliptical wall of cleaning elements extends upward from the first surface of the head in an inclined manner away from the handle; and wherein a proximal-most portion of the second par-elliptical wall of cleaning elements extends upward from the first surface of the head in an inclined manner toward the handle.

35

1/10

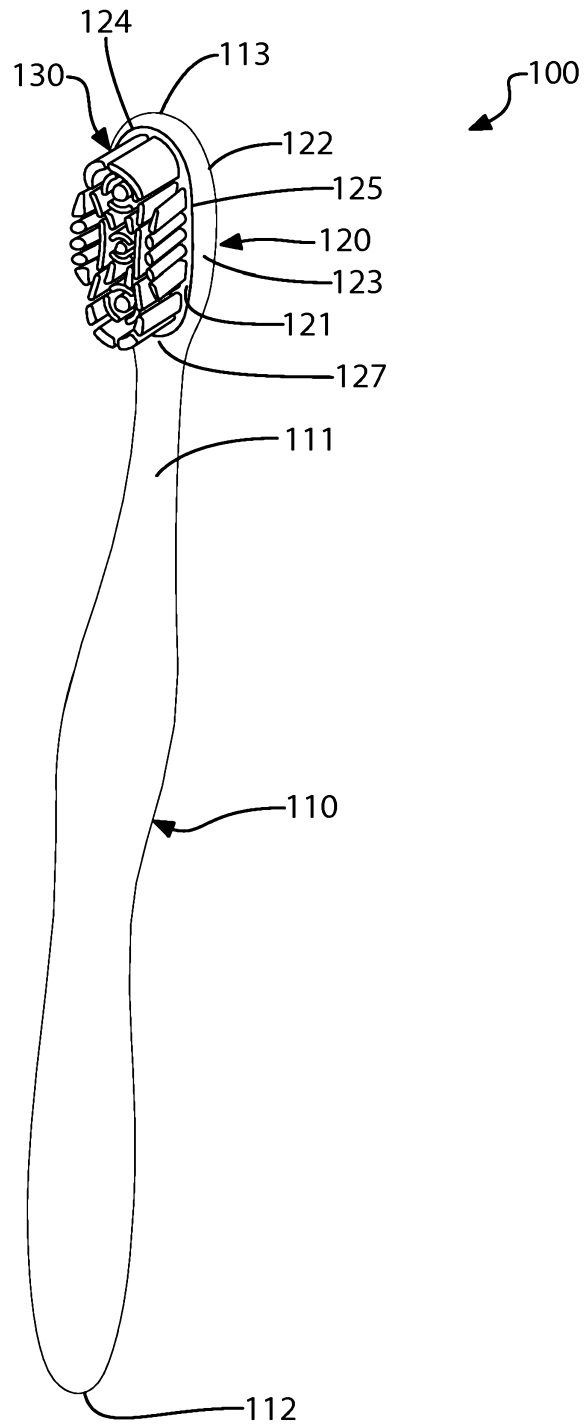

FIG. 1

2/10

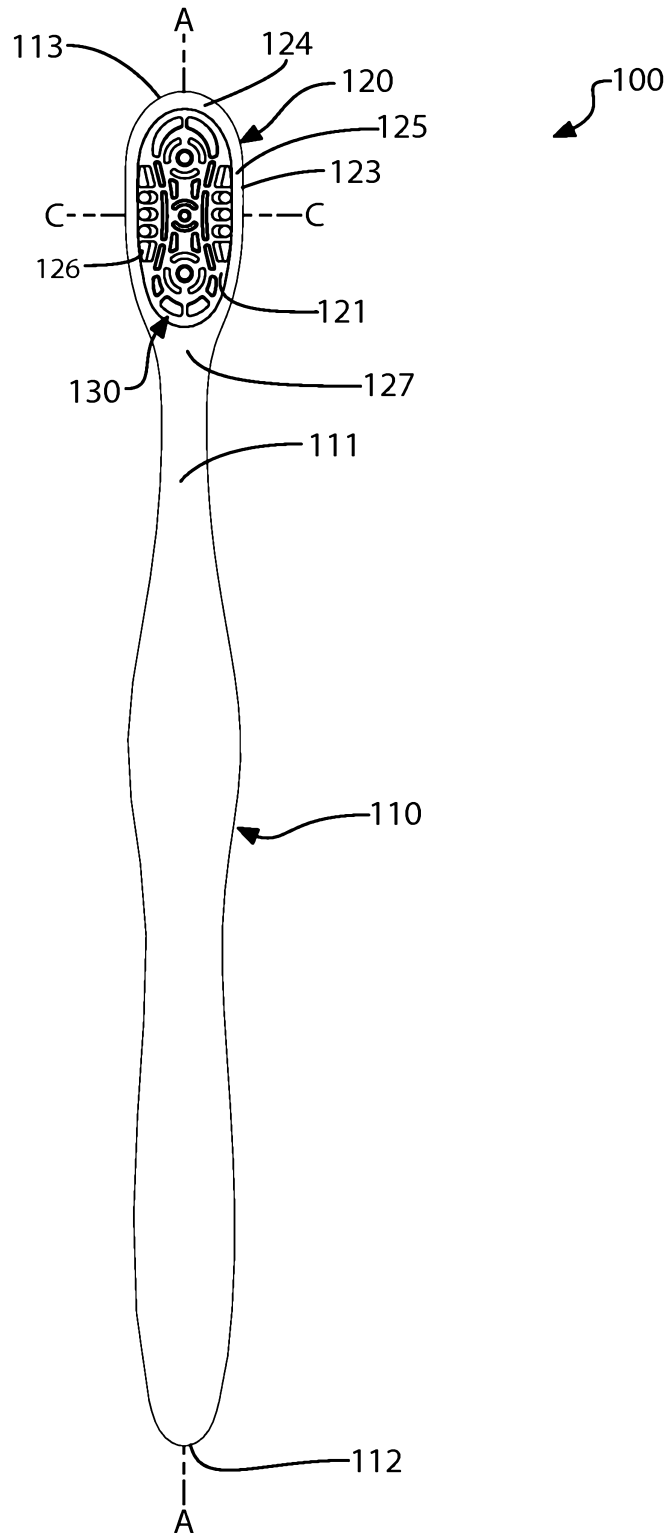

FIG. 2

3/10

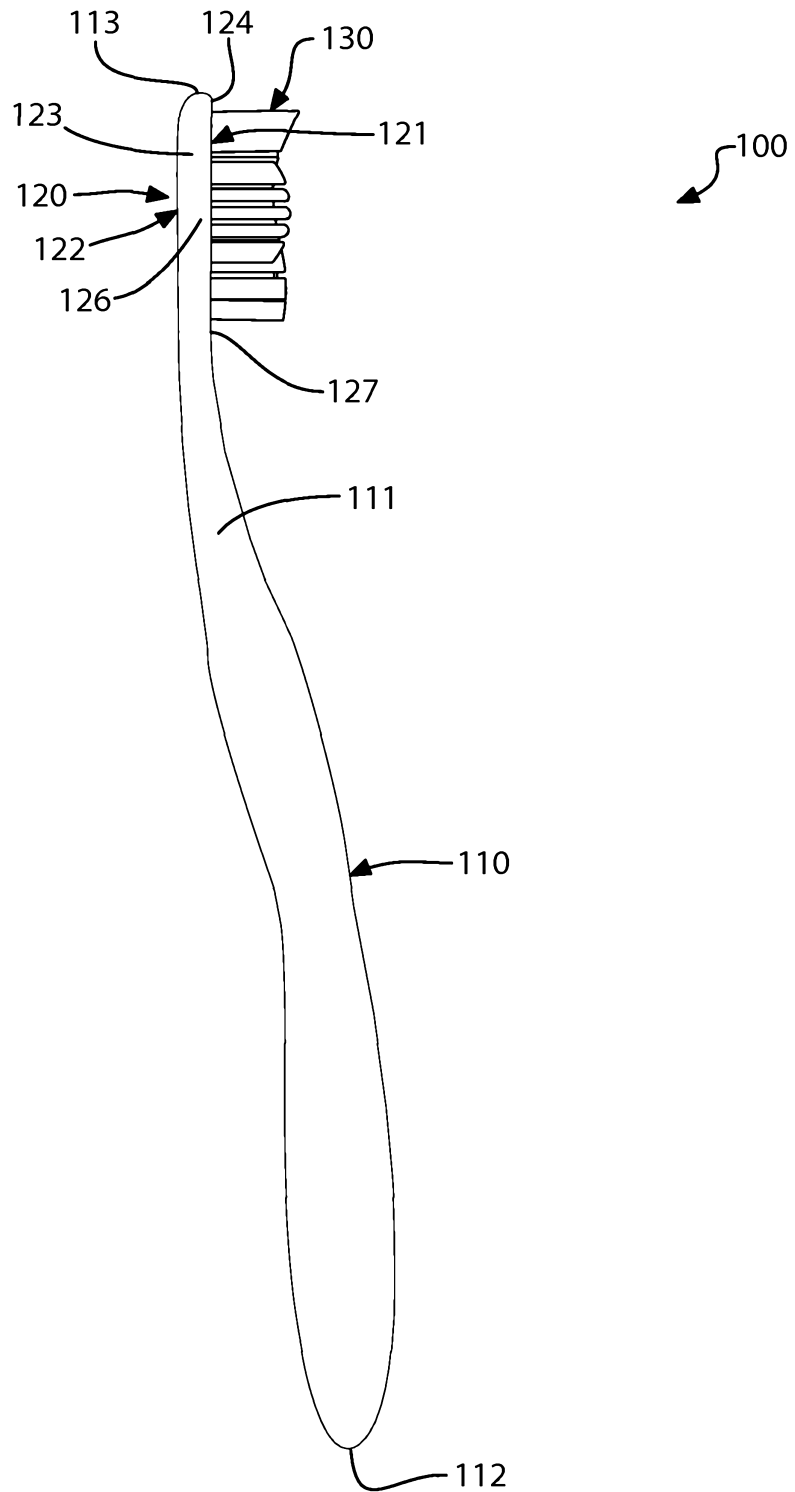

FIG. 3

4/10

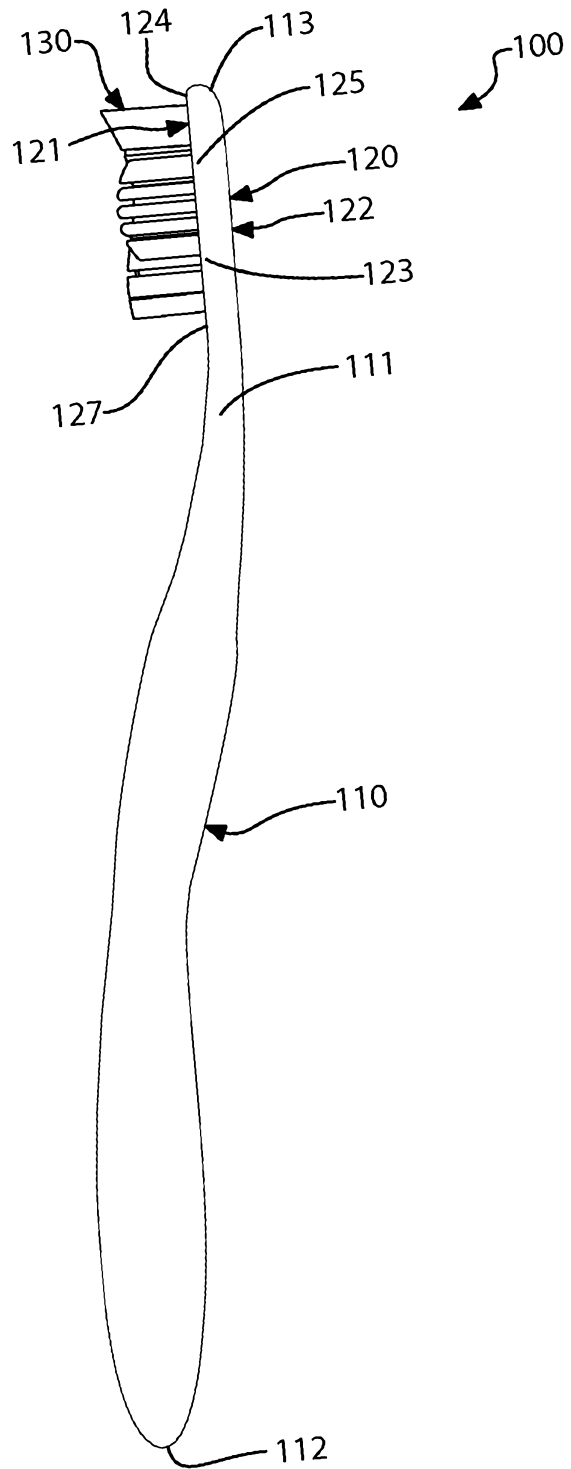

FIG. 4

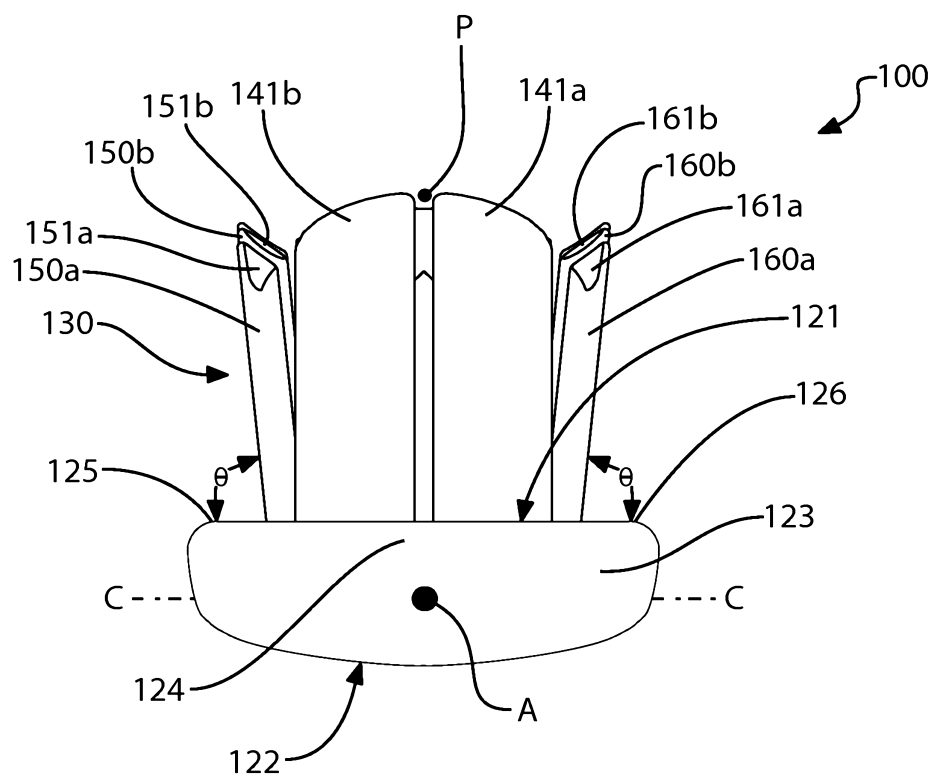

FIG. 5

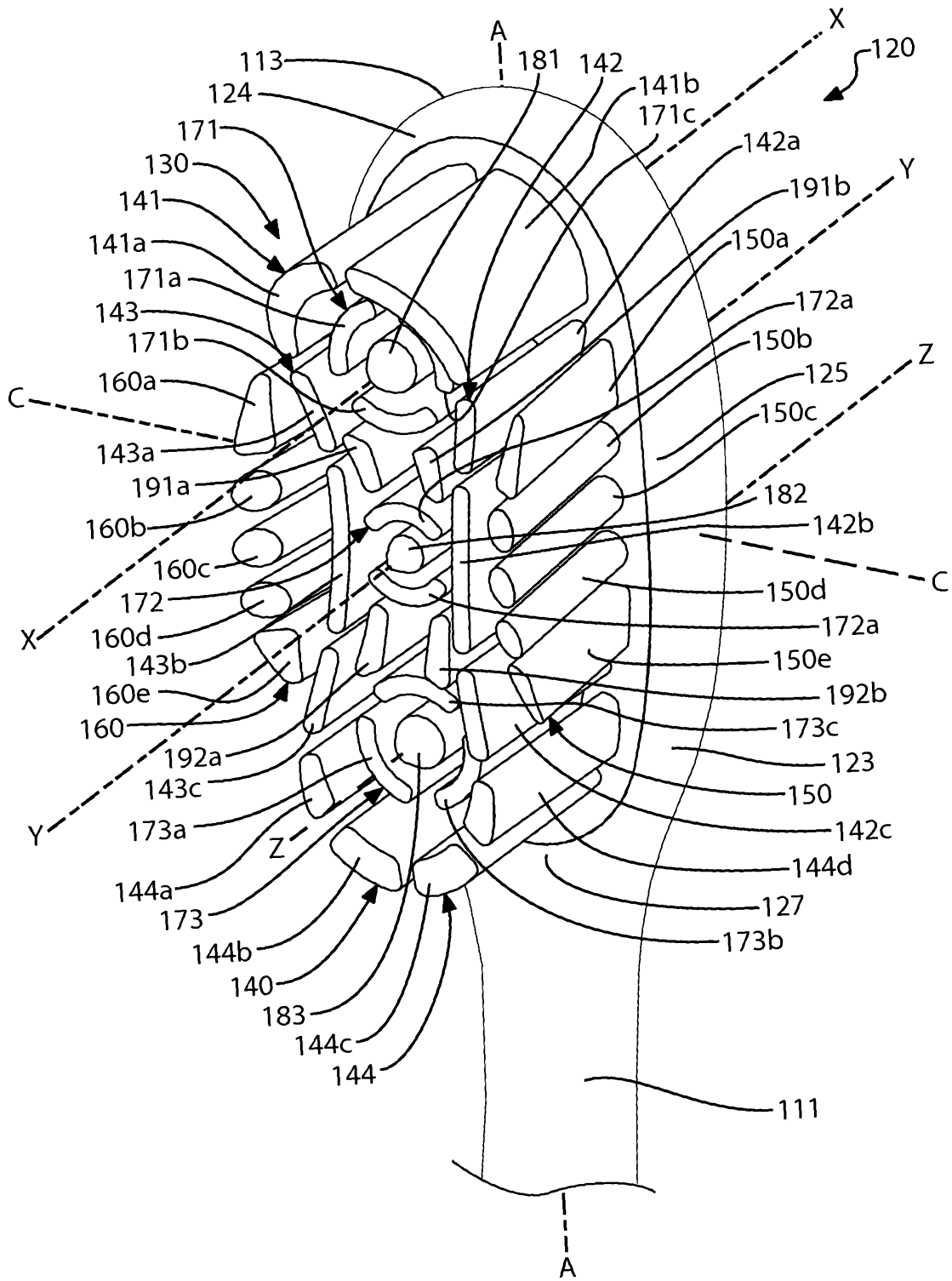

FIG. 6

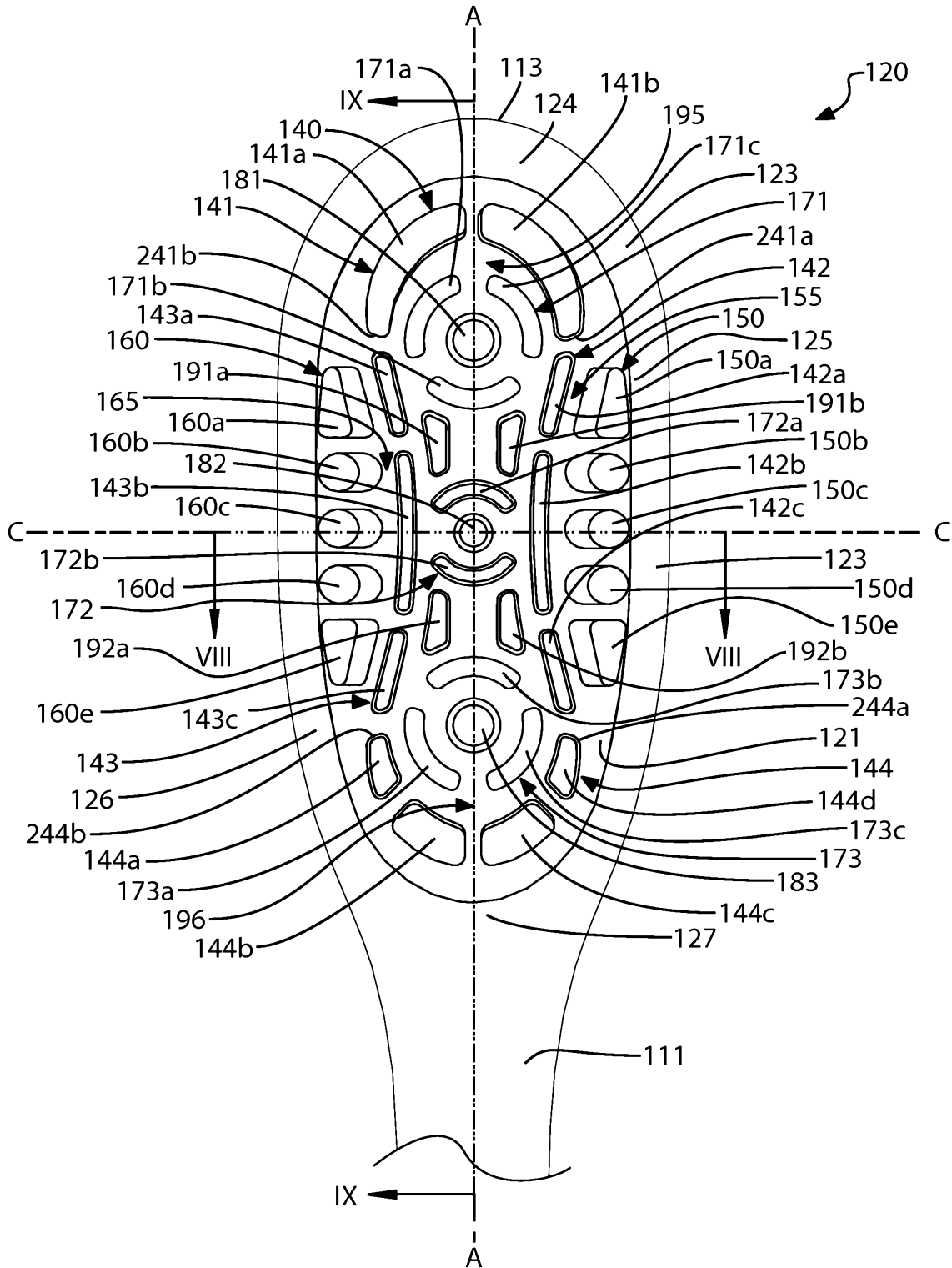

FIG. 7

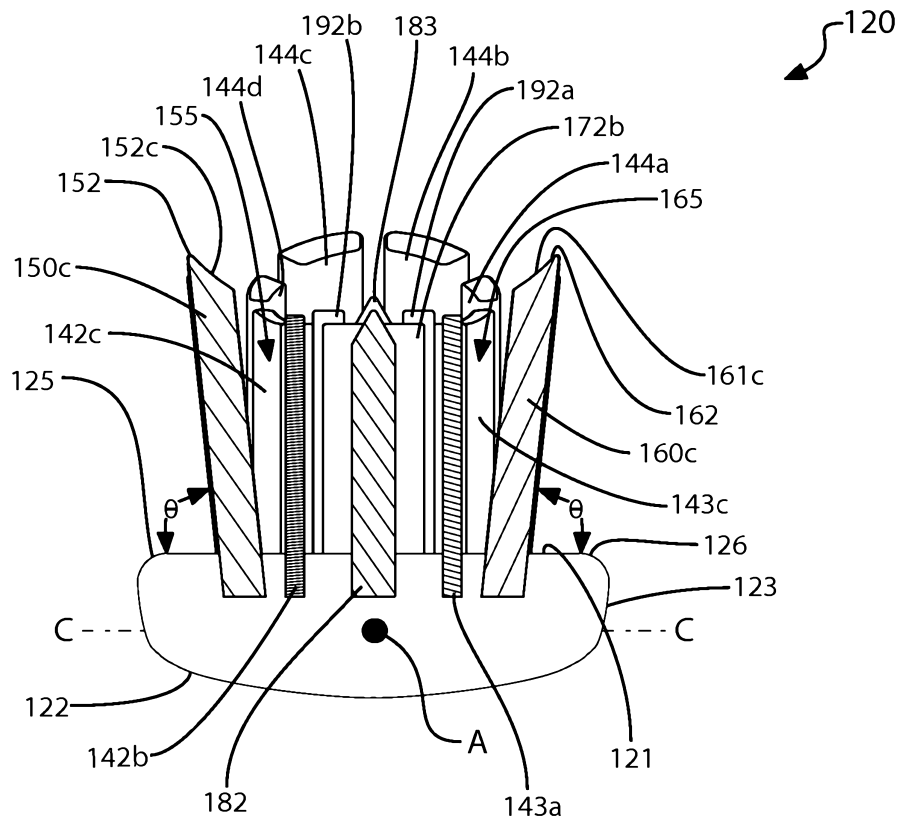

FIG. 8

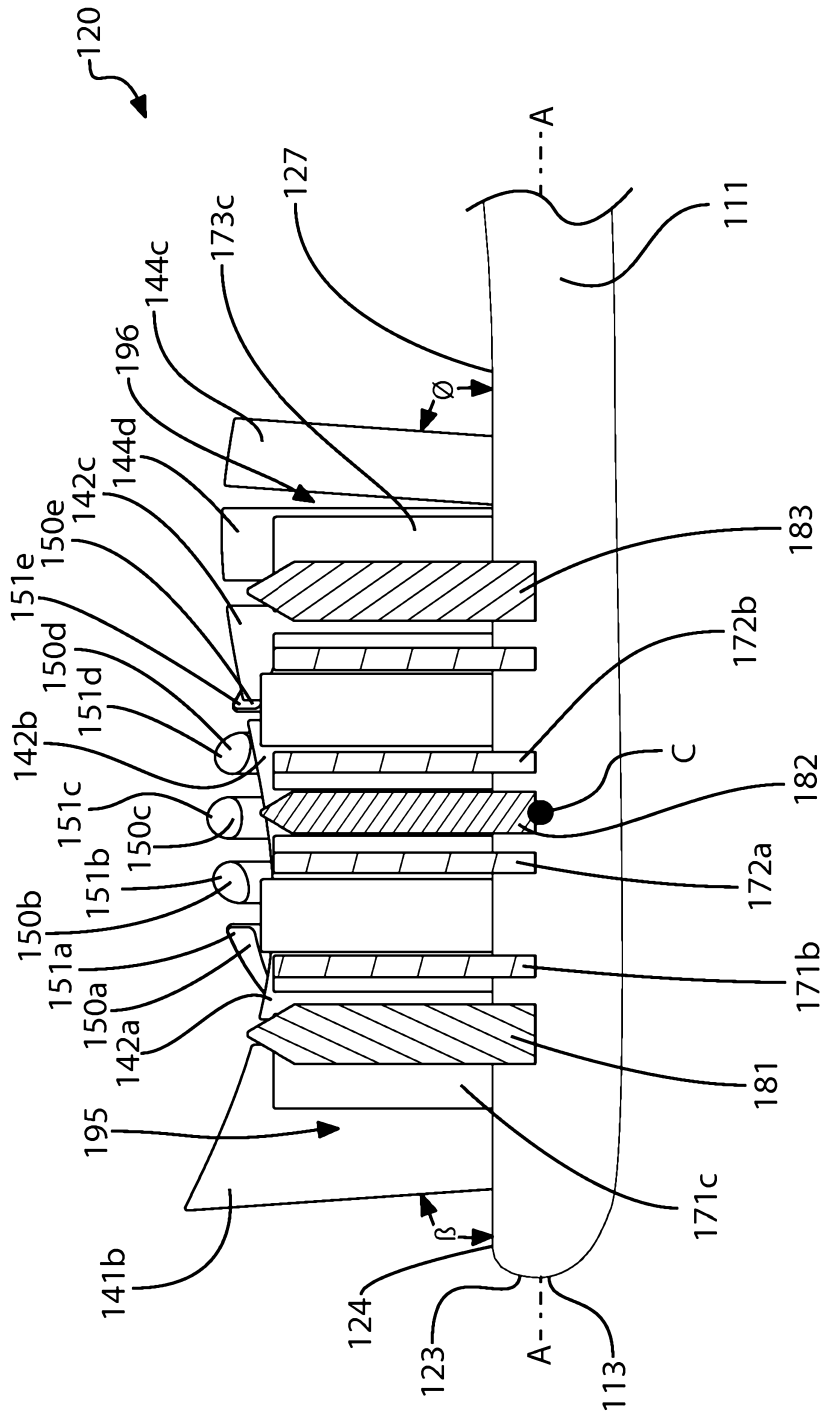

FIG. 9

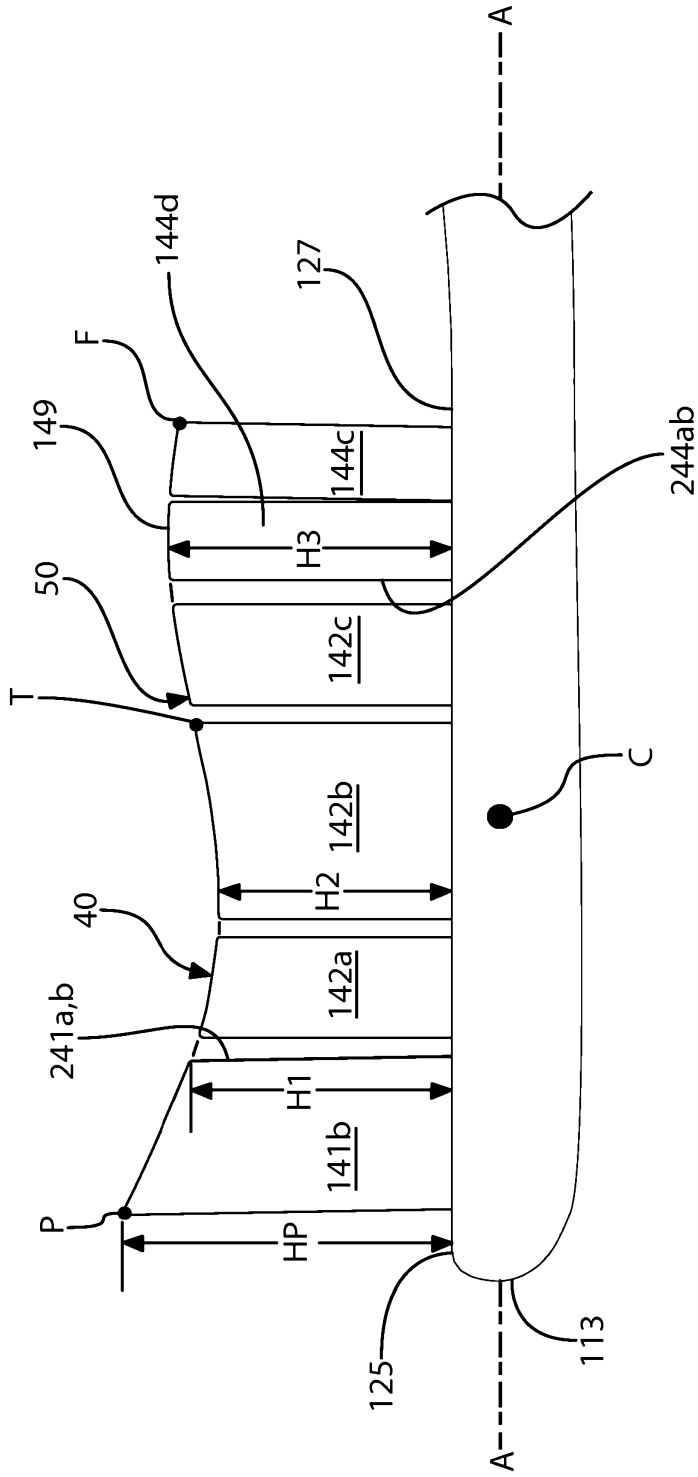

FIG. 10