

(19) World Intellectual Property
Organization
International Bureau



(43) International Publication Date
5 February 2004 (05.02.2004)

PCT

(10) International Publication Number
WO 2004/010891 A1

(51) International Patent Classification⁷: **A61C 8/00**,
A61L 27/54

(21) International Application Number:
PCT/SE2003/001110

(22) International Filing Date: 26 June 2003 (26.06.2003)

(25) Filing Language: Swedish

(26) Publication Language: English

(30) Priority Data:
0202319-0 25 July 2002 (25.07.2002) SE

(71) Applicant (for all designated States except US): **NOBEL
BIOCARE AB (publ)** [SE/SE]; Box 5190, S-402 26 Göte-
borg (SE).

(72) Inventor; and

(75) Inventor/Applicant (for US only): **HALL, Jan** [SE/SE];
Stabbegatan 2A, S-416 80 Göteborg (SE).

(74) Agent: **OLSSON, Gunnar**; Nobel Biocare AB (publ),
Box 5190, S-402 26 Göteborg (SE).

(81) Designated States (national): AE, AG, AL, AM, AT, AU,
AZ, BA, BB, BG, BR, BY, BZ, CA, CH, CN, CO, CR, CU,
CZ, DE, DK, DM, DZ, EC, EE, ES, FI, GB, GD, GE, GH,
GM, HR, HU, ID, IL, IN, IS, JP, KE, KG, KP, KR, KZ, LC,
LK, LR, LS, LT, LU, LV, MA, MD, MG, MK, MN, MW,
MX, MZ, NO, NZ, OM, PH, PL, PT, RO, RU, SC, SD, SE,
SG, SK, SL, TJ, TM, TN, TR, TT, TZ, UA, UG, US, UZ,
VC, VN, YU, ZA, ZM, ZW.

(84) Designated States (regional): ARIPO patent (GH, GM,
KE, LS, MW, MZ, SD, SL, SZ, TZ, UG, ZM, ZW),
Eurasian patent (AM, AZ, BY, KG, KZ, MD, RU, TJ, TM),
European patent (AT, BE, BG, CH, CY, CZ, DE, DK, EE,
ES, FI, FR, GB, GR, HU, IE, IT, LU, MC, NL, PT, RO,
SE, SI, SK, TR), OAPI patent (BF, BJ, CF, CG, CI, CM,
GA, GN, GQ, GW, ML, MR, NE, SN, TD, TG).

Published:

— with international search report

For two-letter codes and other abbreviations, refer to the "Guid-
ance Notes on Codes and Abbreviations" appearing at the begin-
ning of each regular issue of the PCT Gazette.

(54) Title: ARRANGEMENT FOR INCREASING THE STRESS RESISTANCE OF IMPLANTS, AND ONE SUCH IMPLANT

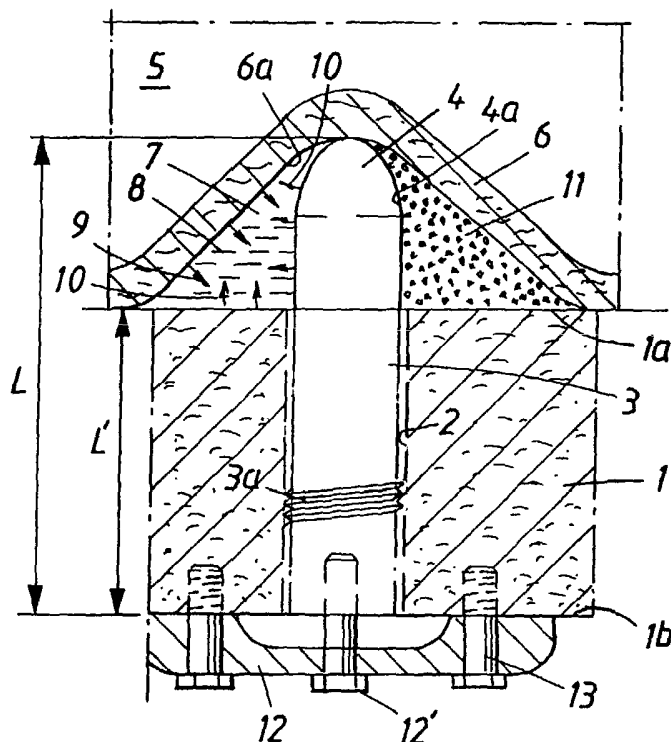

(57) Abstract: An arrangement and an implant are provided for increasing the stress resistance of the implant arranged in an upper jaw bone (1). The implant has access via parts (9, 4') to the sinus cavity (5). At said parts, the implant is arranged with a convex or rounded front surface which, upon access, lifts the sinus mucous membrane, without piercing the latter, and thus forms a closed space (7) between the parts and the underside of the mucous membrane. The implant is provided, at least at said parts, with growth-stimulating substance or substances (15) which interact with cell-containing body fluid (8) which penetrates or has penetrated into the space, so that new bone (11) is formed around said parts of the implant.

WO 2004/010891 A1

Arrangement for increasing the stress resistance of implants, and one such implant.

The present invention relates to an arrangement for
5 increasing the stress resistance of implants arranged
in an upper jaw bone. The invention moreover relates to
an implant for this purpose and made of titanium or of
another biocompatible material, for example ceramic.

10 In connection with implants, there is a need to be able
to increase the implant's stability in the jaw bone so
that the implant does not collapse after having been
exposed for some time to stresses which arise, for
example, during chewing movements. It is known, in this
15 connection, that the stability can be increased by
means of the length of the implant being increased,
i.e. the implant being anchored in a greater mass of
jaw bone.

20 The present invention starts out from this
understanding and proposes an arrangement and implants
permitting this increase in length, which means that
patients who for various reasons, for example poor
upper jaw status, have hitherto been able to be
25 provided with implants only of short lengths, for
example implant lengths of 7-8 mm, can now be provided
with implants having greater lengths, for example 10 mm
or more. With the previously known technique, patients
even had to do without the implant fixtures in
30 question, due to the fact that the lengths which could
be used on the patients were too short. The invention
solves these problems, among others, and allows the
implant length to be increased in relation to what was
previously possible, and more independently of, for
35 example, the upper jaw status.

The feature which can principally be regarded as
characterizing an arrangement according to the
invention is, inter alia, that the implant has a length

- 2 -

which requires that the implant must be given access at parts to the sinus cavity and that the implant, at said parts, is arranged with a convex or rounded front surface which, upon access, lifts the sinus mucous membrane, without piercing the latter, and thus forms a closed space between the parts and the underside of the mucous membrane. The implant is provided, at least at said parts, with growth-stimulating substances which interact with cell-containing body fluid which has penetrated into the space, so that new bone is formed around said parts of the implant and thereby effects said resistance.

In a preferred embodiment, the convex or rounded front surface and at least one contiguous outer surface of the implant situated in the sinus are coated with layers of growth-stimulating substances. Said contiguous outer surface, and possibly at least parts of the front surface, are arranged with a rough outer layer or porous outer oxide layer(s) functioning as a reservoir for said growth-stimulating substance or substances. The roughness on the front surface is in this case designed not to cause penetration through the mucous membrane.

In one embodiment, the implant can be made of titanium and can be coated with growth-stimulating substance or substances, here called GSS, along most of its length. The growth-stimulating substance or substances can be matrix molecules, growth factors and differentiation factors and/or peptides with growth-stimulating properties. Other types of GSS can also be used. The implant can also be arranged in an upper jaw bone with reduced height, and the anchoring of the implant in the initial stage can in this case be complemented by mechanical anchoring elements, for example stiff membranes, which can be connected to the outer surface of the upper jaw bone. After incorporation, the

- 3 -

anchoring is dependent on the degree of insertion of the implant in the sinus. The greater the degree of insertion, the greater the enclosed space, which means that the interacting body fluids and substances effect
5 a greater formation of new bone around the implant.

The arrangement also comprises a member which can be introduced into a jaw bone hole extending from the outside of the jaw bone and opening into the sinus on
10 the underside of the sinus mucous membrane. In the inserted position below said underside, the member is designed to effect a rotation movement as a function of a turning action, preferably of a manual type. The member has one or more front parts which are designed
15 to be able to pass in between the boundary wall of the sinus and the underside of the mucous membrane and, upon said rotation movement or rotation movements, to free parts of the mucous membrane from the boundary wall of the sinus.

20 An implant according to the invention is characterized principally in that it is arranged with a convex or rounded front surface which can cooperate with the mucous membrane in the sinus, via the underside of the
25 mucous membrane, to form an enclosed space between the implant and the underside of the mucous membrane. At least the parts which penetrate or have penetrated into the sinus are coated with growth-stimulating substance or substances arranged to interact with cell-containing
30 body fluid in said enclosed space in order to form new bone around the front surface and the parts.

In a preferred embodiment, the parts of the implant on the outside in the sinus are designed with a roughened
35 outer surface or porous outer oxide layer arranged to store said substance or substances.

- 4 -

By means of what has been proposed above, growth-stimulating substance or substances (GSS) can be used effectively, and examples of GSS which may be mentioned are matrix molecules, growth factors and
5 differentiation factors and/or peptides with growth-stimulating properties. In accordance with the invention, the mucous membrane must be protected against mechanical action, and this is achieved effectively by the proposed lifting function, in
10 possible combination with the release function between the mucous membrane and the wall of the sinus. By means of what is proposed, it is possible to create an effectively enclosed space in which the cell-containing fluid can gain access and effectively interact with the
15 GSS which is released from the implant.

A presently proposed embodiment of an arrangement and of an implant according to the invention will be described below with reference to the attached
20 drawings, where

Figure 1 shows, in vertical section, an implant which is fitted in a hole in the upper jaw bone and whose front parts have passed into the sinus and cooperate with the mucous membrane, at
25 the underside thereof, so that a closed space for production of new bone is created,

Figure 2 shows, in a vertical view, and enlarged in relation to Figure 1, the configuration of the front surface of the implant and parts
30 ~~penetrating into the sinus,~~

Figure 3 shows, in vertical section, and enlarged in relation to Figure 2, parts of the front surface with applied growth-stimulating
35 substance or substances,

- 5 -

Figure 4 shows, in vertical section, other parts of the implant's side surfaces which are coated with layers of growth-stimulating substance or substances, which outer sides can comprise one or more threads,

Figure 5 shows, in a vertical view, a second embodiment of the front surface of the implant,

Figure 6 shows, in vertical view, a third embodiment of the front surface of the implant, and

Figure 7 shows, in vertical section, members or instruments which, before lifting of the mucous membrane of the sinus, are intended to free the latter from the inner surface of the sinus.

In Figure 1, an upper jaw bone is represented by 1. A hole 2 with an internal thread has been formed in the jaw bone. An implant 3 has been fitted in the hole in the jaw bone, its front parts 4a passing into a sinus 5. The insertion in this case is such that the front parts 4 have lifted the mucous membrane 6 of the sinus by means of the implant's front parts 4 cooperating with the mucous membrane at the underside 6a thereof. It is important here that the lifting is done in such a way that the mucous membrane 6 is not pierced by the implant or is not damaged in a way which would involve a risk of its later becoming pierced. The lifting of the mucous membrane 6 results in an enclosed space 7 being formed between the underside 6a of the mucous membrane and the outer surface 4a of the outer parts. Body fluid 8 passes into the enclosed space from the body tissue in accordance with arrows 9 and 10. At least said front parts 4 of the implant are provided, on said outer surface 4a, with growth-stimulating

- 6 -

substance or substances which interact with said body fluid 8. The substance or substances are initially applied in a specific amount and concentration on said surface 4a, and said interaction from said layer is represented in the figure by arrows 10. In Figure 1, the formation of new bone has been symbolized by 11. Two stages have been indicated in the figure. In the first stage (see to the left of the front surface 4a), the body fluid accumulation and the initial interaction are indicated. In the second stage (see to the right of the front parts 4), the completed formation of new bone is indicated. The figure also shows an inner surface 1a of the upper jaw bone, against which inner surface the underside 6a of the mucous membrane 6 bears before lifting. The implant can be of the self-tapping type or of the type fitted in a previously formed thread in the jaw bone hole 2. In Figure 1, parts of an outer thread on the implant 3 have been indicated by 3a. Other parts of the implant can also be provided with amounts or concentrations of growth-stimulating substance or substances lying on the outside. Application of GSS to the implant 4 can be carried out in different ways, and with variations as regards the extent of the substance or substances along the length and circumference of the implant. The implant has a length L in accordance with the above. The height or length L' of the dentine can vary as a function of the patient, jaw bone status, etc. The degree of insertion of the implant, i.e. L-L', is dependent inter alia on the length or height L'. If the length or height is small, it may be important to increase stability by means of the new bone formation in the closed space 7, which in such a case entails a greater degree of insertion of the front parts 4a of the implant. The implant can be anchored to the jaw bone 1 temporarily or permanently using a mechanical securing arrangement 12, for example a stiff membrane, which is secured with screws 13 in the jaw bone, at the outer surface 1b thereof. Alternatively, or in addition

- 7 -

to this, the membrane or reinforcement can be secured by a screw 12' which is screwed into an inner threaded hole in the implant. The design of the implant itself can be of a type known per se, and in this connection
5 reference may be made to the "Brånemark" system.

Figure 2 is an enlarged view showing the configuration of the front surface 4 in Figure 1. The front surface is designed with an evenness which avoids mechanical
10 impact on the mucous membrane when the implant is inserted into the sinus. The front surface can have a polished part 14 and, if appropriate, can be designed with a surface roughness or porous layer 14a at the sides. The surface roughness or porous layer in this
15 case functions as a reservoir for layers of GSS. The parts 4' contiguous to the front surface 4 can also be provided with said surface roughness or porous layer and can be charged with said GSS.

20 Figure 3 shows the surface roughness 14 on the front surface 4 in an enlarged view compared to Figure 2. A layer of GSS applied to the surface roughness is indicated by 15.

25 In accordance with the above, the rest of the implant 3 can be coated completely or partially with GSS of a chosen amount and concentration 16. The thickness of the applied GSS can, for example, lie in the range of, for example, a few Ångström to a few micrometers, a few
30 nanometers. In the example according to Figure 4, a coating has been applied to an outer thread 16 with a ~~GSS amount or GSS concentration 17. In the figures, the~~ GSS has been symbolized by broken lines 15, 16.

35 In accordance with Figure 5, the front surface 4'' can be designed in different ways. The front surface can be substantially plane or form an only slightly rounded front surface 18 which, at its periphery, has been

provided with bevels 18a, 18b so as not to cause damage to the aforementioned mucous membrane 6.

Figure 6 shows a further embodiment of the front surface 4''', which in this case has the basic shape of a sphere 19.

In accordance with Figure 7, the mucous membrane 6 can, at its underside 6a, be more or less firmly attached to or in the inner surface 1a of the upper jaw bone 1. In this case it is advantageous to use a certain release function. The purpose of the release function is to free the mucous membrane 6 from the inner surface 1a before the lifting in accordance with Figure 1 is carried out. Said release can be done with the aid of an instrument or member 20 which at its front part has a blade-shaped part 21. After passing through the jaw bone hole 22, said part 21 can be driven in between the inner surface 1a of the jaw bone and the underside 6a of the mucous membrane 6 so as to effect a release function between the jaw bone and the mucous membrane. Figure 7 shows this initial stage. The member 20 can be given a rotation movement 22 about its longitudinal axis 23, which results in the mucous membrane 6 being freed from the inner surface 1a around the mouth 2a where the jaw bone hole opens into the sinus. In Figure 7, an initial stage for formation of the space 7 in Figure 1 has commenced. The initial space which has been created with the member 20 in the stage shown in Figure 7 has been indicated by 7'. It will be appreciated that the member 20 and its insertion and releasing parts 21 can be designed in different ways. Thus, the member 20 can be provided with several parts 21. The parts can be arranged to be resilient relative to the longitudinal part 24 of the member. The part or parts 21 can be provided with rounded surfaces cooperating with the mucous membrane 6 so that the latter is not damaged by the member 20 during the

initial release. The invention has been described above such that the mucous membrane 6 is considered as belonging to the sinus, like any space between the underside 6a of the mucous membrane and the top surface
5 1a of the jaw bone.

The invention is not limited to the embodiment shown above by way of example, and instead it can be modified within the scope of the attached patent claims and the
10 inventive concept.

Reference may be made here to patent applications submitted to the Swedish patent office on the same day as the present patent application and by the same
15 Applicant and inventor. Said applications have the following titles:

- a) "Arrangement for using osteoinductive or bioactive material to induce bone and/or increase the
20 stability of implants in the jaw bone, and an implant intended for this purpose".
- b) "Arrangement for using bioactive or osteoinductive material to build up a bone-based lateral support
25 for implants in the jaw bone".
- c) "Arrangement for implants bearing growth-stimulating substance or substances, and one such
30 implant".
- d) "Arrangement of two or more implants provided
with growth-stimulating substance(s)".

PATENT CLAIMS

1. An arrangement for increasing the stress
5 resistance of implants arranged in an upper jaw
bone (1), characterized in that the implant has a
length (L) which requires that the implant must be
given access at parts (4, 4') to the sinus cavity
10 (5), in that the implant, at said parts, is
arranged with a convex or rounded front surface
(4, 4a) which, upon access, lifts the sinus mucous
membrane (6), without piercing the latter, and
15 thus forms a closed space (7) between the parts
(4, 4') and the underside of the mucous membrane,
and in that the implant is provided, at least at
said parts, with growth-stimulating substance(s)
(15) which interact with cell-containing body
20 fluid (8) which has penetrated or is penetrating
into the space, so that new bone (11) is formed
around said parts of the implant and thereby
increases the resistance.
2. The arrangement as claimed in patent claim 1,
25 characterized in that the convex or rounded front
surface (4) and at least one contiguous outer
surface (4') of the implant situated in the sinus
are coated with layers of growth-stimulating
substance or substances (15).
- 30 3. The arrangement as claimed in patent claim 2,
characterized in that at least sides of said
~~rounded front surface and contiguous outer surface~~
(4a) are arranged with rough outer layers or
porous outer oxide layer(s) (14) functioning as a
35 reservoir for said growth-stimulating substance or
substances.

4. The arrangement as claimed in patent claim 1, 2 or 3, characterized in that the implant (3) is made of titanium and is coated with growth-stimulating substance or substances along most of its length (L).
- 5
5. The arrangement as claimed in any of patent claims 1-4, characterized in that the growth-stimulating substance or substances are matrix molecules, growth factors and differentiation factors and/or peptides with growth-stimulating properties.
- 10
6. The arrangement as claimed in any of patent claims 1-5, characterized in that the implant is arranged in an upper jaw bone with reduced height (L').
- 15
7. The arrangement as claimed in any of patent claims 1-6, characterized in that, in an initial stage, the implant is provided at its outer parts with a mechanical anchoring member (12) which can be connected on or at the outer surface (1b) of the jaw bone.
- 20
8. The arrangement as claimed in any of patent claims 1-7, characterized in that the implant can be given an anchoring which is dependent on the degree of insertion (L-L') of the implant in the sinus, where, the greater the degree of insertion, the greater the enclosed space (7) for body fluid and the interaction between the substance and the substances and the cells in the body fluid, which means ~~greater area of formation of new bone, and~~ vice versa.
- 25
- 30
- 35 9. The arrangement as claimed in any of patent claims 1-8, characterized in that it comprises a member (20) which can be introduced into a jaw bone hole (2) extending from the outside (1b) of the jaw

- 12 -

bone and opening into the sinus on the underside of the sinus mucous membrane (6), in that, in the inserted position below said underside, the member is also designed to effect a rotation movement as a function of a turning action (22), preferably of a manual type, and in that one or more front parts of the member are designed to pass in between the boundary wall of the sinus or jaw bone and the underside (6a) of the mucous membrane and, upon said rotation movement or rotation movements, to free or release the mucous membrane from the boundary wall.

10. An implant preferably made of titanium or ceramic, characterized in that it is arranged with a convex or rounded front surface (4) which is designed to cooperate with a sinus mucous membrane (6) in the sinus, via the underside (6a) of the mucous membrane, to form an enclosed space (7) between the implant and the underside of the mucous membrane, in that at least the front surface and the parts which penetrate or have penetrated into the sinus are coated with growth-stimulating substance or substances arranged to interact with cell-containing body fluid (8) in order to form new bone around the front surface (4) and the parts (4').

11. The implant as claimed in patent claim 10, characterized in that the sides of the front surface and said parts are designed with a ~~roughened outer surface (14) or porous outer oxide layer~~ arranged to store said substance or substances.

Fig. 1

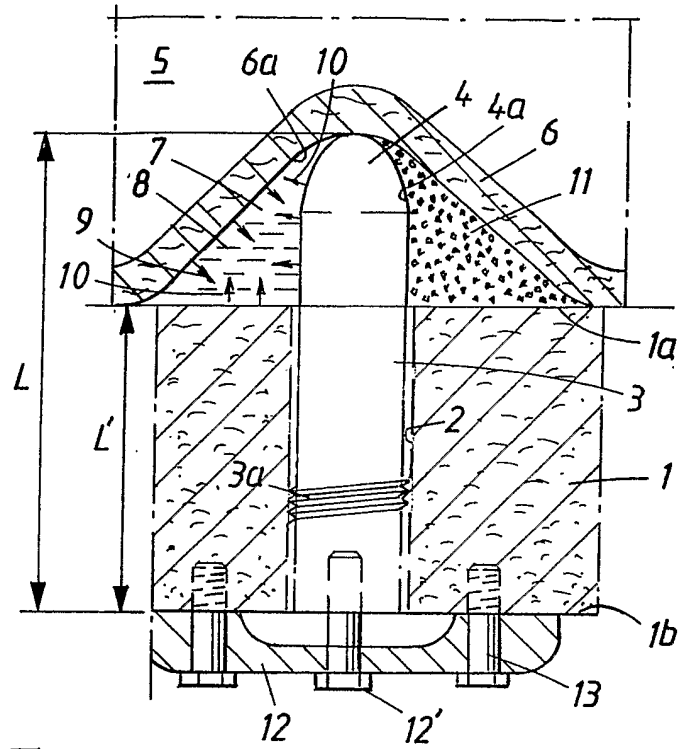

Fig. 2

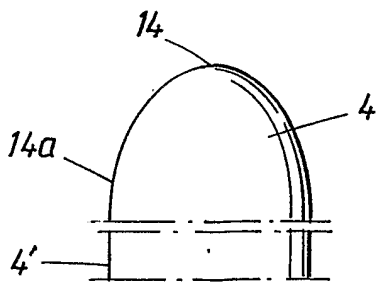

Fig. 3

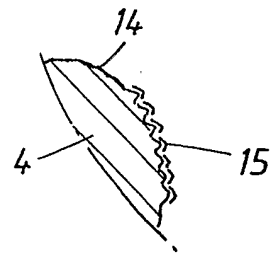

Fig. 4

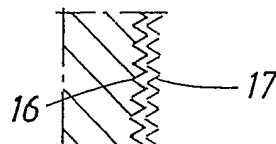

Fig. 5

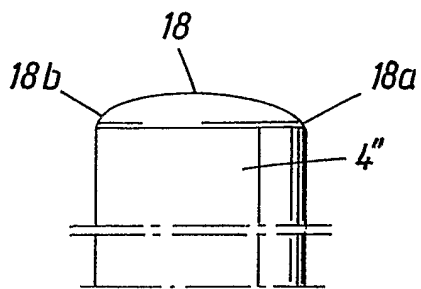

Fig. 6

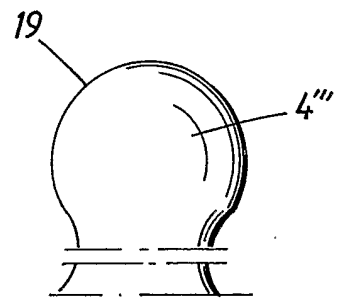
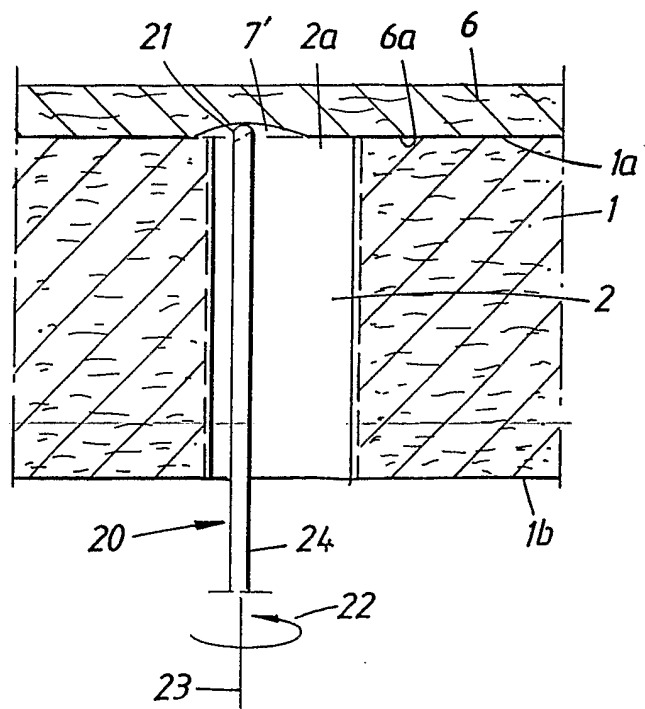

Fig. 7



INTERNATIONAL SEARCH REPORT

International application No.

PCT/SE 03/01110

A. CLASSIFICATION OF SUBJECT MATTER

IPC7: A61C 8/00, A61L 27/54

According to International Patent Classification (IPC) or to both national classification and IPC

B. FIELDS SEARCHED

Minimum documentation searched (classification system followed by classification symbols)

IPC7: A61C, A61L

Documentation searched other than minimum documentation to the extent that such documents are included in the fields searched

SE,DK,FI,N0 classes as above

Electronic data base consulted during the international search (name of data base and, where practicable, search terms used)

C. DOCUMENTS CONSIDERED TO BE RELEVANT

Category*	Citation of document, with indication, where appropriate, of the relevant passages	Relevant to claim No.
A	WO 0072775 A1 (NOBEL BIOCARE AB (PUBL)), 7 December 2000 (07.12.00) --	1-11
A	WO 0072776 A1 (NOBEL BIOCARE AB (PUBL)), 7 December 2000 (07.12.00) --	1-11
A	WO 0072777 A1 (NOBEL BIOCARE AB (PUBL)), 7 December 2000 (07.12.00) -- -----	1-11

 Further documents are listed in the continuation of Box C.
 See patent family annex.

* Special categories of cited documents:	"T" later document published after the international filing date or priority date and not in conflict with the application but cited to understand the principle or theory underlying the invention
"A" document defining the general state of the art which is not considered to be of particular relevance	"X" document of particular relevance: the claimed invention cannot be considered novel or cannot be considered to involve an inventive step when the document is taken alone
"E" earlier application or patent but published on or after the international filing date	"Y" document of particular relevance: the claimed invention cannot be considered to involve an inventive step when the document is combined with one or more other such documents, such combination being obvious to a person skilled in the art
"L" document which may throw doubts on priority claim(s) or which is cited to establish the publication date of another citation or other special reason (as specified)	"&" document member of the same patent family
"O" document referring to an oral disclosure, use, exhibition or other means	
"P" document published prior to the international filing date but later than the priority date claimed	

Date of the actual completion of the international search 7 October 2003	Date of mailing of the international search report 15-10-2003
Name and mailing address of the ISA/ Swedish Patent Office Box 5055, S-102 42 STOCKHOLM Facsimile No. +46 8 666 02 86	Authorized officer Jack Hedlund/Els Telephone No. +46 8 782 25 00

INTERNATIONAL SEARCH REPORT

Information on patent family members

06/09/03

International application No.

PCT/SE 03/01110

Patent document cited in search report	Publication date	Patent family member(s)	Publication date
WO 0072775 A1	07/12/00	AU 1589900 A	22/05/00
		AU 5260700 A	18/12/00
		CA 2372035 A	11/05/00
		CA 2373932 A	07/12/00
		EP 1191900 A	03/04/02
		EP 1241937 A	25/09/02
		JP 2003500158 T	07/01/03
		SE 515695 C	24/09/01
		SE 9901973 A	01/12/00
WO 0072776 A1	07/12/00	AU 1433300 A	29/05/00
		AU 5260800 A	18/12/00
		CA 2373701 A	07/12/00
		EP 1191901 A	03/04/02
		JP 2003500159 T	07/01/03
		SE 514202 C	22/01/01
		SE 9901974 A	01/12/00
WO 0072777 A1	07/12/00	AU 5260900 A	18/12/00
		CA 2373934 A	07/12/00
		EP 1055096 A	29/11/00
		EP 1196110 A	17/04/02
		IL 137908 D	00/00/00
		JP 2003500160 T	07/01/03
		SE 514323 C	12/02/01
		SE 9901971 A	01/12/00
US 6415715 B	09/07/02		