

Feb. 17, 1953

G. VAN EPS

2,628,524

GUITAR DAMPER

Filed Sept. 11, 1950

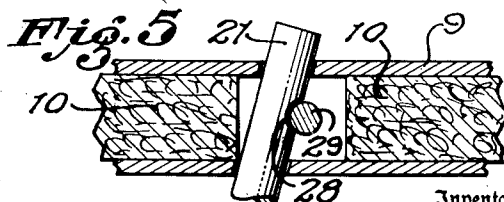
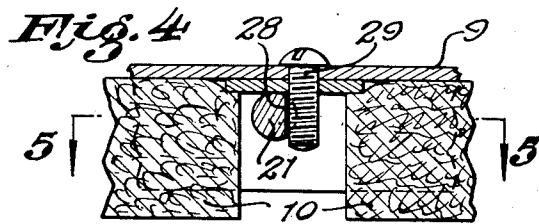
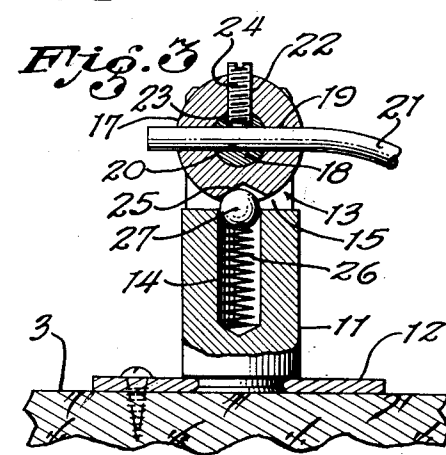
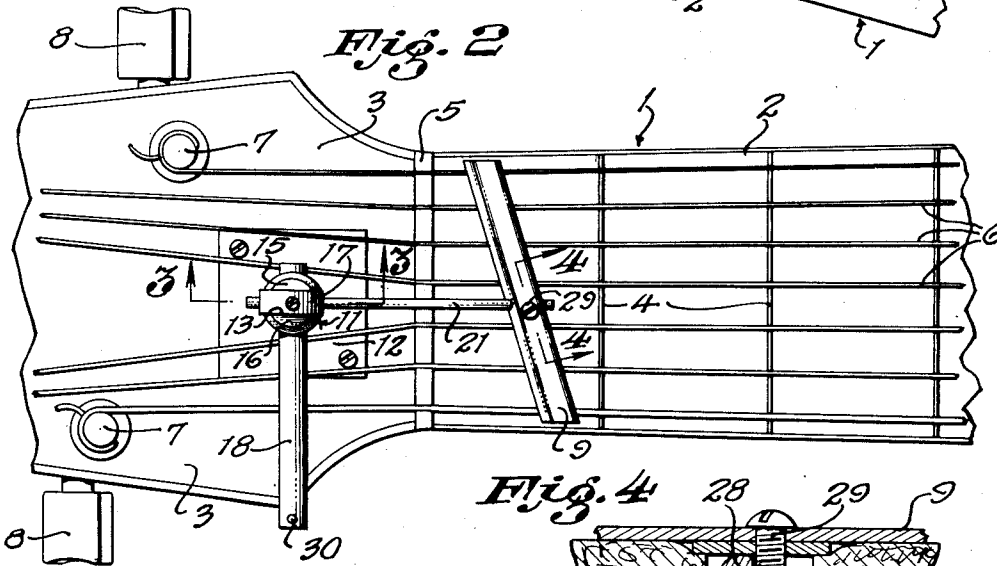
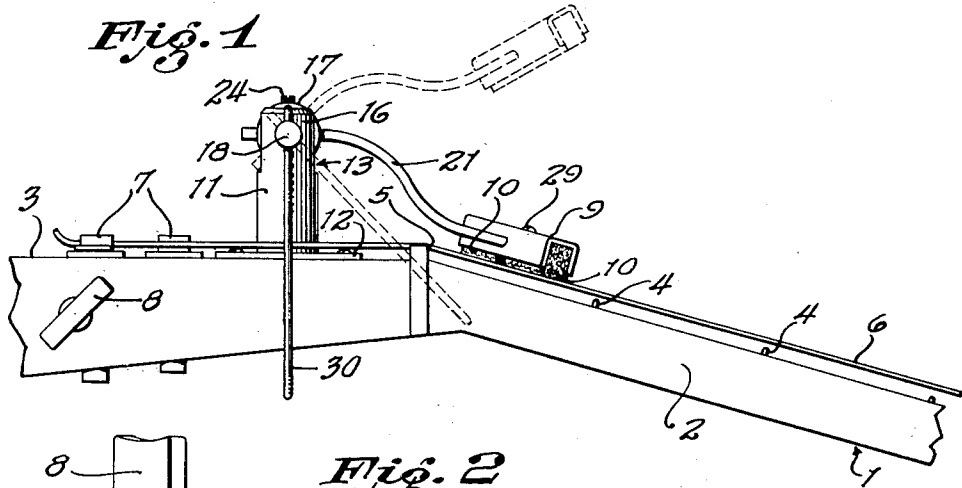

Inventor,  
**GEORGE VAN EPS**

31  
*Calvin Brown*  
Attorney

# UNITED STATES PATENT OFFICE

2,628,524

## GUITAR DAMPER

George Van Eps, Burbank, Calif.

Application September 11, 1950, Serial No. 184,147

7 Claims. (Cl. 84-267)

1

The present invention relates to dampers of the type which may be applied to stringed instruments, such as a guitar.

An object of the invention is the provision of a damper which effectively prevents overtones in the strings being plucked between the fretted note and the nut during playing of the instrument. This invention is to be distinguished from those devices which mute the strings, as the present invention does not so act, nor is the invention of the type which functions as a capo tasto, which is to say a device which will change stringed instruments, such as guitars, from sharps to flats.

With the advent of electrical amplification, sympathetic vibration of strings became a problem in that sympathetic vibration of strings other than those being played cause the listener to feel that the player is off key.

The overtones of the vibrating guitar strings are not necessarily complementary. For example, in the key of E flat, there is a G in the E flat chord, which is the third overtone of the key. If a guitar player plays an E flat chord staccato, the third of the chord, which is G, sympathetically vibrates its fifth, which is D. Hence there is a half-tone discrepancy. Dynamic expression and staccato effect are more or less nullified by overtones when the piece being played is of a solo nature.

In the drawing:

Figure 1 is a fragmentary side elevation of a portion of a head and neck of a guitar with the invention applied thereto;

Figure 2 is a fragmentary top plan view of the guitar shown in Figure 1;

Figure 3 is a sectional view, on an enlarged scale, on the line 3-3 of Figure 2;

Figure 4 is an enlarged fragmentary sectional view on the line 4-4 of Figure 2; and

Figure 5 is a fragmentary sectional view on the line 5-5 of Figure 4.

Referring now with particularity to the drawing, I have shown in Figures 1 and 2 a portion of a guitar 1 having a neck 2 and a head or scroll 3. The neck 2 is provided with series of transverse, spaced apart, frets 4 and a nut 5 over which strings 6 pass. The head 3 is provided with a series of pegs 7 which are turned by keys 8, the strings being wrapped around the said pegs, the pegs being turned by the keys to tension the strings 6. The average guitar has six strings, while others have seven or more, adapted to be played by the four fingers of the right-hand, while the fingers of the left-hand depress the

2

strings onto selected frets 4. As a device of this character often has electrical amplification means attached thereto, which is quite sensitive to sympathetic vibration between the strings 6, it becomes a problem to control the vibration of the open strings and the vibration of the lengths of strings between the fretted notes and the nut 5. The present invention is adapted to stop this sympathetic vibration as outlined in the preliminary statement of and objects of the invention. Accordingly, I have provided a damper which comprises, in its simplest embodiment, a channel member 9, having felt blocks 10 positioned within said channel member, and extending outwardly thereof, the said felt blocks overlying and engaging the strings 6 between the first fret and the nut 5. As the strings vary in diameter and in intensity of vibration, the damper is preferably diagonal thereto. To mount the damper, I have provided a post 11 secured at one end to a plate 12, the plate adapted to be fastened by screws or other means, to the head 3 with the post interposed between two of the strings, as best shown in Figure 2. The post is diametrically grooved at 13 and axially provided with a bore 14. Grooving the post at 13 provides two furcations 15 and 16 between which and within the groove 13 is positioned an annulus 17. Both furcations are diametrically bored and a shaft 18 is passed through the central bore of the annulus 17 and through the bores in said furcations. The annulus 17 is provided with a diametric bore 19 and the said shaft 18 is likewise diametrically bored at 20, with the bores 19 and 20 adapted to be in alignment, whereby an arm 21 may be passed therethrough, as shown in Figure 3. The annulus 17 is provided with a threaded bore 22 and the shaft 18 is bored at 23 whereby a set screw 24 within the threaded bore 22 may have its tip passed through bore 23 for engagement with arm 21 to lock the arm to the shaft and annulus. The said set screw performs the function of locking the annulus to the shaft so that rotation of the shaft will rotate the annulus and, in turn, raise or lower the arm 21. The annulus is provided with a peripheral notched portion 25 and the bore 14 accommodates a coil spring 26 which urges a ball detent 27 outwardly of the bore for engagement with the notch 25. The outer end of the arm 21 carries the felt blocks 10, as shown in Figure 1, the said arm being passed through the channel member 9 and between the felt blocks 10, see Figures 4 and 5. It is essential that the damper have rock-

3

able engagement with the arm 21 and to accomplish this, the arm is segmentally grooved at 28, with a screw 29 passed through the channel member 9, with its shank within the segmental groove 28. This holds the channel member 9 on the arm 21 in a defined position and likewise permits it to rock on the arm for the purpose of having the felt blocks at all times overlying and engaging the strings evenly. The shaft 13 carries a handle 30, positioned at right angles to the axis of the shaft, and which is adjacent a side of the head 3, as illustrated in Figures 1 and 2.

The operation, uses and advantages of the invention just described are as follows:

When the handle is in the position shown in Figure 1, the felt blocks overlie and engage the strings without depressing the same, between the first fret and the nut 5, and is maintained in this position by the ball detent being received within the recess 25. The damper is in position to diagonally span the strings 6. As before mentioned, certain of the strings have greater vibratory characteristics or the characteristics are more persistent and harder to damp with the result that the angle assumed by the damper will effectively perform its damping operation and prevent sympathetic vibration of those strings included between the nut and the fretted note. The player may easily lift the damper from the strings by striking the lever 30 which will raise the damper to the dotted line position of Figure 1, thus enabling the player to sound the open strings. The construction is such that the damping device considered as an entirety does not interfere with the fingering of the strings by the player as there is sufficient room between the damper and the first fret for the player's fingers, as illustrated in Figure 2. When it is desired to use the damping device, a slight movement of the handle 30 will rock the arm 21 downwardly so that the ball detent will be received within the notch 25 to again position the damper across the strings and in engagement therewith. The device is simple of construction and effective in actual use.

I claim:

1. A damping device for a guitar having a peg head for securing and tuning the strings including a member provided with damping material for overlying and engaging the strings of the guitar, a post secured to the peg head of said guitar, an arm extending between the post and the damping device, and means for rocking the arm to raise or lower the damping device onto the strings without depressing them.

2. A guitar damper including a member provided with damping material for engagement with the strings of the guitar, a post, an annulus carried by said post, an arm extending between the damping device and said annulus, a detent

4

between the post and the annulus and means for revolving the annulus to raise and lower the arm carrying the damping device.

3. A guitar damper including a post adapted to be secured to the head of the guitar, a damping member to be positioned over the strings of the guitar between the first fret and the nut, an arm extending between the damping device and said post and means carried by said post for revolving the arm to raise or lower the damping device.

4. A damper for fretted stringed instruments comprising a post adapted to be secured to the head of said stringed instrument, said post provided with a bifurcated portion, an annulus within said bifurcated portion, a shaft passed through the center of said annulus and through said bifurcated portion of the post, a channel member, damping blocks within said channel member, and an arm extending through said channel member and likewise through the annulus and said shaft.

5. A damper for fretted stringed instruments comprising a post adapted to be secured to the head of said stringed instrument, said post provided with a bifurcated portion, an annulus within said bifurcated portion, a shaft passed through the center of said annulus and through said bifurcated portion of the post, a channel member, damping blocks within said channel member, an arm extending through said channel member and likewise through the annulus and said shaft, and a detent engaging said annulus for holding said arm in a selected position.

6. A damping device for guitars including a damping member for overlying and diagonally engaging the strings of the guitar for evenly damping the strings to prevent sympathetic vibration of other strings, when certain of said strings are struck for playing the guitar, means for lowering said damping member into engagement with said strings, or for raising said damping member above said strings out of engagement therewith, and means for detachably holding said damping member lowered into damping engagement with said strings, while playing the guitar.

7. A damping device as claimed in claim 6, in which the damper diagonally engages the strings between the nut and the first fret of the guitar.

GEORGE VAN EPS.

#### REFERENCES CITED

The following references are of record in the file of this patent:

#### UNITED STATES PATENTS

Number	Name	Date
1,215,973	Olmedo	Feb. 13, 1917
1,579,893	Simpson	Apr. 6, 1926
1,826,969	Truett et al.	Oct. 31, 1931