



- (51) International Patent Classification:
H02G 15/06 (2006.01) *H02G 15/064* (2006.01)
- (21) International Application Number:
PCT/EP2011/002504
- (22) International Filing Date:
19 May 2011 (19.05.2011)
- (25) Filing Language: English
- (26) Publication Language: English
- (71) Applicant (for all designated States except US): **PRYSMIAN S.p.A.** [IT/IT]; Viale Sarca 222, I-20126 Milano (IT).
- (72) Inventor; and
- (75) Inventor/Applicant (for US only): **QUAGGIA, Dario** [IT/IT]; c/o Prysmian Cavi e Sistemi Energia S.r.l., Viale Sarca 222, I-20126 Milano (IT).
- (74) Agents: **BOTTERO, Claudio** et al.; PORTA, CHECCACCI & ASSOCIATI S.p.A., Via Trebbia 20, I-20135 Milano (IT).

- (81) Designated States (unless otherwise indicated, for every kind of national protection available): AE, AG, AL, AM, AO, AT, AU, AZ, BA, BB, BG, BH, BR, BW, BY, BZ, CA, CH, CL, CN, CO, CR, CU, CZ, DE, DK, DM, DO, DZ, EC, EE, EG, ES, FI, GB, GD, GE, GH, GM, GT, HN, HR, HU, ID, IL, IN, IS, JP, KE, KG, KM, KN, KP, KR, KZ, LA, LC, LK, LR, LS, LT, LU, LY, MA, MD, ME, MG, MK, MN, MW, MX, MY, MZ, NA, NG, NI, NO, NZ, OM, PE, PG, PH, PL, PT, RO, RS, RU, SC, SD, SE, SG, SK, SL, SM, ST, SV, SY, TH, TJ, TM, TN, TR, TT, TZ, UA, UG, US, UZ, VC, VN, ZA, ZM, ZW.
- (84) Designated States (unless otherwise indicated, for every kind of regional protection available): ARIPO (BW, GH, GM, KE, LR, LS, MW, MZ, NA, SD, SL, SZ, TZ, UG, ZM, ZW), Eurasian (AM, AZ, BY, KG, KZ, MD, RU, TJ, TM), European (AL, AT, BE, BG, CH, CY, CZ, DE, DK, EE, ES, FI, FR, GB, GR, HR, HU, IE, IS, IT, LT, LU, LV, MC, MK, MT, NL, NO, PL, PT, RO, RS, SE, SI, SK, SM, TR), OAPI (BF, BJ, CF, CG, CI, CM, GA, GN, GQ, GW, ML, MR, NE, SN, TD, TG).

[Continued on next page]

(54) Title: TERMINATION FOR ELECTRICAL CABLES AND METHOD FOR MANUFACTURING SUCH A TERMINATION

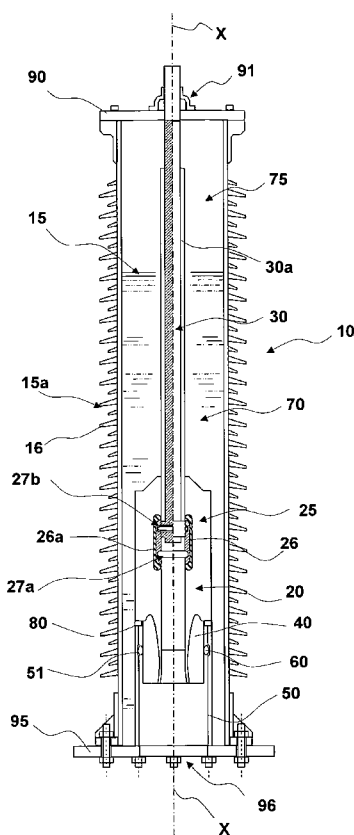

Fig. 1

(57) Abstract: Termination for electrical cables is disclosed comprising an outer insulation tubular body; a conductive rod coaxially arranged within said insulation tubular body; an elastomeric sleeve coaxially arranged within said insulation tubular body and extending about an end portion of said conductive rod; a connecting device coaxially arranged within said elastomeric sleeve, mechanically and electrically connected to said conductive rod and being adapted to be mechanically and electrically connected to an electrical cable; a conductive tubular element coaxially arranged within said insulation tubular body and adapted to be electrically connected to the ground; a semi-conductive element coaxially arranged within said conductive tubular element and partially extending inside said elastomeric sleeve on the opposite side to said conductive rod; at least one elastic conductive element radially interposed between and in a contact with said conductive tubular element and said semi-conductive element. Also disclosed is a method for manufacturing a termination for electrical cables and a method for connecting an electrical cable to a termination for electrical cables.

WO 2012/155934 A1

Published:

— *with international search report (Art. 21(3))*

**Termination for electrical cables and method for
manufacturing such a termination**

* * * * *

DESCRIPTION

5 The present invention relates to a termination for electrical cables, in particular for medium or high or very high voltage electrical cables.

The invention also relates to a method for manufacturing the aforementioned termination.

10 Throughout the present description and the attached claims, the term "termination" is used to indicate a jointing assembly specifically provided for mechanically and electrically connecting an electrical cable to a bare conductor, for example an overhead conductor, which is, in
15 turn connected to a different device, such as for example an electrical power source, a transformer, a user device etc.

In the present description, the term "medium voltage" is used to refer to a tension typically from about 1 kV to
20 about 30 kV, while the term "high voltage" refers to a tension above 30 kV. The term "very high voltage" is used to define a tension greater than about 150 kV or 220 kV, up to 500 kV or more.

Medium or high or very high voltage electrical cables
25 typically comprise one or more conductors covered by an insulating layer. A conductive screen is coaxially applied at a radially outer position with respect to the insulating layer of the conductors. A semi-conductive layer is radially interposed between the insulating layer
30 of the conductors and the conductive screen. A protective sheath is coaxially applied at a radially outer position with respect to the conductive screen.

- 2 -

Terminations for medium or high or very high voltage electrical cables typically comprise a sleeve made of elastomeric material and a conductive rod adapted to be connected to the bare conductor. A connector is provided
5 inside the sleeve to mechanically and electrically connect the conductive rod to the electrical cable, so as to provide the electrical connection between the electrical cable and the bare conductor. The sleeve further comprises a semi-conductive cylindrical insert for controlling the electrical
10 field within sleeve, in particular to avoid the presence of areas with high concentration of electrical field wherein undesired electrical discharges and breakdowns could occur. A conductive element is arranged in a radially outer position with respect to the semi-conductive cylindrical insert in a
15 contact relationship therewith.

When connecting the electrical cable to the termination, the electrical cable is treated in such a manner that the conductors axially project by a predetermined amount with respect to the radially outer layers. Such conductors are
20 then electrically and mechanically connected to the connector of the termination to provide the desired electrical continuity between the electrical cable and the conductive rod of the termination.

Upon connection of the electrical cable to the termination,
25 the semi-conductive layer of the electrical cable should be arranged in a steady contact relationship with the semi-conductive insert of the termination in order to provide the electrical cable with an appropriate ground connection through the conductive element of the termination.

30 US 5,316,492 discloses a plug-in connection for a high voltage plastic cable in a high voltage outside termination. The plug-in connection comprises an elastic sleeve insulator with stress-controlling electrically conducting body, an insulating body surrounding the sleeve insulator and an

electrically conducting sheath surrounding the insulating body. The sleeve insulator is assembled in a mechanically strong and leak-tight manner on a metal foot plate in a ground plate of the outside termination.

5 The Applicant observed that the electrically conducting body and the electrically conducting sheath of a termination of the above-described type, being both made of a rigid material, cannot be radially expanded to allow the termination to be connected to electrical cables having a
10 diameter greater than the one prefixed in the design stage.

The Applicant also observed that, should the above termination be connected with electrical cables having a diameter lower than the one prefixed in the design stage, the desired steady contact between the electrically conducting
15 sheath of the termination and the semi-conductive layer of the electrical cable could not be achieved.

Indeed, the Applicant noticed that for the above reasons each of the terminations of the prior art can be used only with electrical cables of a specific size, that is
20 electrical cables having different diameters require using terminations of different size to provide the electrical cables with an appropriate ground connection.

In addition thereof, the Applicant observed that, still due to the fact that the semi-conductive element of the
25 terminations of the prior art are made of a rigid material, these terminations does not allow radial expansions of the electrical cable due to possible thermal variations occurring during the operative lifecycle thereof.

Furthermore, the Applicant observed that in the termination
30 of US 5,316,492 a stuffing box is provided at a radially outer position with respect to the conducting sheath to provide the desired axial tightness within the termination.

- 4 -

However, the Applicant noticed that such an axial tightness might be compromised should radial expansions of the electrically conducting body and the conducting sheath occur due, for example, to the fact that the termination is
5 connected with electrical cables having a diameter higher than the one prefixed in the design stage or due to thermal variations occurring during the operative lifecycle of the electrical cable connected to the termination.

The Applicant faced the technical problem of providing a
10 termination which is capable of being connected to electrical cables having different diameters and which allows radial expansions of the electrical cables due to thermal variations occurring during the operative lifecycle thereof, while providing at the same time the electrical cable with the
15 appropriate ground connection by maintaining a steady contact between the semi-conductive element of the termination and the semi-conductive layer of the electrical cables.

The Applicant also faced the technical problem of providing a termination which is capable of ensuring the
20 desired tightness both in case of different cable diameters and in presence of thermal expansions.

As disclosed in more detail below, the Applicant found that the problems above can be solved by arranging an elastic conductive element between the conductive element of the
25 termination and the semi-conductive element of the termination, said at least one elastic conductive element exerting an elastic force onto the semi-conductive element of the termination along at least one radial direction towards the longitudinal axis of the termination.

30 In particular, the Applicant found that the desired steady contact between the semi-conductive element of the electrical cable connected to the termination and the semi-conductive element of the termination can be ensured, irrespective of the specific diameter of the electrical

- 5 -

cable and irrespective of any possible thermal variation occurring during the operative lifecycle of the electrical cable, by exerting on the semi-conductive element of the termination an elastic force along at least one radial
5 direction towards the longitudinal axis of the termination. The semi-conductive element of the termination can thus be radially displaced towards and away from the longitudinal axis of the termination, depending on the actual diameter of the electrical cable connected thereto, while remaining
10 in a steady electrical contact relationship with the conductive element of the termination.

Accordingly, in a first aspect thereof, the present invention relates to a termination for electrical cables, comprising:

- 15 - an outer insulation tubular body having a longitudinal axis;
- a conductive rod coaxially arranged within said insulation tubular body;
- an elastomeric sleeve coaxially arranged within said
20 insulation tubular body and extending about an end portion of said conductive rod;
- a connecting device coaxially arranged within said elastomeric sleeve, said connecting device being mechanically and electrically connected to said conductive
25 rod and being adapted to be mechanically and electrically connected to an electrical cable;
- a conductive tubular element coaxially arranged within said insulation tubular body and adapted to be electrically connected to the ground;
- 30 - a semi-conductive element coaxially arranged within said conductive tubular element and partially extending inside said elastomeric sleeve on the opposite side to said conductive rod with respect to said connecting device;
- at least one elastic conductive element radially
35 interposed between, and in a contact with, said conductive tubular element and said semi-conductive element, said at

least one elastic conductive element exerting an elastic force onto said semi-conductive element along at least one radial direction towards said longitudinal axis.

In a second aspect thereof, the present invention relates to a method for manufacturing a termination for electrical cables, comprising:

- providing an elastomeric sleeve having a longitudinal axis and including, in a radially inner position thereof, a connecting device;
- 10 - coaxially arranging a semi-conductive element with respect to said elastomeric sleeve so that a first portion of said semi-conductive element axially extends inside said elastomeric sleeve and a second portion of said semi-conductive element axially extends outside said elastomeric sleeve;
- 15 - inserting an end portion of a conductive rod into said elastomeric sleeve on the opposite side with respect to said to said semi-conductive element to electrically and mechanically connect said conductive rod to said connecting device;
- 20 - arranging at least one elastic conductive element in a radially inner position with respect to a conductive tubular element;
- fitting said conductive tubular element onto said second portion of said semi-conductive element so that said at least one elastic conductive element is radially interposed between, and in a contact with, said conductive tubular element and said semi-conductive element and exerts an elastic force onto said semi-conductive element along at least one radial direction towards said longitudinal axis;
- 30 - coaxially arranging an outer insulation tubular body in a radially outer position with respect to said conductive bar, said elastomeric sleeve and said conductive tubular element.

35 Throughout the present description and in the following

claims, the terms "radial" and "axial" (or "longitudinal") are used to indicate a perpendicular direction and a parallel direction, respectively, to a reference longitudinal axis of the termination, the above reference longitudinal axis being
5 defined by the longitudinal axis of any one among the outer insulation tubular body, the conductive rod, the elastomeric sleeve and the conductive tubular element of the termination. The expression "radially inner/outer" is instead used by referring to the position along a radial direction with
10 respect to the abovementioned longitudinal axis.

Throughout the present description and in the following claims, the terms "above" and "below" are used with reference to an upright position of the termination, that is when the aforementioned reference longitudinal axis is
15 oriented vertically.

In least one of the aforementioned aspects the invention can comprise at least one of the following preferred features, taken separately or in combination.

Preferably, the termination comprises a leak-tight element
20 axially interposed between said elastomeric sleeve and said conductive tubular element.

Advantageously, the Applicant observed that the provision of a leak-tight element which acts in the axial direction between the elastomeric sleeve and the conductive tubular
25 element allows to provide the termination with a sealing system which is not sensitive at all to possible radial expansion of the semi-conductive element of the termination due for example to thermal variations occurring during the operative lifecycle of the electrical cable connected to
30 the termination. The desired axial sealing effect and radial electrical connection are thus provided by two different systems which are structurally and functionally independent from each other.

- 8 -

In a preferred embodiment thereof, the termination comprises at least two elastic conductive elements arranged at different axial positions.

5 Preferably, said at least one elastic conductive element comprises at least one annular spring coaxially arranged within said conductive tubular element in a radially outer position with respect to said semi-conductive element.

10 More preferably, said annular spring comprises a metallic wire spirally wound along an annular path extending about said longitudinal axis to define a plurality of coils.

Still more preferably, each of said coils lays on a plane which does not include said longitudinal axis.

In a preferred embodiment, said insulation tubular body is at least partially filled at least with silicon gel.

15 Preferably, said connecting device comprises a first seat for a plug-in connection to said electrical cable and an axially opposite seat for a plug-in connection to said conductive rod.

20 Preferably, the method of manufacturing the termination of the present invention comprises axially interposing a leak-tight element between said elastomeric sleeve and said conductive tubular element.

25 Preferably, the method of manufacturing the termination of the present invention comprises at least partially filling said insulation tubular body at least with silicon gel.

Alternatively said insulation tubular body can be filled with another insulating fluid, like oil or similar materials.

30 Further features and advantages of the present invention will appear more clearly from the following detailed

description of some preferred embodiments thereof, such description being provided merely by way of non-limiting example and being made with reference to the annexed drawings. In such drawings:

- 5 - figure 1 is a schematic and partially sectioned view of a termination according to the present invention;
- figure 2 is a perspective view of a conductive elastic element used in the termination of figure 1;
- figure 3 is a schematic sectional view of a step of the
10 manufacturing process of the termination of figure 1;
- figure 4 is a schematic sectional view of a further step of the manufacturing process of the termination of figure 1;
- figure 5 is a schematic sectional view of a further step
15 of the manufacturing process of the termination of figure 1;
- figure 6 is a schematic sectional view of a further step of the manufacturing process of the termination of figure 1;
- 20 - figure 7 is a schematic sectional view of the termination of figure 1 in a factory testing configuration;
- figure 8 is a schematic view of a step of the field installation of the termination of figure 1;
- 25 - figure 9 is a schematic view of a further step of the field installation of the termination of figure 1.

With respect to figure 1, a termination for electrical cables according to the present invention is indicated with numeral reference 10.

- 30 In particular, the termination of figure 1 is used for medium or high voltage electrical cables, but it can be also used for very high voltage electrical cables.

As will be better explained in the following of this description, the termination 10 is a pre-fabricated

termination, i.e. it can be wholly assembled in a factory. Accordingly, the termination 10 can also be tested in the factory before shipping to the installation area for field installation. This allows reducing the operations to be
5 carried out at the installation area as well as the technical skills of the operators involved.

The termination 10 comprises an outer insulation tubular body 15 having a longitudinal axis X-X. This body comprises a portion 15a shaped so as to define a plurality of fins. Only
10 one of these fins is indicated with 16 in figure 1.

Preferably, the insulation tubular body is made of a composite material.

An elastomeric sleeve 20 is coaxially arranged within the insulation tubular body 15. A connecting device 25 is
15 coaxially arranged within the elastomeric sleeve 20.

Preferably, the elastomeric sleeve 20 comprises a pre-moulded silicone body.

A conductive rod 30 is coaxially arranged within the insulation tubular body 15. Conveniently, the conductive
20 rod 30 is coated by an insulating layer 30a. An end portion of the conductive rod 30 (and of the relevant insulating layer 30a) is coaxially arranged within the elastomeric sleeve 20.

The connecting device 25 is of the so-called "plug-in"
25 type. The connecting device comprises a socket body 26 having, on a first side thereof, a seat 27a adapted to house and lock into a desired axial position a plug 102 associated with the end of the conductor of an electrical cable 100 (figures 8 and 9) and, on the axially opposite
30 side, a seat 27b adapted to house and lock into a desired axial position a plug 31 (figure 3) associated with the end portion of the conductive rod 30. Preferably, the

- 11 -

socket body 26 is made of conductive material (e.g. aluminium, copper or the like), and is surrounded by a semi-conductive body 26a,

Each of the aforementioned plugs 102 and 31 in turn
5 comprises a seat adapted to receive the end portion of the electrical cable 100 and of the conductive rod 30, respectively, and to hold this end portion by means of clamping, crimping, screws or welding.

Upon being associated with the end portion of the
10 electrical cable 100 and of the conductive rod 30, respectively, the plugs 102, 31 are mechanically and electrically coupled together and to the connecting device 25 in a conventional manner (for example, as disclosed in US 5,316,492), thus providing mechanical and electrical
15 connection between the electrical cable 100 and the conductive rod 30.

A cylindrical semi-conductive element 40 is coaxially arranged within the insulation tubular body 15 to provide an electrical field control.

20 An end portion of the semi-conductive element 40 axially extends inside the elastomeric sleeve 20 while the remaining portion of the semi-conductive element 40 axially extends outside the elastomeric sleeve 20.

A conductive tubular element 50 is coaxially arranged
25 within the insulation tubular body 15 in a radially outer position with respect to the semi-conductive element 40.

An elastic conductive element 60 is radially arranged between the conductive tubular element 50 and the semi-conductive element 40 in a steady contact relationship
30 with both the elastic conductive element 60 and the conductive tubular element 50, thus providing an electrical and mechanical connection between the elastic

- 12 -

conductive element 60 and the semi-conductor element 40.

The elastic conductive element 60 exerts an elastic force onto the semi-conductive element 40 along a radial direction towards the longitudinal axis X-X so as to push the semi-
5 conductive element 40 against a semi-conductive layer 101 of the electrical cable 100, thus realizing a steady contact relationship between the semi-conductive element 40 of the termination 10 and the semi-conductive layer 101 of the electrical cable 100, irrespective of the actual
10 diameter of the electrical cable 100. The desired ground connection of the electrical cable 100 is thus achieved.

Preferably, more than one elastic conductive element 60 is provided. In a preferred embodiment of the invention, two elastic conductive elements 60 are arranged at different
15 axial positions between the conductive tubular element 50 and the semi-conductive element 40.

In order to provide a steady positioning of the elastic conductive element 60 with respect to the conductive tubular element 50, an appropriate seat 51 is provided in
20 the radially inner surface of the conductive tubular element 50 to house the radially outer surface of the elastic conductive element 60, as better shown in figure 4.

Referring now to figure 2, the elastic conductive element 60 is preferably an annular spring 61 made of a metallic
25 wire 62 spirally wound along an annular path so as to define a plurality of coils. Only one of these coils is indicated with 63 in figure 2.

Each of the coils 63 lays on a plane which does not extend radially, that is this plane does not include the
30 longitudinal axis X-X. This allows an elastic force to be provided in the radial direction towards the longitudinal axis X-X when the spring 61 is arranged, in a radially stressed condition, between the conductive tubular element 50

- 13 -

and the semi-conductive element 40 of the termination 10. The desired steady contact relationship between the semi-conductive element 40 and the semi-conductive layer 101 of the electrical cable 100 is thus obtained irrespective of the actual diameter of the electrical cable 100.

For example, when it is used an annular spring 61 having an outer diameter of 200 mm and an inner diameter of 170 mm, the diameter of the electrical cable 100 can be in the range from 85 mm to 95 mm

10 The insulation tubular body 15 is filled with a filling compound 70. Preferably, this filling compound 70 comprises silicon gel 71 and PE pellets 72 (figure 6). The amount of filling compound 70 to be filled within the insulation tubular body 15 is selected so that when the termination 10
15 is in an upright position as that shown in figure 1, the filling compound 70 reaches a predetermined height. In this configuration, a portion 75 of the cavity defined between the insulation tubular body 15 and the conductive rod 30 is not filled with the filling material 70.

20 The silicon gel 71 is filled into the insulation tubular body 15 in a liquid state. After polymerisation, it reaches a soft solid-state so that it is prevented to flow out the insulation tubular body 15.

In an alternative embodiment, the insulation tubular body
25 15 is filled with oil or other appropriate insulating fluid.

As shown in figure 1, a leak-tight element 80 (for example, an annular gasket) is coaxially arranged within the insulation tubular element 15. The leak-tight element 80 is axially interposed between the elastomeric sleeve 20 and
30 the conductive tubular element 50, so as to avoid the filling material 70 to flow within the conductive tubular element 50, thus providing the desired axial tightness within the termination.

- 14 -

In addition thereof, the leak-tight element 80 acts as an intermediate pad between the elastomeric sleeve 20 and the conductive tubular element 50, thus preventing any friction or rubbing between the elastomeric sleeve 20 and the
5 conductive tubular element 50 and allowing the weight of the elastomeric sleeve 20 and of the terminal's component connected to the elastomeric sleeve 20 not to directly bear onto the conductive tubular element 50, preventing a possible indentation of the elastomeric sleeve 20.

10 Preferably, the leak-tight element 80 is made of a rubber-like material.

Preferably, the leak-tight element 80 has an annular shape with a substantially rectangular cross-section.

The leak-tight element 80 has a thickness of some
15 millimeters, preferably from about 5 to about 15 mm.

The tightness between the elastomeric sleeve 20 and the conductive tubular elements 50 is provided in the axial direction. This ensures that the seal is not affected, or at least affected in a minor amount, by the expansion or
20 contraction of the elastomeric sleeve, which acts mainly in the radial direction.

A cover plate 90 is provided at a free end of the insulation tubular body 15. The cover plate 90 comprises a central hole 91 for allowing insertion of the conductive
25 rod 30 into the insulation tubular body 15.

A flange 95 is provided at the free end of the insulation tubular body 15 opposite the cover plate 90. The flange 95 comprises a central hole 96 for allowing insertion of the electrical cable 100.

30 Preferably, the flange 95 is made in a single piece with the conductive tubular element 50, welded or otherwise secured thereto.

- 15 -

With reference to figures 3 to 6, a method for manufacturing the termination 10 of the present invention is described below. This method can be entirely carried out within the factory.

5 Firstly, an elastomeric sleeve 20 including the connecting device 25 and the first axial portion of the semi-conductive element 40 is provided. As shown in figure 3, the remaining axial portion of the semi-conductive element 40 extends outside the semi-conductive element 40.

10 The elastomeric sleeve 20 is supported in an upright position and the conductive rod 30 is inserted from the above and locked into the seat 27b of the connecting device 25 (figure 3).

On the other hand, the elastic conductive element 60 is
15 housed in the seat 51 of the conductive tubular element 50 and the leak-tight element 80 is arranged at the upper end portion of the conductive tubular element 50.

The conductive tubular element 50 is then fitted onto the
20 second portion of the semi-conductive element 40 from below so as to reach the configuration shown in figure 4, wherein the elastomeric sleeve 20 rests onto the leak-tight element 80 and the elastic conductive element 60 is interposed, in a radially stressed condition, between the semi-conductive element 40 and the conductive tubular element 50.

25 The insulation tubular body 15 is then fitted from the above onto the conductive rod 30, as shown in figure 5, and is connected to the flange 95 as shown in figure 6.

A filling compound 70 is then filled into the insulation
30 tubular body 15 up to reach a predetermined height. As shown in figure 6, filling of the filling compound 70 comprises filling the silicon gel 71 into the insulation tubular body 15 from below and introducing the PE pellets

- 16 -

into the insulation tubular body 15 from the above.

The cover plate 90 is then associated to the upper end of the insulation terminal body 15, thus obtaining the termination 10 shown in figure 1.

- 5 The termination 10 manufactured according to the method described above is tested in the factory before shipping to the installation area.

As shown in figure 7, in order to properly test the termination 10 a test vessel 150 filled with oil 151 and
10 having a test cable 160 partially inserted therein and kept in vertical position is used.

The termination 10 is fitted from the above onto the portion of the test cable 160 extending above the test vessel 150. The upper end portion of the test cable 160 is
15 locked to the connecting device 25 of the termination 10 and the termination 10 is clamped to the test vessel 150 by appropriate clamping devices 170.

The required electrical routine tests can then be carried out.

- 20 Upon being tested, the termination 10 can be shipped to the installation area for carrying out the field installation.

As shown in figures 8 and 9, the installation operation comprises the provision of a framework 200 at the
25 installation area.

The electrical cable 100 is then prepared in such a manner that the conductors axially project by a predetermined amount with respect to all the radially outer layers and that semi-conductive layer 101 axially projects by a
30 predetermined amount portion with respect to the respective radially outer layers.

- 17 -

The plug 102 is then associated to the conductors of the electrical cable 100 and the electrical cable 100 is associated with the framework 200 and kept in vertical position, as shown in figure 8.

5 The termination 10 is then fitted from the above onto the portion of the electrical cable 100 extending above the framework 200. The plug 102 is locked to the connecting device 25 of the termination 10 and the termination 10 is clamped to the framework 200 by appropriate clamping
10 devices, so as to reach the operative configuration shown in figure 9.

From the above it is clear that the elastic conductive element 60 provides for a controlled radial expansion/contraction of the semi-conductive element 40 to
15 be allowed while at the same time maintaining a steady contact relationship between the semi-conductive element 40 of the termination and the semi-conductive layer 101 of the electrical cable 100, thus providing the electrical cable 100 with the desired ground connection irrespective
20 of the actual diameter of the electrical cable 100.

The elastic conductive element 60 further elastically supports the semi-conductive element 40 and the elastomeric sleeve 20 when the termination 10 is arranged in a horizontal position and shipped from the factory to
25 the installation area.

The elastic conductive element 60 further facilitates the assembling operation of the termination 10 in the factory by properly supporting in the desired coaxial position the elastomeric sleeve 20 with respect to the conductive
30 tubular element 50 through the semi-conductive element 40.

The elastic conductive element 60 further contributes to segregate the filling material 70 within the insulation tubular body 15 should undesired leakage of the filling

material 70 occur.

In addition thereof, by providing an increased radial pressure against the electrical cable 100, the elastic conductive element 60 further contributes to increase the electrical capacity of the termination 10 to withstand to electrical discharges and breakdowns. Indeed, the higher is the above radial pressure the higher is the above electrical capacity.

Furthermore, the elastic conductive element 60 provides for an explosion-proof barrier. Indeed, the elastic conductive element 60 is preferably sized so as to be able to withstand to the breakdown currents which could be generated should a breakdown occur in operation.

In addition thereof, the elastic conductive element 60 allows discharging to the ground, through the conductive tubular element 50, the capacitive current collected by the semi-conductive element 40 when it is put in contact with the semi-conductive layer 101 of the electrical cable 100.

CLAIMS

1. Termination (10) for electrical cables, comprising:
- an outer insulation tubular body (15) having a longitudinal axis (X-X);
 - 5 - a conductive rod (30) coaxially arranged within said insulation tubular body (15);
 - an elastomeric sleeve (20) coaxially arranged within said insulation tubular body (15) and extending about an end portion of said conductive rod (30);
 - 10 - a connecting device (25) coaxially arranged within said elastomeric sleeve (20), said connecting device (25) being mechanically and electrically connected to said conductive rod (30) and being adapted to be mechanically and electrically connected to an electrical cable (100);
 - 15 - a conductive tubular element (50) coaxially arranged within said insulation tubular body (15) and adapted to be electrically connected to the ground;
 - a semi-conductive element (40) coaxially arranged within said conductive tubular element (15) and partially
 - 20 extending inside said elastomeric sleeve (20) on the opposite side to said conductive rod (30) with respect to said connecting device (25);
 - at least one elastic conductive element (60) radially interposed between, and in a contact with, said conductive
 - 25 tubular element (50) and said semi-conductive element (40), said at least one elastic conductive element (60) exerting an elastic force onto said semi-conductive element (40) along at least one radial direction towards said longitudinal axis (X-X).
- 30 2. Termination (10) according to claim 1, comprising a leak-tight element (80) axially interposed between said elastomeric sleeve (20) and said conductive tubular element (50).
3. Termination (10) according to claim 1 or 2, comprising

- 20 -

at least two elastic conductive elements (60) arranged at different axial positions.

4. Termination (10) according to any of the previous claims, wherein said at least one elastic conductive
5 element (60) comprises at least one annular spring (61) coaxially arranged within said conductive tubular element (50) in a radially outer position with respect to said semi-conductive element (40).

5. Termination (10) according to claim 4, wherein said
10 annular spring (61) comprises a metallic wire (62) spirally wound along an annular path extending about said longitudinal axis (X-X) to define a plurality of coils (63).

6. Termination (10) according to claim 5, wherein each of
15 said coils (63) lays on a plane which does not include said longitudinal axis (X-X).

7. Termination (10) according to any of the previous claims, wherein said insulation tubular body (15) is at least partially filled at least with silicon gel (71).

8. Termination (10) according to any of the previous claims,
20 wherein said connecting device (25) comprises a first seat (27a) for a plug-in connection to said electrical cable (100) and an axially opposite seat (27b) for a plug-in connection to said conductive rod (30).

9. Method for manufacturing a termination (10) for
25 electrical cables, comprising:

- providing an elastomeric sleeve (20) having a longitudinal axis (X-X) and including, in a radially inner position thereof, a connecting device (25);
- coaxially arranging a semi-conductive element (40) with
30 respect to said elastomeric sleeve (20) so that a first portion of said semi-conductive element (40) axially extends inside said elastomeric sleeve (20) and a second

- 21 -

portion of said semi-conductive element (40) axially extends outside said elastomeric sleeve (20);

- inserting an end portion of a conductive rod (30) into said elastomeric sleeve (20) on the opposite side with respect to said to said semi-conductive element (40) to electrically and mechanically connect said conductive rod (30) to said connecting device (25);

- arranging at least one elastic conductive element (60) in a radially inner position of a conductive tubular element (50);

- fitting said conductive tubular element (50) onto said second portion of said semi-conductive element (40) so that said at least one elastic conductive element (60) is radially interposed between, and in a contact with, said conductive tubular element (50) and said semi-conductive element (40) and exerts an elastic force onto said semi-conductive element (40) along at least one radial direction towards said longitudinal axis (X-X);

- coaxially arranging an outer insulation tubular body (15) in a radially outer position with respect to said conductive rod (30), said elastomeric sleeve (20) and said conductive tubular element (50).

10. Method according to claim 9, comprising axially interposing a leak-tight element (80) between said elastomeric sleeve (20) and said conductive tubular element (50).

11. Method according to claim 9 or 10, comprising at least partially filling said insulation tubular body (15) at least with silicon gel (71).

12. Method for connecting an electrical cable (100) to a termination (10) for electrical cables, comprising:

- providing a termination (10) according to any of claims 1 to 8;

- mechanically and electrically connecting said electrical

- 22 -

cable (100) to said connecting device (25).

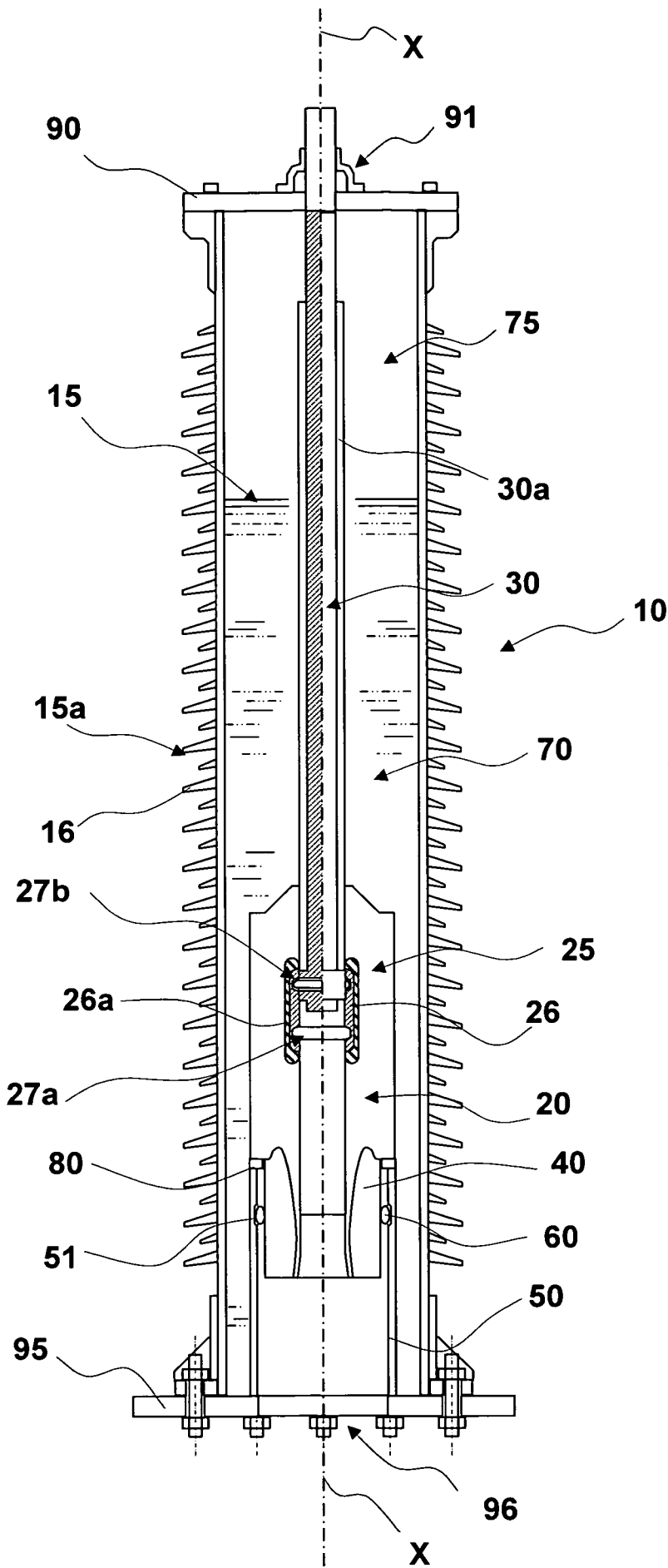

Fig. 1

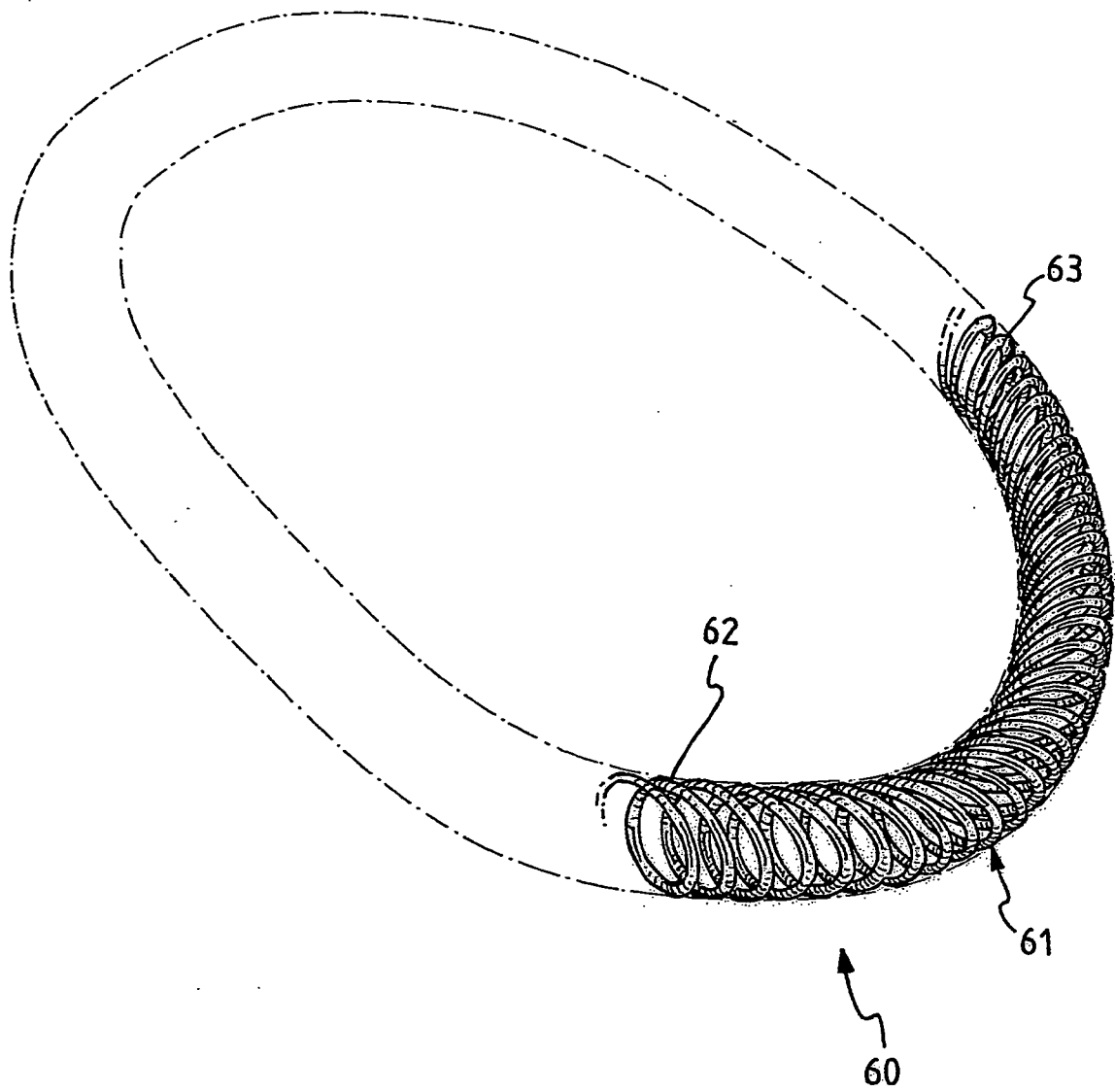

Fig. 2

3/9

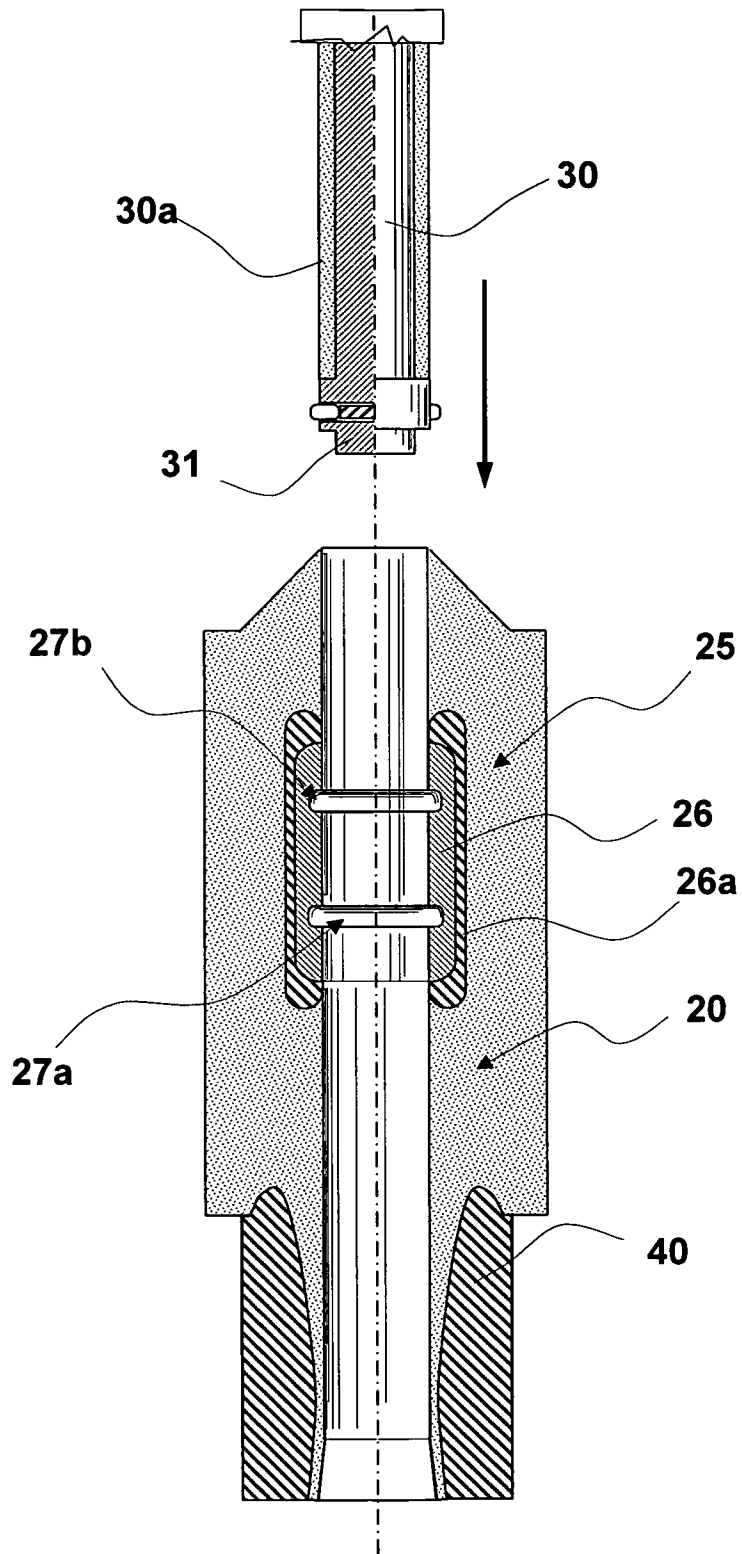

Fig. 3

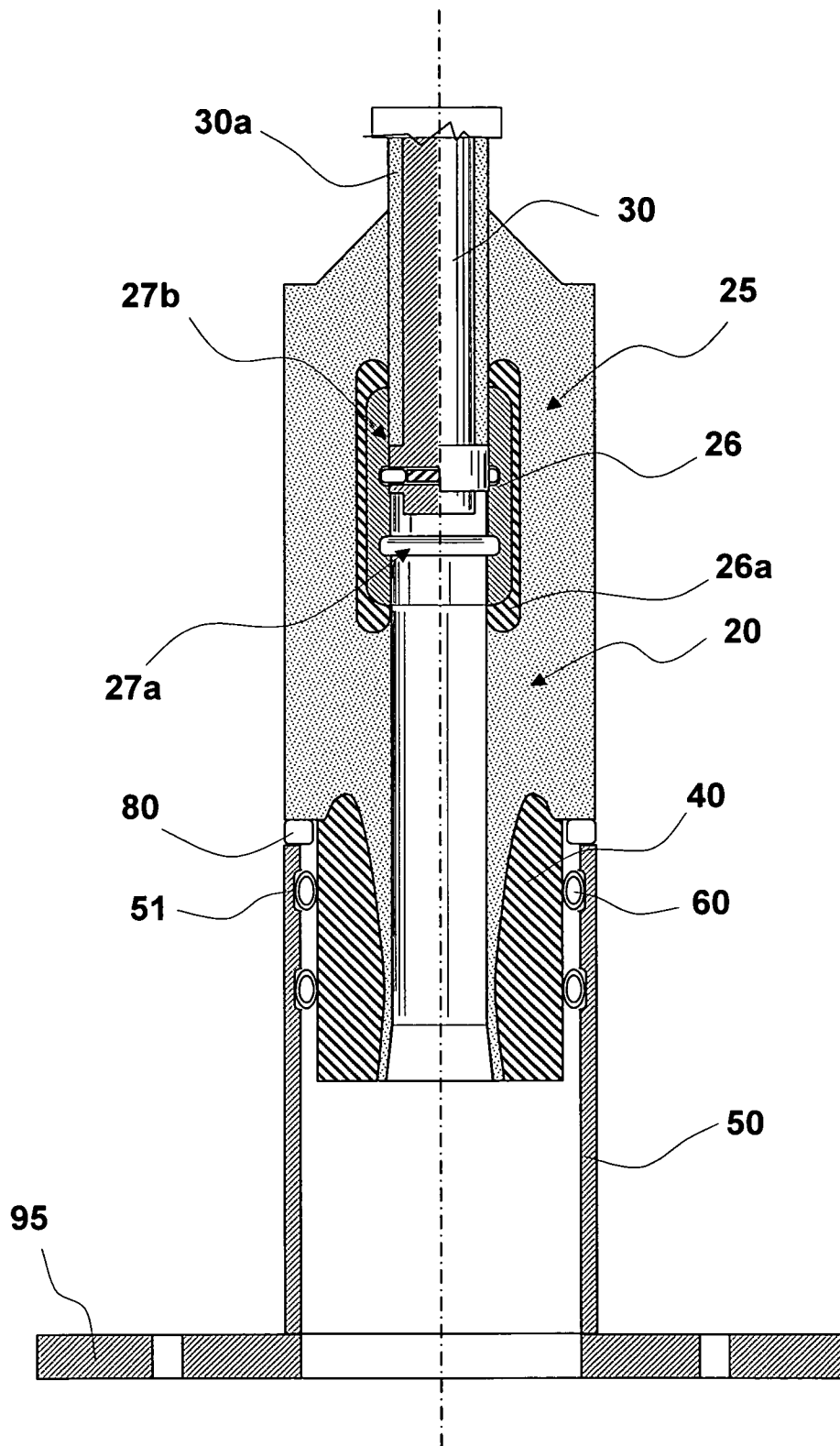

Fig. 4

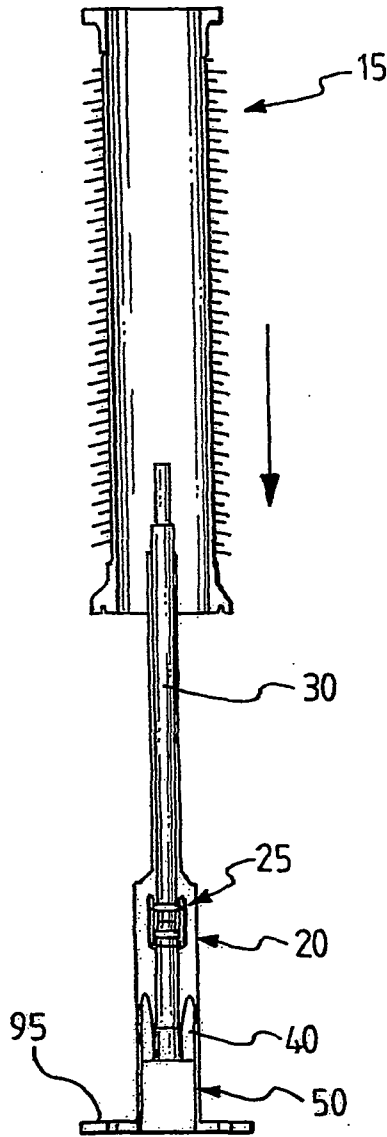

Fig.5

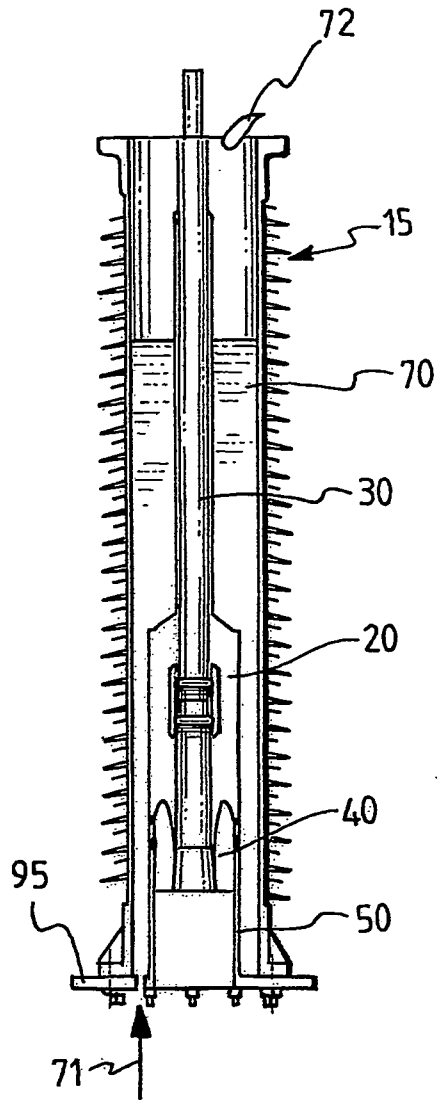

Fig. 6

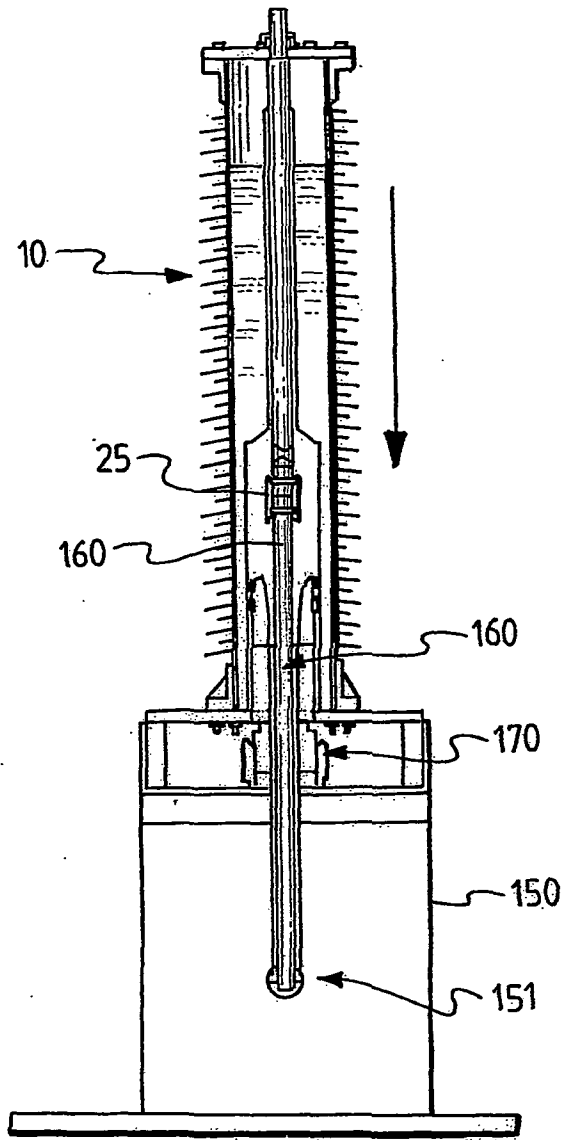

Fig. 7

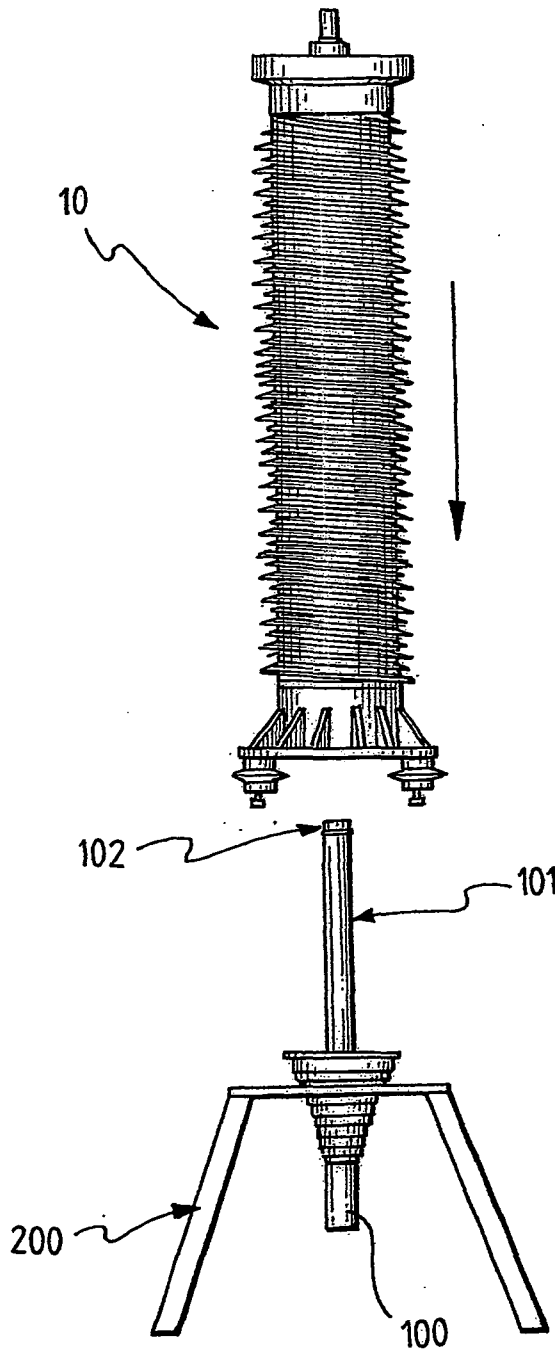

Fig. 8

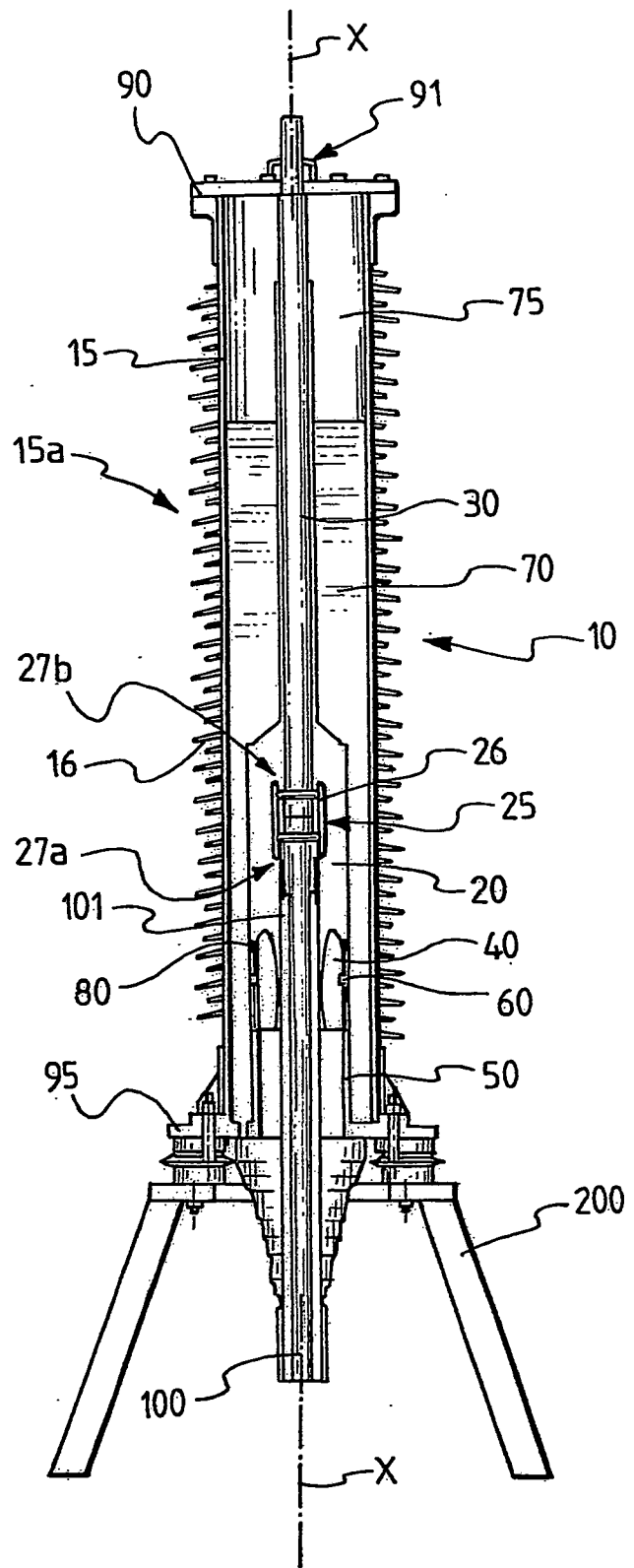

Fig.9

INTERNATIONAL SEARCH REPORT

International application No

PCT/EP2011/002504

A. CLASSIFICATION OF SUBJECT MATTER
 INV. H02G15/06 H02G15/064
 ADD.

According to International Patent Classification (IPC) or to both national classification and IPC

B. FIELDS SEARCHED

Minimum documentation searched (classification system followed by classification symbols)
 H02G H01R H01B

Documentation searched other than minimum documentation to the extent that such documents are included in the fields searched

Electronic data base consulted during the international search (name of data base and, where practical, search terms used)

EPO-Internal, WPI Data

C. DOCUMENTS CONSIDERED TO BE RELEVANT

Category*	Citation of document, with indication, where appropriate, of the relevant passages	Relevant to claim No.
A	US 5 316 492 A (SCHAAREMAN JACOBUS M [NL]) 31 May 1994 (1994-05-31) cited in the application column 5, line 50 - column 8, line 30; figure 7	1-12
A	----- WO 2006/015735 A1 (SUEDKABEL GMBH [DE]) 16 February 2006 (2006-02-16) the whole document	1-12
A	----- JP 2008 278601 A (EXSYM CORP) 13 November 2008 (2008-11-13) the whole document	1-12
A	----- EP 2 194 627 A1 (SWCC SHOWA CABLE SYS CO LTD [JP]) 9 June 2010 (2010-06-09) paragraphs [0026] - [0056]; figures 1-3	1-12
	----- -/--	



Further documents are listed in the continuation of Box C.



See patent family annex.

* Special categories of cited documents :

"A" document defining the general state of the art which is not considered to be of particular relevance
 "E" earlier document but published on or after the international filing date
 "L" document which may throw doubts on priority claim(s) or which is cited to establish the publication date of another citation or other special reason (as specified)
 "O" document referring to an oral disclosure, use, exhibition or other means
 "P" document published prior to the international filing date but later than the priority date claimed

"T" later document published after the international filing date or priority date and not in conflict with the application but cited to understand the principle or theory underlying the invention
 "X" document of particular relevance; the claimed invention cannot be considered novel or cannot be considered to involve an inventive step when the document is taken alone
 "Y" document of particular relevance; the claimed invention cannot be considered to involve an inventive step when the document is combined with one or more other such documents, such combination being obvious to a person skilled in the art.
 "&" document member of the same patent family

Date of the actual completion of the international search

23 February 2012

Date of mailing of the international search report

02/03/2012

Name and mailing address of the ISA/

European Patent Office, P.B. 5818 Patentlaan 2
 NL - 2280 HV Rijswijk
 Tel. (+31-70) 340-2040,
 Fax: (+31-70) 340-3016

Authorized officer

Hermann, Robert

INTERNATIONAL SEARCH REPORT

International application No
PCT/EP2011/002504

C(Continuation). DOCUMENTS CONSIDERED TO BE RELEVANT		
Category*	Citation of document, with indication, where appropriate, of the relevant passages	Relevant to claim No.
A	JP 2007 159271 A (VISCAS CORP; FURUKAWA ELECTRIC CO LTD; FUJIKURA LTD) 21 June 2007 (2007-06-21) abstract; figures 1-6 -----	1-12

INTERNATIONAL SEARCH REPORT

Information on patent family members

International application No

PCT/EP2011/002504

Patent document cited in search report	Publication date	Patent family member(s)	Publication date
US 5316492	A	31-05-1994	AT 92678 T 15-08-1993
		AU 645495 B2	20-01-1994
		BR 9007344 A	28-04-1992
		CA 2063582 A1	04-11-1990
		CS 9002180 A2	15-09-1991
		DD 294376 A5	26-09-1991
		DE 69002625 D1	09-09-1993
		DE 69002625 T2	05-01-1994
		DK 0471032 T3	03-01-1994
		EP 0471032 A1	19-02-1992
		ES 2042300 T3	01-12-1993
		HU 208197 B	30-08-1993
		IE 66723 B1	24-01-1996
		JP H04505246 A	10-09-1992
		NL 8901138 A	03-12-1990
		NO 914305 A	01-11-1991
		PL 164146 B1	30-06-1994
		PT 93948 A	29-11-1991
		TR 25622 A	01-07-1993
		US 5316492 A	31-05-1994
		WO 9013933 A1	15-11-1990
		ZA 9003333 A	27-02-1991

WO 2006015735	A1	16-02-2006	AT 376275 T 15-11-2007
		DE 102004046134 A1	16-03-2006
		EP 1774632 A1	18-04-2007
		JP 2008509641 A	27-03-2008
		JP 2011087461 A	28-04-2011
		KR 20070053169 A	23-05-2007
		WO 2006015735 A1	16-02-2006

JP 2008278601	A	13-11-2008	JP 4621707 B2 26-01-2011
		JP 2008278601 A	13-11-2008

EP 2194627	A1	09-06-2010	CN 101809836 A 18-08-2010
		EP 2194627 A1	09-06-2010
		JP 4685908 B2	18-05-2011
		JP 2009100646 A	07-05-2009
		KR 20100064372 A	14-06-2010
		TW 200929766 A	01-07-2009
		US 2011114358 A1	19-05-2011

JP 2007159271	A	21-06-2007	JP 4762700 B2 31-08-2011
		JP 2007159271 A	21-06-2007
